

LGM

MODEL L™ ROOFTOP UNITS

Ultra-High Efficiency | Lennox® CORE Controller | Environ™ Coil | **R-454B** | 60Hz



**COMMERCIAL
PRODUCT SPECIFICATIONS (EHB)**

3 to 6 Tons

Net Cooling Capacity - 35,000 to 69,000 Btuh
Gas Input Heat Capacity - 65,000 to 150,000 Btuh

MODEL / L

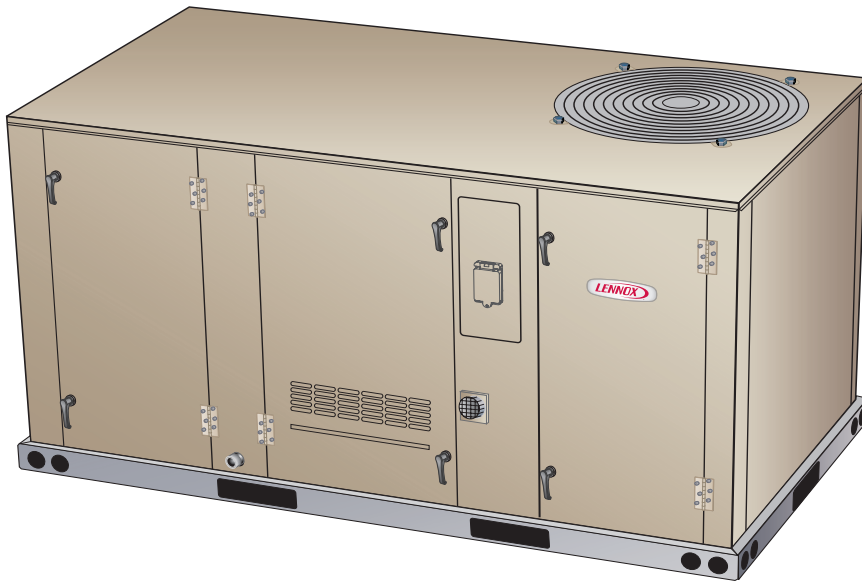

SMART WIRE™ SYSTEM



MODEL NUMBER IDENTIFICATION

L G M 060 U 5 E B 1 Y

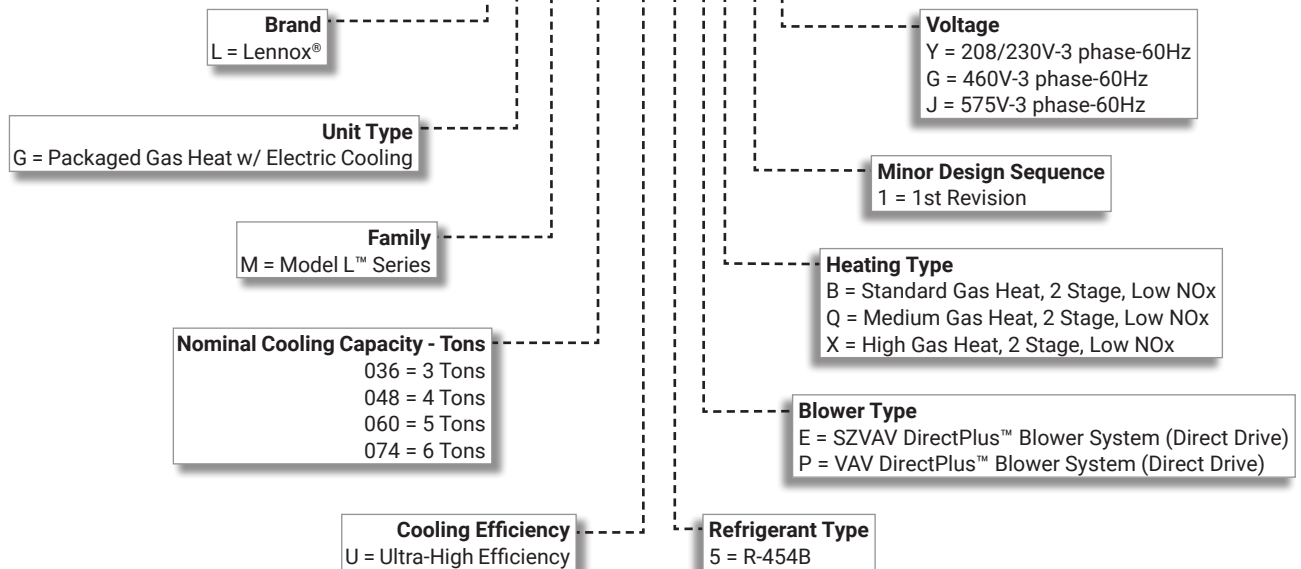

FEATURE HIGHLIGHTS

The Model L™ packaged rooftop line is engineered with advanced variable speed technology to offer some of the highest energy efficiencies in the industry while delivering superior temperature and humidity control in a wide variety of commercial applications.

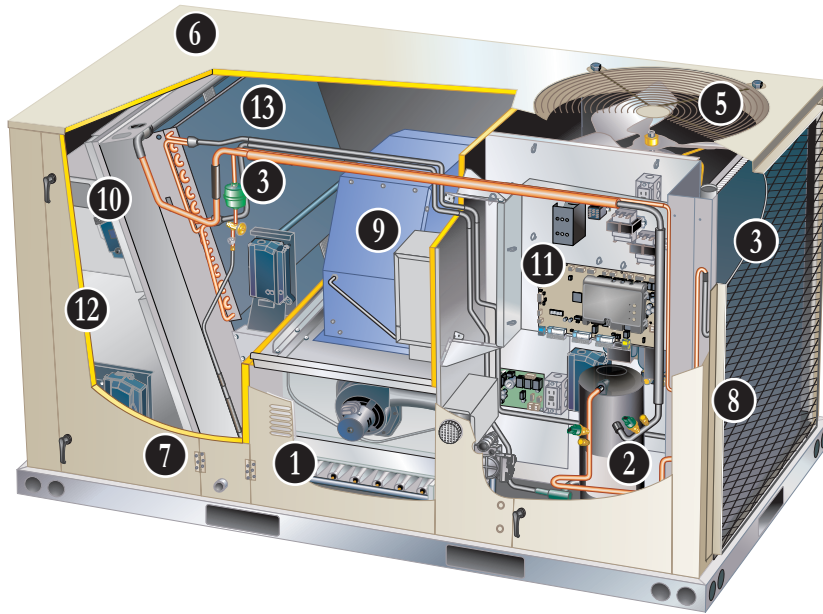

1. Heat Exchanger
2. Variable Capacity Scroll Compressor
3. Filter/Drier
4. Condenser Coil
5. Variable Speed ECM Outdoor Fan Motor
6. Heavy Gauge Steel Cabinet
7. Hinged Access Panels
8. Combination Coil/Hail Guards (option)
9. DirectPlus™ Direct Drive ECM Blower System
10. Air Filters
11. Lennox® CORE Control System
12. Economizer (option)
13. Humiditrol™+ Dehumidification System (option, not shown)

CONTENTS

Approvals And Warranty	3
Blower Data	30
Cooling Ratings	24
Dimensions	37
- Accessories	38
- Unit	37
Electrical Data	33
- 3 Ton	33
- 4 Ton	33
- 5 Ton	34
- 6 Ton	34
Features And Benefits	3
High Altitude Derate	23
Humiditrol™+ Dehumidification System Option	13
Humiditrol™+ System Ratings	28
Model Number Identification	1
Optional Conventional Temperature Control Systems	14
Options / Accessories	19
Outdoor Sound Data	35
Sequence Of Operation	16
Specifications	22
- Gas Heat	23
Unit Clearances	36
Weight Data	35
- Unit	35

APPROVALS AND WARRANTY

APPROVALS

- AHRI Certified to AHRI Standard 210/240-2023 (3 thru 5 ton models) and AHRI Standard 340/360-2023 (6 ton models)
- ETL and CSA listed
- Unit and components ETL, NEC and CEC bonded for grounding to meet safety standards for servicing
- All models are ASHRAE 90.1 compliant
- All models meet DOE 2023 energy efficiency standards and UL 60335-2-40 Refrigerant Detector Requirements
- All models have HCAI (formerly OSHPD) OSP and Special Seismic Certification ([Number: OSP-0596](#)), and meet 2021 International Building Code (IBC), 2022 California Building Code (CBC) ASCE 7, and ICC-ES AC156
- ENERGY STAR® certified units are designed to use less energy, help save money on utility bills, and help protect the environment
- ISO 9001 Registered Manufacturing Quality System

WARRANTY

- Aluminized Steel Heat Exchanger - Limited ten years
- Stainless Steel Heat Exchanger (optional) - Limited fifteen years
- Compressor - Limited five years
- Lennox® CORE Unit Controller - Limited three years
- High Performance Economizer (optional) - Limited five years
- All other covered components - Limited one year

FEATURES AND BENEFITS

HEATING SYSTEM

- Aluminized steel inshot burners
- Direct spark ignition
- Electronic flame sensor
- Combustion air inducer
- Redundant automatic dual stage gas valve with manual shut-off

1 Heat Exchanger

- Tubular construction, aluminized steel, life cycle tested

NOTE - Optional Stainless Steel Heat Exchanger is required if mixed air temperature is below 45°F.

Limit Controls

- Factory installed, redundant limit controls with fixed temperature setting
- Heat limit controls protect heat exchanger and other components from overheating

Safety Switches

- Flame roll-out switch, flame sensor and combustion air inducer proving switch protect system operation
- All safety switches are monitored by the Lennox® CORE Unit Controller and diagnostic information is reported and recorded

Low NOx Models

- All models are low NOx (40 ng/J)

Required Selections

Gas Input Choice - Order one:

- Standard Gas Heat (2 Stage) 53,000/65,000 Btuh
- Medium Gas Heat (2 Stage) 81,000/108,000 Btuh
- High Gas Heat (2 Stage) 113,000/150,000 Btuh

NOTE - All gas heat options are Low NOx (40 ng/J).

Options/Accessories

Factory Installed

Stainless Steel Heat Exchanger

- Required if mixed air temperature is below 45 °F

Vertical Vent Extension Kit

- Use to exhaust flue gases vertically above unit
- Required when unit vent is too close to fresh air intakes per building codes
- Prevents ice formation on intake louvers
- Kit contains vent transition, drain cap and installation hardware

NOTE - Straight vent pipe (3 in. B-Vent), vent tee and vent cap are not furnished and must be field supplied. Refer to kit instructions for additional information.

Combustion Air Intake Extensions

- Recommended for use with existing flue extension kits in areas where high snow can block intake air

LPG/Propane Kits

- Conversion kit to field change over units from Natural Gas to LPG/Propane

Field Installed

Low Temperature Vestibule Heater

- Extends gas heat operation from -40°F (standard) down to -60°F
- Electric heater automatically controls minimum temperature in gas burner compartment when temperature falls below -40°F

FEATURES AND BENEFITS

COOLING SYSTEM

- Designed to maximize sensible and latent cooling performance at design conditions
- System can operate from 0°F to 125°F without any additional controls

R-454B Refrigerant

- Low GWP (Global Warming Potential)
- Zero ODP (Ozone Depletion Potential)
- Low Toxicity/Lower Flammability - A2L
- Unit is factory pre-charged

2 Variable Capacity Scroll Compressor

- Operates on a variable frequency
- DC Inverter Control varies the capacity based on the cooling load required
- High volumetric efficiency
- Uniform suction flow
- Constant discharge flow
- "Soft Start" feature slowly ramps up system from low to high speed
- Quiet operation

Compressor Operation

- Two involute spiral scrolls matched together to generate a series of crescent shaped gas pockets between them
- During compression, one scroll remains stationary while the other scroll orbits around it
- Gas is drawn into the outer pocket, the pocket is sealed as the scroll rotates
- As the spiral movement continues, gas pockets are pushed to the center of the scrolls
- Volume between the pockets is simultaneously reduced
- When the pocket reaches the center, gas is now at high pressure and is forced out of a port located in the center of the fixed scrolls
- During compression, several pockets are compressed simultaneously resulting in a smooth continuous compression cycle
- Continuous flank contact, maintained by centrifugal force, minimizes gas leakage and maximizes efficiency
- Compressor is tolerant to the effects of slugging and contaminants
- If this occurs, scrolls separate, allowing liquid or contaminants to be worked toward the center and discharged

Top Cap Thermal Sensor Switch

- Located on top of the compressor casing
- Discontinues compressor operation in case of abnormal operating conditions

Compressor Crankcase Heater

- Protects against refrigerant migration that can occur during low ambient operation or during extended off cycles

DC Inverter Control

- Converts AC line voltage into filtered variable DC voltage
- Provides continuous compressor operation, while adjusting the capacity according to discharge air temperature
- Adjusts compressor output in increments as small as 1%
- Prevents frequent changes in capacity and ensures efficient, economical operation
- Power Factor Correction (PFC) circuit monitors the DC bus for high, low and abnormal voltage conditions to protect the compressor
- Two LEDs (red and green) indicate inverter operating status and aid in troubleshooting
- Noise filter reduces unwanted electromagnetic interference (EMI)
- Inverter reactor adds inductance to the line between the inverter and the compressor to limit current rise and protect the compressor

3 Environ™ Coil System

- Condenser and evaporator coil
- Coils feature lightweight, all aluminum brazed fin construction
- Constructed of three components:
 - A flat extrusion tube
 - Fins in-between the flat extrusion tube
 - Two refrigerant manifolds

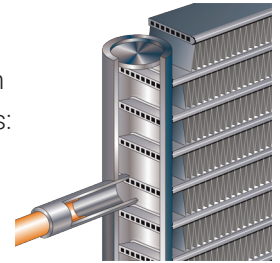

Environ™ Coil System Features:

- Improved heat transfer performance due to high primary surface area (flat tubes) versus secondary surface (fins)
- Smaller internal volume (reduced refrigerant charge)
- High durability
- All aluminum construction
- Fewer brazed joints
- Compact design
- Reduced unit weight
- Easy maintenance/cleaning
- Condenser coil has mounting brackets with rubber inserts which secures coil to unit providing vibration dampening and corrosion protection
- Hydrophilic fin surfaces on evaporator coil repel water and direct condensation down the surface into drain pan

Thermal Expansion Valve

- Ensures optimal performance throughout the application range
- Removable element head

4 Filter/Drier

- High capacity filter/drier protects the system from dirt and moisture

FEATURES AND BENEFITS

COOLING SYSTEM (continued)

High Pressure Switch

- Protects the compressor from overload conditions such as dirty condenser coils, blocked refrigerant flow or loss of outdoor fan operation

Low Pressure Switch

- Protects the compressor from low pressure conditions such as low refrigerant charge or low/no airflow

Indoor Coil Freeze Protection

- Protects the evaporator coil from damaging ice build-up due to conditions such as low/no airflow or low refrigerant charge

Anti-Microbial Condensate Drain Pan

- Plastic pan, sloped to meet drainage requirements of ASHRAE 62.1
- Anti-Microbial additive resists growth of mold and mildew on drain pan, which improves indoor air quality and reduces drain line blockage
- Side or bottom drain connections
- Reversible to allow connection at back of unit

5 Variable-Speed ECM Outdoor Fan Motor

- Fan speed is directly controlled by the Lennox® CORE Unit Controller
- Thermal overload protected
- Totally enclosed
- Permanently lubricated ball bearings
- Shaft up
- Wire basket mount

Outdoor Coil Fan

- PVC coated fan guard furnished

Required Selections

Cooling Capacity

- Specify nominal cooling capacity

Options/Accessories

Factory or Field Installed

Condensate Drain Trap

- Constructed of PVC (factory or field) or copper (field only)

NOTE - Trap is field installed only; PVC version may be factory ordered to ship with unit.

Drain Pan Overflow Switch

- Monitors condensate level in drain pan
- Shuts down unit if drain becomes clogged

LOW GWP REFRIGERANT DETECTION SYSTEM (RDS)

- Complies with UL 60335-2-40 approved standard
- Required for all systems using R-454B refrigerant
- Factory installed on all units
- Consists of a refrigerant detection sensor(s) and a mitigation control
- Ensures safe operation for systems equipped with R-454B refrigerant
- Sensor(s) monitors indoor coil area for R-454B refrigerant
- If R-454B refrigerant is detected the refrigerant detection system will prevent compressor and heating operation until R-454B refrigerant is no longer detected
- Refrigeration detection system energizes blower if any R-454B refrigerant is detected to mitigate any concentrations of refrigerant from the unit and the system

FEATURES AND BENEFITS

CABINET

6 Construction

- Heavy-gauge steel panels
- Full perimeter heavy-gauge galvanized steel base rail
- Base rails have rigging holes
- Three sides of the base rail have forklift slots
- Raised edges around duct and power entry openings in the bottom of the unit for water protection

Airflow Choice

- Units are shipped in downflow (vertical) configuration

NOTE - Can be field converted to horizontal airflow configuration without any optional kits.

Duct Flanges

- Provided for horizontal duct attachment

Power/Gas Entry

- Electrical and gas lines can be routed through the unit base or through horizontal access knock-outs

Exterior Panels

- Constructed of heavy-gauge, galvanized steel
- Textured pre-paint with polyurethane finish
- Cyclic salt fog and UV exposure up to 1,680 hours per ASTM D5894

Insulation

- Fully insulated with non-hygroscopic fiberglass insulation (conditioned areas)
- Unit base is fully insulated
- Base insulation serves as an air seal to the roof curb, eliminating the need to add a seal during installation

7 Hinged Access Panels

- Tool-less access
- Economizer/ Filter sections
- Blower/heating section
- Compressor/controls sections
- Panel seals and quarter-turn latching handles provide a tight air and water seal

NOTE - Optional Economizers, Power Exhaust, Outdoor Air Dampers and Barometric Relief Dampers include a filler panel for proper cabinet fit.

Required Selections

Airflow Configuration

- Specify horizontal or downflow

Options/Accessories

Factory Installed

Corrosion Protection

- Completely flexible immersed coating
- Electrodeposited dry film process (AST ElectroFin E-Coat)
- ASTM B117 / DIN 53167 Salt Spray - 15,000+ hours
- ASTM G85 Annex A3 SWAAT Modified Salt Spray - 3000 hours

- VA Master Construction Specification Division 23 for High Humidity Installations
- CID AA-52474A (GSA)
- Indoor Corrosion Protection:
 - Coated coil
 - Coated reheat coil (Humiditrol™+)
 - Painted blower housing
 - Painted indoor base
- Outdoor Corrosion Protection:
 - Coated coil
 - Painted outdoor base

Factory or Field Installed

8 Combination Coil/Hail Guards

- Heavy gauge steel frame
- Painted to match cabinet
- Expanded metal mesh protects outdoor coil

FEATURES AND BENEFITS

BLOWER

9 DirectPlus™ Direct Drive ECM Blower System

- High-efficiency, variable-speed ECM (electronically commutated) motor
- Eliminates the need for a separate variable-frequency drive
- Advanced Blower Diagnostics: Lennox® CORE Unit Controller communicates via Modbus with DirectPlus™ blower to provide control commands, blower proving functionality, and detailed alarm codes
- SZVAV equipped models modulate the amount of supply blower airflow according to cooling demand, heating demand, ventilation demand or smoke alarm
- The amount of airflow for each stage can be set according to a parameter in the Lennox® CORE Unit Controller
- Unit is shipped from the factory with preset airflows
- Fully variable speed motor modulates to maximize system efficiency
- Combines the motor and electronics into one unit
- Aerodynamically optimized impeller
- Backward curved blades mounted directly onto the rotor



- Air inlet grill reduces indoor sound levels without affecting air performance

Supply Static Pressure Transducer (VAV Models Only)

- Sends information to the Lennox® CORE Unit Controller to control blower speed to the desired supply duct static pressure
- Shipped with the unit for remote field installation in the supply duct

Required Selections

Blower Selection

- SZVAV (Single Zone Variable Air Volume) controls the speed of the blower based on the cooling and heating demands
- VAV (Variable Air Volume) blower varies the air volume to maintain a constant supply duct static pressure

ELECTRICAL

SmartWire™ System

- Keyed and color-coded wiring connectors prevent miswiring
- Wire coloring scheme is standardized across all models
- Each connection is intuitively labeled to make troubleshooting and servicing quick and easy

Electrical Plugs

- Positive connection electrical plugs are used to connect common accessories or maintenance parts for easy removal or installation

Required Selections

Voltage Choice

- Specify when ordering base unit

Options/Accessories

Factory Installed

Circuit Breakers

- HACR type
- For overload and short circuit protection
- Factory wired and mounted in the power entry panel
- Current sensitive and temperature activated
- Manual reset

Phase/Voltage Detection (3 Phase models only)

- Monitors power supply to assure phase is correct at unit start-up
- If phase is incorrect, the unit will not start and an alarm code is reported to the unit controller
- Protects unit from being started with incorrect phasing which could lead to issues such as compressors running backwards
- Voltage detection monitors power supply voltage to assure proper voltage
- If voltage is not correct (over/under voltage conditions) the unit will not start and an alarm code is reported to the unit controller

Short-Circuit Current Rating (SCCR)

- Higher short circuit protection up to 100kA

NOTE - Disconnect Switch is furnished and factory installed with High SCCR option.

Factory or Field Installed

Disconnect Switch

- Accessible outside of unit
- Spring loaded weatherproof cover furnished

GFI Service Outlets (2)

- 115V ground fault circuit interrupter (GFCI) type options
 - Factory installed, non-powered, field wired
 - Field installed, non-powered, field wired

Field Installed

GFI Weatherproof Cover

- Single-gang cover
- Heavy-duty UV-resistant polycarbonate case construction
- Hinged base cover with gasket

CONTROL SYSTEM

INDOOR AIR QUALITY

10

Air Filters

- Disposable 2 inch MERV 4 filters furnished as standard

Options/Accessories

Factory or Field Installed

Healthy Climate® High Efficiency Air Filters

- Disposable MERV 8, MERV 13, or MERV 16 (Minimum Efficiency Reporting Value based on ASHRAE 52.2) efficiency 2-inch pleated filters

Field Installed

Healthy Climate® UVC Germicidal Lamps

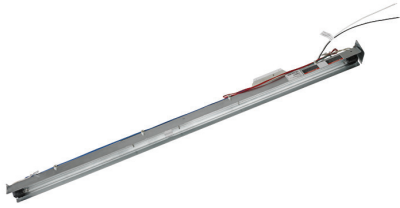

- Germicidal lamps emit ultra-violet (UV-C) energy, which has been proven to be effective in reducing microbes such as viruses, bacteria, yeasts, and molds
- This process either destroys the organism or controls its ability to reproduce
- UV-C energy greatly reduces the growth and proliferation of mold and other bioaerosols (bacteria and viruses) on illuminated surfaces (particularly coil and drain pan)
- Installed in the blower/evaporator coil section
- Safety interlock switch automatically shuts off power to the UVC light when panel is removed
- Interlock switch is factory installed or field installed in the blower/evaporator coil section panel
- All necessary hardware for installation is included
- Lamps operate on 110/230V, 1 phase power supply
- Approved by ETL

NOTE - Step-down transformer may be ordered for field installed UVC lamps when used with 460V and 575V rooftop units. Step-down transformer is furnished with lamps when factory installed.

Needlepoint Bipolar Ionization (NPBI) Kit

- NPBI technology integrates with system controls for effective air treatment
- Ionization has been shown to effectively reduce harmful pathogens, pollutants and odors

NOTE - Please visit www.sciencedirect.com for additional information.

- Brush-type ionizer introduces a high concentration of both positive and negative ions into the air stream
- These bipolar ions are then dispersed into the occupied space through the duct system proactively reducing the airborne contaminants
- Ions travel within the building air stream and attach to particles, pathogens, and gas molecules, making them larger and easier to capture in the filtration system
- UL 2998 certified for zero ozone emission

Replacement Filter Media Kit With Frame

- Replaces existing pleated filter media
- Includes washable metal mesh screen and metal frame with clip for holding replaceable non-pleated filter

Indoor Air Quality (CO₂) Sensors

- Monitors CO₂ levels
- Reports to the Lennox® CORE Unit Controller, which adjusts economizer dampers as needed

CONTROL SYSTEM

LENNOX® CORE CONTROL SYSTEM

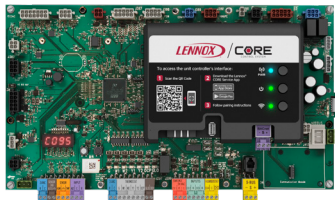

The Lennox® CORE Control system is designed to accelerate equipment install and service. Standard with all Model L™ rooftop units, control system integrates key technologies that lower installation costs, drive system efficiency, and protect your investments.

- 11** The Lennox® CORE Unit Controller is a microprocessor-based controller that provides flexible control of all unit functions.

CORE Mobile Service App

- Guided Setup with progress indicators, detailed help, and exportable summaries to manage simple, trouble-free setup, reducing commissioning times
- Enhanced Test Functionality provides real-time sensor readings, trending, and reports that enable easy troubleshooting
- Ability to set and configure parameters of the CORE Control System to manage sequence of operation
- Economizer test function ensures economizer is operating correctly



Additional Features:

- Built-In 7-Segment Display shows Unit Status and active alarms for easy troubleshooting
- Buttons for test and clearing delays
- SmartWire™ System with keyed and removable screw terminals ensure correct field wiring
- Built-in BACnet MS/TP and IP allow open integration to building management systems
- Two-port Ethernet Switch enables daisy chaining for BACnet IP and automatic firmware updates

NOTE - Unit Internet Connection required.

- Profile setup copies key settings between units with the same configuration to reduce setup time
- USB port allows a technician to download and transfer unit information to help verify service was performed
- USB software updates on the Lennox® CORE Unit Controller enhance functionality without the need to change components
- Unit Controller Software

Configurable Built-In Functions

- Full modulation of variable speed compressor for discharge air temperature control in room sensor or thermostat mode
- Discharge Air Cooling Control

OPTIONS / ACCESSORIES

- Up to three distinct Cooling Airflows in Thermostat Mode
- Programmable independent heating, ventilation and cooling blower speeds
- Discharge Air Heating Control
- Economizer Control Options (See Economizer / Exhaust Air / Outdoor Air sections)
- Exhaust Fan Control Modes for fresh air damper position
- Configurable Morning Warm-up
- Night Setback Mode
- Fresh Air Tempering for Improved Ventilation
- Demand Control Ventilation
- Low Ambient Controls for operation down to 0°F
- Humiditrol™+ Operation
- Enhanced Dehumidification (Latent Demand Control without reheat)

Component Protection / Unit Safeguards:

- Compressor Time-Off Delay
- Adjustable Blower On/Off Delay
- Return Air Temperature Limit Control
- Safety Switch Input allows Controller to respond to a external safety switch trip
- Service Relay Output
- Thermostat Bounce Delay
- Smoke Alarm Mode has four choices (unit off, positive pressure, negative pressure, purge)
- "Strike Three" Protection
- Gas Valve Time Delay Between First and Second Stage
- Minimum Compressor Run Time

Control Methods / Interfaces:

- DDC and 24V Thermostat
- BACnet MS/TP and IP
- LONTalk (Factory and Field Option)
- Lennox SBUS
- Zone Temperature Sensor Input
- Dehumidistat and Humidity Sensor Inputs
- Indoor Air Quality Inputs (2)
- Built-in Control Parameter Defaults
- Permanent Diagnostic Code Storage
- Field Adjustable Control Parameters (Over 200 settings)
- Multiple Configurable Digital Inputs
- LED Indicators
- PC Interface connects the Lennox® CORE Unit Controller to a PC with the Lennox Unit Controller Software

NOTE - Lennox® CORE Control System features vary with the type of rooftop unit in which the control is installed.

OPTIONS / ACCESSORIES

LENNOX® CORE CONTROL SYSTEM (continued)

Controls Options

Factory or Field Installed

Dirty Filter Switch

- Senses static pressure increase and issues alarm if necessary

Fresh Air Tempering

- Used in applications with high outside air requirements
- Controller energizes the first stage heat as needed to maintain a minimum supply air temperature for comfort, regardless of the thermostat demand
- When ordered as a factory option, sensor ships with the unit for field installation

Smoke Detector

- Photoelectric type
- Installed in supply air section, return air section or both sections
- Available with power board and single sensor (supply or return) or power board and two sensors (supply and return)
- Power board located in unit control compartment

COMMERCIAL CONTROL SYSTEMS

Interoperability via BACnet® or LonTalk® Protocols

- Communication compatible with third-party automation systems that support the BACnet Application Specific Controller device profile, LonMark® Space Comfort Controller functional profile, or LonMark Discharge Air Controller functional profile

Field Installed

Thermostats and Room Sensors

- Control system and thermostat options, see Page 14
- After-Market unit controller options

ECONOMIZER

- 12 • Economizer operation is set and controlled by the Lennox® CORE Unit Controller
- Simple plug-in connections from economizer to unit controller for easy installation
- All Model L™ rooftop units are equipped with factory installed CEC Title 24 approved sensors for outside, return and discharge air temperature monitoring

NOTE - Optional sensors may be used instead of unit sensors to determine whether outdoor air is suitable for free cooling. See Options/Accessories table.

Factory or Field Installed

High Performance Economizer

- Approved for California Title 24 building standards
- Low leakage dampers are Air Movement and Control Association International (AMCA) Class 1A Certified - Maximum 3 CFM per sq. ft. leakage at 1 in. w.g.
- ASHRAE 90.1 and IECC compliant
- Combination Outdoor Air Hood is furnished
- Factory installed Economizer can be ordered with three exhaust options:

- Barometric Relief Dampers
- Power Exhaust Fan

NOTE - See Power Exhaust Fan section for additional requirements.

- No Exhaust
- Field installed Economizer includes Barometric Relief Dampers with Combination Hood
- Barometric Relief Dampers allow relief of excess air
- Dampers prevent blow back and outdoor air infiltration during off cycle
- Bird screen furnished

NOTE - Barometric Relief Dampers are required when Economizer is factory installed with factory installed Power Exhaust Fan option. See Power Exhaust Fan section and Options/Accessories table.

NOTE - Horizontal Barometric Dampers are required for horizontal Economizer applications and must be ordered separately

- Demand Control Ventilation (DCV) ready using optional CO₂ sensors
- Linked damper action
- High torque 24-volt fully-modulating spring return damper motor
- Return air and outdoor air dampers
- Plug-in connections to unit

OPTIONS / ACCESSORIES

ECONOMIZER (continued)

NOTE - High Performance Economizers are not approved for use with enthalpy controls in Title 24 applications.

NOTE - The Free Cooling setpoint for Title 24 applications must be set based on the Climate Zone where the system is installed. See Section 140.4 "Prescriptive Requirements for Space Conditioning Systems" of the California Energy Commission's 2022 Building Energy Efficiency Standards.

NOTE - Refer to Installation Instructions for complete setup information.

Differential Sensible Control

- Factory setting
- Uses outdoor air and return air sensors that are furnished with the unit
- The Lennox® CORE Unit Controller compares outdoor air and return air and using setpoints
- Enables the economizer when the outdoor air temperature is below the configured setpoint and cooler than return air

NOTE - Differential Sensible Control can be configured in the field to provide Offset Differential Sensible Control or Single Sensible Control.
In Offset Differential Sensible Control mode, the economizer is enabled if the temperature differential (offset) between outdoor air and return air reaches the configured setpoint.
In Single Sensible Control mode, the economizer is enabled when outdoor air temperature falls below the configured setpoint.

Global Control

- The unit controller communicates with a DDC system with one global sensor (enthalpy or sensible) to determine whether outside air is suitable for free cooling on all units connected to the control system
- Sensor must be field provided

NOTE - Global control with enthalpy is not approved for Title 24 applications.

Single Enthalpy Temperature Control (Not for Title 24)

- Outdoor air enthalpy sensor enables Economizer if the outdoor enthalpy is less than the setpoint of the control

Differential Enthalpy Control (Not for Title 24)

- Order two Single Enthalpy Controls:
 - One is field installed in the return air section
 - One in the outdoor air section
- Allows the economizer control to select between outdoor air or return air, whichever has lower enthalpy

Field Installed

Outdoor Air CFM Control

- Maintains constant outdoor air volume levels on the supply air fan and varying unit airflows
- References a velocity sensor located in the rooftop unit outdoor air section
- Lennox® CORE Unit Controller changes the economizer position to help minimize the effect of supply fan speed changes on outdoor air volume levels
- Setpoint for outdoor air volume is established by field testing

NOTE - Not available with Demand Control Ventilation (CO₂ Sensor) or Building Pressure Control.

Building Pressure Control

- Maintains constant building pressure level
- Using differential pressure information between the outdoor air and the building air, the Lennox® CORE Unit Controller changes the economizer position to help maintain a constant building pressure

NOTE - Not available with Demand Control Ventilation (CO₂ Sensor).

Horizontal Barometric Relief Dampers

- For use when unit is configured for horizontal applications with an economizer
- Allows relief of excess air
- Blade type dampers prevent blow back and outdoor air infiltration during off cycle
- Field installed in return air duct
- Outdoor air hood with bird screen included
- Exhaust hood with bird screen furnished
- Requires Horizontal Economizer Conversion Kit

Horizontal Economizer Conversion Kit

- Insulated panel covers the bottom return air opening on the unit base to convert downflow economizer to horizontal air flow

OPTIONS / ACCESSORIES

EXHAUST

Factory or Field Installed

Power Exhaust Fan

- Installs internal to unit for downflow applications with economizer option
- Provides exhaust air pressure relief
- Interlocked to run when supply air blower is operating
- Fan runs when outdoor air dampers are 50% open (adjustable)
- Motor is overload protected
- Fan is 16 in. diameter
- Four fan blades
- 1/3 HP motor

NOTE - If Power Exhaust is field installed with a factory installed Economizer, the Economizer must be ordered with No Exhaust option. Barometric Relief Dampers must also be ordered separately for field installation.

NOTE - If Power Exhaust is factory installed with a factory installed Economizer, Barometric Relief Dampers must also be ordered separately for field installation.

OUTDOOR AIR

Factory or Field Installed

Motorized Outdoor Air Dampers

- Linked mechanical dampers
- Fully modulating spring return damper motor with plug-in connection
- 0 to 25% (fixed) outdoor air adjustable
- Installs in unit
- Outdoor air hood with bird screen included

NOTE - Outdoor Air Hood is shipped separately in the unit with factory installed dampers for field installation.

Field Installed

Manual Outdoor Air Damper

- Adjustable slide damper
- Installed in unit
- Outdoor air hood with bird screen included

ROOF CURBS

Field Installed

- Nailer strip furnished (downflow only)
- Mates to unit
- US National Roofing Contractors Approved
- Shipped knocked down

Hybrid Roof Curbs, Downflow

- Interlocking tabs fasten corners together
- No tools required for assembly
- Can also be fastened together with furnished hardware
- Available in 8, 14, 18, and 24 inch heights

Adjustable Pitch Curb

- Fully adjustable pitch curbs (3/4 in. per foot in any direction) provide a level platform for rooftop units allowing flexible installations on roofs with uneven or sloped angles
- Interlocking tabs fasten corners together
- No tools required for assembly
- Hardware is furnished to connect upper curb with lower curb
- Available in 14 inch height

Adaptor Curbs (not shown)

- Curbs are regionally sourced
- Dimensions vary based upon the source

NOTE - Contact your local sales representative for a detailed cut sheet with applicable dimensions.

CEILING DIFFUSERS

Field Installed

Ceiling Diffusers (Flush or Step-Down)

- White powder coat finish on diffuser face and grilles
- Insulated UL listed duct liner
- Diffuser box has collars for duct connection
- Step-down diffusers have double deflection blades
- Flush diffusers have fixed blades
- Provisions for suspending
- Internally sealed to prevent recirculation
- Removable return air grille
- Adapts to T-bar ceiling grids or plaster ceilings

Transitions (Supply and Return)

- Used with diffusers
- Installs in roof curb
- Galvanized steel construction
- Flanges furnished for duct connection to diffusers
- Fully insulated

HUMIDITROL™ + DEHUMIDIFICATION SYSTEM OPTION

OVERVIEW

- Factory installed hot gas reheat option designed to control humidity
- 13 • Humiditrol™+ utilizes advanced control algorithms, variable speed technology and a reheat coil to efficiently control humidity levels independent of room temperature
- Provides dehumidification on demand using ASHRAE 90.1 recommended method for comfort conditioning humidity control
- Unit comes equipped with one row reheat coil and solenoid valve

NOTE - A dehumidification demand from a relative humidity sensor, dehumidistat, a DDC controller or building automation system is required to control humidity.

BENEFITS

- Improves indoor air quality
- Discharge air control for overcool protection
- Adjustable discharge air temperature setpoint
- Energy efficient dehumidification
- Modulating latent and sensible capacity
- Helps prevent damage due to high humidity levels
- Improves comfort levels by reducing space humidity levels

OPERATION

No Dehumidification Demand

- The unit will operate conventionally whenever there is a demand for cooling or heating and no dehumidification demand
- Free cooling is only permitted when there is no demand for dehumidification

Dehumidification Demand Only

- Reheat operation will initiate on a dehumidification demand and does not require a cooling demand
- The unit will operate in hot gas reheat dehumidification mode until the relative humidity of the conditioned space is below the setpoint
- A solenoid valve diverts hot gas from the compressor to the reheat coil
- The cooled and dehumidified air from the evaporator is reheated as it passes through the reheat coil
- The de-superheated and partially condensed refrigerant continues to the outdoor condenser coil where condensing is completed
- Unit will continue to operate in this mode until the dehumidification demand is satisfied
- The reheat coil is sized to provide optimal reheat performance without overheating supply air
- The compressor will modulate based on dehumidification load
- The outdoor fan modulates speed to provide discharge air temperature control in reheat mode

Dehumidification and Cooling Demand

- If both a dehumidification and a cooling demand occur, the system will operate in cooling until the cooling demand is satisfied
- Then the system will energize the dehumidification mode

NOTE - See Sequence of Operation for additional information.

TYPICAL DEHUMIDIFICATION SCHEMATIC

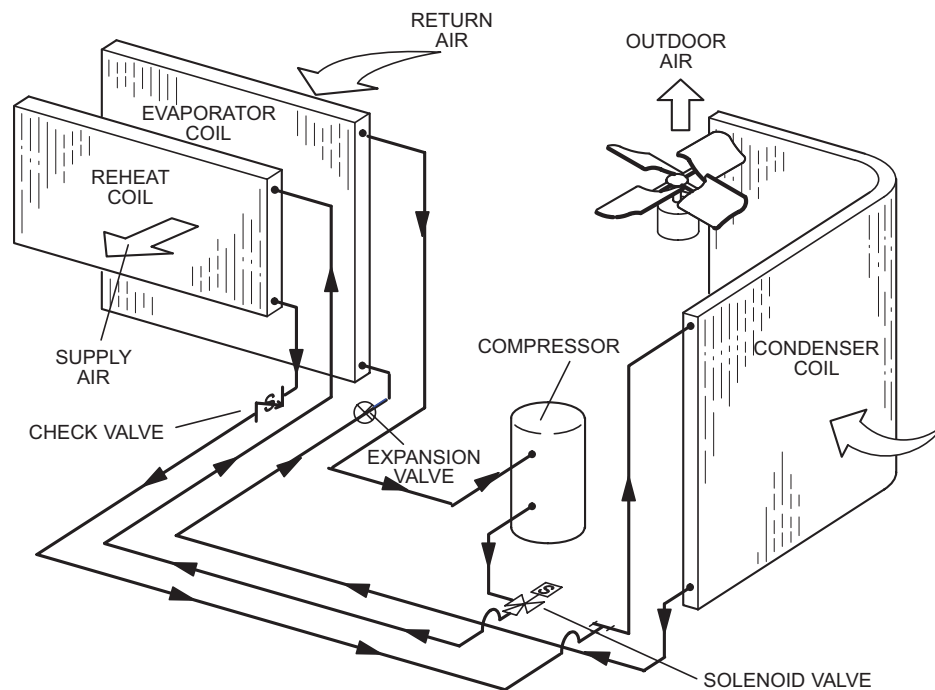

OPTIONAL CONVENTIONAL TEMPERATURE CONTROL SYSTEMS

CS8500 Commercial 7-Day Programmable Thermostat

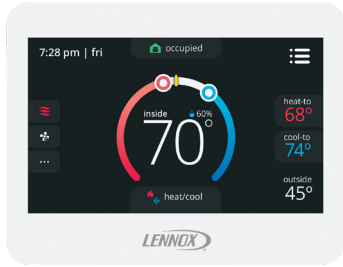

- Fully Communicating Sensor
- Full Color Touchscreen Interface
- Variable Speed System Control (On Compatible Units)
- Up To 4 Heat / 4 Cool
- Built-In Sensors For Temperature, Humidity And Optional CO₂
- Remote Sensor Options For Occupancy, Temperature
- BACnet Capable Options
- 5-2 or 7-Day Scheduling
- Smooth Setback Recovery
- Heat/Cool Auto-Changeover
- Four-Wire Installation
- FDD, ASHRAE, IECC Compliant

CS7500 Commercial 7-Day Programmable Thermostat



- Premium Universal Thermostat
- Full Color Touchscreen Interface
- Up To 4 Heat / 3 Cool
- Built-In Sensors For Temperature and Humidity
- Remote Sensors Options For Temperature, Discharge Air, Outdoor Air
- 5-2 or 7-Day Scheduling
- Smooth Setback Recovery
- Heat/Cool Auto-Changeover
- FDD, ASHRAE, IECC Compliant

CS3000 Commercial 5-2 Day Programmable Thermostat



- Conventional Multi-Stage Thermostat
- Intuitive Display
- Push-Button Operation
- Up To 2 Heat / 2 Cool
- Built-In Temperature Sensor
- Remote Temperature Sensing
- Up to 5-2 Day Scheduling
- Smooth Setback Recovery
- Heat/Cool Auto-changeover

Wired Temperature/Humidity Room Sensor (Non-Communicating)



- Terminal blocks for wiring connections
- Five-wire sensor connection
- Off-white plastic enclosure
- Non-adjustable
- Relative humidity range: 0 -100%
- +/- 3% Accuracy

OPTIONAL CONVENTIONAL TEMPERATURE CONTROL SYSTEMS

Description	Order Number
CS8500 Commercial 7 Day Programmable Thermostat	
CS8500 7-Day Thermostat	No CO ₂ Sensing 24K55
	With CO ₂ Sensing 24K53
Sensors/Accessories	¹ Remote non-adjustable wall-mount 10k 47W37
	¹ Remote non-adjustable wall-mount 11k 94L61
Sysbus Network Cable (Yellow) for CS8500 and LCS-5030 Wired Room Sensor	
Twisted pair 100% shielded communication cable, Red and Black	500 ft. box 27M19
22 AWG, yellow jacket, rated at 75°C, 300V, Plenum rated	1000 ft. box 94L63
Insulation - Low smoke PVC, NEC, CMP	2500 ft. roll 68M25
CS7500 Commercial 7-Day Programmable Thermostat	
CS7500 7-Day Thermostat	24K41
Sensors/Accessories	² Remote non-adjustable wall-mount 20k 47W36
	² Remote non-adjustable wall-mount 10k 47W37
	Remote non-adjustable discharge air (duct mount) 19L22
	Outdoor temperature sensor X2658
CS3000 Commercial 5-2 Day Programmable Thermostat	
CS3000 5-2 Day Thermostat	11Y05
Sensors/Accessories	Remote non-adjustable wall mount 10k averaging 47W37
	Thermostat wall mounting plate X2659
Universal Thermostat Guard with Lock (clear)	
	Inside Dimensions (H x W x D) 5-7/8 x 8-3/8 x 3 in. 39P21
Temperature/Humidity Room Sensor	
A335MT13AE1 Wired Temperature/Humidity Room Sensor (Non-Communicating)	21W06

¹ Up to nine of the same type remote temperature sensors can be connected in parallel.

² Remote wall-mount sensors can be applied in any of the following combinations:
 One Sensor - (1) 47W36, Two Sensors - (2) 47W37, Three Sensors - (2) 47W36 and (1) 47W37
 Four Sensors - (4) 47W36, Five Sensors - (3) 47W36 and (2) 47W37

SEQUENCE OF OPERATION

COOLING

A-Two-Stage Thermostat

1 - Economizer With Outdoor Air Suitable

Y1 Demand

- Compressor Off
- Blower Low
- Dampers Modulate

Y2 Demand

- Compressor Modulates
- Blower Low
- Dampers Full Open

NOTE - Compressor is energized after damper has been at full open for three minutes.

2 - No Economizer or Outdoor Air Not Suitable

Y1 Demand

- Compressor Modulates
- Blower Low
- Dampers Minimum Position

Y2 Demand

- Compressor Modulates
- Blower High
- Dampers Minimum Position

B-Three-Stage Thermostat

1 - Economizer With Outdoor Air Suitable

Y1 Demand

- Compressors Off
- Blower Low
- Dampers Modulate

Y2 Demand

- Compressor Modulates
- Blower Low
- Dampers Full Open

NOTE - Compressor is energized after damper has been at full open for three minutes.

Y3 Demand

- Compressor Modulates
- Blower High
- Dampers Full Open

SEQUENCE OF OPERATION

COOLING (CONTINUED)

2 - No Economizer or Outdoor Air Not Suitable

Y1 Demand

- Compressor Modulates
- Blower Low
- Dampers Minimum Position

Y2 Demand

- Compressor Modulates
- Blower Mid
- Dampers Minimum Position

Y3 Demand

- Compressor Modulates
- Blower High
- Dampers Minimum Position

C-Zone Sensor

1 - Economizer With Outdoor Air Suitable

Low Cooling Demand

- Compressor Off
- Blower Variable
- Dampers Modulate

High Cooling Demand

- Compressor Modulates
- Blower Variable
- Dampers Full Open

NOTE - Compressor is energized after damper has been at full open for three minutes.

NOTE - Free cooling is locked out when a dehumidification demand is received. The unit operates in dehumidification mode as if the outdoor air is not suitable.

2 - No Economizer or Outdoor Air Not Suitable

Any Demand

- Compressor Modulates
- Blower Variable
- Damper Minimum Position

HEATING

Heating Mode: Thermostat or Zone Sensor (Up to 2 stages W1, W2)

W1 or Low Heating Demand

Gas valve is open on low and the supply fan operates at high speed.

W2 or High Heating Demand

Gas valve is open on high and the supply fan operates at high speed.

SEQUENCE OF OPERATION

HUMIDITROL™+

A - Thermostat Mode With 24V Humidistat

Dehumidification Demand (DI4) and No Cooling Demand

Compressor operates at 100%, blower and outdoor fan modulate to maintain indoor coil and discharge air temperatures, reheat valve is energized.

Y1 and DI4 Demand

Compressor is modulating, blower is on low, and the reheat valve is de-energized.

Y2 and DI4 Demand

Compressor is modulating, blower is on high, reheat valve is de-energized.

B - Thermostat Mode With Zone Relative Humidity Sensor

Dehumidification Demand (Zone Relative Humidity is greater than the relative humidity setpoint) and No Cooling Demand

Compressor modulates based on zone relative humidity, blower and outdoor fan modulate to maintain indoor coil and discharge air temperatures, reheat valve is energized.

Y1 and Dehumidification Demand

Compressor is modulating, blower is on low, and the reheat valve is de-energized.

Y2 and Dehumidification Demand

Compressor is modulating, blower is on high, reheat valve is de-energized.

C - Zone Sensor Mode With Humidistat

Dehumidification Demand (DI4) and No Cooling Demand

Compressor operates at 100%, blower and outdoor fan modulate to maintain indoor coil and discharge air temperatures, reheat valve is energized.

Cooling and Dehumidification Demand

Compressor is modulating, blower is modulating, reheat valve is de-energized.

D - Zone Sensor Mode With Zone Relative Humidity Sensor

Dehumidification Demand (Zone Relative Humidity is greater than the relative humidity setpoint) and No Cooling Demand

Compressor modulates based on zone relative humidity, blower and outdoor fan modulate to maintain indoor coil and discharge air temperatures, reheat valve is energized.

Cooling and Dehumidification Demand

Compressor is modulating, blower is modulating, and the reheat valve is de-energized.

OPTIONS / ACCESSORIES

Item	Order Number	Size				
		036	048	060	074	
COOLING SYSTEM						
Condensate Drain Trap	PVC	22H54	OX	OX	OX	OX
	Copper	76W27	X	X	X	X
Drain Pan Overflow Switch		21Z07	OX	OX	OX	OX
HEATING SYSTEM						
Bottom Gas Piping Kit		19W50	OX	OX	OX	OX
Combustion Air Intake Extensions		19W51	X	X	X	X
Gas Heat Input	Standard Two-Stage - 53/65 kBtuh input	Factory	O	O	O	O
	Medium Two Stage - 81/108 kBtuh input	Factory	O	O	O	O
	High Two-Stage - 113/150 kBtuh input	Factory		O	O	O
Low Temperature Vestibule Heater	208/230V-3ph	21Z17	X	X	X	X
	460V-3ph	21Z18	X	X	X	X
	575V-3ph	21Z19	X	X	X	X
LPG/Propane Conversion Kits	For two-stage standard models	21Z24	X	X	X	X
	For two-stage medium and high models	21Z23	X	X	X	X
Stainless Steel Heat Exchanger		Factory	O	O	O	O
Vertical Vent Extension		31W62	X	X	X	X
BLOWER - SUPPLY AIR						
Motors	DirectPlus™ Direct Drive ECM Blower System with MSAV®	Factory	O	O	O	O
	DirectPlus™ Direct Drive ECM Blower System with VAV	Factory	O	O	O	O
CABINET						
Combination Coil/Hail Guards		13T03	OX	OX	OX	OX
Corrosion Protection (indoor coil / outdoor coil)		Factory	O	O	O	O
CONTROLS						
Commercial Controls	Lennox® CORE Control System - LonTalk® Module	54W27	OX	OX	OX	OX
	CPC Einstein Integration	Factory	O	O	O	OX
	Novar® LSE	Factory	O	O	O	O
Dirty Filter Switch		53W66	OX	OX	OX	OX
Fresh Air Tempering		21Z08	OX	OX	OX	OX
Smoke Detector - Supply or Return (Power board and one sensor)		21Z11	OX	OX	OX	OX
Smoke Detector - Supply and Return (Power board and two sensors)		21Z12	OX	OX	OX	OX
ELECTRICAL						
Voltage 60 Hz	208/230V - 3ph	Factory	O	O	O	O
	460V - 3ph	Factory	O	O	O	O
	575V-3ph	Factory	O	O	O	O
HACR Circuit Breakers		Factory	O	O	O	O
¹ Short-Circuit Current Rating (SCCR) of 100kA (includes Phase/Voltage Detection)		Factory	O	O	O	O
Disconnect Switch	80 amp	22A25	OX	OX	OX	OX
GFI Service Outlets	15 amp non-powered, field-wired (208/230V, 460V only)	74M70	OX	OX	OX	OX
	² 20 amp non-powered, field-wired (208/230V, 460V, 575V)	67E01	X	X	X	X
	² 20 amp non-powered, field-wired (575V only)	Factory	O	O	O	O
Weatherproof Cover for GFI		10C89	X	X	X	X
Phase/Voltage Detection - 3 Phase Models Only		Factory	O	O	O	O

¹ Disconnect Switch is furnished and factory installed with High SCCR option.

² Canada requires a minimum 20 amp circuit. Select 20 amp, non-powered, field wired GFI.

OPTIONS / ACCESSORIES

Item	Order Number	Size			
		036	048	060	074
ECONOMIZER					
High Performance Economizer With Outdoor Air Hood (Sensible Control) (Approved for California Title 24 Building Standards / AMCA Class 1A Certified)					
High Performance Economizer - Includes Barometric Relief Dampers and Combination Hood	20H48	OX	OX	OX	OX
High Performance Economizer - No Exhaust Option	Factory	O	O	O	O
Economizer Accessories					
Horizontal Economizer Conversion Kit	17W45	X	X	X	X
Economizer Controls					
Differential Enthalpy (Not for Title 24)	Order 2 21Z09	OX	OX	OX	OX
Sensible Control	Sensor is Furnished Factory	O	O	O	O
Single Enthalpy (Not for Title 24)	21Z09	OX	OX	OX	OX
Outdoor Air CFM Control	13J76	X	X	X	X
Global Control	Sensor Field Provided Factory	O	O	O	O
Building Pressure Control	13J77	X	X	X	X
POWER EXHAUST FAN					
Standard Static	208/230V-3ph 21Z13	OX	OX	OX	OX
<i>NOTE - Factory installed Power Exhaust Fan requires "Barometric Relief Dampers for Power Exhaust Kit" for field installation. See below.</i>	460V-3ph 21Z14	OX	OX	OX	OX
	575V-3ph 21Z15	OX	OX	OX	OX
BAROMETRIC RELIEF					
² Barometric Relief Dampers for Power Exhaust Kit	21Z21	X	X	X	X
³ Horizontal Barometric Relief Dampers With Outdoor Air and Exhaust Hood	19F01	X	X	X	X
OUTDOOR AIR					
Outdoor Air Dampers With Outdoor Air Hood					
Motorized	15D17	OX	OX	OX	OX
Manual	15D18	X	X	X	X
HUMIDITROL™+ HOT GAS REHEAT OPTION					
Humiditrol™+ Dehumidification Option	Factory	O	O	O	O
³ Required when Economizer is factory installed with factory installed Power Exhaust Fan option.					
⁴ Required when Economizer is configured for horizontal airflow.					

OPTIONS / ACCESSORIES

Item	Order Number	Size				
		036	048	060	074	
INDOOR AIR QUALITY						
Air Filters						
Healthy Climate® High Efficiency Air Filters 20 x 20 x 2 in.	MERV 8 (Order 4)	54W21	OX	OX	OX	OX
	MERV 13 (Order 4)	52W39	OX	OX	OX	OX
	MERV 16 (Order 4)	21U40	OX	OX	OX	OX
Replaceable Media Filter With Metal Mesh Frame 20 x 20 x 2 in. (includes non-pleated filter media)	(Order 4)	44N60	X	X	X	X
Needlepoint Bipolar Ionization (NPBI)						
Needlepoint Bipolar Ionization Kit		21U35	X	X	X	X
Indoor Air Quality (CO₂) Sensors						
Sensor - Wall-mount, off-white plastic cover with LCD display		77N39	X	X	X	X
Sensor - Wall-mount, off-white plastic cover, no display		23V86	X	X	X	X
Sensor - Black plastic case, LCD display, rated for plenum mounting		87N52	X	X	X	X
Sensor - Black plastic case, no display, rated for plenum mounting		87N54	X	X	X	X
CO ₂ Sensor Duct Mounting Kit - for downflow applications		85L43	X	X	X	X
Aspiration Box - for duct mounting non-plenum rated CO ₂ sensors (77N39)		90N43	X	X	X	X
UVC Germicidal Lamps						
⁴ Healthy Climate® UVC Light Kit (110/230V-1ph)		21A92	X	X	X	X
Step-Down Transformer	460V primary, 230V secondary	10H20	X	X	X	X
	575V primary, 230V secondary	10H21	X	X	X	X
ROOF CURBS						
Hybrid Roof Curbs, Downflow						
8 in. height		11F50	X	X	X	X
14 in. height		11F51	X	X	X	X
18 in. height		11F52	X	X	X	X
24 in. height		11F53	X	X	X	X
Adjustable Pitched Curb						
14 in. height		43W27	X	X	X	X
Transition Curb						
Matches Model L™ 036-074 Units to existing L Series® Curbs		31B05	X	X	X	X
CEILING DIFFUSERS						
Step-Down - Order one	RTD9-65S	13K60	X	X	X	
	RTD11-95S	13K61				X
Flush - Order one	FD9-65S	13K55	X	X	X	
	FD11-95S	13K56				X
Transitions (Supply and Return) - Order one	T1TRAN10AN1	17W53	X	X	X	
	T1TRAN20N-1	17W54				X

⁵ Lamps operate on 110-230V single-phase power supply. Step-down transformer may be ordered separately for 460V and 575V units. Alternately, 110V power supply may be used to directly power the UVC ballast(s).

SPECIFICATIONS		UNIT			
Model		LGM036U5E	LGM048U5E	LGM060U5E	LGM074U5E
Blower Type		DirectPlus™ ECM Direct Drive with SZVAV	DirectPlus™ ECM Direct Drive with SZVAV	DirectPlus™ ECM Direct Drive with SZVAV	DirectPlus™ ECM Direct Drive with SZVAV
Model Number		LGM036U5P	LGM048U5P	LGM060U5P	LGM074U5P
Blower Type		DirectPlus™ ECM Direct Drive with VAV	DirectPlus™ ECM Direct Drive with VAV	DirectPlus™ ECM Direct Drive with VAV	DirectPlus™ ECM Direct Drive with VAV
Efficiency Type		Ultra-High	Ultra-High	Ultra-High	Ultra-High
Nominal Tonnage		3 Ton	4 Ton	5 Ton	6 Ton
Cooling Performance	Gross Cooling Capacity (Btuh)	36,000	48,500	60,000	71,000
	¹ Net Cooling Capacity (Btuh)	35,000	48,000	58,000	69,000
	AHRI Rated Air Flow (cfm)	1320	1600	1850	2150
	SEER2 (Btuh/Watt)	21.2	19.9	19.5	---
	EER2 (Btuh/Watt)	14.3	13.2	12.5	---
	IEER (Btuh/Watt)	---	---	---	23.1
	EER (Btuh/Watt)	---	---	---	12.2
	Total Unit Power - kW	2.5	3.6	4.6	5.5
Sound Rating Number	dBa	73	76	78	80
Refrigerant Charge	Refrigerant Type	R-454B	R-454B	R-454B	R-454B
	Without Reheat Option	4 lbs. 8 oz.	5 lbs. 1 oz.	5 lbs. 1 oz.	5 lbs. 1 oz.
	With Reheat Option	5 lbs. 11 oz.	5 lbs. 9 oz.	5 lbs. 9 oz.	5 lbs. 9 oz.
Gas Heating Options		See Page 23			
Compressor Type (Number)		Variable Capacity Scroll (1)			
Outdoor Coil	Net face area - ft. ²	17.8	17.8	17.8	17.8
	Rows	1	1	1	1
	Fins - in.	23	23	23	23
Outdoor Coil Fans	Motor HP (number and type)	1/3 (1 ECM)	1/3 (1 ECM)	1/3 (1 ECM)	1/3 (1 ECM)
	Rpm	550 - 850	600 - 900	700 - 950	700 - 1050
	Watts	50 - 200	80 - 236	120 - 272	120 - 360
	Diameter (Number) - in.	(1) 24	(1) 24	(1) 24	(1) 24
	Blades	3	3	3	3
	Total air volume - cfm	2500 - 3850	2750 - 4100	3200 - 4300	3200 - 4700
Indoor Coil	Net face area - ft. ²	8.65	8.65	8.65	8.65
	Rows	1	1	1	1
	Fins - in.	20	20	20	20
	Condensate drain size (NPT) - in.	(1) 1			
	Expansion device type	Balanced Port Thermostatic Expansion Valve,removable power head			
Indoor Blower	Motor HP (number and type)	1.5 HP (1 ECM)	1.5 HP (1 ECM)	1.5 HP (1 ECM)	1.5 HP (1 ECM)
	Wheel (Number) diameter x width - in.	(1) 14 x 5	(1) 14 x 5	(1) 14 x 5	(1) 14 x 5
Filters	Type of filter	MERV 4, Disposable			
	Number and size - in.	(4) 20 x 20 x 2			
Line voltage data (Volts-Phase-Hz)		208/230-3-60, 460-3-60, 575-3-60			

NOTE - Net capacity includes evaporator blower motor heat deduction. Gross capacity does not include evaporator blower motor heat deduction.

¹ AHRI Certified to AHRI Standard 210/240 (3-5 ton) or 340/360 (6 ton): 95°F outdoor air temperature and 80°F db/67°F wb entering evaporator air; minimum external duct static pressure.

SPECIFICATIONS GAS HEAT

Model		036, 048 060, 074	036, 048 060, 074	048 060, 074
Heat Input Type		Standard (2 Stage)	Medium (2 Stage)	High (2 Stage)
Input Btuh	1st Stage	53,000	81,000	113,000
	2nd Stage	65,000	108,000	150,000
Output Btuh	1st Stage	43,000	66,000	92,000
	2nd Stage	52,000	87,000	121,000
Temperature Rise Range - °F	1st stage	5 - 35	25 - 55	30 - 60
	2nd Stage	15 - 45	30 - 70	45 - 75
¹ Thermal Efficiency		81%	81%	81%
Gas Supply Connections		1/2 in. NPT		
Recommended Gas Supply Pressure - Nat. / LPG		7 in. w.g. / 11 in. w.g.		
Gas Supply Pressure Range	Min./Max. (Natural)	4.5 - 10.5 in. w.g.		
	Min./Max. (LPG)	10.8 - 13.5 in. w.g.		

¹ Thermal Efficiency at full input.

HIGH ALTITUDE DERATE

NOTE - Units may be installed at altitudes up to 2000 ft. above sea level without any modifications. At altitudes above 2000 ft. units must be derated 2% for each 1000 ft. above sea level.	Heat Input Type	Altitude Feet	Gas Manifold Pressure in. w.g.		Input Rate (Btuh)
			Natural Gas	LPG/Propane	
NOTE - This is the only permissible derate for these units. Refer to the Installation Instructions for more detailed information.	Standard (2 stage)	2001 - 4500	3.0/1.7	9.0/5.1	60,000 / 49,000
	Medium (2 stage)	2001 - 4500	3.0/1.7	9.0/5.1	100,000 / 75,000
	High (2 stage)	2001 - 4500	3.0/1.7	9.0/5.1	139,000 / 104,000

COOLING RATINGS

NOTE – For Temperatures and Capacities not shown in tables, see bulletin – Cooling Unit Rating Table Correction Factor Data in Miscellaneous Engineering Data section.

4 TON - LGM048U5E/P

Entering Wet Bulb Temperature	Total Air Volume	Outdoor Air Temperature Entering Outdoor Coil																	
		65°F						75°F						85°F					
		Total Cooling Cap.	Comp. Motor Input	Dis-charge Air Temp.	Sensible To Total Ratio (S/T)			Total Cooling Cap.	Comp. Motor Input	Dis-charge Air Temp.	Sensible To Total Ratio (S/T)			Total Cooling Cap.	Comp. Motor Input	Dis-charge Air Temp.	Sensible To Total Ratio (S/T)		
					Dry Bulb						Dry Bulb						Dry Bulb		
		cfm	kBtuh	kW	°F	75°F	80°F	85°F	kBtuh	kW	°F	75°F	80°F	85°F	kBtuh	kW	°F	75°F	80°F
63°F	850	43.9	12.9	1.97	.67	.76	.85	42.6	12.5	2.29	.67	.77	.86	41.3	12.1	2.68	.68	.78	.88
	1000	46.4	13.6	1.95	.68	.79	.90	44.9	13.2	2.28	.69	.80	.91	43.4	12.7	2.62	.70	.81	.92
	1150	48.3	14.2	1.92	.71	.82	.94	46.8	13.7	2.27	.71	.84	.95	45.3	13.3	2.62	.72	.85	.97
	1300	50.0	14.7	1.90	.73	.86	.98	48.5	14.2	2.26	.74	.87	.99	46.7	13.7	2.62	.75	.89	1.00
	1600	52.8	15.5	1.87	.78	.93	1.00	51.0	14.9	2.23	.79	.95	1.00	49.3	14.4	2.61	.80	.96	1.00
	1900	55.2	16.2	1.84	.83	.99	1.00	53.5	15.7	2.21	.85	1.00	1.00	51.8	15.2	2.59	.86	1.00	1.00
67°F	850	47.0	13.8	1.93	.55	.64	.72	45.6	13.4	2.28	.55	.64	.73	44.2	13.0	2.62	.55	.65	.74
	1000	49.7	14.6	1.90	.56	.66	.75	48.2	14.1	2.27	.56	.66	.76	46.5	13.6	2.62	.56	.67	.78
	1150	51.8	15.2	1.88	.57	.68	.79	50.2	14.7	2.25	.57	.69	.80	48.5	14.2	2.61	.58	.70	.81
	1300	53.6	15.7	1.86	.58	.70	.82	51.8	15.2	2.22	.59	.71	.84	49.9	14.6	2.60	.59	.72	.85
	1600	56.2	16.5	1.83	.61	.75	.89	54.3	15.9	2.20	.62	.76	.91	52.2	15.3	2.58	.63	.78	.93
	1900	58.1	17.0	1.80	.64	.81	.96	56.1	16.4	2.19	.65	.82	.98	54.0	15.8	2.59	.66	.84	1.00
71°F	850	50.6	14.8	1.90	.44	.52	.61	49.0	14.4	2.26	.44	.53	.61	47.5	13.9	2.61	.44	.53	.62
	1000	53.4	15.6	1.86	.44	.53	.63	51.7	15.2	2.23	.44	.54	.63	50.0	14.7	2.60	.45	.54	.64
	1150	55.6	16.3	1.83	.45	.55	.65	53.8	15.8	2.21	.45	.55	.66	51.9	15.2	2.59	.45	.56	.67
	1300	57.3	16.8	1.81	.45	.56	.67	55.4	16.2	2.19	.45	.57	.68	53.4	15.6	2.58	.45	.57	.70
	1600	60.1	17.6	1.77	.46	.59	.73	57.9	17.0	2.17	.46	.60	.74	55.8	16.4	2.57	.47	.61	.75
	1900	62.1	18.2	1.74	.47	.63	.78	59.8	17.5	2.15	.48	.64	.79	57.4	16.8	2.56	.48	.65	.81
Entering Wet Bulb Temperature	Total Air Volume	Outdoor Air Temperature Entering Outdoor Coil																	
		95°F						105°F						115°F					
		Total Cooling Cap.	Comp. Motor Input	Dis-charge Air Temp.	Sensible To Total Ratio (S/T)			Total Cooling Cap.	Comp. Motor Input	Dis-charge Air Temp.	Sensible To Total Ratio (S/T)			Total Cooling Cap.	Comp. Motor Input	Dis-charge Air Temp.	Sensible To Total Ratio (S/T)		
					Dry Bulb						Dry Bulb						Dry Bulb		
		cfm	kBtuh	kW	°F	75°F	80°F	85°F	kBtuh	kW	°F	75°F	80°F	85°F	kBtuh	kW	°F	75°F	80°F
63°F	850	39.8	11.7	2.99	.68	.79	.89	38.3	11.2	3.44	.69	.80	.91	36.7	10.8	3.88	.70	.81	.93
	1000	41.9	12.3	2.99	.71	.82	.94	40.2	11.8	3.38	.72	.84	.96	38.6	11.3	3.88	.73	.86	.98
	1150	43.5	12.7	2.98	.73	.86	.99	41.8	12.3	3.38	.75	.88	1.00	39.9	11.7	3.81	.76	.90	1.00
	1300	44.9	13.2	2.99	.76	.91	1.00	43.1	12.6	3.38	.78	.93	1.00	41.2	12.1	3.81	.79	.95	1.00
	1600	47.4	13.9	2.99	.82	.98	1.00	45.7	13.4	3.39	.84	1.00	1.00	43.9	12.9	3.83	.86	1.00	1.00
	1900	50.1	14.7	2.98	.88	1.00	1.00	48.3	14.2	3.40	.90	1.00	1.00	46.3	13.6	3.84	.93	1.00	1.00
67°F	850	42.7	12.5	2.99	.56	.65	.75	41.1	12.0	3.38	.56	.66	.76	39.3	11.5	3.81	.57	.67	.78
	1000	44.9	13.2	2.99	.57	.68	.79	43.1	12.6	3.38	.58	.69	.80	41.2	12.1	3.81	.58	.70	.82
	1150	46.7	13.7	2.99	.58	.71	.83	44.7	13.1	3.39	.59	.72	.85	42.6	12.5	3.82	.60	.73	.87
	1300	48.0	14.1	2.99	.60	.74	.87	46.0	13.5	3.39	.61	.75	.89	43.9	12.9	3.83	.62	.77	.91
	1600	50.2	14.7	2.98	.64	.80	.95	48.0	14.1	3.40	.65	.81	.97	45.7	13.4	3.84	.66	.84	1.00
	1900	51.9	15.2	2.98	.67	.85	1.00	49.6	14.5	3.40	.69	.88	1.00	47.2	13.8	3.84	.70	.90	1.00
71°F	850	45.9	13.5	2.99	.44	.53	.62	44.1	12.9	3.38	.44	.54	.63	42.3	12.4	3.82	.45	.54	.64
	1000	48.2	14.1	2.99	.45	.55	.65	46.3	13.6	3.39	.45	.55	.66	44.3	13.0	3.83	.45	.56	.67
	1150	50.0	14.7	2.98	.45	.56	.68	47.9	14.0	3.40	.45	.57	.69	45.8	13.4	3.84	.46	.58	.71
	1300	51.5	15.1	2.98	.46	.58	.71	49.4	14.5	3.40	.46	.59	.72	47.1	13.8	3.84	.47	.60	.74
	1600	53.6	15.7	2.97	.47	.62	.77	51.3	15.0	3.40	.48	.63	.79	48.9	14.3	3.85	.48	.65	.81
	1900	55.1	16.1	2.97	.49	.66	.83	52.7	15.4	3.40	.49	.67	.85	50.2	14.7	3.86	.50	.69	.88

RATINGS

NOTE – For Temperatures and Capacities not shown in tables, see bulletin – Cooling Unit Rating Table Correction Factor Data in Miscellaneous Engineering Data section.

5 TON - LGM060U5E/P

Entering Wet Bulb Temperature	Total Air Volume	Outdoor Air Temperature Entering Outdoor Coil																	
		65°F						75°F						85°F					
		Total Cooling Cap.	Comp. Motor Input	Dis-charge Air Temp.	Sensible To Total Ratio (S/T)			Total Cooling Cap.	Comp. Motor Input	Dis-charge Air Temp.	Sensible To Total Ratio (S/T)			Total Cooling Cap.	Comp. Motor Input	Dis-charge Air Temp.	Sensible To Total Ratio (S/T)		
					Dry Bulb						Dry Bulb						Dry Bulb		
		cfm	kBtuh	kW	°F	75°F	80°F	85°F	kBtuh	kW	°F	75°F	80°F	85°F	kBtuh	kW	°F	75°F	80°F
63°F	950	53.8	15.8	2.55	.66	.74	.83	52.0	15.2	2.92	.66	.75	.84	50.3	14.7	3.32	.66	.76	.85
	1150	57.5	16.9	2.54	.67	.77	.87	55.5	16.3	2.92	.68	.78	.89	53.6	15.7	3.34	.69	.79	.90
	1300	59.7	17.5	2.53	.69	.80	.91	57.6	16.9	2.92	.70	.81	.92	55.7	16.3	3.35	.71	.82	.94
	1750	64.7	19.0	2.51	.75	.88	1.00	62.2	18.2	2.91	.76	.90	1.00	59.9	17.6	3.34	.77	.92	1.00
	2050	66.9	19.6	2.50	.79	.94	1.00	64.6	18.9	2.91	.80	.96	1.00	62.3	18.3	3.34	.82	.98	1.00
	2300	69.0	20.2	2.49	.82	.98	1.00	66.4	19.5	2.90	.84	1.00	1.00	64.3	18.8	3.34	.85	1.00	1.00
67°F	950	57.6	16.9	2.54	.54	.63	.71	55.7	16.3	2.92	.55	.63	.71	53.9	15.8	3.34	.55	.64	.72
	1150	61.4	18.0	2.53	.55	.65	.74	59.3	17.4	2.92	.56	.65	.75	57.3	16.8	3.34	.56	.66	.76
	1300	63.7	18.7	2.51	.56	.66	.76	61.5	18.0	2.91	.57	.67	.78	59.3	17.4	3.34	.57	.68	.79
	1750	68.7	20.1	2.49	.59	.72	.85	66.1	19.4	2.90	.60	.73	.86	63.6	18.6	3.34	.61	.75	.88
	2050	71.0	20.8	2.47	.62	.76	.91	68.1	20.0	2.90	.63	.78	.93	65.5	19.2	3.34	.63	.79	.94
	2300	72.4	21.2	2.46	.64	.80	.95	69.5	20.4	2.89	.65	.81	.97	67.0	19.6	3.34	.66	.83	.99
71°F	950	61.6	18.1	2.52	.44	.52	.60	59.7	17.5	2.92	.44	.52	.60	57.7	16.9	3.34	.44	.52	.61
	1150	65.7	19.3	2.51	.44	.53	.62	63.5	18.6	2.91	.44	.53	.62	61.3	18.0	3.34	.44	.54	.63
	1300	68.1	20.0	2.49	.44	.54	.63	65.7	19.3	2.90	.45	.54	.64	63.3	18.6	3.34	.45	.55	.65
	1750	73.2	21.5	2.46	.45	.57	.69	70.4	20.6	2.89	.46	.58	.71	67.8	19.9	3.34	.46	.59	.72
	2050	75.5	22.1	2.44	.46	.60	.74	72.6	21.3	2.88	.47	.61	.75	69.9	20.5	3.34	.47	.62	.77
	2300	77.0	22.6	2.43	.47	.62	.77	74.0	21.7	2.87	.48	.63	.79	71.1	20.8	3.34	.48	.64	.81
Entering Wet Bulb Temperature	Total Air Volume	Outdoor Air Temperature Entering Outdoor Coil																	
		95°F						105°F						115°F					
		Total Cooling Cap.	Comp. Motor Input	Dis-charge Air Temp.	Sensible To Total Ratio (S/T)			Total Cooling Cap.	Comp. Motor Input	Dis-charge Air Temp.	Sensible To Total Ratio (S/T)			Total Cooling Cap.	Comp. Motor Input	Dis-charge Air Temp.	Sensible To Total Ratio (S/T)		
					Dry Bulb						Dry Bulb						Dry Bulb		
		cfm	kBtuh	kW	°F	75°F	80°F	85°F	kBtuh	kW	°F	75°F	80°F	85°F	kBtuh	kW	°F	75°F	80°F
63°F	950	48.6	14.2	3.76	.67	.77	.86	46.9	13.7	4.30	.68	.78	.88	44.8	13.1	4.81	.68	.79	.89
	1150	51.7	15.2	3.79	.70	.81	.92	49.7	14.6	4.28	.70	.82	.93	47.5	13.9	4.83	.72	.84	.96
	1300	53.6	15.7	3.80	.72	.84	.96	51.4	15.1	4.29	.73	.85	.97	49.1	14.4	4.85	.74	.87	1.00
	1750	57.8	16.9	3.84	.78	.93	1.00	55.3	16.2	4.32	.80	.96	1.00	52.9	15.5	4.88	.82	.98	1.00
	2050	59.9	17.6	3.81	.83	1.00	1.00	57.7	16.9	4.33	.85	1.00	1.00	55.4	16.2	4.91	.87	1.00	1.00
	2300	62.1	18.2	3.82	.87	1.00	1.00	59.8	17.5	4.34	.89	1.00	1.00	57.3	16.8	4.93	.92	1.00	1.00
67°F	950	52.1	15.3	3.79	.55	.64	.73	50.1	14.7	4.28	.55	.65	.74	47.9	14.0	4.83	.56	.66	.75
	1150	55.4	16.2	3.82	.56	.67	.77	53.1	15.6	4.30	.57	.68	.78	50.7	14.9	4.86	.57	.69	.80
	1300	57.3	16.8	3.83	.57	.69	.80	54.8	16.1	4.32	.58	.70	.82	52.3	15.3	4.88	.59	.71	.84
	1750	61.1	17.9	3.82	.61	.76	.90	58.5	17.1	4.33	.62	.77	.92	55.8	16.4	4.91	.64	.79	.95
	2050	62.9	18.4	3.82	.64	.81	.97	60.2	17.6	4.35	.66	.83	.99	57.5	16.9	4.93	.67	.85	1.00
	2300	64.2	18.8	3.83	.67	.85	1.00	61.5	18.0	4.37	.68	.87	1.00	58.5	17.1	4.94	.70	.90	1.00
71°F	950	55.9	16.4	3.82	.44	.53	.61	53.7	15.7	4.31	.44	.53	.62	51.4	15.1	4.87	.44	.54	.63
	1150	59.1	17.3	3.82	.45	.54	.64	56.8	16.6	4.33	.45	.55	.65	54.3	15.9	4.90	.45	.55	.66
	1300	61.0	17.9	3.82	.45	.55	.66	58.5	17.1	4.33	.45	.56	.67	56.0	16.4	4.91	.45	.57	.68
	1750	65.1	19.1	3.83	.46	.60	.73	62.5	18.3	4.36	.47	.61	.75	59.4	17.4	4.94	.47	.62	.77
	2050	67.0	19.6	3.83	.48	.63	.78	64.0	18.8	4.37	.48	.64	.80	61.0	17.9	4.95	.49	.66	.82
	2300	68.2	20.0	3.84	.49	.66	.83	65.2	19.1	4.37	.49	.67	.85	61.9	18.1	4.96	.50	.69	.87

RATINGS

NOTE – For Temperatures and Capacities not shown in tables, see bulletin – Cooling Unit Rating Table Correction Factor Data in Miscellaneous Engineering Data section.

6 TON - LGM074U5E/P

Entering Wet Bulb Temperature	Total Air Volume	Outdoor Air Temperature Entering Outdoor Coil																	
		65°F						75°F						85°F					
		Total Cooling Cap.	Comp. Motor Input	Dis-charge Air Temp.	Sensible To Total Ratio (S/T)			Total Cooling Cap.	Comp. Motor Input	Dis-charge Air Temp.	Sensible To Total Ratio (S/T)			Total Cooling Cap.	Comp. Motor Input	Dis-charge Air Temp.	Sensible To Total Ratio (S/T)		
					Dry Bulb						Dry Bulb						Dry Bulb		
cfm	kBtuh	kW	°F	75°F	80°F	85°F	kBtuh	kW	°F	75°F	80°F	85°F	kBtuh	kW	°F	75°F	80°F	85°F	
63°F	950	58.6	17.2	3.10	.65	.73	.81	56.7	16.6	3.52	.65	.74	.82	54.9	16.1	4.04	.66	.74	.83
	1200	64.0	18.8	3.11	.67	.76	.86	61.8	18.1	3.53	.67	.77	.87	59.6	17.5	3.99	.68	.78	.88
	1500	68.8	20.2	3.12	.70	.81	.92	66.1	19.4	3.55	.71	.82	.93	63.7	18.7	4.01	.71	.83	.95
	1750	71.6	21.0	3.12	.72	.85	.97	68.9	20.2	3.56	.73	.86	.99	66.5	19.5	4.03	.75	.88	1.00
	2050	74.7	21.9	3.12	.76	.90	1.00	71.9	21.1	3.56	.77	.92	1.00	69.2	20.3	4.05	.78	.93	1.00
	2300	76.6	22.4	3.12	.79	.94	1.00	73.9	21.7	3.57	.80	.96	1.00	71.2	20.9	4.05	.82	.98	1.00
67°F	950	62.8	18.4	3.11	.54	.62	.69	60.9	17.8	3.53	.54	.62	.70	58.9	17.3	3.99	.54	.63	.71
	1200	68.6	20.1	3.12	.55	.64	.73	66.2	19.4	3.55	.55	.64	.74	63.9	18.7	4.02	.56	.65	.75
	1500	73.4	21.5	3.12	.56	.67	.77	70.8	20.7	3.56	.57	.68	.79	68.2	20.0	4.04	.57	.69	.80
	1750	76.5	22.4	3.12	.58	.70	.81	73.6	21.6	3.57	.59	.71	.83	70.9	20.8	4.05	.59	.72	.84
	2050	79.3	23.2	3.12	.60	.73	.86	76.2	22.3	3.57	.61	.75	.88	73.3	21.5	4.06	.61	.76	.90
	2300	81.1	23.8	3.11	.62	.76	.91	78.1	22.9	3.58	.63	.78	.93	75.1	22.0	4.07	.64	.79	.95
71°F	950	67.5	19.8	3.12	.45	.52	.59	65.4	19.2	3.54	.44	.52	.59	63.3	18.6	4.01	.44	.52	.60
	1200	73.5	21.5	3.12	.44	.53	.61	71.0	20.8	3.56	.44	.53	.62	68.6	20.1	4.04	.44	.53	.62
	1500	78.6	23.0	3.12	.44	.54	.64	75.8	22.2	3.57	.45	.55	.65	73.0	21.4	4.06	.45	.55	.66
	1750	81.7	23.9	3.11	.45	.56	.67	78.7	23.1	3.58	.45	.57	.68	75.8	22.2	4.08	.45	.57	.69
	2050	84.5	24.8	3.10	.46	.58	.71	81.4	23.9	3.58	.46	.59	.72	78.4	23.0	4.09	.46	.60	.73
	2300	86.6	25.4	3.11	.46	.60	.74	83.3	24.4	3.59	.47	.61	.75	79.9	23.4	4.09	.47	.62	.77
Entering Wet Bulb Temperature	Total Air Volume	Outdoor Air Temperature Entering Outdoor Coil																	
		95°F						105°F						115°F					
		Total Cooling Cap.	Comp. Motor Input	Dis-charge Air Temp.	Sensible To Total Ratio (S/T)			Total Cooling Cap.	Comp. Motor Input	Dis-charge Air Temp.	Sensible To Total Ratio (S/T)			Total Cooling Cap.	Comp. Motor Input	Dis-charge Air Temp.	Sensible To Total Ratio (S/T)		
					Dry Bulb						Dry Bulb						Dry Bulb		
cfm	kBtuh	kW	°F	75°F	80°F	85°F	kBtuh	kW	°F	75°F	80°F	85°F	kBtuh	kW	°F	75°F	80°F	85°F	
63°F	950	53.1	15.6	4.55	.66	.75	.84	51.1	15.0	5.15	.67	.76	.85	48.9	14.3	5.83	.67	.77	.87
	1200	57.5	16.9	4.50	.69	.79	.90	55.3	16.2	5.08	.70	.81	.92	53.0	15.5	5.84	.71	.82	.93
	1500	61.5	18.0	4.55	.72	.85	.97	59.0	17.3	5.12	.74	.87	.99	56.3	16.5	5.77	.75	.89	1.00
	1750	64.1	18.8	4.58	.76	.90	1.00	61.4	18.0	5.14	.77	.92	1.00	58.6	17.2	5.80	.79	.94	1.00
	2050	66.7	19.5	4.61	.80	.95	1.00	63.8	18.7	5.17	.81	.98	1.00	61.1	17.9	5.83	.83	1.00	1.00
	2300	68.6	20.1	4.59	.83	.99	1.00	66.1	19.4	5.19	.85	1.00	1.00	63.5	18.6	5.86	.87	1.00	1.00
67°F	950	56.9	16.7	4.50	.55	.63	.72	54.9	16.1	5.08	.55	.64	.72	52.6	15.4	5.84	.55	.64	.73
	1200	61.7	18.1	4.56	.56	.66	.76	59.3	17.4	5.13	.56	.67	.77	56.7	16.6	5.77	.57	.68	.78
	1500	65.9	19.3	4.60	.58	.70	.81	63.0	18.5	5.16	.59	.71	.83	60.3	17.7	5.82	.59	.72	.85
	1750	68.2	20.0	4.59	.60	.73	.86	65.4	19.2	5.19	.61	.74	.88	62.4	18.3	5.85	.62	.76	.90
	2050	70.4	20.6	4.60	.62	.77	.92	67.5	19.8	5.20	.63	.79	.94	64.6	18.9	5.87	.64	.81	.96
	2300	72.0	21.1	4.61	.64	.81	.97	68.9	20.2	5.21	.66	.83	.99	65.9	19.3	5.89	.67	.85	1.00
71°F	950	61.2	17.9	4.55	.44	.52	.60	58.9	17.3	5.12	.44	.52	.61	56.6	16.6	5.77	.44	.53	.61
	1200	66.3	19.4	4.61	.44	.54	.63	63.7	18.7	5.17	.45	.54	.64	61.0	17.9	5.83	.45	.55	.65
	1500	70.3	20.6	4.60	.45	.56	.67	67.5	19.8	5.20	.45	.57	.68	64.6	18.9	5.88	.45	.57	.69
	1750	72.8	21.3	4.62	.46	.58	.70	69.9	20.5	5.22	.46	.59	.72	66.8	19.6	5.90	.46	.60	.73
	2050	75.2	22.0	4.64	.47	.61	.75	72.0	21.1	5.24	.47	.62	.76	68.7	20.1	5.92	.48	.63	.78
	2300	76.8	22.5	4.65	.48	.63	.78	73.6	21.6	5.28	.48	.64	.80	70.2	20.6	5.94	.49	.66	.82

1.5 HP

BLOWER DATA
BLOWER TABLE INCLUDES RESISTANCE FOR BASE UNIT ONLY WITH DRY INDOOR COIL AND AIR FILTERS IN PLACE.

FOR ALL UNITS ADD:

- 1 - Any factory installed options air resistance (heat section, economizer, etc.).
- 2 - Any field installed accessories air resistance (duct resistance, diffuser, etc.).

Minimum Air Volume Required For Different Gas Heat Sizes:

Standard Heat - 1075 cfm; Medium Heat - 1150 cfm; High Heat - 1500 cfm

See Page 32 for wet coil and options/accessory air resistance data.

DOWNFLOW

Total Air cfm	Total Static Pressure - in. w.g.																												
	0.1		0.2		0.3		0.4		0.5		0.6		0.7		0.8		0.9		1.0		1.1		1.2		1.3				
	RPM	Watts	RPM	Watts	RPM	Watts	RPM	Watts	RPM	Watts	RPM	Watts	RPM	Watts	RPM	Watts	RPM	Watts	RPM	Watts	RPM	Watts	RPM	Watts	RPM	Watts	RPM	Watts	
400	---	---	734	19	823	40	910	60	985	78	---	---	---	---	---	---	---	---	---	---	---	---	---	---	---	---	---		
600	766	28	856	51	944	73	1029	93	1108	111	1180	127	1248	139	1315	149	1383	158	1451	169	---	---	---	---	---	---	---		
800	899	57	989	81	1079	104	1163	125	1242	145	1317	161	1386	174	1454	185	1519	198	1582	214	1643	234	1701	255	1755	281			
1000	1084	95	1163	117	1244	139	1323	160	1398	180	1470	196	1538	211	1603	227	1663	245	1721	267	1776	292	1828	320	1876	350			
1200	1319	113	1385	138	1451	162	1517	186	1581	209	1644	231	1703	254	1759	278	1812	306	1863	337	1912	367	1960	397	2003	427			
1400	1542	146	1596	177	1649	208	1703	239	1757	269	1809	300	1860	331	1909	362	1956	393	2003	425	2050	456	2095	483	2139	508			
1600	1721	225	1772	258	1823	291	1873	324	1923	356	1972	388	2019	419	2065	450	2110	480	2156	510	2200	539	2244	565	2287	590			
1800	1909	309	1957	341	2006	373	2054	404	2101	435	2146	465	2190	495	2234	526	2277	557	2320	588	2362	620	2404	651	2444	685			
2000	2103	385	2148	417	2193	450	2239	483	2283	516	2325	550	2367	584	2408	620	2449	658	2490	696	2529	735	2568	777	2605	822			
2200	2299	478	2342	514	2384	552	2426	590	2467	630	2507	671	2547	714	2586	757	2625	800	2663	844	2700	889	2735	935	2770	982			
2400	2500	606	2540	647	2580	690	2618	734	2656	779	2694	824	2731	870	2768	915	2804	961	2839	1006	2874	1051	2907	1096	2941	1141			
2600	2704	768	2741	810	2778	855	2813	901	2849	947	2884	993	2918	1039	2952	1085	2986	1129	3019	1173	3051	1217	3083	1259	3115	1300			
2800	2908	941	2943	985	2976	1030	3010	1076	3042	1121	3075	1166	3107	1210	3139	1253	3170	1296	3200	1338	3231	1379	3261	1419	3290	1456			
3000	3110	1111	3142	1156	3173	1201	3205	1245	3236	1289	3267	1332	3296	1373	3325	1414	3354	1455	3382	1496	3412	1536	3439	1573	3465	1609			
Total Air cfm	Total Static Pressure - in. w.g.																												
	1.4		1.5		1.6		1.7		1.8		1.9		2.0		2.1		2.2		2.3		2.4		2.5		2.6		2.7		
	RPM	Watts	RPM	Watts	RPM	Watts	RPM	Watts	RPM	Watts	RPM	Watts	RPM	Watts	RPM	Watts	RPM	Watts	RPM	Watts	RPM	Watts	RPM	Watts	RPM	Watts	RPM	Watts	RPM
800	1805	309	1850	337	1895	366	1940	392	---	---	---	---	---	---	---	---	---	---	---	---	---	---	---	---	---	---	---	---	
1000	1920	380	1962	410	2005	439	2050	466	2094	492	2138	517	2181	541	---	---	---	---	---	---	---	---	---	---	---	---	---	---	
1200	2045	456	2087	484	2130	510	2174	537	2217	563	2260	589	2302	615	---	---	---	---	---	---	---	---	---	---	---	---	---	---	
1400	2182	531	2225	555	2268	581	2310	610	2352	640	2393	671	2433	703	---	---	---	---	---	---	---	---	---	---	---	---	---	---	
1600	2330	616	2371	645	2412	678	2452	713	2491	750	2530	787	2568	824	---	---	---	---	---	---	---	---	---	---	---	---	---	---	
1800	2484	723	2523	765	2561	808	2598	849	2636	890	2672	931	2708	971	---	---	---	---	---	---	---	---	---	---	---	---	---	---	
2000	2641	868	2677	915	2713	961	2749	1003	2784	1044	2819	1084	2853	1124	---	---	---	---	---	---	---	---	---	---	---	---	---	---	
2200	2804	1028	2839	1072	2873	1114	2907	1155	2940	1194	2973	1234	3006	1272	---	---	---	---	---	---	---	---	---	---	---	---	---	---	
2400	2974	1184	3006	1225	3039	1266	3071	1305	3103	1344	3134	1382	3166	1420	---	---	---	---	---	---	---	---	---	---	---	---	---	---	
2600	3146	1340	3177	1379	3207	1417	3238	1456	3269	1494	3299	1532	3329	1569	---	---	---	---	---	---	---	---	---	---	---	---	---	---	
2800	3319	1493	3347	1530	3376	1567	3406	1605	3435	1643	3465	1681	3495	1718	---	---	---	---	---	---	---	---	---	---	---	---	---	---	
3000	3491	1644	3517	1680	3543	1716	3572	1754	3602	1792	3631	1830	3661	1867	---	---	---	---	---	---	---	---	---	---	---	---	---	---	

BLOWER DATA **1.5 HP**

BLOWER TABLE INCLUDES RESISTANCE FOR BASE UNIT ONLY WITH DRY INDOOR COIL AND AIR FILTERS IN PLACE.

FOR ALL UNITS ADD:

- 1 - Any factory installed options air resistance (heat section, economizer, etc.).
- 2 - Any field installed accessories air resistance (duct resistance, diffuser, etc.).

Minimum Air Volume Required For Different Gas Heat Sizes:

Standard Heat - 1075 cfm; Medium Heat - 1150 cfm; High Heat - 1500 cfm

See Page 32 for wet coil and options/accessory air resistance data.

HORIZONTAL

Total Air cfm	Total Static Pressure - in. w.g.																										
	0.1		0.2		0.3		0.4		0.5		0.6		0.7		0.8		0.9		1.0		1.1		1.2		1.3		
	RPM	Watts	RPM	Watts	RPM	Watts	RPM	Watts	RPM	Watts	RPM	Watts	RPM	Watts	RPM	Watts	RPM	Watts	RPM	Watts	RPM	Watts	RPM	Watts	RPM	Watts	RPM
400	708	16	793	37	872	53	957	70	1036	87	1165	104	1294	121	1423	138	1552	155	1681	172	1810	189	1939	206	2068	223	2197
600	835	46	918	65	1000	82	1077	95	1149	107	1221	109	1365	148	1434	154	1497	163	1555	179	1607	200	1656	226	1704	254	1752
800	981	75	1064	92	1144	109	1221	124	1294	139	1365	148	1434	154	1582	207	1638	227	1689	252	1737	279	1783	308	1829	335	1873
1000	1166	105	1241	124	1315	141	1387	159	1454	176	1520	191	1582	246	1739	271	1787	299	1832	330	1876	361	1920	391	1964	419	2007
1200	1374	142	1440	162	1506	182	1569	203	1630	224	1687	246	1687	246	1739	271	1787	299	1832	330	1876	361	1920	391	1964	419	2007
1400	1591	183	1647	209	1701	235	1755	263	1806	291	1854	320	1899	351	1942	382	1984	412	1984	412	2026	442	2068	469	2110	496	2153
1600	1778	258	1827	290	1876	323	1923	355	1970	386	2015	416	2059	444	2102	470	2144	494	2144	494	2185	519	2227	545	2268	572	2309
1800	1973	352	2018	383	2063	415	2107	445	2151	476	2194	504	2237	531	2279	557	2319	584	2319	584	2359	613	2397	645	2435	679	2471
2000	2182	437	2224	468	2265	499	2306	531	2346	563	2385	596	2424	630	2461	666	2496	705	2496	705	2530	745	2564	786	2598	826	2631
2200	2388	540	2426	576	2464	613	2500	651	2536	691	2571	731	2605	774	2637	819	2668	863	2668	863	2700	907	2732	949	2764	990	2795
2400	2589	679	2624	719	2658	761	2691	803	2724	846	2756	890	2786	935	2816	980	2846	1025	2846	1025	2876	1068	2907	1109	2937	1149	2967
2600	2787	845	2819	887	2850	930	2881	973	2911	1017	2941	1060	2970	1104	2999	1147	3028	1189	3028	1189	3057	1230	3087	1270	3117	1310	3147
2800	2983	1021	3013	1063	3042	1106	3070	1149	3099	1191	3127	1234	3156	1277	3184	1320	3212	1363	3212	1363	3241	1404	3271	1445	3301	1486	3331

Total Static Pressure - in. w.g.

Total Air cfm	Total Static Pressure - in. w.g.													
	1.4		1.5		1.6		1.7		1.8		1.9		2.0	
	RPM	Watts	RPM	Watts	RPM	Watts	RPM	Watts	RPM	Watts	RPM	Watts	RPM	Watts
800	708	16	793	37	872	53	957	70	1036	87	1165	104	1294	
1000	835	46	918	65	1000	82	1077	95	1149	107	1221	109	1365	
1200	981	75	1064	92	1144	109	1221	124	1294	139	1365	148	1434	
1400	1166	105	1241	124	1315	141	1387	159	1454	176	1520	191	1582	
1600	1374	142	1440	162	1506	182	1569	203	1630	224	1687	246	1687	
1800	1591	183	1647	209	1701	235	1755	263	1806	291	1854	320	1899	
2000	1778	258	1827	290	1876	323	1923	355	1970	386	2015	416	2059	
2200	1973	352	2018	383	2063	415	2107	445	2151	476	2194	504	2237	
2400	2182	437	2224	468	2265	499	2306	531	2346	563	2385	596	2424	
2600	2388	540	2426	576	2464	613	2500	651	2536	691	2571	731	2605	
2800	2589	679	2624	719	2658	761	2691	803	2724	846	2756	890	2786	

BLOWER DATA

FACTORY INSTALLED OPTIONS/FIELD INSTALLED ACCESSORY AIR RESISTANCE - in. w.g.

Air Volume cfm	Wet Indoor Coil		Humiditrol™+ Reheat Coil	Gas Heating		Economizer	Filters		
	036, 048	060, 074		Medium Heat	High Heat		MERV 8	MERV 13	MERV 16
800	0.01	---	---	0.02	0.02	0.04	0.04	0.05	0.04
1000	0.02	0.02	0.00	0.02	0.02	0.04	0.04	0.07	0.05
1200	0.03	0.04	0.00	0.02	0.02	0.04	0.04	0.07	0.05
1400	0.04	0.05	0.01	0.02	0.03	0.04	0.04	0.07	0.06
1600	0.05	0.07	0.02	0.03	0.04	0.04	0.04	0.07	0.08
1800	0.06	0.08	0.02	0.04	0.05	0.05	0.04	0.07	0.09
2000	0.08	0.10	0.02	0.04	0.06	0.05	0.05	0.08	0.10
2200	---	0.11	0.04	0.04	0.07	0.05	0.05	0.08	0.11
2400	---	0.13	0.04	0.05	0.08	0.05	0.05	0.08	0.12

POWER EXHAUST FAN PERFORMANCE

Return Air System Static Pressure in. w.g.	Air Volume Exhausted cfm
0.00	2000
0.05	1990
0.10	1924
0.15	1810
0.20	1664
0.25	1507
0.30	1350
0.35	1210

BLOWER DATA

CEILING DIFFUSERS AIR RESISTANCE (in. w.g.)

Air Volume cfm	RTD9-65S Step-Down Diffuser			FD9-65S Flush Diffuser	RTD11-95S Step-Down Diffuser			FD11-95S Flush Diffuser
	2 Ends Open	1 Side & 2 Ends Open	All Ends & Sides Open		2 Ends Open	1 Side & 2 Ends Open	All Ends & Sides Open	
800	0.15	0.13	0.11	0.11	---	---	---	---
1000	0.19	0.16	0.14	0.14	---	---	---	---
1200	0.25	0.20	0.17	0.17	---	---	---	---
1400	0.33	0.26	0.20	0.20	---	---	---	---
1600	0.43	0.32	0.20	0.24	---	---	---	---
1800	0.56	0.40	0.30	0.30	0.13	0.11	0.09	0.09
2000	0.73	0.50	0.36	0.36	0.15	0.13	0.11	0.10
2200	0.95	0.63	0.44	0.44	0.18	0.15	0.12	0.12
2400	---	----	---	---	0.21	0.18	0.15	0.14
2600	---	----	---	---	0.24	0.21	0.18	0.17
2800	---	----	---	---	0.27	0.24	0.21	0.20
3000	---	----	---	---	0.32	0.29	0.25	0.25

CEILING DIFFUSER AIR THROW DATA

Air Volume - cfm	¹ Effective Throw - ft.	
	Model	Model
	RTD9-65S	FD9-65S
800	10 - 17	14 - 18
1000	10 - 17	15 - 20
1200	11 - 18	16 - 22
1400	12 - 19	17 - 24
1600	12 - 20	18 - 25
1800	13 - 21	20 - 28
2000	14 - 23	21 - 29
2200	16 - 25	22 - 30
	RTD11-95S	FD11-95S
2600	24 - 29	19 - 24
2800	25 - 30	20 - 28
3000	27 - 33	21 - 29

¹ Effective throw based on terminal velocities of 75 ft. per minute.

ELECTRICAL DATA **3 TON**

Model		LGM036U5E / LGM036U5P		
¹ Voltage - 60Hz		208/230V-3ph	460V-3ph	575V-3ph
Compressor (Inverter)	Rated Load Amps	9.1	5.1	4.1
	Locked Rotor Amps	11	6	12
Outdoor Fan Motor	Full Load Amps (1 ECM)	2.8	1.4	1.1
Power Exhaust (1) 0.33 HP	Full Load Amps	2.4	1.3	1
Service Outlet 115V GFI (amps)		15	15	20
Indoor Blower Motor	Horsepower	1.5	1.5	1.5
	Full Load Amps	4.4	2.3	2.3
² Maximum Overcurrent Protection (MOCP)	Unit Only	25	15	15
	With (1) 0.33 HP Power Exhaust	30	15	15
	Unit Only	19	11	9
³ Minimum Circuit Ampacity (MCA)	Unit Only	19	11	9
	With (1) 0.33 HP Power Exhaust	21	12	10
	Unit Only	19	11	9

NOTE - All units have a minimum Short Circuit Current Rating (SCCR) of 5000 amps.

¹ Extremes of operating range are plus and minus 10% of line voltage.

² HACR type breaker or fuse.

³ Refer to National or Canadian Electrical Code manual to determine wire, fuse and disconnect size requirements.

ELECTRICAL DATA **4 TON**

Model No.		LGM048U5E / LGM048U5P		
¹ Voltage - 60Hz		208/230V-3ph	460V-3ph	575V-3ph
Compressor (Inverter)	Rated Load Amps	13.8	6.5	5.5
	Locked Rotor Amps	17	10	12
Outdoor Fan Motor	Full Load Amps (1 ECM)	2.8	1.4	1.1
Power Exhaust (1) 0.33 HP	Full Load Amps	2.4	1.3	1
Service Outlet 115V GFI (amps)		15	15	20
Indoor Blower Motor	Horsepower	1.5	1.5	1.5
	Full Load Amps	4.4	2.3	2.3
² Maximum Overcurrent Protection (MOCP)	Unit Only	35	15	15
	With (1) 0.33 HP Power Exhaust	40	15	15
	Unit Only	25	12	11
³ Minimum Circuit Ampacity (MCA)	Unit Only	25	12	11
	With (1) 0.33 HP Power Exhaust	27	14	12
	Unit Only	25	12	11

NOTE - All units have a minimum Short Circuit Current Rating (SCCR) of 5000 amps.

¹ Extremes of operating range are plus and minus 10% of line voltage.

² HACR type breaker or fuse.

³ Refer to National or Canadian Electrical Code manual to determine wire, fuse and disconnect size requirements.

ELECTRICAL DATA **5 TON**

Model		LGM060U5E / LGM060U5P		
¹ Voltage - 60Hz		208/230V-3ph	460V-3ph	575V-3ph
Compressor (Inverter)	Rated Load Amps	14.6	7	5.8
	Locked Rotor Amps	21	11	12
Outdoor Fan Motor	Full Load Amps (1 ECM)	2.8	1.4	1.1
Power Exhaust (1) 0.33 HP	Full Load Amps	2.4	1.3	1
Service Outlet 115V GFI (amps)		15	15	20
Indoor Blower Motor	Horsepower	1.5	1.5	1.5
	Full Load Amps	4.4	2.3	2.3
² Maximum Overcurrent Protection (MOCP)	Unit Only	40	15	15
	With (1) 0.33 HP Power Exhaust	40	20	15
³ Minimum Circuit Ampacity (MCA)	Unit Only	26	13	11
	With (1) 0.33 HP Power Exhaust	28	14	12

NOTE - All units have a minimum Short Circuit Current Rating (SCCR) of 5000 amps.

¹ Extremes of operating range are plus and minus 10% of line voltage.

² HACR type breaker or fuse.

³ Refer to National or Canadian Electrical Code manual to determine wire, fuse and disconnect size requirements.

ELECTRICAL DATA **6 TON**

Model		LGM074U5E / LGM074U5P		
¹ Voltage - 60Hz		208/230V-3ph	460V-3ph	575V-3ph
Compressor (Inverter)	Rated Load Amps	16.9	8.3	6.8
	Locked Rotor Amps	21	11	12
Outdoor Fan Motor	Full Load Amps (1 ECM)	2.8	1.4	1.1
Power Exhaust (1) 0.33 HP	Full Load Amps	2.4	1.3	1
Service Outlet 115V GFI (amps)		15	15	20
Indoor Blower Motor	Horsepower	1.5	1.5	1.5
	Full Load Amps	4.4	2.3	2.3
² Maximum Overcurrent Protection (MOCP)	Unit Only	45	20	15
	With (1) 0.33 HP Power Exhaust	45	20	15
³ Minimum Circuit Ampacity (MCA)	Unit Only	29	15	12
	With (1) 0.33 HP Power Exhaust	31	16	13

NOTE - All units have a minimum Short Circuit Current Rating (SCCR) of 5000 amps.

¹ Extremes of operating range are plus and minus 10% of line voltage.

² HACR type breaker or fuse.

³ Refer to National or Canadian Electrical Code manual to determine wire, fuse and disconnect size requirements.

FIELD WIRING NOTES

- For use with copper wiring only
- Field wiring not furnished
- All wiring must conform to NEC or CEC and local electrical codes
- For specific wiring information, please refer to the installation instructions

OUTDOOR SOUND DATA

Size	Octave Band Sound Power Levels dBA, re 10 ⁻¹² Watts Center Frequency - Hz							1,2 Sound Rating Number dBA
	125	250	500	1000	2000	4000	8000	
036	60	65	69	68	63	58	51	73
048	64	67	73	71	66	59	52	76
060	66	69	74	74	68	62	55	78
074	67	72	76	76	70	64	58	80

NOTE - The octave sound power data does not include tonal corrections.

¹ Sound Rating Number according to AHRI Standard 270-2008. Sound Rating Number is the overall A-Weighted Sound Power Level, (LWA), dB (100 Hz to 10,000 Hz).

² Sound Rating Number according to AHRI Standard 370-2011. Sound Rating Number is the overall A-Weighted Sound Power Level, (LWA), dB (100 Hz to 10,000 Hz).

WEIGHT DATA

UNIT

Size	Net		Shipping	
	lbs.	kg	lbs.	kg
036 Base Unit	618	280	678	308
036 Max. Unit	815	370	875	397
048 Base Unit	636	288	696	316
048 Max. Unit	833	378	896	406
060 Base Unit	636	288	696	316
060 Max. Unit	836	379	896	406
074 Base Unit	636	288	696	316
074 Max. Unit	836	379	896	406

FACTORY / FIELD INSTALLED OPTIONS AND ACCESSORIES - NET WEIGHTS

Description	lbs.	kg	
ECONOMIZER / OUTDOOR AIR / EXHAUST			
Economizer			
Economizer, Includes Outdoor Air Hood and Barometric Relief Dampers with Hood	84	38	
Outdoor Air Dampers			
Motorized	40	18	
Manual	30	14	
Power Exhaust			
Standard Static	35	17	
GAS HEAT			
Medium Heat (adder over standard heat)	8	4	
High Heat (adder over standard heat)	19	9	
COMBINATION COIL/HAIL GUARDS			
All models	31	14	
ROOF CURBS			
Hybrid Roof, Downflow			
8 in. height	86	39	
14 in. height	108	49	
18 in. height	125	57	
24 in. height	147	67	
Adjustable Pitch Curb, Downflow			
14 in. height	147	67	
CEILING DIFFUSERS			
Step-Down	RTD9-65S	80	36
	RTD11-95S	118	54
Flush	FD9-65S	80	36
	FD11-95S	118	54
Transitions (Supply and Return)	T1TRAN10AN1	22	10
	T1TRAN20N-1	21	10
HUMIDITROL™+ DEHUMIDIFICATION SYSTEM			
Humiditrol™+ Dehumidification Option	27	12	

UNIT CLEARANCES

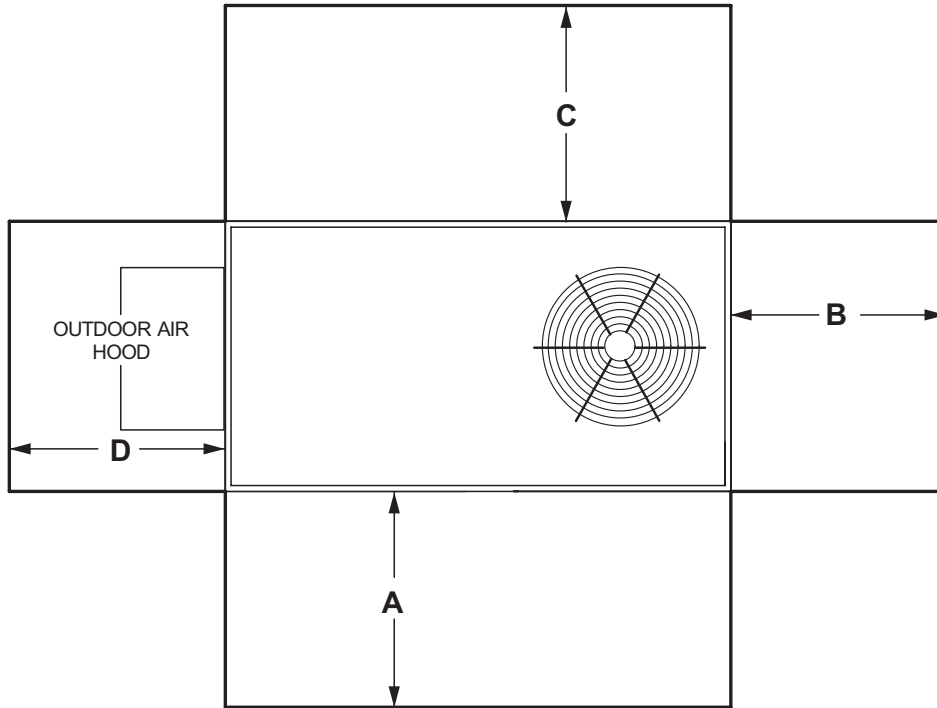

¹ Unit Clearance	A		B		C		D		Top Clearance
	in.	mm	in.	mm	in.	mm	in.	mm	
Service Clearance	48	1219	36	914	36	934	36	914	Unobstructed
Clearance to Combustibles	36	914	1	25	1	25	1	25	
Minimum Operation Clearance	36	914	36	914	36	914	36	914	

NOTE - Entire perimeter of unit base requires support when elevated above the mounting surface.

¹ Service Clearance - Required for removal of serviceable parts.

Clearance to Combustibles - Required clearance to combustible material.

Minimum Operation Clearance - Required clearance for proper unit operation.

DIMENSIONS

UNIT

CORNER WEIGHTS

CENTER OF GRAVITY

Model	AA		BB		CC		DD		EE		FF	
	lbs.	kg	lbs.	kg	lbs.	kg	lbs.	kg	in.	mm	in.	mm
LGM036 Base Unit	131	59	161	73	220	100	179	81	38-1/4	972	19-7/8	505
LGM036 Max. Unit	168	76	207	94	283	128	230	104	39-3/4	1010	19-7/8	505
LGM048 Base Unit	131	59	161	73	220	100	179	81	38-1/4	972	19-7/8	505
LGM048 Max. Unit	169	77	207	94	283	128	230	104	39-3/4	1010	19-7/8	505
LGM060 Base Unit	131	59	161	73	220	100	179	81	38-1/4	972	19-7/8	505
LGM060 Max. Unit	169	77	208	94	284	129	231	105	39-3/4	1010	19-7/8	505
LGM074 Base Unit	131	59	161	73	220	100	179	81	38-1/4	972	19-7/8	505
LGM074 Max. Unit	169	77	208	94	284	129	231	105	39-3/4	1010	19-7/8	505

Base Unit - The unit with NO INTERNAL OPTIONS.

Max. Unit - The unit with ALL INTERNAL OPTIONS Installed. (Economizer, Standard Static Power Exhaust Fans, Controls, etc.). Does not include accessories external to unit or high static power exhaust.

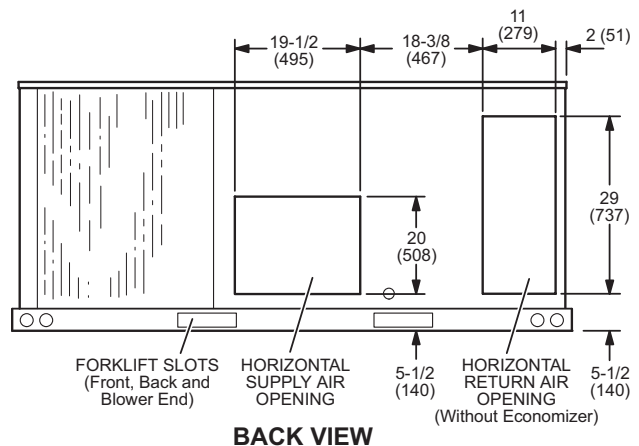
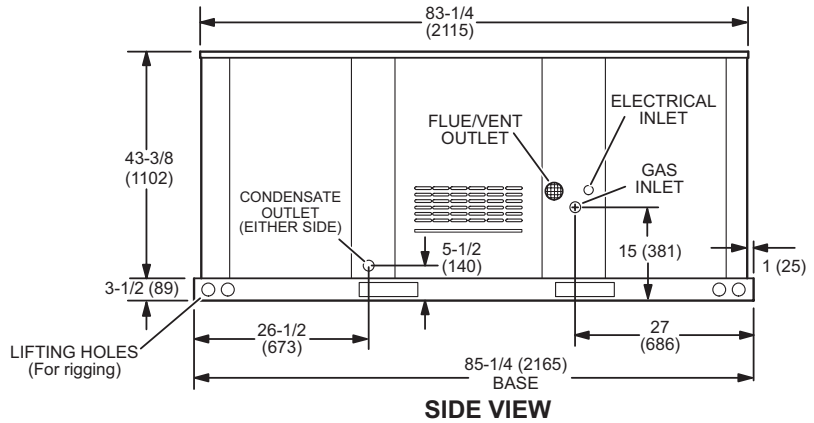
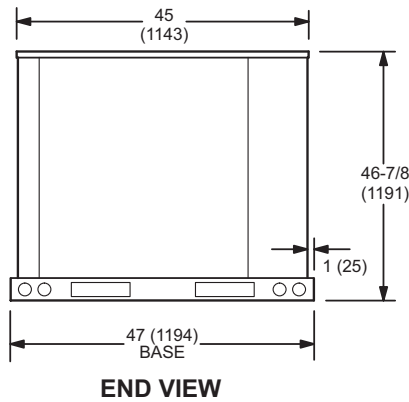
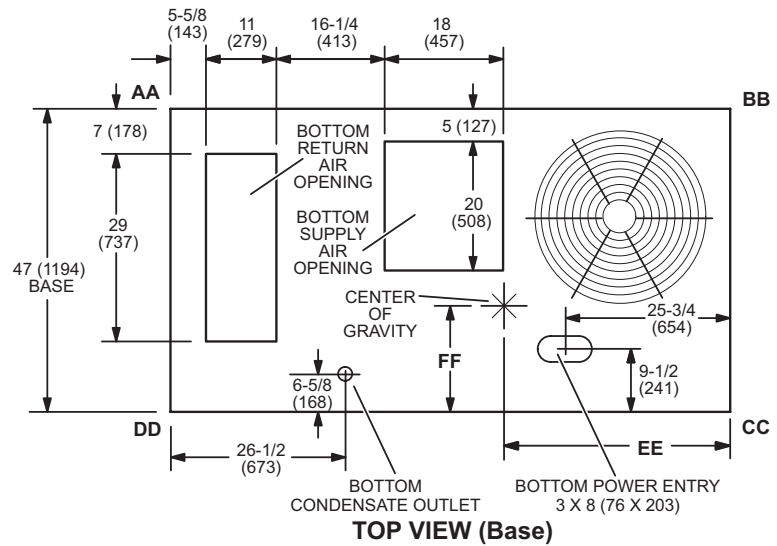

**COMBINATION OUTDOOR AIR HOOD DETAIL FOR OPTIONAL ECONOMIZER AND BAROMETRIC RELIEF DAMPERS
(Furnished With Economizer for Downflow Applications)**

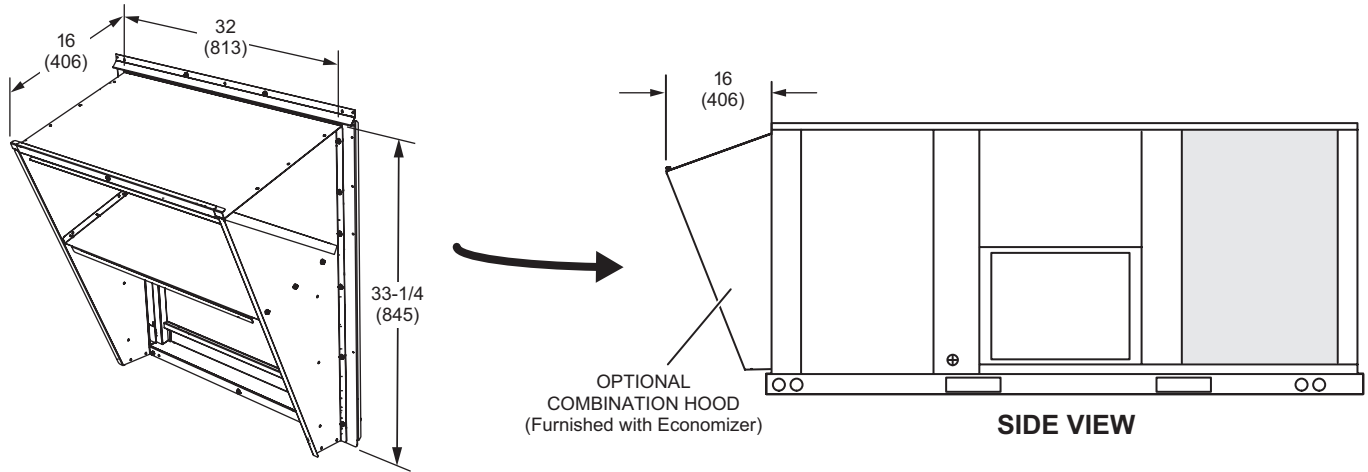

OUTDOOR AIR DAMPER HOOD DETAIL (Downflow or Horizontal Applications)

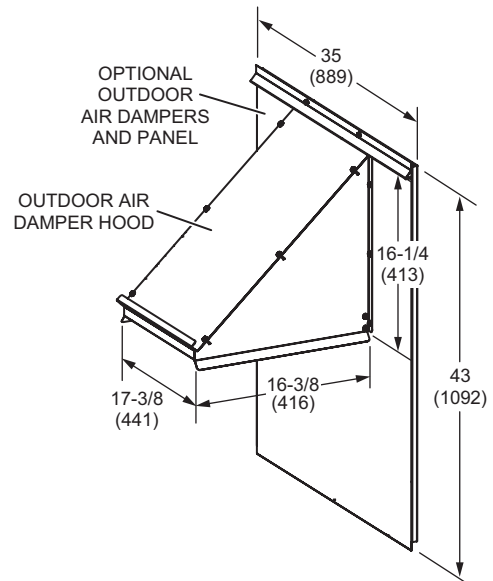
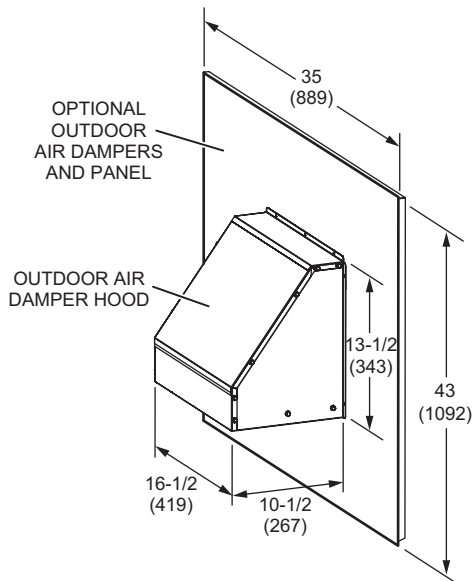
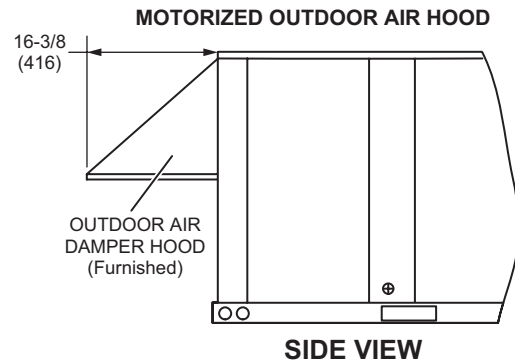
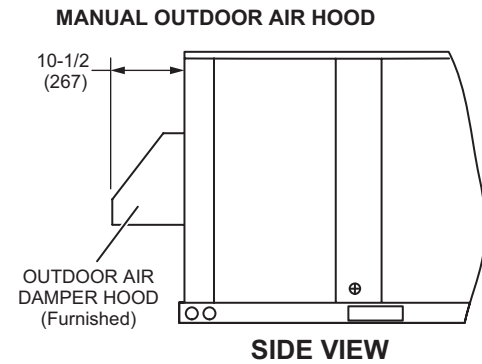

HORIZONTAL ECONOMIZER APPLICATIONS - OUTDOOR AIR HOOD DETAIL WITH OPTIONAL ECONOMIZER DAMPERS AND OPTIONAL HORIZONTAL BAROMETRIC RELIEF DAMPERS AND HOOD

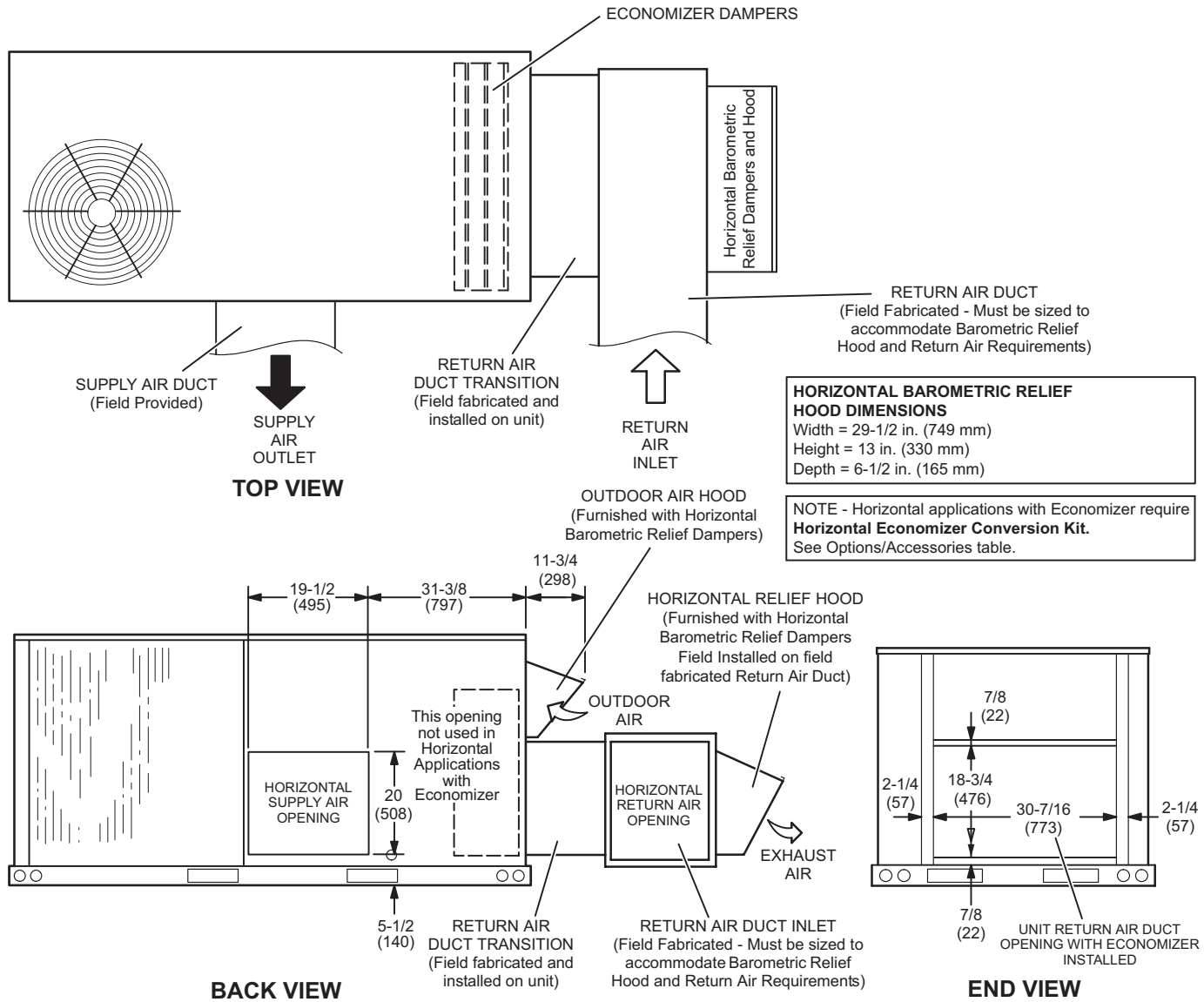

NOTE - Return Air Duct and Transition must be supported.

HYBRID ROOF CURBS - DOUBLE DUCT OPENING

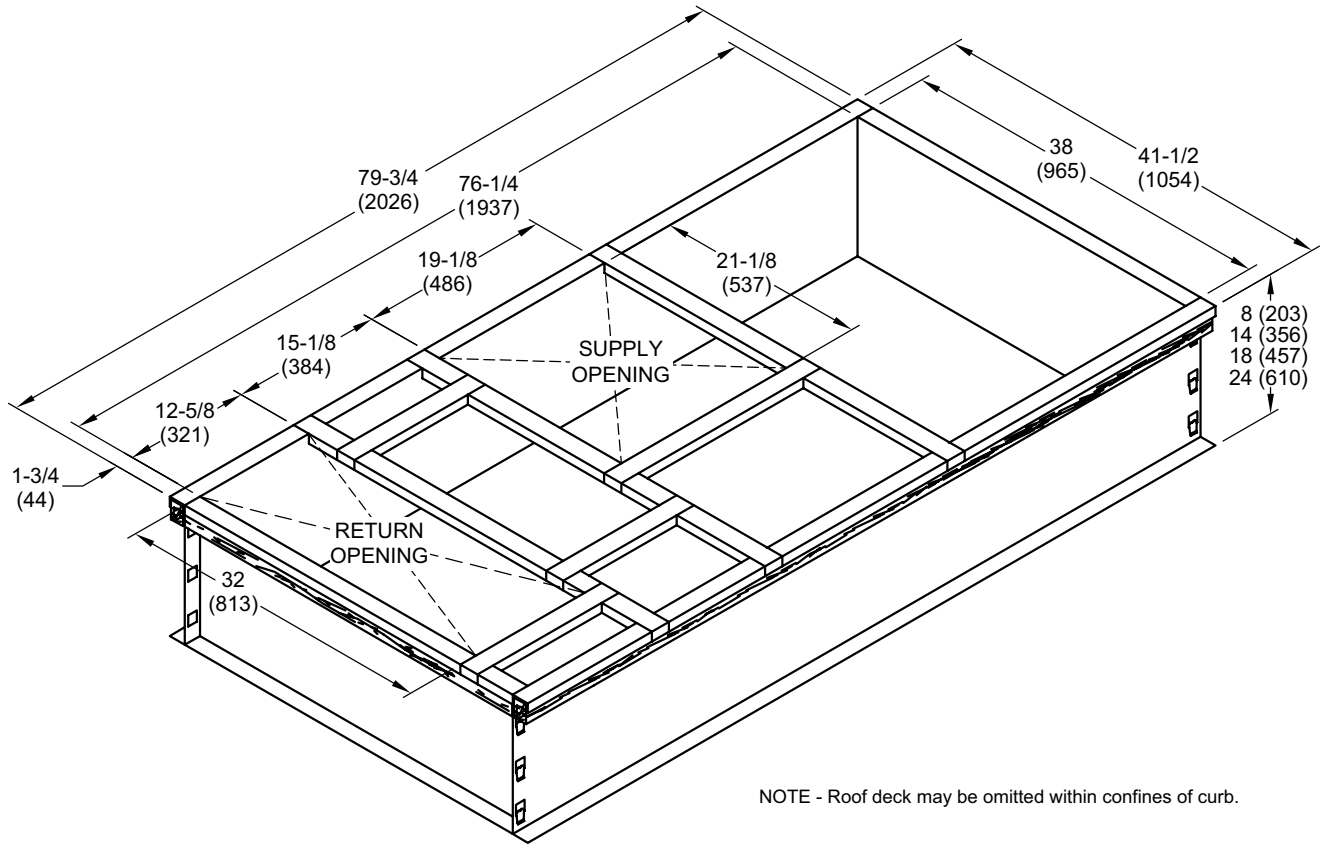

TYPICAL FLASHING DETAIL FOR ROOF CURB

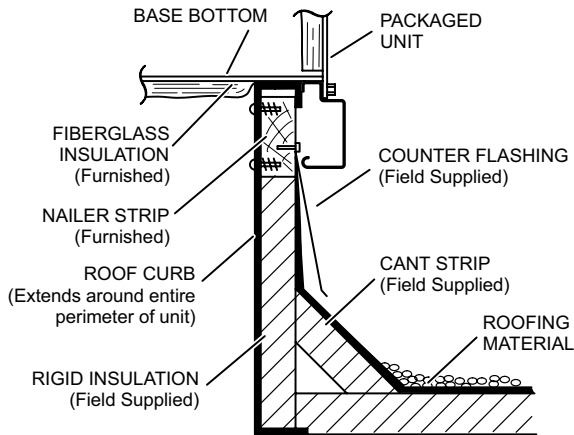

DETAIL ROOF CURB

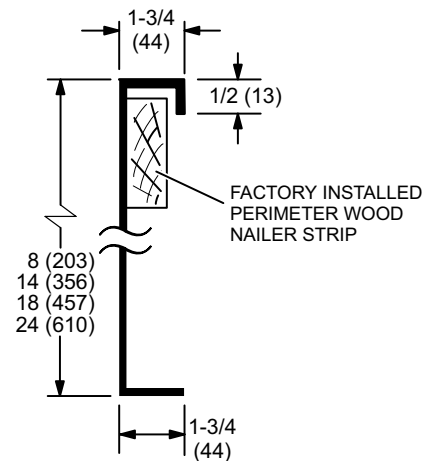

ADJUSTABLE PITCH CURBS - DOUBLE DUCT OPENING

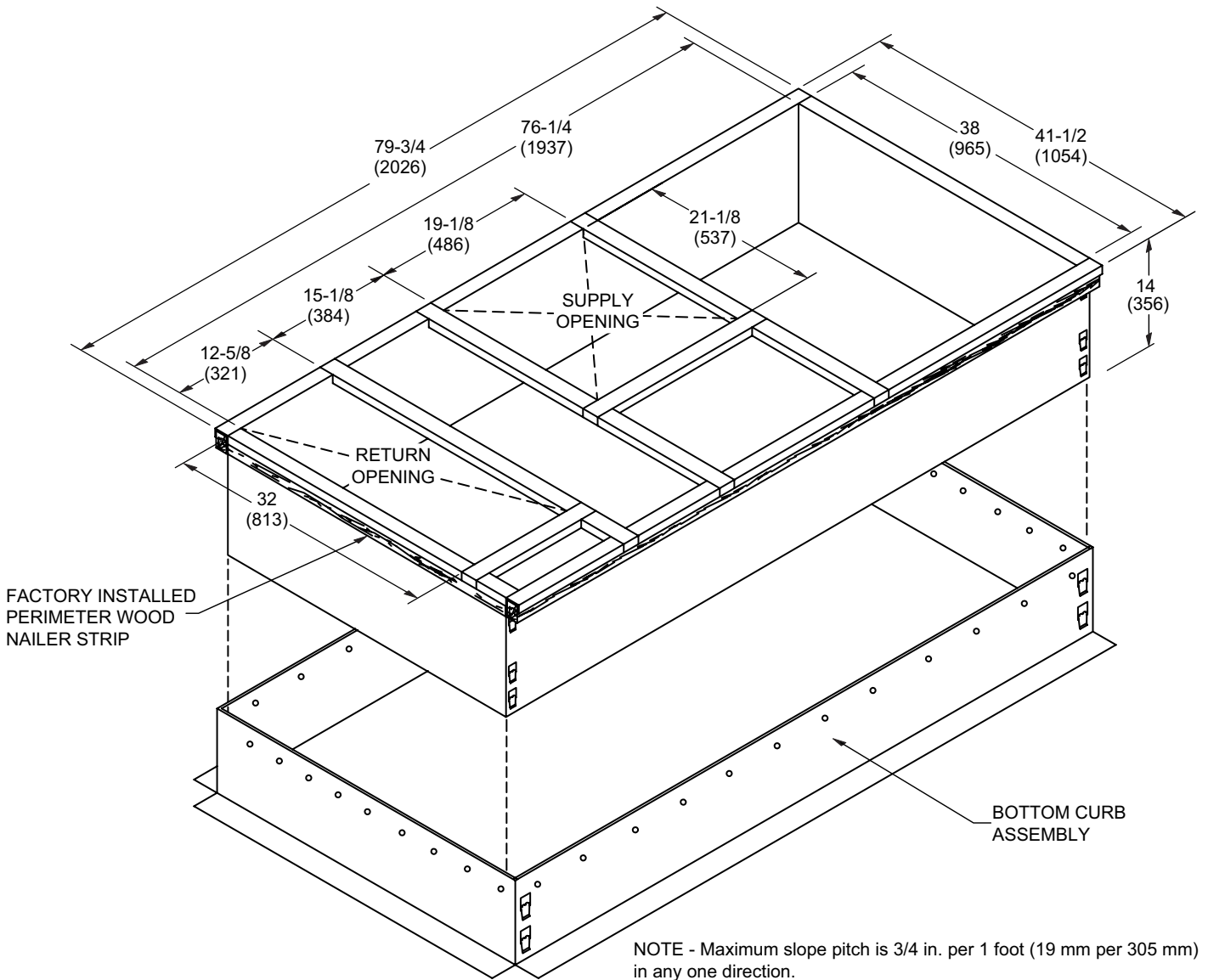

TYPICAL FLASHING DETAIL FOR ROOF CURB

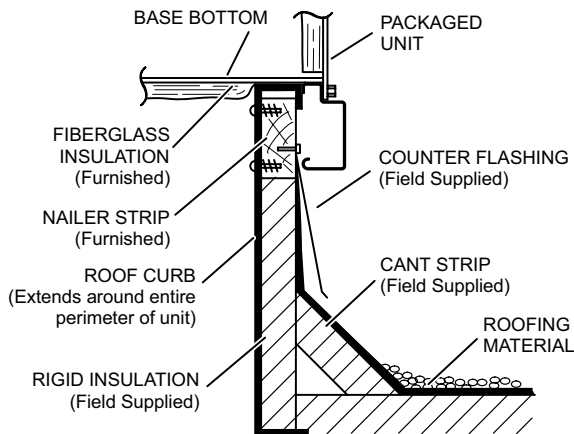

DETAIL ROOF CURB

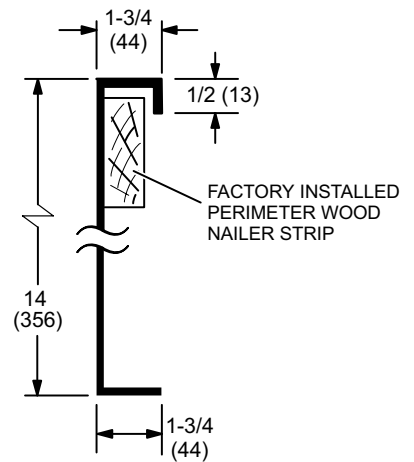

TRANSITIONS

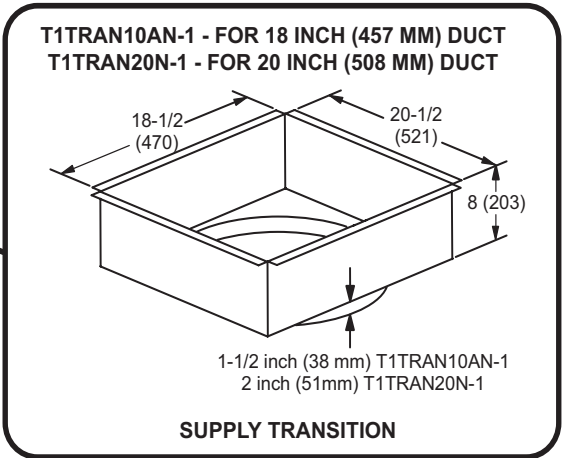
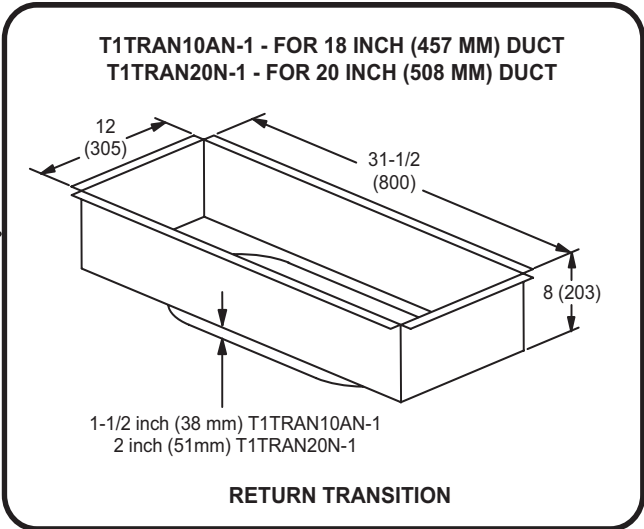
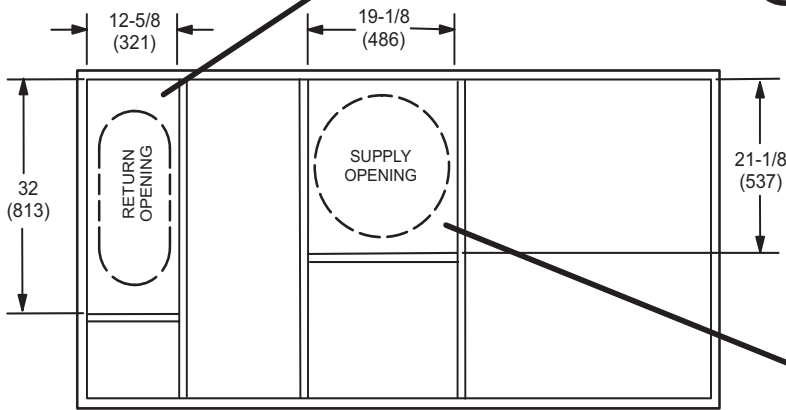

COMBINATION CEILING SUPPLY AND RETURN DIFFUSERS

STEP-DOWN CEILING DIFFUSER

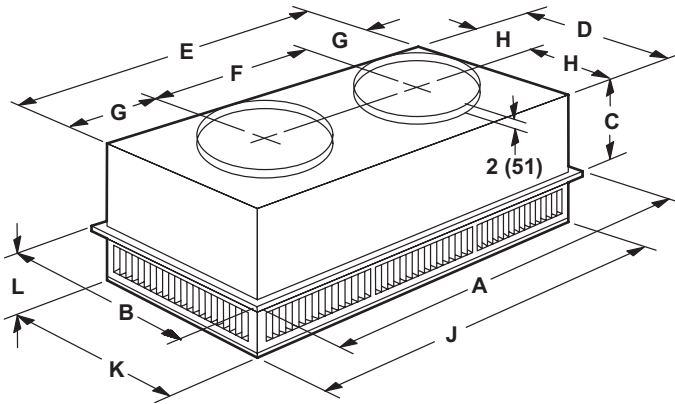

FLUSH CEILING DIFFUSER

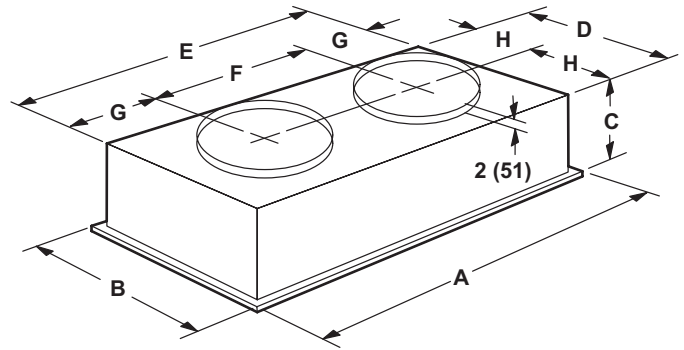

Model		RTD9-65S	RTD11-95S
A	in.	47-5/8	47-5/8
	mm	1159	1159
B	in.	23-5/8	29-5/8
	mm	600	752
C	in.	11-3/8	14-3/8
	mm	289	365
D	in.	21-1/2	27-1/2
	mm	546	699
E	in.	45-1/2	45-1/2
	mm	1156	1158
F	in.	22-1/2	22-1/2
	mm	572	572
G	in.	11-1/2	11-1/2
	mm	292	292
H	in.	10-3/4	13-3/4
	mm	273	349
J	in.	45-1/2	45-1/2
	mm	1156	1156
K	in.	21-1/2	27-1/2
	mm	546	699
L	in.	7-1/8	8-1/8
	mm	181	206
Duct Size	in.	18 round	20 round
	mm	457 round	508 round

Model		FD9-65S	FD11-95S
A	in.	47-5/8	47-5/8
	mm	1159	1159
B	in.	23-5/8	29-5/8
	mm	600	752
C	in.	13-1/2	16-5/8
	mm	343	422
D	in.	21	27
	mm	533	686
E	in.	45	45
	mm	1143	1143
F	in.	22-1/2	22-1/2
	mm	572	572
G	in.	11-1/4	11-1/4
	mm	286	286
H	in.	10-1/2	13-1/2
	mm	267	343
Duct Size	in.	18 round	20 round
	mm	457 round	508 round

REVISIONS

Sections	Description of Change
Options / Accessories	Added RTD9/FD9 Ceiling Diffusers and T1TRAN10AN1 Transition usage
Dimensions	Added dimensions for RTD9/FD9 Ceiling Diffusers
Dimensions	Added dimensions for T1TRAN10AN1 Transition usage



HRAI
✓ MEMBER COMPANY



Intertek

LENNOX

Visit us at www.Lennox.com

For the latest technical information, www.LennoxCommercial.com

Contact us at 1-800-4-LENNOX

NOTE - Due to Lennox' ongoing commitment to quality, Specifications, Ratings and Dimensions subject to change without notice and without incurring liability. Improper installation, adjustment, alteration, service or maintenance can cause property damage or personal injury. Installation and service must be performed by a qualified installer and servicing agency.

©2025 Lennox Industries, Inc.