

PACKAGED UNITS KITS AND ACCESSORIES

507474-02
1/2019
Supersedes 507474-01

BUILDING PRESSURE CONTROL KIT

INSTALLATION INSTRUCTIONS FOR BUILDING PRESSURE CONTROL KIT (13J77; 613720-02) USED ON LGH/LCH 092-360 PACKAGED ROOFTOP UNITS

Shipping and Packing List

Package 1 of 1 contains:

- 1- Static pressure transducer (A34)
- 1- Outdoor static pressure assembly

Bag assembly containing:

- 1-Wiring diagram
- 6-#10 Screws
- 1-Wire tie

Application

Based on input from the Building Pressure Control Kit, the Unit Control modulates dampers to maintain a constant building pressure.

Rooftop unit must be equipped with an economizer and an A55 Unit Controller.

The A34 pressure transducer senses the difference between the outdoor and indoor (building) air pressure and is wired to the Unit Controller.

Installation

- 1- Disconnect power to unit.
- 2- Open filter or compressor access panel.
- 3- Install the A34 sensor as shown in figures 1 or 2 for 092-152 units and figure 3 for 156-360 units. Secure sensor with two #10 self drilling screws.
- 4- Remove the A34 sensor cover and connect field-provided three-wire cable (22AWG) as shown in figure 4. Use an approximately 4-foot length of cable for 092-152 units and 10-foot length of cable for 156-360 units.
- 5- Set the A34 control DIP switches to a pressure range of -0.5 to 0.5" w.c. and 0-10VDC output. Refer to manufacturer's documentation for details.
- 6- Route the other end of three-wire cable to the A55 Unit Controller J298. See s 1 or 2 for 092-152 units and 3 for 156-360 units.
- 7- Bundle excess wiring and secure with wire tie. Replace A34 control cover.

8- Attach outdoor air tubing to the A34 control (-) port and the indoor air (building) tubing to the (+) port. Drill ¼" holes and route air tubing as shown in figures 1 or 2 for 092-152 units and figure 3 for 156-360 units.

9- Connect the other end of the outdoor air tubing to the outdoor static pressure assembly. See figure 5.

⚠ WARNING

Improper installation, adjustment, alteration, service or maintenance can cause property damage, personal injury or loss of life. Installation and service must be performed by a licensed professional HVAC installer or equivalent, service agency, or the gas supplier

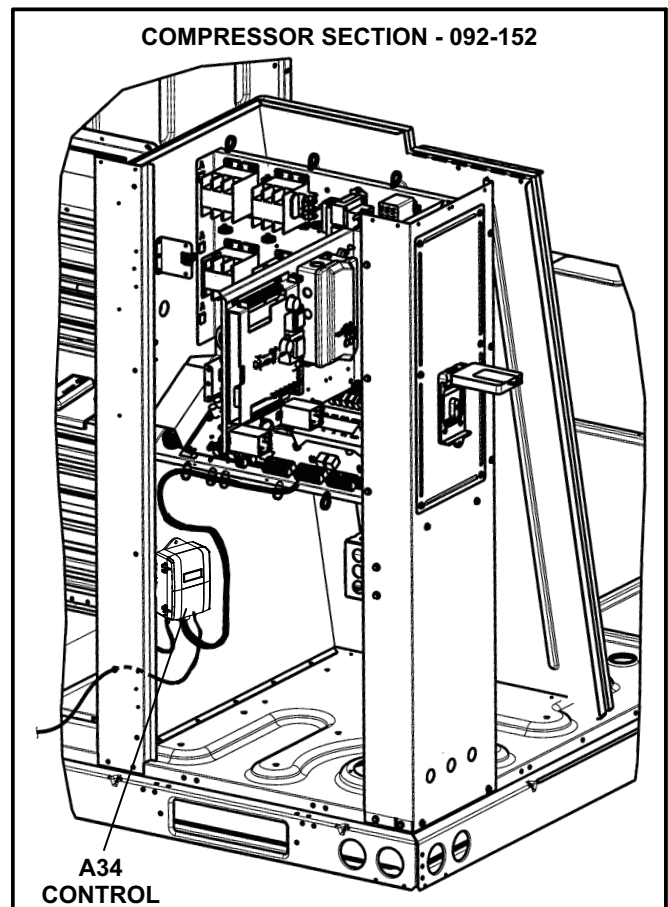

FIGURE 1

CONTROL INSTALLATION - 092-152 UNITS

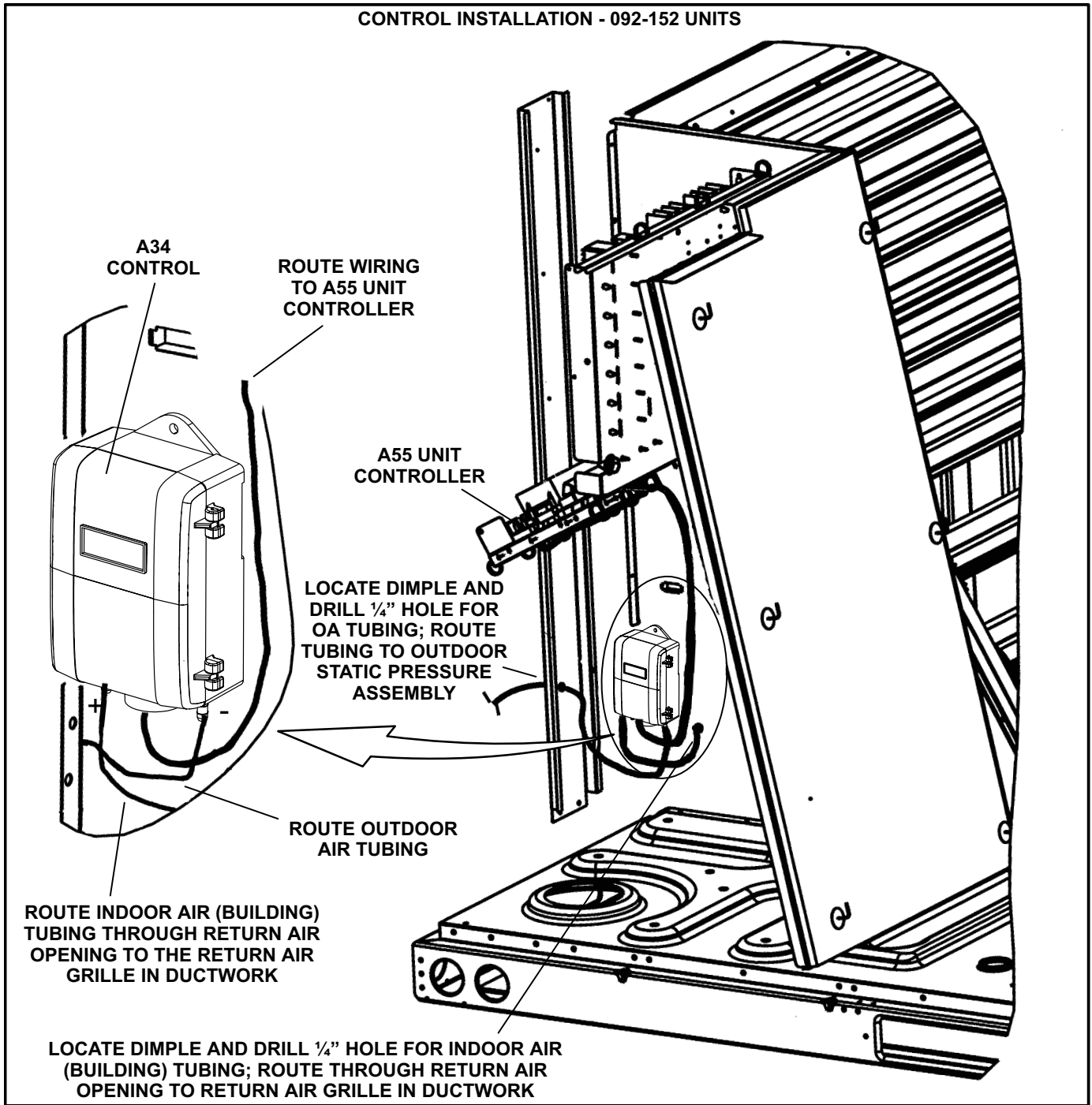

FIGURE 2

⚠ CAUTION

As with any mechanical equipment, contact with sharp sheet metal edges can result in personal injury. Take care while handling this equipment and wear gloves and protective clothing.

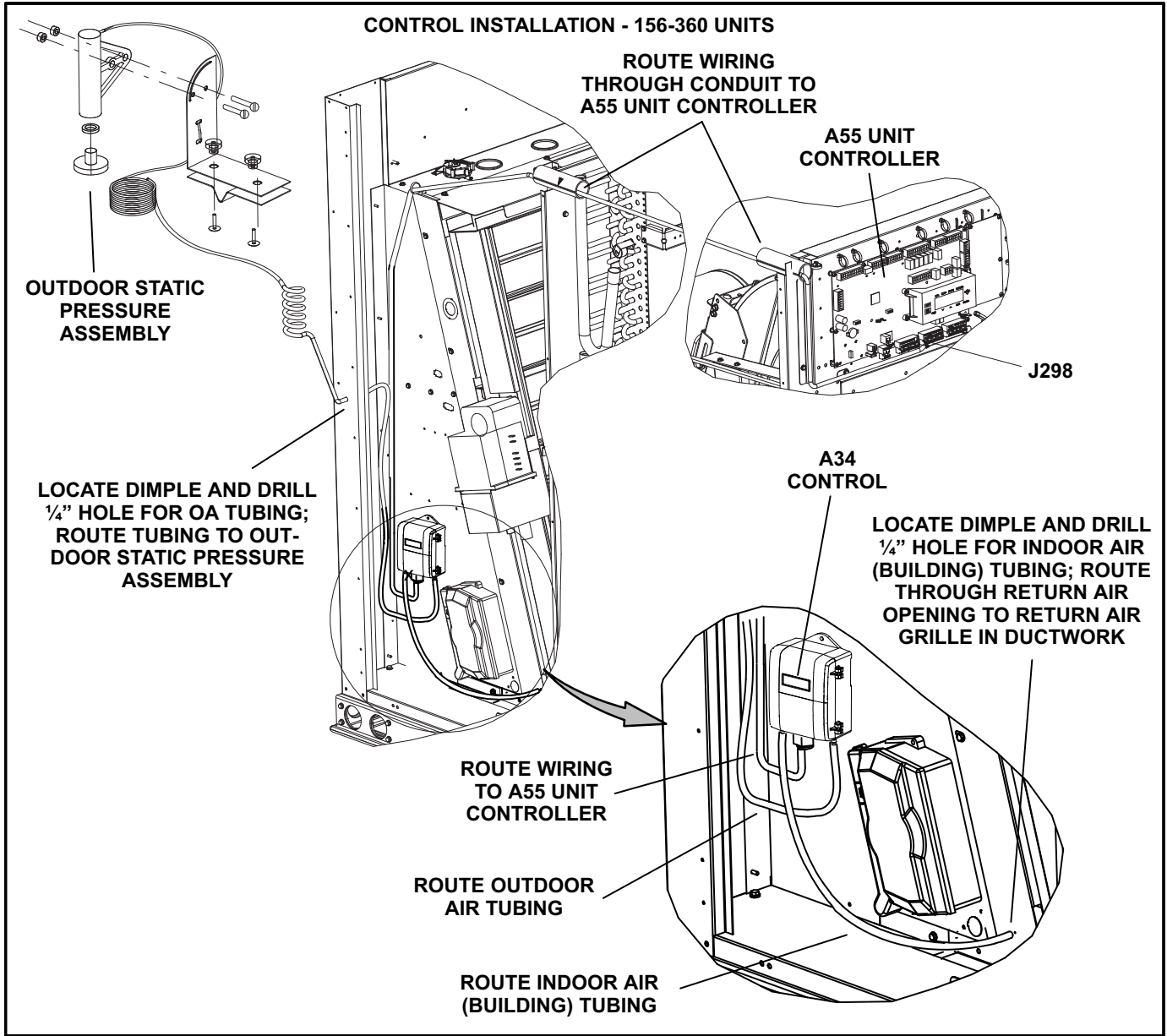

FIGURE 3

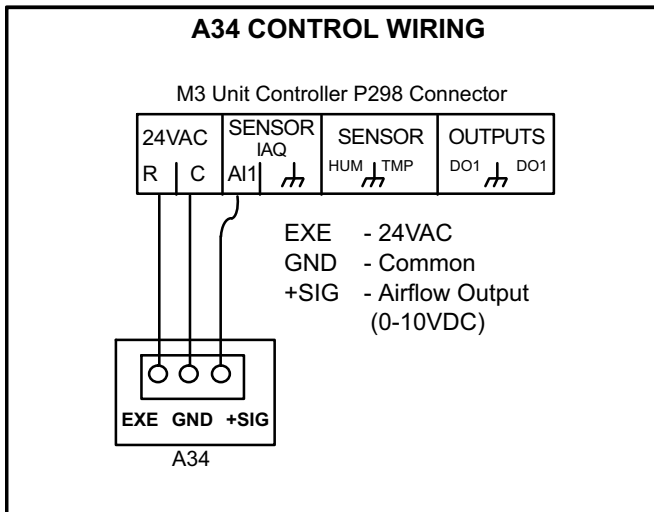

FIGURE 4

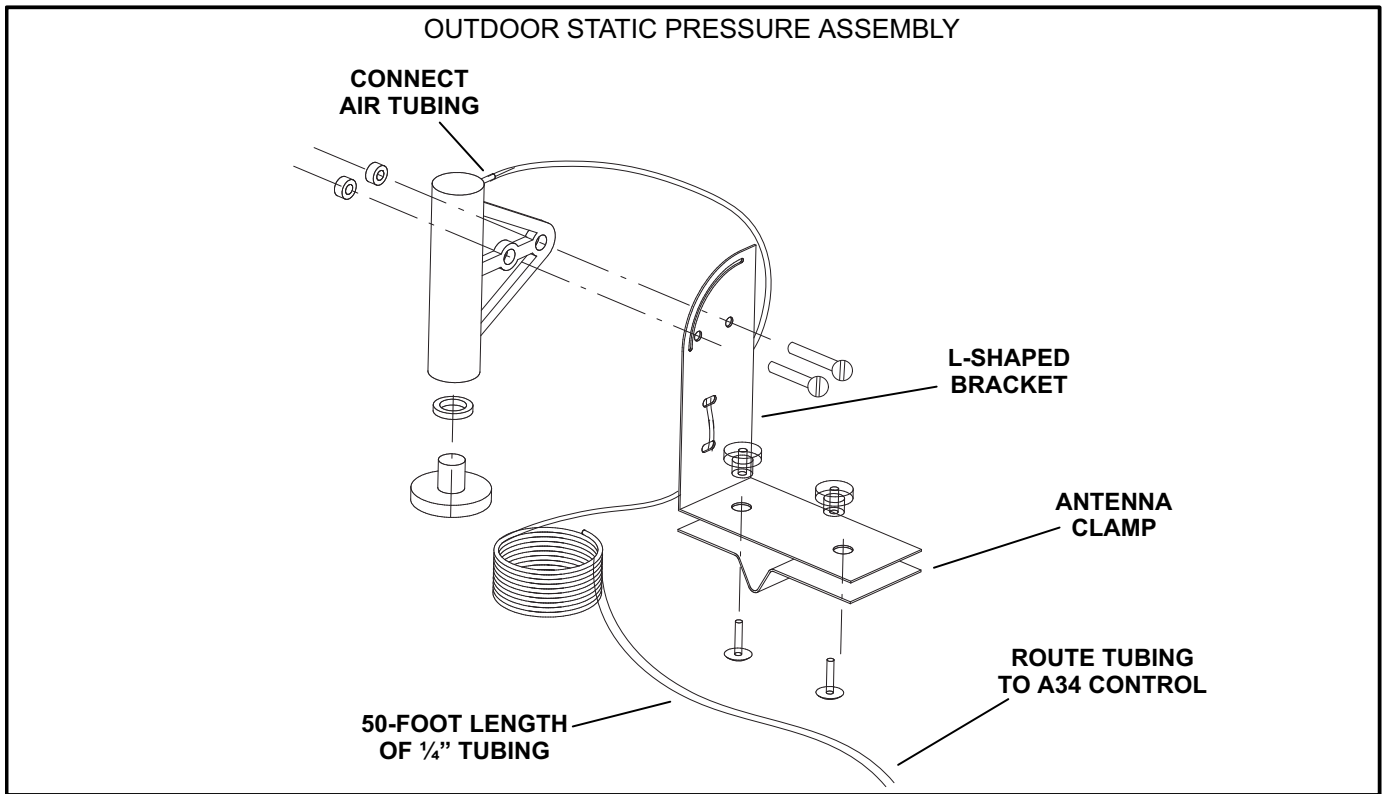

FIGURE 5

Outdoor Static Pressure Assembly

Keep the following in mind when installing the outdoor air static pressure assembly:

- The most important factor when selecting an installation location is existing obstructions. Trees, chimneys, signs and buildings all cause turbulence which may result in abnormal, inaccurate static pressure readings. The sensor should be positioned as far from these sources of turbulence as possible.
- Choose a location minimizing the length of tubing run on the roof.
- If available, an existing structure such as a radio antenna mast can be used to install the sensor. Alternatively, the "L" shaped bracket can be attached directly to any rooftop unit. Secure sensor with two #10 screws provided.

Parameter Settings

To enable the building pressure control, use the following Unit Controller menu:

SETUP > TEST & BALANCE > DAMPER

Navigate to DAMPER CONTROL / VENTILATION OPTIONS. Select BLDNG PRESS CTRL and press SAVE.

Enter the PRESSURE SETPOINT in " w.c. Press SAVE.

<u>Parameter</u>	<u>Default Setting</u>
328	100
329	30