

LGT

ENLIGHT ROOFTOP UNITS

High Efficiency | Lennox® CORE Controller | Environ™ Coil | **R-454B** | 60Hz

COMMERCIAL
PRODUCT SPECIFICATIONS (EHB)



25 to 30 Tons

Net Cooling Capacity - 298,000 to 348,000 Btuh
Gas Input Heat Capacity - 260,000 to 480,000 Btuh

ENLIGHT



SMARTWIRE™ SYSTEM



MODEL NUMBER IDENTIFICATION

LGT302H5VS1Y

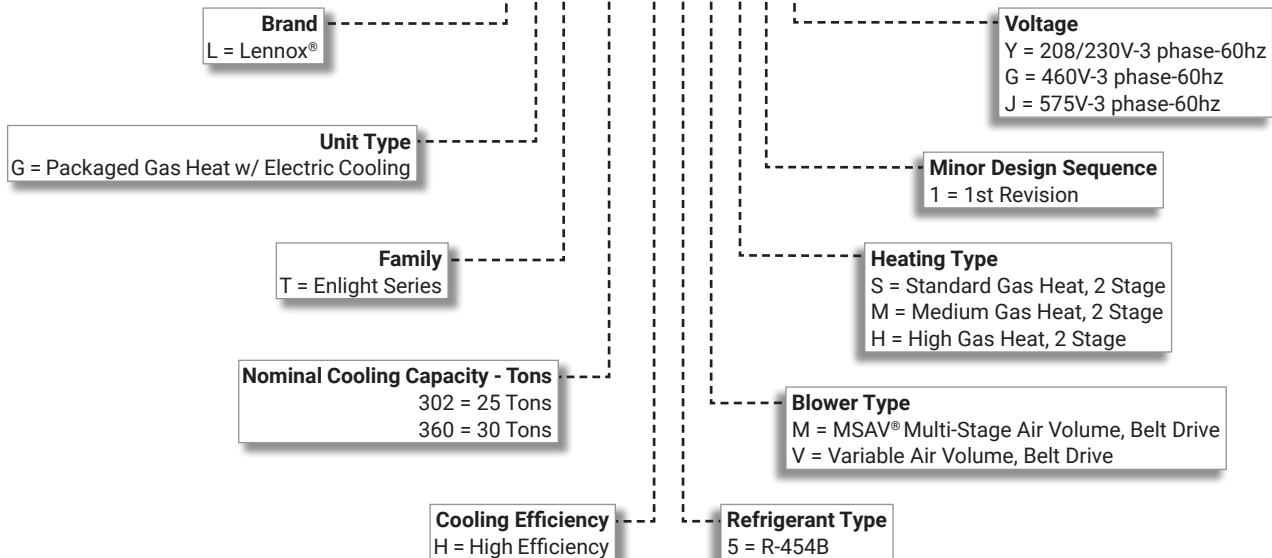

FEATURE HIGHLIGHTS

Enlight rooftop units featuring the Lennox® CORE Control System create a bright future through a highly energy-efficient and environmentally sustainable design. Comprehensive configurations meet a wide range of applications, making it the most flexible product line Lennox has to offer.

1. Heat Exchanger/Inshot Burners
2. Scroll Compressors
3. Environ™ Coil System
4. Thermal Expansion Valves
5. Filters/Driers
6. Outdoor Coil Fan Motors
7. Heavy Gauge Steel Cabinet
8. Hinged Access Panels
9. Variable or MSAV® Multi-Stage Air Volume Blower
10. Air Filters
11. Lennox® CORE Control System
12. Economizer (option)
13. Downflow Barometric Relief Dampers (option)
14. Power Exhaust (option)
15. Humiditrol® Dehumidification (option)

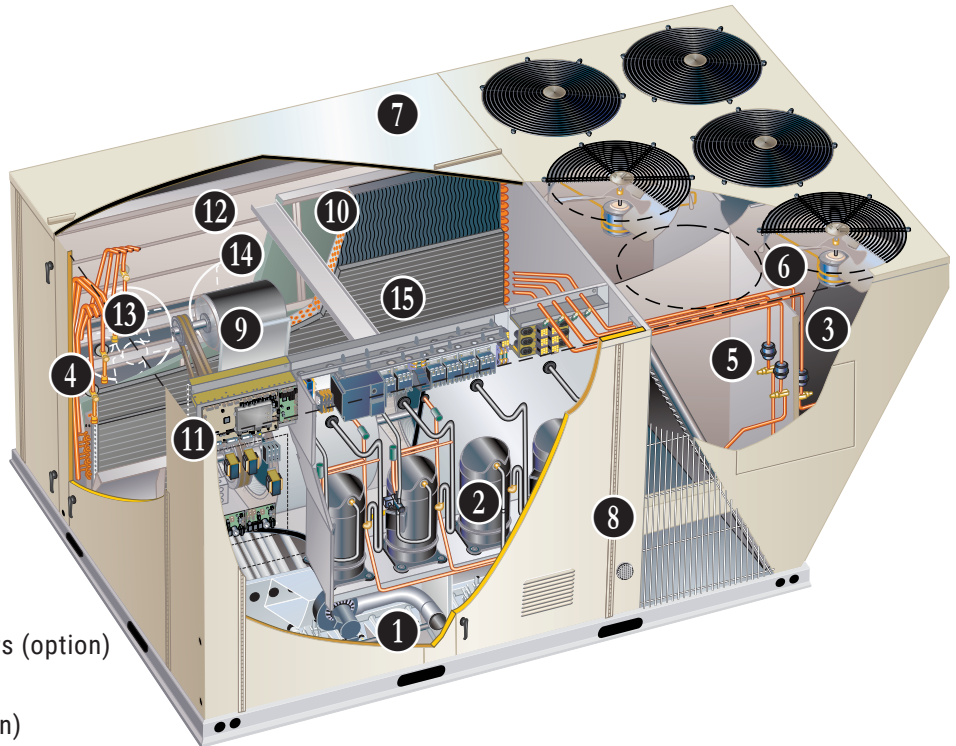

CONTENTS

Approvals And Warranty	3
Blower Data	34
Control System	9
Dimensions - Accessories	44
Dimensions - Unit	43
Electrical Accessories	38
Electrical Data	38
Features And Benefits	3
High Altitude Derate	29
Humiditrol® Dehumidification System Option	14
Humiditrol® Dehumidification System Ratings	33
Model Number Identification	1
Optional Conventional Temperature Control Systems	16
Options / Accessories	23
Outdoor Sound Data	41
Specifications	27
- 25 Ton	27
- 30 Ton	28
- Gas Heat	29
Unit Clearances	40
Weight Data	42

APPROVALS AND WARRANTY

APPROVALS

- Tested at conditions included in AHRI Standard 340/360-2023
- ETL and CSA listed
- Unit and components ETL, NEC and CEC bonded for grounding to meet safety standards for servicing
- All models are ASHRAE 90.1 energy efficiency compliant and meet or exceed requirements of Section 6.8
- All models meet DOE 2023 energy efficiency standards and UL 60335-2-40 Refrigerant Detector Requirements
- MSAV® Multi-Stage Air Volume models meet California Code of Regulations, Title 24 and ASHRAE 90.1 Section 6.4.3.10 requirements for staged airflow
- ISO 9001 Registered Manufacturing Quality System

WARRANTY

- Aluminized Heat Exchanger - Limited ten years
- Stainless Steel Heat Exchanger (optional) - Limited fifteen years
- Compressors - Limited five years
- Environ™ Coil System - Limited three years
- Lennox® CORE Unit Controller - Limited three years
- Variable-Frequency Drive (VFD) - Limited five years
- High Performance Economizers (optional) - Limited five years
- All other covered components - Limited one year

FEATURES AND BENEFITS

HEATING SYSTEM

1 Heat Exchanger

- Tubular construction, aluminized steel
- Life-cycle tested

NOTE - Optional Stainless Steel Heat Exchanger is required if mixed air temperature is below 45°F.

2

- Aluminized steel inshot burners
- Direct spark ignition
- Electronic flame sensor
- Combustion air inducer
- Redundant automatic dual stage gas valve with manual shut-off

Electronic Pilot Ignition

- Electronic spark igniter provides positive direct ignition of burners on each operating cycle
- Permits main gas valve to stay open only when the burners are proven to be lit
- If loss of flame occurs, gas valve closes, shutting off the gas to the burners
- LED indicates status and aids in troubleshooting
- Factory installed in the control section

Limit Controls

- Redundant limit controls with fixed temperature setting
- Protects heat exchanger and other components from overheating

Safety Switches

- Flame roll-out switch
- Flame sensor

- Combustion air inducer proving switch
- Protects system operation

Required Selections

Gas Input Choice - Order one:

- Standard Gas Heat, 2 Stage (169,000/260,000 Btuh)
- Medium Gas Heat, 2 Stage (234,000/360,000 Btuh)
- High Gas Heat, 2 Stage (312,000/480,000 Btuh)

NOTE – Two-stage heat models can be operated with four stages of gas heating when controlled in either zone sensor, Discharge Air Control, or fresh air tempering mode on the Lennox® CORE unit controller (available when using the CS8500 thermostat or when connected to Building Automation Systems using BACnet, LonTalk, or S-Bus protocols). See Gas Heating Specifications table.

Options/Accessories

Factory Installed

Stainless Steel Heat Exchanger

- Required if mixed air temperature is below 45°F

Field Installed

Low Temperature Vestibule Heater

- Electric heater automatically controls minimum temperature in gas burner compartment when temperature is below -40°F
- CSA certified to allow operation of unit down to -60°F

FEATURES AND BENEFITS

HEATING SYSTEM (continued)

Field Installed

Combustion Air Intake Extensions

- Recommended for use with existing flue extension kits in areas where high snow areas can block intake air
- Order two kits

LPG/Propane Kits

- Conversion kit to field change over units from Natural Gas to LPG/Propane
- Order two kits

Vertical Vent Extension Kit

- Use to exhaust flue gases vertically above unit
- Required when unit vent is too close to fresh air intakes per building codes
- Also prevents ice formation on intake louvers
- Kit contains vent transition, vent tee, drain cap and installation hardware
- Order two kits.

NOTE - Straight vent pipes (4 in. B-Vent) and caps are not furnished and must be field supplied. Refer to kit instructions for additional information.

COOLING SYSTEM

- Designed to maximize sensible and latent cooling performance at design conditions
- System can operate from 0°F to 125°F without any additional controls

R-454B Refrigerant

- Low GWP (Global Warming Potential)
- Zero ODP (Ozone Depletion Potential)
- Low Toxicity/Lower Flammability - A2L
- Unit is factory pre-charged

3 Scroll Compressors

- Scroll compressors on all models for high performance, reliability and quiet operation
- Resiliently mounted on rubber grommets for quiet operation

Compressor Crankcase Heaters

- Protects against refrigerant migration that can occur during low ambient operation or during extended off cycles

4 Condenser Coil - Environ™ Coil System

- Lightweight, all aluminum brazed fin construction
- Constructed of three components
 - A flat extrusion tube
 - Fins in-between the flat extrusion tube
 - Two refrigerant manifolds

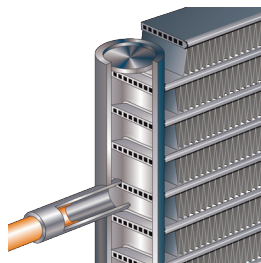

Environ™ Coil System Features:

- Improved heat transfer performance due to high primary surface area (flat tubes) versus secondary surface (fins)
- Smaller internal volume (reduced refrigerant charge)

- High durability
- All aluminum construction
- Fewer brazed joints
- Compact design
- Reduced unit weight
- Easy maintenance/cleaning
- Mounting brackets with rubber inserts secure coil to unit providing vibration dampening and corrosion protection
- Angled cabinet design protects coil from damage

Evaporator Coil

- Copper tube construction
- Enhanced rippled-edge aluminum fins
- Flared shoulder tubing connections
- Silver soldered construction
- Factory leak tested
- Cross-row circuiting with rifled tubing

5 Thermal Expansion Valves

- Ensures optimal performance throughout the application range
- Removable element head

6 Filter/Driers

- High capacity filter/drier protects the system from dirt and moisture

High Pressure Switches

Protects the compressor from overload conditions such as dirty condenser coils, blocked refrigerant flow or loss of outdoor fan operation

Low Pressure Switches

- Protects the compressors from low pressure conditions such as low refrigerant charge or low/no airflow

Antimicrobial Condensate Drain Pan

- Composite pan, sloped to meet drainage requirements per ASHRAE 62.1
- Antimicrobial additive prevents growth of mold and mildew, which improves indoor air quality and reduces drain line blockage
- Side drain connections

NOTE - Stainless steel drain pan available as a factory installed option.

Indoor Coil Freeze Protection

- Protects the evaporator coil from damaging ice build-up due to conditions such as low/no airflow or low refrigerant charge

FEATURES AND BENEFITS

COOLING SYSTEM (Continued)

- 7 Outdoor Coil Fan Motors**
- Thermal overload protected
 - Totally enclosed
 - Permanently lubricated ball bearings
 - Shaft up
 - Wire basket mount

Outdoor Coil Fans

- PVC coated fan guard furnished

Required Selections

Cooling Capacity

- Specify nominal cooling capacity

Options/Accessories

Factory or Field Installed

Drain Pan Overflow Switch

- Monitors condensate level in drain pan
- Shuts down unit if drain becomes clogged

Stainless Steel Drain Pan

- Non-corrosive drain pan

Field Installed

Condensate Drain Trap

- Available in copper or PVC

LOW GWP REFRIGERANT DETECTION SYSTEM (RDS)

- Complies with UL 60335-2-40 approved standard
- Required for all systems using R-454B refrigerant
- Factory installed on all units
- Consists of a refrigerant detection sensor(s) and a mitigation control
- Ensures safe operation for systems equipped with R-454B refrigerant
- Sensor(s) monitors indoor coil area for R-454B refrigerant
- If R-454B refrigerant is detected the refrigerant detection system will prevent compressor and heating operation until R-454B refrigerant is no longer detected
- Refrigeration detection system energizes blower if any R-454B refrigerant is detected to mitigate any concentrations of refrigerant from the unit and the system

CABINET

8 Construction

- Heavy-gauge steel panels
- Full perimeter heavy-gauge galvanized steel base rail
- Base rails have rigging holes
- Three sides of the base rail have forklift slots
- Raised edges around duct and power entry openings in the bottom of the unit for water protection

Airflow Choice

- Units are shipped in downflow (vertical) return air flow configuration

NOTE - Units can be field converted to horizontal air flow with optional Horizontal Return Air Panel Kit and Horizontal Roof Curb.

Power/Gas Entry

- Electrical and gas lines can be routed through the unit base or through horizontal access knock-outs

Exterior Panels

- Constructed of heavy-gauge, galvanized steel
- Textured pre-paint with polyurethane finish
- Cyclic salt fog and UV exposure up to 1,680 hours per ASTM D5894

Insulation

- Fully insulated with non-hygroscopic fiberglass insulation (conditioned areas)
- Unit base is fully insulated
- Base insulation serves as an air seal to the roof curb, eliminating the need to add a seal during installation

9 Hinged Access Panels

- Filter section
- Blower section
- Heating section
- Compressor/controls section
- Panel seals and quarter-turn latching handles provide a tight air and water seal

Options/Accessories

Factory Installed

Corrosion Protection

- Completely flexible immersed coating
- Electrodeposited dry film process (AST ElectroFin E-Coat)
- ASTM B117 / DIN 53167 Salt Spray - 15,000+ hours
- ASTM G85 Annex A3 SWAAT Modified Salt Spray - 3000 hours
- VA Master Construction Specification Division 23 for High Humidity Installations
- CID AA-52474A (GSA)
- Indoor Corrosion Protection:
 - Coated coil
 - Coated reheat coil
 - Painted blower housing

FEATURES AND BENEFITS

CABINET (continued)

- Painted base
- Outdoor Corrosion Protection:
 - Coated coil
 - Painted outdoor base

Factory or Field Installed

Combination Coil/Hail Guards

- Heavy gauge steel frame
- Painted to match cabinet
- Expanded metal mesh protects outdoor coil

Field Installed

Horizontal Return Air Panel Kit

- Required for horizontal applications with Horizontal Roof Curb
- Contains panel with return air opening for field replacement of existing unit panel and panel to cover bottom return air opening in unit
- See dimension drawings.

BLOWER

- A wide selection of supply air blower options are available to meet a variety of airflow requirements

Motor

- Overload protected
- Ball bearings
- Belt drive motors are offered on all models and are available in several different sizes to maximize air performance

NOTE - All blower motors 5 HP and above meet minimum energy efficiency standards in accordance with the Energy Independence and Security Act (EISA) of 2007

10 Supply Air Blower

- Forward curved blades
- Double inlet
- Blower wheel statically and dynamically balanced
- Ball bearings
- Adjustable pulley (allows speed change)
- Blower assembly slides out of unit for servicing
- Grease fittings furnished

Blower Proving Switch

- Monitors blower operation, shuts down unit if blower fails

Supply Static Pressure Transducer (VAV Models Only)

- Sends information to the Lennox® CORE unit controller to control VFD blower speed
- Shipped with the unit for remote field installation in the supply duct

Required Selections

Select VAV Variable Air Volume or MSAV® Multi-Stage Air Volume

- Variable Air Volume (VAV) variable frequency drive (VFD) varies the air volume to maintain a constant duct static pressure
- MSAV Multi-Stage Air Volume models stage the amount of airflow according to compressor stages, heating demand, ventilation demand or smoke alarm
 - Utilizes a Variable Frequency Drive (VFD) to stage the supply air blower airflow
 - VFD alters the frequency and voltage of the power supply to the blower to control blower speed
- The amount of airflow for each stage can be set according to a parameter in the Lennox® CORE Unit Controller
 - Unit is shipped from the factory with preset airflows
 - The MSAV® Multi-Stage Air Volume supply air blower option can be ordered with or without an Electronic Bypass Control
 - If equipped with the bypass control the MSAV® Multi-Stage Air Volume features automatic electronic bypass control of the VFD
 - In case of a VFD malfunction, a VFD alarm is generated by the Lennox® CORE Unit controller
 - Unit controller will automatically switch to full blower speed if a VFD alarm is generated

NOTE - Units equipped a Variable Frequency Drive (VFD) are designed to operate on balanced, three-phase power. Operating units on unbalanced three-phase power will reduce the reliability of all electrical components in the unit. Unbalanced power is a result of the power delivery system supplied by the local utility company. Factory-installed inverters are sized to drive blower motors with an equivalent current rating using balanced three-phase power. If unbalanced three-phase power is supplied the installer must replace the existing factory-installed inverter with an inverter that has a higher current rating to allow for the imbalance. Refer to the installation instructions for additional information and replacement information.

Ordering Information

- Specify motor horsepower and drive kit number when base unit is ordered

FEATURES AND BENEFITS

BLOWER (Continued)

Options/Accessories

Factory Installed

Supply VFD Blower Bypass Control

- Allows unit to operate as a constant air volume (CAV) unit in case of variable frequency drive (VFD) failure

NOTE - Supply VFD Blower Bypass Control is not available with High Static Power Exhaust.

Field Installed

Supply Static Limit Switch

- Manual reset switch for supply static high pressure limit
- Prevents exceeding pressure limit in supply air duct
- Optional Mounting Kit includes tubing and adaptors

ELECTRICAL

SmartWire™ System

- Keyed and color-coded wiring connectors prevent miswiring
- Wire coloring scheme is standardized across all models
- Each connection is intuitively labeled to make troubleshooting and servicing quick and easy

Electrical Plugs

- Positive connection electrical plugs connect common accessories or maintenance parts for easy removal or installation

Phase/Voltage Detection

- Monitors power supply to assure phase is correct at unit start-up
- If phase is incorrect, the unit will not start and an alarm code is reported to the unit controller
- Protects unit from being started with incorrect phasing which could lead to issues such as compressors running backwards
- Voltage detection monitors power supply voltage to assure proper voltage
- If voltage is not correct (over/under voltage conditions) the unit will not start and an alarm code is reported to the unit controller

Required Selections

Voltage Choice

- Specify when ordering base unit

Options/Accessories

Factory Installed

Circuit Breakers

- HACR type
- Overload and short circuit protection
- Factory wired and mounted in the power entry panel
- Current sensitive and temperature activated
- Manual reset

Short-Circuit Current Rating (SCCR)

- Higher short-circuit protection up to 100kA

NOTE - Disconnect Switch is furnished and factory installed with High SCCR option

Factory or Field Installed

Disconnect Switch

- Accessible outside of unit
- Spring loaded weatherproof cover furnished

GFI Service Outlets (2)

- 115V ground fault circuit interrupter (GFCI) type
- Available non-powered, field-wired or factory-wired and powered

Field Installed

GFI Weatherproof Cover

- Single-gang cover
- Heavy-duty UV-resistant polycarbonate case construction
- Hinged base cover with gasket

FEATURES AND BENEFITS

INDOOR AIR QUALITY

11 Air Filters

- Disposable 2 inch MERV 4 filters furnished as standard

Options/Accessories

Factory or Field Installed

Healthy Climate® High Efficiency Air Filters

- Disposable MERV 8 or MERV 13 (Minimum Efficiency Reporting Value based on ASHRAE 52.2) efficiency 2-inch pleated filters
- **Replacement Filter Media Kit With Frame**
- Replaces existing pleated filter media
- Includes washable metal mesh screen and metal frame with clip for holding replaceable non-pleated filter

Field Installed

Healthy Climate® High Efficiency MERV 16 Air Filters

- Disposable MERV 16 (Minimum Efficiency Reporting Value based on ASHRAE 52.2) efficiency 2-inch pleated filters

Indoor Air Quality (CO₂) Sensors

- Monitors CO₂ levels
- Reports to the Lennox® CORE Control, which adjusts economizer dampers as needed

CONTROL SYSTEM

LENNOX® CORE CONTROL SYSTEM

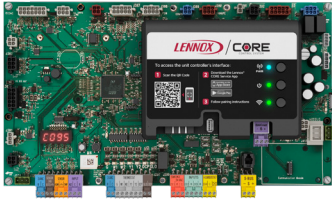

- 12 The Lennox® CORE Control System is designed to accelerate equipment install and service. Standard with all Enlight rooftop units, control system integrates key technologies that lower installation costs, drive system efficiency, and protect your investments.

The Lennox® CORE Unit Controller is a microprocessor-based controller that provides flexible control of all unit functions.

CORE Mobile Service App

- Guided Setup with progress indicators, detailed help, and exportable summaries to manage simple, trouble-free setup, reducing commissioning times
- Enhanced Test Functionality provides real-time sensor readings, trending, and reports that enable easy troubleshooting
- Ability to set and configure parameters of the CORE Control System to manage sequence of operation
- Economizer test function ensures economizer is operating correctly



Additional Features:

- Built-In 7-Segment Display shows Unit Status and active alarms for easy troubleshooting
- Buttons for test and clearing delays
- SmartWire™ System with keyed and removable screw terminals ensure correct field wiring
- Built-in BACnet MS/TP and IP allow open integration to building management systems.
- Two-port Ethernet Switch enables daisy chaining for BACnet IP and automatic firmware updates

NOTE - Unit Internet Connection required.

- Profile setup copies key settings between units with the same configuration to reduce setup time
- USB port allows a technician to download and transfer unit information to help verify service was performed
- USB software updates on the Lennox® CORE Unit Controller enhance functionality without the need to change components
- Unit Controller Software

Configurable Built-In Functions

- Discharge Air Cooling Control
- Up to three distinct Cooling Airflows in Thermostat Mode
- Programmable independent heating, ventilation and cooling blower speeds

- Discharge Air Heating Control
- Economizer Control Options (See Economizer / Exhaust Air / Outdoor Air sections)
- Exhaust Fan Control Modes for fresh air damper position
- Configurable Morning Warm-up
- Night Setback Mode
- Fresh Air Tempering for Improved Ventilation
- Demand Control Ventilation
- Low Ambient Controls for operation down to 0°F
- Humiditrol™ Operation
- Enhanced Dehumidification (Latent Demand Control without hot gas reheat)

Component Protection / Unit Safeguards:

- Compressor Time-Off Delay
- Adjustable Blower On/Off Delay
- Return Air Temperature Limit Control
- Safety Switch Input allows Controller to respond to a external safety switch trip
- Service Relay Output
- Thermostat Bounce Delay
- Smoke Alarm Mode has four choices (unit off, positive pressure, negative pressure, purge)
- "Strike Three" Protection
- Gas Valve Time Delay Between First and Second Stage
- Minimum Compressor Run Time

Control Methods / Interfaces:

- DDC and 24V Thermostat
- BACnet MS/TP and IP
- LONTalk (Factory and Field Option)
- Lennox S-BUS
- Zone Temperature Sensor Input
- Dehumidistat and Humidity Sensor Inputs
- Indoor Air Quality Inputs (2)
- Built-in Control Parameter Defaults
- Permanent Diagnostic Code Storage
- Field Adjustable Control Parameters (Over 200 settings)
- Multiple Configurable Digital Inputs
- LED Indicators
- PC Interface connects the Lennox® CORE Unit Controller to a PC with the Lennox Unit Controller Software

NOTE - Lennox® CORE Control System features vary with the type of rooftop unit in which the control is installed.

CONTROL SYSTEM

LENNOX® CORE CONTROL SYSTEM (continued)

Discharge Air Temperature Sensor (VAV Model Only)

- Sensor sends information to the unit controller to cycle up to 2 stages of heating or 4 stages of cooling to maintain the discharge air setpoints for heating or cooling

NOTE - Sensor is shipped with the VAV unit for remote field installation in the supply duct.

Controls Options

Factory or Field Installed

Dirty Filter Switch

- Senses static pressure increase and issues alarm if necessary

Fresh Air Tempering

- Used in applications with high outside air requirements
- Controller energizes the first stage heat as needed to maintain a minimum supply air temperature for comfort, regardless of the thermostat demand
- When ordered as a factory option, sensor ships with the unit for field installation

Smoke Detector

- Photoelectric type
- Installed in supply air section, return air section or both sections
- Available with power board and single sensor (supply or return) or power board and two sensors (supply and return)
- Power board located in unit control compartment

Commercial Control Systems

Interoperability via BACnet® or LonTalk® Protocols

- Communication compatible with third-party automation systems that support the BACnet Application Specific Controller device profile, LonMark® Space Comfort Controller functional profile, or LonMark Discharge Air Controller functional profile

Field Installed

Thermostats

- Control system and thermostat options, see page 16

OPTIONS / ACCESSORIES

ECONOMIZER

- Economizer operation is set and controlled by the Lennox® CORE unit controller
- Simple plug-in connections from economizer to unit controller for easy installation
- All Enlight rooftop units are equipped with factory installed CEC Title 24 approved sensors for outside, return and discharge air temperature monitoring

NOTE - Optional sensors may be used instead of unit sensors to determine whether outdoor air is suitable for free cooling. See Options/Accessories table.

Factory or Field Installed

13 High Performance Economizer

- Approved for California Title 24 building standards
- Low leakage dampers are Air Movement and Control Association International (AMCA) Class 1A Certified - Maximum 3 CFM per sq. ft. leakage at 1 in. w.g.
- ASHRAE 90.1 and IECC compliant
- Outdoor Air Hood with mist elimination is included when economizer is factory installed and is furnished with economizer when ordered for field installation

NOTE - Downflow or horizontal economizer applications require optional Downflow or Horizontal Barometric Relief Dampers with Exhaust Hood.

- Linked damper action
- High torque 24-volt fully-modulating spring return damper motor
- Return air and outdoor air dampers
- Plug-in connections to unit

NOTE - High Performance Economizers are not approved for use with enthalpy controls in Title 24 applications.

NOTE - The Free Cooling setpoint for Title 24 applications must be set based on the Climate Zone where the system is installed. See Section 140.4 "Prescriptive Requirements for Space Conditioning Systems" of the California Energy Commission's 2022 Building Energy Efficiency Standards.

NOTE - Refer to Installation Instructions for complete setup information.

OPTIONS / ACCESSORIES

ECONOMIZER (continued)

Differential Sensible Control

- Factory setting
- Uses outdoor air and return air sensors that are furnished with the unit
- The Lennox® CORE unit controller compares outdoor air temperature with return air
- When the outdoor air is below the configured setpoint and cooler than return air, the controller activates the economizer

NOTE - Differential Sensible Control can be configured in the field to provide Offset Differential Sensible Control or Single Sensible Control.

NOTE - In Offset Differential Sensible Control mode, the economizer is enabled if the temperature differential (offset) between outdoor air and return air reaches the configured setpoint. In Single Sensible Control mode, the economizer is enabled when outdoor air temperature falls below the configured setpoint.

Global Control

- The unit controller communicates with a DDC system with one global sensor (enthalpy or sensible)
- Determines whether outside air is suitable for free cooling on all units connected to the control system
- Sensor must be field provided

NOTE - Global control with enthalpy is not approved for Title 24 applications.

Factory or Field Installed

Single Enthalpy Temperature Control (Not for Title 24)

- Outdoor air enthalpy sensor enables Economizer if the outdoor enthalpy is less than the setpoint of the control

Differential Enthalpy Control (Not for Title 24)

- Order two Single Enthalpy Controls
- One is field installed in the return air section
- One is installed in the outdoor air section
- Allows the economizer control to select between outdoor air or return air, whichever has lower enthalpy

Field Installed

Outdoor Air CFM Control

- Maintains constant outdoor air volume levels on the supply air fan and varying unit airflows
- Velocity sensor located in the rooftop unit outdoor air section, the Lennox® CORE unit controller changes the Economizer position to help minimize the effect of supply fan speed changes on outdoor air volume levels
- Setpoint for outdoor air volume is established by field testing

NOTE - Not available with Demand Control Ventilation (CO₂ Sensor) or Building Pressure Control.

Building Pressure Control

- Maintains constant building pressure level
- Includes a static pressure transducer and outdoor static pressure assembly

Using differential pressure information between the outdoor air and the building air, the Lennox® CORE unit controller changes the Economizer position to help maintain a constant building pressure

NOTE - Not available with Demand Control Ventilation (CO₂ Sensor) or Outdoor Air CFM Control.

EXHAUST

Factory or Field Installed

14 Downflow Barometric Relief Dampers

- Allow relief of excess air
- Aluminum blade dampers prevent blow back and outdoor air infiltration during off cycle
- Exhaust hood is factory installed when dampers are factory installed with economizer
- Exhaust hood is furnished with dampers when ordered for field installation
- Bird screen furnished

Horizontal Barometric Relief Dampers

- For use when unit is configured for horizontal applications requiring an economizer
- Allows relief of excess air
- Aluminum blade dampers prevent blow back and outdoor air infiltration during off cycle
- Field installed in return air duct
- Bird screen and hood furnished

NOTE - Horizontal Economizer Conversion kit is available for field installation.

OPTIONS / ACCESSORIES

EXHAUST (continued)

Factory or Field Installed

- 15** Standard Static Power Exhaust
- Fans install internal to unit for downflow applications only with economizer option
 - Provides exhaust air pressure relief
 - Interlocked to run when return air dampers are closed and supply air blower is operating
 - Fans run based on air damper position (adjustable)
 - Three 1/3 HP motors
 - 20 in. diameter propeller-type fans
 - Five blades
 - Total power input of 1125 Watts
 - Total air volume of 12,800 cfm at 0 in. w.g.
 - Motor is inherently protected
 - Totally enclosed
 - Steel cabinet and hood painted to match unit

NOTE - Requires optional Downflow Economizer Barometric Relief Dampers. Also see Standard Static Power Exhaust Blower Tables.

Field Installed

High Static Power Exhaust

- Centrifugal-type power exhaust blowers
- Overload and sub-fuse protected
- Ball bearings
- Forward curved blades
- Blower wheel is statically and dynamically balanced
- Adjustable pulleys for speed adjustments

NOTE - High Static Power Exhaust (with VFD) features a solid-state analog pressure transducer control which senses differential pressure between conditioned space and outdoor air to regulate exhaust blower speed. Also see High Static Power Exhaust Blower Tables.

NOTE - High Static Power Exhaust is field installed but must be ordered at the same time as the rooftop unit so the unit can be factory configured for this option.

Control Choices

Damper Position Control

- For Standard Static Power Exhaust without VFD
- Lennox® CORE unit controller controls the power exhaust based on economizer damper position

Field Installed

Differential Pressure Transducer Control

- For Standard Static Power Exhaust or High Static Power Exhaust with VFD
- Lennox® CORE unit controller controls the power exhaust system based on a 0-10VDC signal from a differential pressure transducer, which compares atmospheric pressure to conditioned space static pressure

OUTDOOR AIR

Factory or Field Installed

Motorized Outdoor Air Dampers

- Linked mechanical dampers
- Fully modulating spring return damper motor with plug-in connection
- 0 to 25% (fixed) outdoor air adjustable
- Installs in unit
- Outdoor air hood with bird screen included

NOTE - Outdoor Air Hood is shipped separately in the unit with factory installed dampers for field installation.

Field Installed

Manual Outdoor Air Damper

- Adjustable slide damper
- Installed in unit
- Outdoor air hood with bird screen included

OPTIONS / ACCESSORIES

ROOF CURBS

- Nailer strip furnished (downflow only)
- Mates to unit
- US National Roofing Contractors Approved
- Shipped knocked down

Downflow

Hybrid Roof Curbs

- Interlocking tabs fasten corners together
- No tools required for assembly
- Can also be fastened together with furnished hardware
- Available in 14, 18, and 24 inch heights

Horizontal

- Converts unit from downflow to horizontal (side) air flow
- Return air is on unit
- Supply air is on curb
- Available in 37 inch and 41 inch heights.
- See dimension drawings

NOTE - Requires Horizontal Return Air Panel Kit.

NOTE - Optional Insulation Kit is available to help prevent sweating.

CEILING DIFFUSERS

Field Installed

Ceiling Diffusers

(Flush or Step-Down)

- White powder coat finish on diffuser face and grilles
- Insulated UL listed duct liner
- Diffuser box has collars for duct connection
- Step-down diffusers have double deflection blades
- Flush diffusers have fixed blades
- Provisions for suspending
- Internally sealed to prevent recirculation
- Removable return air grille
- Adapts to T-bar ceiling grids or plaster ceilings

Transitions (Supply and Return)

- Used with diffusers
- Installs in roof curb
- Galvanized steel construction
- Flanges furnished for duct connection to diffusers
- Fully insulated

16 **OVERVIEW**

NOTE - Available for 302H and 360H models with MSAV® Multi-Stage Air Volume option.

- Factory installed option designed to control humidity
- Provides dehumidification on demand using ASHRAE 90.1 recommended method for comfort conditioning humidity control
- Unit comes equipped with one row reheat coil, solenoid valve and humidity controller

BENEFITS

- Improves indoor air quality
- Helps prevent damage due to high humidity levels
- Improves comfort levels by reducing space humidity levels

OPERATION

No Dehumidification Demand

- The unit will operate conventionally whenever there is a demand for cooling or heating and no dehumidification demand
- Free cooling is only permitted when there is no demand for dehumidification

Dehumidification Demand Only

- Reheat operation will initiate on a dehumidification demand and does not require a cooling demand
- The unit will operate in the dehumidification mode until the relative humidity of the conditioned space is below the setpoint
- The reheat coil is sized to provide 68°F to 75°F supply air during reheat operation
- This reduces sensible cooling capacity and extends compressor run time to control humidity when the cooling load is low
- A solenoid valve diverts hot gas from the compressor to the reheat coil
- The cooled and dehumidified air from the evaporator is reheated as it passes through the reheat coil
- The de-superheated and partially condensed refrigerant continues to the outdoor condenser coil where condensing is completed
- The unit will continue to operate in this mode until the dehumidification demand is satisfied

NOTE - See Sequence of Operation for additional information.

Dehumidification and Cooling Demand (Thermostat/ Room Sensor Application)

- If both a dehumidification and a full cooling demand occur, the system will operate in cooling until the cooling demand is satisfied
- Then the system will energize the dehumidification mode

HUMIDITROL® DEHUMIDIFICATION SYSTEM OPTION

REFRIGERANT SCHEMATIC

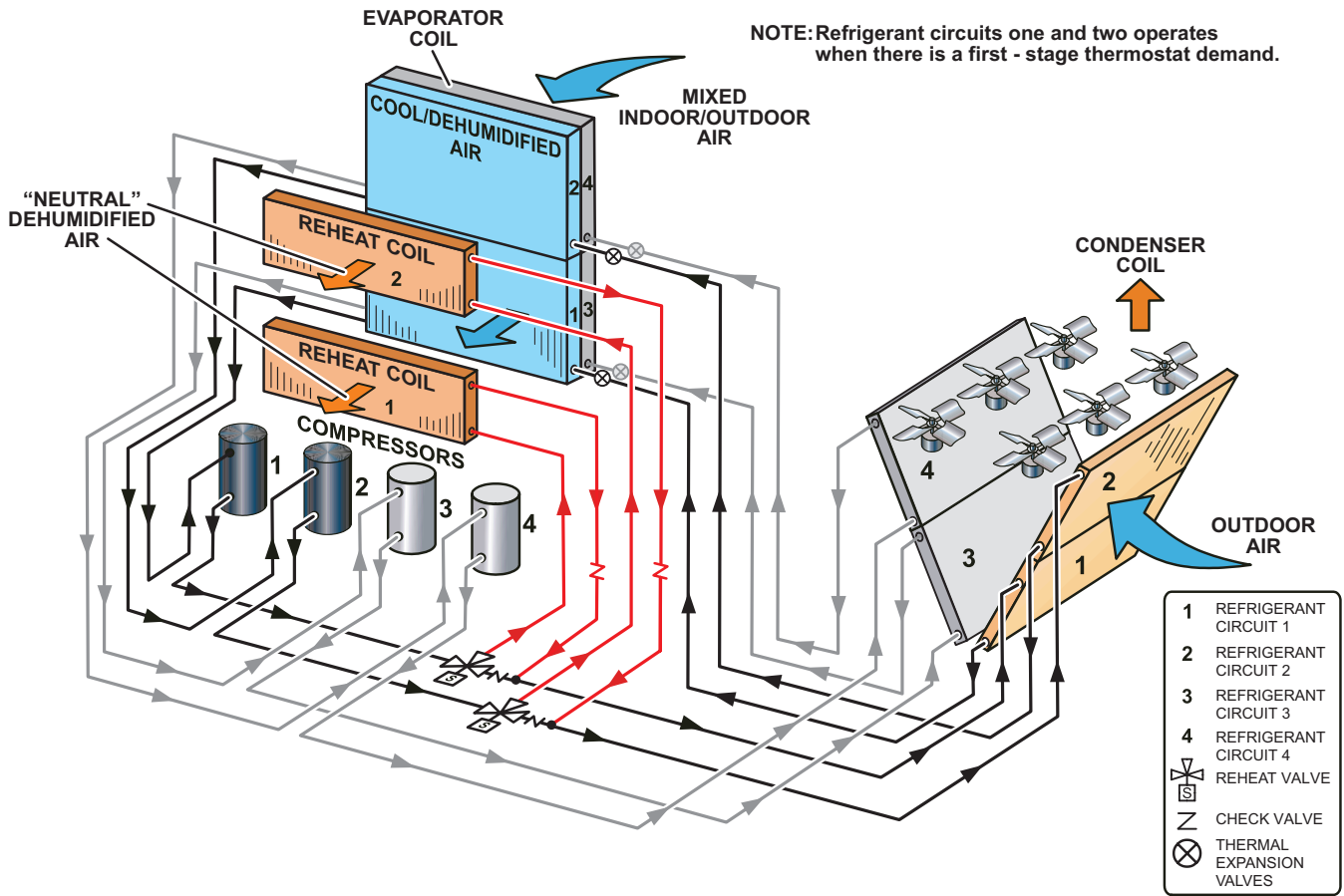

OPTIONAL CONVENTIONAL TEMPERATURE CONTROL SYSTEMS

CS8500 Commercial 7-Day Programmable Thermostat

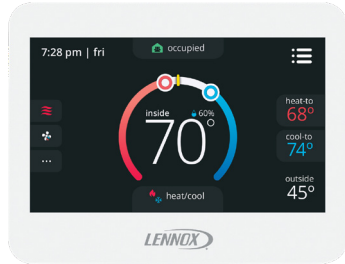

- Fully Communicating Sensor
- Full Color Touchscreen Interface
- Variable Speed System Control (On Compatible Units)
- Up To 4 Heat / 4 Cool
- Built-In Sensors For Temperature, Humidity And Optional CO₂
- Remote Sensor Options For Occupancy, Temperature
- BACnet Capable Options
- 5-2 or 7-Day Scheduling
- Smooth Setback Recovery
- Heat/Cool Auto-Changeover
- Four-Wire Installation
- FDD, ASHRAE, IECC Compliant

CS7500 Commercial 7-Day Programmable Thermostat



- Premium Universal Thermostat
- Full Color Touchscreen Interface
- Up To 4 Heat / 3 Cool
- Built-In Sensors For Temperature and Humidity
- Remote Sensors Options For Temperature, Discharge Air, Outdoor Air
- 5-2 or 7-Day Scheduling
- Smooth Setback Recovery
- Heat/Cool Auto-Changeover
- FDD, ASHRAE, IECC Compliant

CS3000 Commercial 5-2 Day Programmable Thermostat

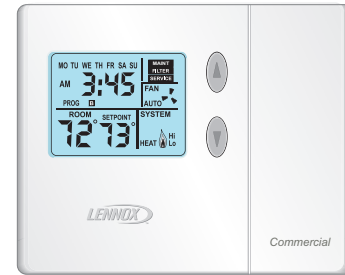

- Conventional Multi-Stage Thermostat
- Intuitive Display
- Push-Button Operation
- Up To 2 Heat / 2 Cool
- Built-In Temperature Sensor
- Remote Temperature Sensing
- Up to 5-2 Day Scheduling
- Smooth Setback Recovery
- Heat/Cool Auto-changeover

Wired Temperature/Humidity Room Sensor (Non-Communicating)



- Terminal blocks for wiring connections
- Five-wire sensor connection
- Off-white plastic enclosure
- Non-adjustable
- Relative humidity range: 0 -100%
- +/- 3% Accuracy

OPTIONAL CONVENTIONAL TEMPERATURE CONTROL SYSTEMS

Description	Order Number
CS8500 Commercial 7 Day Programmable Thermostat	
CS8500 7-Day Thermostat	No CO ₂ Sensing 24K55
	With CO ₂ Sensing 24K53
Sensors/Accessories	¹ Remote non-adjustable wall-mount 10k 47W37
	¹ Remote non-adjustable wall-mount 11k 94L61
Sysbus Network Cable (Yellow) for CS8500 and LCS-5030 Wired Room Sensor	
Twisted pair 100% shielded communication cable, Red and Black	500 ft. box 27M19
22 AWG, yellow jacket, rated at 75°C, 300V, Plenum rated	1000 ft. box 94L63
Insulation - Low smoke PVC, NEC, CMP	2500 ft. roll 68M25
CS7500 Commercial 7-Day Programmable Thermostat	
CS7500 7-Day Thermostat	24K41
Sensors/Accessories	² Remote non-adjustable wall-mount 20k 47W36
	² Remote non-adjustable wall-mount 10k 47W37
	Remote non-adjustable discharge air (duct mount) 19L22
	Outdoor temperature sensor X2658
CS3000 Commercial 5-2 Day Programmable Thermostat	
CS3000 5-2 Day Thermostat	11Y05
Sensors/Accessories	Remote non-adjustable wall mount 10k averaging 47W37
	Thermostat wall mounting plate X2659
Universal Thermostat Guard with Lock (clear)	
	Inside Dimensions (H x W x D) 5-7/8 x 8-3/8 x 3 in. 39P21
Temperature/Humidity Room Sensor	
A335MT13AE1 Wired Temperature/Humidity Room Sensor (Non-Communicating)	21W06

¹ Up to nine of the same type remote temperature sensors can be connected in parallel.

² Remote wall-mount sensors can be applied in any of the following combinations:

One Sensor - (1) 47W36, Two Sensors - (2) 47W37, Three Sensors - (2) 47W36 and (1) 47W37

Four Sensors - (4) 47W36, Five Sensors - (3) 47W36 and (2) 47W37

**UNIT OPERATION WITH 2-STAGE THERMOSTAT OR THIRD PARTY UNIT CONTROLLERS (2 HEAT / 2 COOL)
(THIS SECTION NOT APPLICABLE FOR DISCHARGE AIR TEMPERATURE CONTROL)****SUPPLY AIR BLOWER SPEED**

Unit has the following supply air blower speed settings:

- Ventilation Speed
- Low Cooling Speed
- High Cooling Speed
- Heating Speed
- Smoke Speed (Used only in smoke removal option - not discussed)

COOLING MODE (2 Cool)**¹ Unit Features An Economizer And Outdoor Air Is Suitable****Y1 Demand:**

All compressors are off, supply air blower is set to Low Cooling Speed; economizer modulates (minimum to maximum open position) to maintain 55°F discharge air temperature.

Y2 Demand:

All compressors are off, supply air blower is set to High Cooling Speed, and economizer modulates (minimum to maximum open position) to maintain 55°F discharge air temperature.

NOTE - If economizer stays at maximum open for 3 minutes, 1st stage compressors (compressor 1 and 2) are energized while supply air blower stays on high cooling speed providing maximum cooling capacity.

¹ Outdoor air suitability is determined by the energy state of outdoor ambient (enthalpy or sensible) and its ability to achieve the desired free cooling effects. Outdoor air suitability can also be determined by a third party controller and provided to the RTU via a network connection.

Unit Does Not Feature An Economizer Or Outdoor Air Is Not Suitable**Y1 Demand:**

The first two compressors operate and the supply air blower is activated. The blower is set to the Low Cooling Speed.

Y2 Demand:

All compressors operate and supply air blower is activated. The blower is set to the High Cooling Speed.

Dehumidification Mode

If a unit with Humiditrol® Dehumidification Option receives a call for dehumidification, economizer free cooling is locked out.

Call For Dehumidification, No Y1, Y2 Demand:

Compressors 1 and 2 operate, supply air blower operates at low cooling speed, and both reheat valves are energized.

Y1 Demand With A Call For Dehumidification:

All compressors operate, supply air blower operates at high cooling speed and both reheat valves are energized.

Y2 Demand With A Call For Dehumidification:

All compressors operate, supply air blower operates at high cooling speed, and the reheat valves are de-energized.

HEATING MODE (2 Heat)**W1 Demand:**

The first two stages of mechanical heat are activated; the blower is set to Heating Speed.

W2 Demand:

The third and fourth stages of mechanical heat are activated; the blower is set to the Heating Speed.

**UNIT OPERATION IN ROOM SENSOR MODE OR DISCHARGE AIR TEMPERATURE CONTROL
(4 HEAT / 4 COOL)****SUPPLY AIR BLOWER SPEED**

Unit has the following supply air blower speed settings:

- Ventilation speed
- Cooling Speed 1 (low)
- Cooling Speed 2 (medium-low)
- Cooling Speed 3 (medium-high)
- Cooling Speed 4 (high)
- Heating Speed
- Smoke Speed (Used only in smoke removal option - not discussed)

COOLING MODE (4 Cool)

- Room sensors (when connected to S-Bus) or Discharge air temperature (DAT) can be used to control unit staging.
- DAT default setpoint = 55°F. Unit will stage compressors as required to maintain the setpoint when provided with Y1 thermostat demand.
- Room sensor occupied default setpoint = 75°F. Unit will stage compressors as required to maintain the setpoint.
- Increasing compressor stages provides more cooling capacity while decreasing compressor stages provides less cooling capacity.

¹ Unit Features An Economizer And Outdoor Air Is Suitable**Cooling Stage 1:**

All compressors are off, supply air blower is on Cooling Speed 1 to minimize blower power consumption, economizer modulates (minimum to maximum open position) to maintain setpoint.

Cooling Stage 2:

All compressors are off, supply air blower is on Cooling Speed 4 to provide higher cooling capacity, and economizer modulates to maintain setpoint. If economizer stays at maximum open for 3 minutes, compressor 1 is energized while supply air blower stays on Cooling Speed 4. After compressor 1 is energized, the economizer stays at maximum open.

Cooling Stage 3:

Compressor 1 and 2 are energized while supply air blower is on Cooling speed 4 to provide even higher cooling capacity.

Cooling Stage 4:

All compressors are energized while supply air blower is on Cooling speed 4 to provide maximum cooling capacity. ¹ Outdoor air suitability is determined by the energy state of outdoor ambient (enthalpy or sensible) and its ability to achieve the desired free cooling effects. Outdoor air suitability can also be determined by a third party controller and provided to the RTU via a network connection.

Unit Does Not Feature An Economizer Or Outdoor Air Is Not Suitable**Cooling Stage 1:**

Compressor 1 operates and supply air blower operates at Cooling Speed 1.

Cooling Stage 2:

Compressors 1 and 2 operate and supply air blower operates at Cooling Speed 2.

Cooling Stage 3:

Compressors 1, 2, and 3 operate and supply air blower operates at Cooling Speed 3.

Cooling Stage 4:

All compressors operate and supply air blower operates at Cooling Speed 4.

**UNIT OPERATION IN ROOM SENSOR MODE OR DISCHARGE AIR TEMPERATURE CONTROL
(4 HEAT / 4 COOL) (CONTINUED)****Dehumidification Mode**

If a unit with Humiditrol® Dehumidification Option receives a call for dehumidification, economizer free cooling is locked out.

Call For Dehumidification, No Y1, Y2, Y3, Y4 Demand:

Compressors 1 and 2 operate, supply air blower operates at medium-low cooling speed, and both reheat valves are energized.

Y1 Demand With A Call For Dehumidification:

Compressors 1, 2, and 3 operate, supply air blower operates at high cooling speed and both reheat valves are energized.

Y2 Demand With A Call For Dehumidification:

All compressors operate, supply air blower operates at high cooling speed and both reheat valves are energized.

Y3 Demand With A Call For Dehumidification:

All compressors operate, supply air blower operates at high cooling speed, and the reheat valve of compressor 1 is energized while the reheat valve of compressor 2 is de-energized.

Y4 Demand With A Call For Dehumidification:

All compressors operate, supply air blower operates at high cooling speed, and the reheat valves are de-energized.

HEATING MODE (4 Heat) HEATING MODE (4 Heat)

- Room sensors (when connected to S-Bus) or Discharge air temperature (DAT) can be used to control up to four stages of electric heat.
- DAT default setpoint = 110°F. Unit will stage heating as required to maintain the setpoint when provided with W1 demand.
- Room sensor occupied setpoint default = 70°F. Unit will stage heating as required to maintain the setpoint.
- Increasing heat stages provides more heating capacity while decreasing heat stages provides less heating capacity.
- Blower set to Heating Speed for all stages.

Heating Stage 1:

The first stage of mechanical heat is activated; gas valve one is in low fire mode. This is ~33% of heating capacity.

Heating Stage 2 :

The first and second stages of mechanical heat are activated; gas valves one and two are in low fire mode. This is ~66% of heating capacity.

Heating Stage 3:

Gas valve one is in high fire mode; gas valve two is in low fire mode. This is ~83% of heating capacity.

Heating Stage 4:

Gas valves one and two are in high fire mode. This is 100% of heating capacity.

UNITS IN ZONING APPLICATIONS OPERATING WITH DISCHARGE AIR CONTROL (4 HEAT / 4 COOL)**SUPPLY AIR BLOWER SPEED**

Unit has the following supply air blower speed settings:

- Ventilation Speed
- Cooling Speed - Fully modular based on supply duct static pressure
- Heating Speed
- Smoke Speed (Used only in smoke removal option - not discussed)

COOLING MODE (4 Cool)

- Discharge air temperature (DAT) can be used to control unit staging.
- DAT default setpoint = 55°F. Unit will stage compressors as required to maintain the setpoint when provided with Y1 thermostat demand.
- Increasing compressor stages provides more cooling capacity while decreasing compressor stages provides less cooling capacity.

¹ Unit Features An Economizer And Outdoor Air Is Suitable**Cooling Stage 1:**

All compressors are off, supply air blower operates to maintain duct static pressure, economizer modulates (minimum to maximum open position) to maintain 55°F supply air temperature (default unit controller setting).

Cooling Stage 2:

All compressors are off, supply air blower operates to maintain duct static pressure, and economizer modulates to maintain 55°F supply air temperature. If economizer stays at maximum open for 3 minutes, compressor 1 is energized while supply air blower operates to maintain duct static pressure. After compressor 1 is energized, the economizer stays at maximum open.

Cooling Stage 3:

Compressor 1 and 2 are energized while supply air blower operates to maintain duct static pressure.

Cooling Stage 4:

All compressors are energized while supply air blower operates to maintain duct static pressure.

¹ Outdoor air suitability is determined by the energy state of outdoor ambient (enthalpy or sensible) and its ability to achieve the desired free cooling effects. Outdoor air suitability can also be determined by a third party controller and provided to the RTU via a network connection.

Unit Does Not Feature An Economizer Or Outdoor Air Is Not Suitable**Cooling Stage 1:**

Compressor 1 operates and supply air blower operates to maintain duct static pressure.

Cooling Stage 2:

Compressors 1 and 2 operate and supply air blower operates to maintain duct static pressure.

Cooling Stage 3:

Compressors 1, 2, and 3 operate and supply air blower operates to maintain duct static pressure.

Cooling Stage 4:

All compressors operate and supply air blower operates to maintain duct static pressure.

**UNITS IN ZONING APPLICATIONS OPERATING WITH DISCHARGE AIR CONTROL (4 HEAT / 4 COOL)
(CONTINUED)****HEATING MODE (4 Heat)**

Discharge air temperature (DAT) can be used to control unit staging.

- DAT default setpoint = 110°F. Unit will stage heating as required to maintain the setpoint when provided with W1 demand.
- Increasing heat stages provides more heating capacity while decreasing heat stages provides less heating capacity.
- Blower set to Heating Speed for all stages.

Heating Stage 1:

The first stage of mechanical heat is activated; gas valve one is in low fire mode. This is ~33% of heating capacity.

Heating Stage 2:

The first and second stages of mechanical heat are activated; gas valves one and two are in low fire mode. This is ~66% of heating capacity.

Heating Stage 3:

Gas valve one is in high fire mode; gas valve two is in low fire mode. This is ~83% of heating capacity.

Heating Stage 4:

Gas valves one and two are in high fire mode. This is 100% of heating capacity.

Modulating Outdoor Air Damper

The minimum damper position for “occupied low blower” and “occupied high blower” is adjusted during unit setup to provide minimum fresh air requirements per ASHRAE 62.1 at the corresponding supply air blower speeds.

- When supply air blower is off or the unit is in unoccupied mode, the outdoor air damper is closed.
- When unit is in occupied mode and supply air blower is operating at a speed below the “midpoint” blower speed, the outdoor air damper is at minimum “low blower” position.
- When unit is in occupied mode and supply air blower is operating at a speed equal to or above the “midpoint” blower speed, the outdoor air damper is at minimum “high blower” position.

NOTE - The “midpoint” blower speed is an average of the minimum and maximum blower speed ((minimum speed + maximum speed) divided by 2).

OPTIONS / ACCESSORIES

Item Description	Order Number	Size		
		302	360	
COOLING SYSTEM				
Condensate Drain Trap	PVC	22H54	X	X
	Copper	76W27	X	X
Drain Pan Overflow Switch		21Z07	OX	OX
Stainless Steel Condensate Drain Pan		83W42	OX	OX
GAS HEAT				
Combustion Air Intake Extensions (Order 2 Kits)		89L97	X	X
Gas Heat Input	Standard - 260 kBtuh input	Factory	O	O
	Medium - 360 kBtuh input	Factory	O	O
	High - 480 kBtuh input	Factory	O	O
LPG/Propane Conversion Kits (Order 2 Kits)	Standard Heat	14N28	X	X
	Medium Heat	14N29	X	X
	High Heat	14N30	X	X
Low Temperature Vestibule Heater	208/230V-3ph	58W28	X	X
	460V-3ph	58W29	X	X
	575V-3ph	58W30	X	X
Stainless Steel Heat Exchanger		Factory	O	O
Vertical Vent Extension		42W16	X	X
BLOWER - SUPPLY AIR				
Blower Type	MSAV® Multi-Stage Air Volume	Factory	O	O
	VAV Variable Air Volume	Factory	O	O
Motors	Belt Drive (standard efficiency) - 5 HP	Factory	O	O
	Belt Drive (standard efficiency) - 7.5 HP	Factory	O	O
	Belt Drive (standard efficiency) - 10 HP	Factory	O	O
	Supply VFD Blower Bypass	Factory	O	O
Drive Kits See Blower Data Tables for usage and selection	Kit #1 740-895 rpm	Factory	O	O
	Kit #2 870-1045 rpm	Factory	O	O
	Kit #3 715-880 rpm	Factory	O	O
	Kit #4 770-965 rpm	Factory	O	O
	Kit #5 660-810 rpm	Factory	O	O
	Kit #6 770-965 rpm	Factory	O	O
	Kit #7 570-720 rpm	Factory	O	O
	Kit #8 480-630 rpm	Factory	O	O
	Kit #9 410-535 rpm	Factory	O	O
CABINET				
Combination Coil/Hail Guards		13T16	OX	OX
Corrosion Protection		Factory	O	O
Horizontal Return Air Panel Kit		38K48	X	X

NOTE - Order numbers shown are for ordering field installed accessories.

OX - Configure To Order (Factory Installed) or Field Installed

O = Configure To Order (Factory Installed)

X = Field Installed

OPTIONS / ACCESSORIES

Item Description	Order Number	Size		
		302	360	
CONTROLS				
Commercial Controls	LonTalk® Module	54W27	OX	OX
	Novar® LSE	Factory	O	O
Dirty Filter Switch		53W68	OX	OX
Fresh Air Tempering		21Z08	OX	OX
Smoke Detector - Supply or Return (Power board and one sensor)		37G73	OX	OX
Smoke Detector - Supply and Return (Power board and two sensors)		37G74	OX	OX
INDOOR AIR QUALITY				
Air Filters				
Healthy Climate® High Efficiency Air Filters 20 x 20 x 2 - order 12 per unit	MERV 8	54W21	OX	OX
	MERV 13	52W39	OX	OX
	MERV 16	21U40	X	X
Replaceable Media Filter with Metal Mesh Frame (includes Non-Pleated Filter Media) 20 x 20 x 2- order 12 per unit		44N60	X	X
Indoor Air Quality (CO₂) Sensors				
Sensor - Wall-mount, off-white plastic cover with LCD display		24C58	X	X
Sensor - Wall-mount, off-white plastic cover, no display		23V86	X	X
Sensor - Black plastic case, LCD display, rated for plenum mounting		87N52	X	X
Sensor - Black plastic case, no display, rated for plenum mounting		23V87	X	X
CO ₂ Sensor Duct Mounting Kit - for downflow applications		23Y47	X	X
Aspiration Box - for duct mounting non-plenum rated CO ₂ sensors (24C58)		90N43	X	X
ELECTRICAL				
Voltage 60 hz	208/230V - 3 phase	Factory	O	O
	460V - 3 phase	Factory	O	O
	575V - 3 phase	Factory	O	O
² Short-Circuit Current Rating (SCCR) of 100kA (includes Phase/Voltage Detection)		Factory	O	O
³ Disconnect Switch - See Electrical Data Tables on page 38 for selection	80 amp	54W88	OX	OX
	150 amp	54W89	OX	OX
	250 amp	90W82	OX	OX
GFI Service Outlets	15 amp non-powered, field-wired (208/230V, 460V only)	74M70	OX	OX
	^{4, 5} 15 amp factory-wired and powered (208/230V, 460V)	Factory	O	O
	⁶ 20 amp non-powered, field-wired (208/230V, 460V, 575V)	67E01	X	X
	⁶ 20 amp non-powered, field-wired (575V)	Factory	O	O
Weatherproof Cover for GFI		10C89	X	X
Phase/Voltage Detection		Factory	O	O

¹ Lamps operate on 110-230V single-phase power supply. Step-down transformer may be ordered separately for 460V and 575V units. Alternately, 110V power supply may be used to directly power the UVC ballast(s).

² SCCR option is not available if the MOCP of the configured unit is greater than 200A.

³ Disconnect Switch is furnished and factory installed with SCCR option

⁴ If a factory installed disconnect switch is ordered with a factory installed GFI, the default disconnect size is 150 amps.

⁵ Unit powered GFI Service Outlets are not available with SCCR option.
Disconnect Switch or Circuit Breaker is required with unit powered GFI Service Outlets.

⁶ Canada requires a minimum 20 amp circuit. Select 20 amp, non-powered, field wired GFI.

NOTE - Order numbers shown are for ordering field installed accessories.

OX - Configure To Order (Factory Installed) or Field Installed

O = Configure To Order (Factory Installed)

X = Field Installed

OPTIONS / ACCESSORIES

Item Description	Order Number	Size	
		302	360
7 HUMIDITROL® CONDENSER REHEAT OPTION			
Humiditrol® Dehumidification Option	Factory	O	O
ECONOMIZER			
High Performance Economizer (Approved for California Title 24 Building Standards / AMCA Class 1A Certified)			
High Performance Economizer Downflow or Horizontal Applications - Includes Outdoor Air Hood, order Downflow or Horizontal Barometric Relief Dampers separately.	18X87	OX	OX
Economizer Controls			
Differential Enthalpy (Not for Title 24)	Order 2 21Z09	OX	OX
Sensible Control	Sensor is Furnished Factory	O	O
Single Enthalpy (Not for Title 24)	21Z09	OX	OX
Global	Sensor Field Provided Factory	O	O
Building Pressure Control	13J77	X	X
Differential Sensible	Sensor is Furnished Factory	O	O
Outdoor Air CFM Control	13J76	X	X
Barometric Relief Dampers With Exhaust Hood			
Downflow Barometric Relief Dampers	76W17	OX	OX
Horizontal Barometric Relief Dampers	33K78	OX	OX
OUTDOOR AIR			
Outdoor Air Dampers With Outdoor Air Hood			
Motorized	18X89	OX	OX
Manual	18X88	X	X
POWER EXHAUST			
Standard Static, SCCR Rated	208/230V 74W21	OX	OX
	460V 74W22	OX	OX
	575V 74W23	OX	OX
High Static with VFD 2 HP (731 - 932 rpm)	208/230V 83M89	X	X
	460V 83M90	X	X
	575V 83M91	X	X
Power Exhaust Control			
Pressure Transducer Control	13J77	X	X

⁷ Available for 302H and 360H models only with MSAV® Multi-Stage Air Volume option.

NOTE - Order numbers shown are for ordering field installed accessories.

OX - Configure To Order (Factory Installed) or Field Installed

O = Configure To Order (Factory Installed)

X = Field Installed

OPTIONS / ACCESSORIES

Item Description	Order Number	Size		
		302	360	
ROOF CURBS				
Hybrid Roof Curbs, Downflow				
14 in. height	11F62	X	X	
18 in. height	11F63	X	X	
24 in. height	11F64	X	X	
Standard Roof Curbs, Horizontal - Requires Horizontal Return Air Panel Kit				
30 in. height - slab applications	11T90	X	X	
41 in. height - rooftop applications	11T97	X	X	
Horizontal Return Air Panel Kit				
Required for Horizontal Applications with Roof Curb	38K48	X	X	
Insulation Kit For Standard Horizontal Roof Curbs				
For 30 in. Curb	73K33	X	X	
For 41 in. Curb	73K35	X	X	
CEILING DIFFUSERS				
Step-Down - Order one	LARTD30/36S	45K74	X	X
Flush - Order one	LAFD30/36S	45K75	X	X
Transitions (Supply and Return) - Order one	LASRT30/36	33K80	X	X

NOTE - Order numbers shown are for ordering field installed accessories.

OX - Configure To Order (Factory Installed) or Field Installed

O = Configure To Order (Factory Installed)

X = Field Installed

SPECIFICATIONS **25 TON**

Model		LGT302H5V	LGT302H5M	
Nominal Tonnage		25 Ton	25 Ton	
Efficiency Type		High	High	
Blower Type		VAV Variable Air Volume	MSAV® Multi-Stage Air Volume	
Cooling Performance	Gross Cooling Capacity - Btuh	308,000	308,000	
	¹ Net Cooling Capacity (Btuh)	298,000	298,000	
	¹ AHRI Rated Air Flow (cfm)	8200	8200	
	Total Unit Power - kW	26.5	26.5	
	¹ IEER (Btuh/Watt)	14.3	15.6	
	¹ EER (Btuh/Watt)	11.2	11.2	
Sound Rating Number		dBA 95	95	
Refrigerant Charge		Refrigerant Type R-454B		
Without Reheat	Circuit 1	6 lbs. 12 oz.	6 lbs. 12 oz.	
		Circuit 2	6 lbs. 8 oz.	
		Circuit 3	6 lbs. 11 oz.	
		Circuit 4	6 lbs. 13 oz.	
	With Reheat	Circuit 1	---	6 lbs. 12 oz.
		Circuit 2	---	6 lbs. 8 oz.
		Circuit 3	---	6 lbs. 11 oz.
		Circuit 4	---	6 lbs. 13 oz.
Gas Heating Options Available		See page 29		
Compressor Type (number)		Scroll (4)	Scroll (4)	
Outdoor Coils	Net face area - ft. ² (total)	68.3	68.3	
	Number of rows	1	1	
	Fins - in.	23	23	
Outdoor Coil Fans	Motor HP (number and type)	1/3 (6 PSC)	1/3 (6 PSC)	
	Rpm	1075	1075	
	Watts (total)	2500	2500	
	Diameter (Number) - in.	(6) 24	(6) 24	
	Blades	3	3	
	Total Air volume - cfm	21,500	21,500	
Indoor Coils	Net face area - ft. ² (total)	31.40	31.40	
	Tube diameter - in.	3/8	3/8	
	Rows	4	4	
	Fins - in.	14	14	
	Condensate drain size (NPT) - in.	(1) 1 in.	(1) 1 in.	
Expansion device type		Balanced Port Thermostatic Expansion Valve,removable power head		
³ Indoor Blower and Kit Selection	Nominal motor HP	5, 7.5, 10		
	Maximum usable motor output (US Only)	5.75, 8.63, 11.5		
	Motor - Drive kit number	5 HP Kit 5 660-810 rpm Kit 6 770-965 rpm Kit 7 570-720 rpm Kit 8 480-630 rpm Kit 9 410-535 rpm		
		7.5 HP Kit 3 715-880 rpm Kit 4 770-965 rpm		
		10 HP Kit 1 740-895 rpm Kit 2 870-1045 rpm		
	Wheel (Number) diameter x width - in.	(2) 18 x 15		
	Filters	Type of filter	Fiberglass, disposable	
		Number and size - in.	(12) 20 x 20 x 2	
	Line voltage data (Volts-Phase-Hz)		208/230-3-60, 460-3-60, 575-3-60	

NOTE - Net capacity includes evaporator blower motor heat deduction. Gross capacity does not include evaporator blower motor heat deduction.
¹ Tested at conditions included in with AHRI Standard 340/360; 95°F outdoor air temperature and 80°F db/67°F wb entering evaporator air; minimum external duct static pressure.
² Using total air volume and system static pressure requirements determine from blower performance tables rpm and motor output required. Maximum usable output of motors furnished are shown. In Canada, nominal motor output is also maximum usable motor output. If motors of comparable output are used, be sure to keep within the service factor limitations outlined on the motor nameplate.

SPECIFICATIONS **30 TON**

Model		LGT360H5V	LGT360H5M	
Nominal Tonnage		30 Ton	30 Ton	
Efficiency Type		High	High	
Blower Type		VAV Variable Air Volume	MSAV® Multi-Stage Air Volume	
Cooling Performance	Gross Cooling Capacity - Btuh	359,000	359,000	
	¹ Net Cooling Capacity (Btuh)	348,000	348,000	
	¹ AHRI Rated Air Flow (cfm)	8650	8650	
	Total Unit Power - kW	33.0	33.0	
	¹ IEER (Btuh/Watt)	13.5	14	
	¹ EER (Btuh/Watt)	10.5	10.5	
Sound Rating Number		dBA	95	
Refrigerant Charge		Refrigerant Type	R-454B	
Without Reheat Option With Reheat Option	Circuit 1	6 lbs. 6 oz.	6 lbs. 6 oz.	
		Circuit 2	6 lbs. 13 oz.	6 lbs. 13 oz.
			Circuit 3	6 lbs. 10 oz.
		Circuit 4		6 lbs. 6 oz.
	Circuit 1		---	7 lbs. 12 oz.
	Circuit 2		---	7 lbs. 8 oz.
	Circuit 3		---	6 lbs. 14 oz.
	Circuit 4	---	6 lbs. 12 oz.	
Gas Heating Options Available		See page 29		
Compressor Type (number)		Scroll (4)	Scroll (4)	
Outdoor Coils	Net face area - ft. ² (total)	68.3	68.3	
	Number of rows	1	1	
	Fins - in.	23	23	
Outdoor Coil Fans	Motor HP (number and type)	1/3 (6 PSC)	1/3 (6 PSC)	
	Rpm	1075	1075	
	Watts (total)	2500	2500	
	Diameter (Number) - in.	(6) 24	(6) 24	
	Blades	3	3	
	Total Air volume - cfm	21,500	21,500	
Indoor Coils	Net face area - ft. ² (total)	31.40	31.40	
	Tube diameter - in.	3/8	3/8	
	Rows	4	4	
	Fins - in.	14	14	
	Condensate drain size (NPT) - in.	(1) 1 in.	(1) 1 in.	
		Balanced Port Thermostatic Expansion Valve,removable power head		
³ Indoor Blower and Kit Selection	Nominal motor HP	5, 7.5, 10		
	Maximum usable motor output (US Only)	5.75, 8.63, 11.5		
	Motor - Drive kit number	5 HP		
		Kit 5 660-810 rpm		
		Kit 6 770-965 rpm		
			7.5 HP	
			Kit 3 715-880 rpm	
			Kit 4 770-965 rpm	
			10 HP	
			Kit 1 740-895 rpm	
		Kit 2 870-1045 rpm		
Wheel (Number) diameter x width - in.		(2) 18 x 15		
Filters	Type of filter	Fiberglass, disposable		
	Number and size - in.	(12) 20 x 20 x 2		
Line voltage data (Volts-Phase-Hz)		208/230-3-60, 460-3-60, 575-3-60		

NOTE - Net capacity includes evaporator blower motor heat deduction. Gross capacity does not include evaporator blower motor heat deduction.
¹ Tested at conditions included in with AHRI Standard 340/360; 95°F outdoor air temperature and 80°F db/67°F wb entering evaporator air; minimum external duct static pressure.
² Using total air volume and system static pressure requirements determine from blower performance tables rpm and motor output required. Maximum usable output of motors furnished are shown. In Canada, nominal motor output is also maximum usable motor output. If motors of comparable output are used, be sure to keep within the service factor limitations outlined on the motor nameplate.

SPECIFICATIONS

GAS HEAT

Model			LGT302 LGT360		
Heat Input Type			Standard (S)	Medium (M)	High (H)
Number of Gas Heat Stages			2	2	2
Gas Heating Performance (Two-Stage)	Input - Btuh	First Stage	169,000	234,000	312,000
		Second Stage	260,000	360,000	480,000
	Output - Btuh	First Stage	---	---	---
		Second Stage	211,000	292,000	389,000
¹ Gas Heating Performance (Four-Stage)	Input - Btuh	First Stage	85,000	117,000	156,000
		Second Stage	169,000	234,000	312,000
		Third Stage	214,000	297,000	396,000
		Fourth Stage	260,000	360,000	480,000
	Output - Btuh	First Stage	---	---	---
		Second Stage	---	---	---
		Third Stage	---	---	---
		Fourth Stage	211,000	292,000	389,000
Temperature Rise Range - °F			15 - 45	30 - 60	40 - 70
Thermal Efficiency			81%	81%	81%
Gas Supply Connections			1 in. npt	1 in. npt	1 in. npt
Recommended Gas Supply Pressure - in. w.g.	Natural		7	7	7
	LPG/Propane		11	11	11

¹ Two-stage heat models can be operated with four stages of gas heating when controlled in either zone sensor, Discharge Air Control, or fresh air tempering mode on the Lennox® CORE unit controller.

HIGH ALTITUDE DERATE

Units may be installed at altitudes up to 2000 feet above sea level without any modification.

At altitudes above 2000 feet, units must be derated to match gas manifold pressures shown in table below.

At altitudes above 4500 feet unit must be derated 2% for each 1000 feet above sea level.

NOTE – This is the only permissible derate for these units.

TWO-STAGE

Gas Heat Type (Two-Stage)	Altitude - ft.	Gas Manifold Pressure - in. w.g.		Input Rate Natural Gas or LPG/Propane - Btuh	
		Natural Gas	LPG/Propane Gas	First Stage	Second Stage
Standard (S)	2001 - 4500	3.4	9.6	169,000	249,000
Medium (M)	2001 - 4500	3.4	9.6	234,000	345,000
High (H)	2001 - 4500	3.4	9.6	312,000	460,000

FOUR-STAGE

¹ Gas Heat Type (Four-Stage)	Altitude - ft.	Gas Manifold Pressure - in. w.g.		Input Rate Natural Gas or LPG/Propane - Btuh			
		Natural Gas	LPG/Propane Gas	First Stage	Second Stage	Third Stage	Fourth Stage
Standard (S)	2001 - 4500	3.4	9.6	84,000	169,000	209,000	249,000
Medium (M)	2001 - 4500	3.4	9.6	117,000	234,000	289,000	345,000
High (H)	2001 - 4500	3.4	9.6	156,000	312,000	386,000	460,000

¹ Four-Stage Gas Heating is field configured.

RATINGS

NOTE – For Temperatures and Capacities not shown in tables, see bulletin – Cooling Unit Rating Table Correction Factor Data in Miscellaneous Engineering Data section.

25 TON HIGH EFFICIENCY LGT302H5M (2 COMPRESSORS - PART LOAD) - MSAV® (MULTI-STAGE AIR VOLUME)

Entering Wet Bulb Temperature	Total Air Volume	Outdoor Air Temperature Entering Outdoor Coil																			
		65°F					75°F					85°F					95°F				
		Total Cool Cap.	Comp. Motor Input	Sensible To Total Ratio (S/T)			Total Cool Cap.	Comp. Motor Input	Sensible To Total Ratio (S/T)			Total Cool Cap.	Comp. Motor Input	Sensible To Total Ratio (S/T)			Total Cool Cap.	Comp. Motor Input	Sensible To Total Ratio (S/T)		
				Dry Bulb					Dry Bulb					Dry Bulb					Dry Bulb		
cfm	kBtuh	kW	75°F	80°F	85°F	kBtuh	kW	75°F	80°F	85°F	kBtuh	kW	75°F	80°F	85°F	kBtuh	kW	75°F	80°F	85°F	
63°F	4000	161.9	6.75	0.69	0.81	0.92	156.9	7.79	0.7	0.82	0.94	151.4	8.89	0.7	0.83	0.96	145.7	10.1	0.72	0.85	0.98
	5000	171	6.76	0.72	0.86	0.99	165.6	7.82	0.73	0.88	1	159.6	8.94	0.74	0.89	1	153.3	10.16	0.76	0.92	1
	6000	178	6.76	0.76	0.92	1	171.9	7.83	0.77	0.94	1	165.5	8.98	0.79	0.96	1	158.8	10.21	0.81	0.98	1
67°F	4000	170	6.76	0.55	0.67	0.77	164.7	7.82	0.56	0.67	0.78	158.8	8.94	0.57	0.68	0.8	153	10.16	0.58	0.69	0.81
	5000	179.8	6.76	0.58	0.7	0.83	173.7	7.84	0.58	0.71	0.85	167.6	8.99	0.59	0.72	0.86	161	10.23	0.6	0.74	0.89
	6000	186.8	6.75	0.59	0.74	0.89	180.3	7.86	0.6	0.75	0.9	173.6	9.02	0.61	0.77	0.93	166	10.27	0.63	0.79	0.95
71°F	4000	177.6	6.76	0.44	0.54	0.65	171.8	7.83	0.44	0.55	0.65	166	8.98	0.44	0.56	0.66	159.4	10.21	0.45	0.56	0.67
	5000	187.7	6.75	0.45	0.57	0.68	182.2	7.86	0.45	0.57	0.69	175.2	9.03	0.45	0.58	0.71	168.3	10.29	0.45	0.59	0.72
	6000	195.9	6.75	0.45	0.58	0.72	189	7.87	0.45	0.59	0.73	181.4	9.06	0.45	0.6	0.75	173.5	10.33	0.46	0.62	0.77

25 TON HIGH EFFICIENCY LGT302H5M (4 COMPRESSORS - FULL LOAD) - MSAV® (MULTI-STAGE AIR VOLUME)

Entering Wet Bulb Temperature	Total Air Volume	Outdoor Air Temperature Entering Outdoor Coil																			
		85°F					95°F					105°F					115°F				
		Total Cool Cap.	Comp. Motor Input	Sensible To Total Ratio (S/T)			Total Cool Cap.	Comp. Motor Input	Sensible To Total Ratio (S/T)			Total Cool Cap.	Comp. Motor Input	Sensible To Total Ratio (S/T)			Total Cool Cap.	Comp. Motor Input	Sensible To Total Ratio (S/T)		
				Dry Bulb					Dry Bulb					Dry Bulb					Dry Bulb		
cfm	kBtuh	kW	75°F	80°F	85°F	kBtuh	kW	75°F	80°F	85°F	kBtuh	kW	75°F	80°F	85°F	kBtuh	kW	75°F	80°F	85°F	
63°F	8000	311.7	17.95	0.72	0.83	0.93	299.5	20.37	0.73	0.85	0.95	287.3	23.02	0.74	0.86	0.96	274.4	26.02	0.75	0.88	0.98
	10000	327.7	18.04	0.77	0.89	0.99	314.6	20.51	0.78	0.91	1	301.5	23.19	0.8	0.92	1	288	26.18	0.82	0.94	1
	12000	339	18.1	0.81	0.94	1	325.6	20.6	0.84	0.96	1	312.1	23.32	0.85	0.98	1	297.8	26.31	0.86	1	1
67°F	8000	326.9	18.02	0.57	0.69	0.81	312.7	20.47	0.57	0.71	0.82	299.4	23.19	0.59	0.72	0.84	284.5	26.12	0.6	0.73	0.86
	10000	337.9	18.1	0.61	0.74	0.87	324.3	20.59	0.61	0.76	0.89	309.7	23.29	0.63	0.78	0.9	294.1	26.23	0.64	0.81	0.92
	12000	347.6	18.16	0.64	0.8	0.92	332.6	20.65	0.65	0.81	0.94	318.1	23.37	0.65	0.84	0.96	303.2	26.35	0.66	0.86	0.98
71°F	8000	344.2	18.14	0.43	0.56	0.66	330.6	20.64	0.44	0.56	0.68	315.3	23.35	0.44	0.57	0.69	299.6	26.31	0.44	0.58	0.71
	10000	355.9	18.2	0.45	0.6	0.72	340.9	20.72	0.46	0.59	0.74	325.2	23.45	0.45	0.61	0.75	309.1	26.43	0.47	0.62	0.77
	12000	364.5	18.24	0.45	0.62	0.77	348.9	20.79	0.46	0.63	0.8	332.5	23.52	0.46	0.65	0.81	316.2	26.52	0.47	0.66	0.83

25 TON HIGH EFFICIENCY LGT302H5V (1 COMPRESSOR - PART LOAD) - VARIABLE AIR VOLUME

Entering Wet Bulb Temperature	Total Air Volume	Outdoor Air Temperature Entering Outdoor Coil																			
		65°F					75°F					85°F					95°F				
		Total Cool Cap.	Comp. Motor Input	Sensible To Total Ratio (S/T)			Total Cool Cap.	Comp. Motor Input	Sensible To Total Ratio (S/T)			Total Cool Cap.	Comp. Motor Input	Sensible To Total Ratio (S/T)			Total Cool Cap.	Comp. Motor Input	Sensible To Total Ratio (S/T)		
				Dry Bulb					Dry Bulb					Dry Bulb					Dry Bulb		
cfm	kBtuh	kW	75°F	80°F	85°F	kBtuh	kW	75°F	80°F	85°F	kBtuh	kW	75°F	80°F	85°F	kBtuh	kW	75°F	80°F	85°F	
63°F	2000	63.6	3.43	0.63	0.71	0.79	61.9	3.9	0.63	0.71	0.79	60	4.43	0.63	0.71	0.8	58.5	5	0.63	0.72	0.81
	2500	69	3.44	0.63	0.73	0.81	67.2	3.93	0.64	0.73	0.82	65.2	4.46	0.64	0.74	0.83	63.2	5.05	0.65	0.75	0.85
	3000	73.6	3.47	0.65	0.75	0.85	71.9	3.96	0.66	0.76	0.86	69.3	4.49	0.66	0.77	0.87	66.9	5.09	0.67	0.78	0.88
67°F	2000	66	3.44	0.53	0.59	0.67	64.3	3.91	0.53	0.6	0.67	62.5	4.44	0.53	0.6	0.68	61.3	5.03	0.53	0.6	0.68
	2500	72.1	3.45	0.53	0.61	0.69	70.3	3.96	0.53	0.61	0.7	68.2	4.49	0.53	0.62	0.71	66	5.08	0.54	0.62	0.72
	3000	77.5	3.48	0.53	0.62	0.72	74.9	3.98	0.54	0.63	0.73	72.6	4.53	0.54	0.64	0.74	70.3	5.13	0.54	0.64	0.75
71°F	2000	69	3.44	0.43	0.5	0.57	67.7	3.94	0.42	0.5	0.57	66.1	4.48	0.42	0.5	0.58	63.4	5.06	0.42	0.51	0.58
	2500	76.2	3.47	0.42	0.51	0.58	74	3.98	0.42	0.51	0.58	71.7	4.51	0.42	0.51	0.59	69.1	5.11	0.42	0.52	0.6
	3000	80.6	3.47	0.42	0.52	0.6	78.6	3.99	0.42	0.52	0.61	75.7	4.55	0.42	0.53	0.61	73.3	5.16	0.42	0.53	0.62

25 TON HIGH EFFICIENCY LGT302H5V (2 COMPRESSORS - PART LOAD) - VARIABLE AIR VOLUME

Entering Wet Bulb Temperature	Total Air Volume	Outdoor Air Temperature Entering Outdoor Coil																			
		85°F					95°F					105°F					115°F				
		Total Cool Cap.	Comp. Motor Input	Sensible To Total Ratio (S/T)			Total Cool Cap.	Comp. Motor Input	Sensible To Total Ratio (S/T)			Total Cool Cap.	Comp. Motor Input	Sensible To Total Ratio (S/T)			Total Cool Cap.	Comp. Motor Input	Sensible To Total Ratio (S/T)		
				Dry Bulb					Dry Bulb					Dry Bulb					Dry Bulb		
cfm	kBtuh	kW	75°F	80°F	85°F	kBtuh	kW	75°F	80°F	85°F	kBtuh	kW	75°F	80°F	85°F	kBtuh	kW	75°F	80°F	85°F	
63°F	4000	161.9	6.75	0.69	0.81	0.92	156.9	7.79	0.7	0.82	0.94	151.4	8.89	0.7	0.83	0.96	145.7	10.1	0.72	0.85	0.98
	5000	171	6.76	0.72	0.86	0.99	165.6	7.82	0.73	0.88	1	159.6	8.94	0.74	0.89	1	153.3	10.16	0.76	0.92	1
	6000	178	6.76	0.76	0.92	1	171.9	7.83	0.77	0.94	1	165.5	8.98	0.79	0.96	1	158.8	10.21	0.81	0.98	1
67°F	4000	170	6.76	0.55	0.67	0.77	164.7	7.82	0.56	0.67	0.78	158.8	8.94	0.57	0.68	0.8	153	10.16	0.58	0.69	0.81
	5000	179.8	6.76	0.58	0.7	0.83	173.7	7.84	0.58	0.71	0.85	167.6	8.99	0.59	0.72	0.86	161	10.23	0.6	0.74	0.89
	6000	186.8	6.75	0.59	0.74	0.89	180.3	7.86	0.6	0.75	0.9	173.6	9.02	0.61	0.77	0.93	166	10.27	0.63	0.79	0.95
71°F	4000	177.6	6.76	0.44	0.54	0.65	171.8	7.83	0.44	0.55	0.65	166	8.98	0.44	0.56	0.66	159.4	10.21	0.45	0.56	0.67
	5000	187.7	6.75	0.45	0.57	0.68	182.2	7.86	0.45	0.57	0.69	175.2	9.03	0.45	0.58	0.71	168.3	10.29	0.45	0.59	0.72
	6000	195.9	6.75	0.45	0.58	0.72	189	7.87	0.45	0.59	0.73	181.4	9.06	0.45	0.6	0.75	173.5	10.33	0.46	0.62	0.77

RATINGS

NOTE – For Temperatures and Capacities not shown in tables, see bulletin – Cooling Unit Rating Table Correction Factor Data in Miscellaneous Engineering Data section.

25 TON HIGH EFFICIENCY LGT302H5V (3 COMPRESSORS - PART LOAD) - VARIABLE AIR VOLUME

Entering Wet Bulb Temperature	Total Air Volume	Outdoor Air Temperature Entering Outdoor Coil																			
		65°F					75°F					85°F					95°F				
		Total Cool Cap.	Comp. Motor Input	Sensible To Total Ratio (S/T)			Total Cool Cap.	Comp. Motor Input	Sensible To Total Ratio (S/T)			Total Cool Cap.	Comp. Motor Input	Sensible To Total Ratio (S/T)			Total Cool Cap.	Comp. Motor Input	Sensible To Total Ratio (S/T)		
				Dry Bulb					Dry Bulb					Dry Bulb					Dry Bulb		
cfm	kBtuh	kW	75°F	80°F	85°F	kBtuh	kW	75°F	80°F	85°F	kBtuh	kW	75°F	80°F	85°F	kBtuh	kW	75°F	80°F	85°F	
63°F	6000	244.8	10.08	0.71	0.82	0.91	236.8	11.63	0.71	0.83	0.91	228.5	13.25	0.72	0.84	0.92	219.5	15.15	0.73	0.86	0.93
	7500	257	10.05	0.74	0.87	0.94	248.7	11.66	0.75	0.89	0.94	240.8	13.35	0.76	0.89	0.95	230.5	15.14	0.78	0.9	0.96
	9000	268.4	10.05	0.79	0.9	0.96	260	11.69	0.8	0.91	0.97	251.1	13.39	0.81	0.92	0.98	240.1	15.21	0.83	0.93	0.99
67°F	6000	258.3	10.05	0.57	0.68	0.79	249.8	11.63	0.57	0.69	0.8	240	13.32	0.58	0.7	0.82	230.7	15.14	0.58	0.71	0.83
	7500	271.4	10.07	0.59	0.72	0.85	261.4	11.68	0.59	0.73	0.86	251.7	13.38	0.61	0.74	0.87	240.8	15.23	0.61	0.75	0.88
	9000	280.3	10.06	0.61	0.76	0.89	269.8	11.69	0.63	0.77	0.9	258.5	13.43	0.64	0.79	0.91	248.2	15.28	0.64	0.8	0.92
71°F	6000	272.2	10.05	0.44	0.56	0.66	263.6	11.69	0.44	0.56	0.67	254	13.42	0.43	0.56	0.68	243.5	15.24	0.44	0.57	0.69
	7500	286.3	10.06	0.44	0.57	0.69	276	11.72	0.45	0.58	0.7	265.3	13.46	0.45	0.59	0.72	254	15.34	0.46	0.6	0.73
	9000	295.5	10.03	0.46	0.6	0.74	283.8	11.71	0.45	0.61	0.75	272.4	13.48	0.46	0.63	0.77	261.1	15.37	0.46	0.63	0.79

25 TON HIGH EFFICIENCY LGT302H5V (4 COMPRESSORS - FULL LOAD) - VARIABLE AIR VOLUME

Entering Wet Bulb Temperature	Total Air Volume	Outdoor Air Temperature Entering Outdoor Coil																			
		65°F					75°F					85°F					95°F				
		Total Cool Cap.	Comp. Motor Input	Sensible To Total Ratio (S/T)			Total Cool Cap.	Comp. Motor Input	Sensible To Total Ratio (S/T)			Total Cool Cap.	Comp. Motor Input	Sensible To Total Ratio (S/T)			Total Cool Cap.	Comp. Motor Input	Sensible To Total Ratio (S/T)		
				Dry Bulb					Dry Bulb					Dry Bulb					Dry Bulb		
cfm	kBtuh	kW	75°F	80°F	85°F	kBtuh	kW	75°F	80°F	85°F	kBtuh	kW	75°F	80°F	85°F	kBtuh	kW	75°F	80°F	85°F	
63°F	8000	311.7	17.95	0.72	0.83	0.93	299.5	20.37	0.73	0.85	0.95	287.3	23.02	0.74	0.86	0.96	274.4	26.02	0.75	0.88	0.98
	10000	327.7	18.04	0.77	0.89	0.99	314.6	20.51	0.78	0.91	1	301.5	23.19	0.8	0.92	1	288	26.18	0.82	0.94	1
	12000	339	18.1	0.81	0.94	1	325.6	20.6	0.84	0.96	1	312.1	23.32	0.85	0.98	1	297.8	26.31	0.86	1	1
67°F	8000	326.9	18.02	0.57	0.69	0.81	312.7	20.47	0.57	0.71	0.82	299.4	23.19	0.59	0.72	0.84	284.5	26.12	0.6	0.73	0.86
	10000	337.9	18.1	0.61	0.74	0.87	324.3	20.59	0.61	0.76	0.89	309.7	23.29	0.63	0.78	0.9	294.1	26.23	0.64	0.81	0.92
	12000	347.6	18.16	0.64	0.8	0.92	332.6	20.65	0.65	0.81	0.94	318.1	23.37	0.65	0.84	0.96	303.2	26.35	0.66	0.86	0.98
71°F	8000	344.2	18.14	0.43	0.56	0.66	330.6	20.64	0.44	0.56	0.68	315.3	23.35	0.44	0.57	0.69	299.6	26.31	0.44	0.58	0.71
	10000	355.9	18.2	0.45	0.6	0.72	340.9	20.72	0.46	0.59	0.74	325.2	23.45	0.45	0.61	0.75	309.1	26.43	0.47	0.62	0.77
	12000	364.5	18.24	0.45	0.62	0.77	348.9	20.79	0.46	0.63	0.8	332.5	23.52	0.46	0.65	0.81	316.2	26.52	0.47	0.66	0.83

30 TON HIGH EFFICIENCY LGT360H5M (3 COMPRESSORS OPERATING) - MSAV® MULTI-STAGE AIR VOLUME

Entering Wet Bulb Temperature	Total Air Volume	Outdoor Air Temperature Entering Outdoor Coil																			
		65°F					75°F					85°F					95°F				
		Total Cool Cap.	Comp. Motor Input	Sensible To Total Ratio (S/T)			Total Cool Cap.	Comp. Motor Input	Sensible To Total Ratio (S/T)			Total Cool Cap.	Comp. Motor Input	Sensible To Total Ratio (S/T)			Total Cool Cap.	Comp. Motor Input	Sensible To Total Ratio (S/T)		
				Dry Bulb					Dry Bulb					Dry Bulb					Dry Bulb		
cfm	kBtuh	kW	75°F	80°F	85°F	kBtuh	kW	75°F	80°F	85°F	kBtuh	kW	75°F	80°F	85°F	kBtuh	kW	75°F	80°F	85°F	
63°F	4800	196.2	9.17	0.71	0.82	0.93	187.1	10.38	0.71	0.83	0.94	178.5	11.7	0.72	0.84	0.96	169.2	13.14	0.73	0.86	0.98
	6000	207.1	9.26	0.74	0.87	0.99	197.9	10.48	0.75	0.89	1	188.6	11.82	0.76	0.9	1	178.8	13.27	0.77	0.92	1
	7200	215.7	9.32	0.78	0.93	1	206.1	10.56	0.79	0.94	1	196	11.91	0.8	0.96	1	185.4	13.37	0.82	0.98	1
67°F	4800	206	9.25	0.57	0.68	0.79	197.4	10.48	0.57	0.69	0.8	188.4	11.81	0.57	0.7	0.81	178.9	13.28	0.58	0.7	0.83
	6000	218.6	9.35	0.59	0.72	0.85	208.5	10.58	0.6	0.73	0.86	198	11.93	0.6	0.74	0.87	188.6	13.41	0.61	0.75	0.89
	7200	227.4	9.41	0.62	0.76	0.9	216.7	10.67	0.63	0.77	0.91	205.4	12.02	0.62	0.79	0.93	195.6	13.51	0.62	0.8	0.96
71°F	4800	216.4	9.33	0.45	0.56	0.66	207.4	10.57	0.44	0.56	0.67	197.6	11.93	0.44	0.56	0.68	187.7	13.39	0.42	0.56	0.68
	6000	229.4	9.43	0.44	0.58	0.7	218.5	10.69	0.46	0.59	0.71	208.4	12.05	0.43	0.59	0.72	198	13.55	0.46	0.6	0.74
	7200	238.1	9.49	0.47	0.61	0.74	227.6	10.77	0.47	0.61	0.75	215.8	12.14	0.45	0.62	0.77	205.1	13.64	0.47	0.62	0.79

30 TON HIGH EFFICIENCY LGT360H5M (ALL COMPRESSORS OPERATING) - MSAV® MULTI-STAGE AIR VOLUME

Entering Wet Bulb Temperature	Total Air Volume	Outdoor Air Temperature Entering Outdoor Coil																			
		85°F					95°F					105°F					115°F				
		Total Cool Cap.	Comp. Motor Input	Sensible To Total Ratio (S/T)			Total Cool Cap.	Comp. Motor Input	Sensible To Total Ratio (S/T)			Total Cool Cap.	Comp. Motor Input	Sensible To Total Ratio (S/T)			Total Cool Cap.	Comp. Motor Input	Sensible To Total Ratio (S/T)		
				Dry Bulb					Dry Bulb					Dry Bulb					Dry Bulb		
cfm	kBtuh	kW	75°F	80°F	85°F	kBtuh	kW	75°F	80°F	85°F	kBtuh	kW	75°F	80°F	85°F	kBtuh	kW	75°F	80°F	85°F	
63°F	9600	383.1	24.11	0.74	0.86	0.95	363.6	27.05	0.74	0.88	0.96	344.7	30.4	0.75	0.89	0.98	323.2	33.91	0.77	0.9	0.99
	12000	404.7	24.34	0.8	0.91	1	384.7	27.35	0.81	0.93	1	362.5	30.6	0.82	0.94	1	340.6	34.21	0.84	0.96	1
	14400	420.8	24.53	0.84	0.96	1	400	27.56	0.86	0.97	1	377.5	30.85	0.87	0.99	1	353.8	34.43	0.89	1	1
67°F	9600	403.9	24.34	0.58	0.72	0.84	383.4	27.33	0.57	0.73	0.85	361.2	30.59	0.59	0.74	0.87	337.4	34.14	0.59	0.75	0.88
	12000	422	24.55	0.61	0.77	0.9	399.9	27.55	0.62	0.78	0.91	376.2	30.83	0.63	0.8	0.92	351	34.38	0.64	0.83	0.94
	14400	435	24.71	0.65	0.83	0.94	411.1	27.71	0.68	0.84	0.96	386.8	30.99	0.68	0.86	0.97	361.6	34.56	0.7	0.88	0.99
71°F	9600	429.1	24.63	0.43	0.56	0.69	407.3	27.65	0.43	0.56	0.7	383.8	30.94	0.42	0.57	0.71	358	34.49	0.44	0.58	0.73
	12000	446.7	24.84	0.45	0.6	0.75	422.5	27.87	0.44	0.61	0.77	396.8	31.15	0.45	0.62	0.79	370.8	34.71	0.45	0.64	0.81
	14400	458.2	24.98	0.47	0.65	0.81	432.7	28.02	0.48	0.66	0.83	406.2	31.29	0.48	0.67	0.85	379.8	34.86	0.49	0.7	0.86

RATINGS

NOTE – For Temperatures and Capacities not shown in tables, see bulletin – Cooling Unit Rating Table Correction Factor Data in Miscellaneous Engineering Data section.

30 TON HIGH EFFICIENCY LGT360H5V (1 COMPRESSOR - PART LOAD) - VARIABLE AIR VOLUME

Entering Wet Bulb Temperature	Total Air Volume	Outdoor Air Temperature Entering Outdoor Coil																			
		65°F					75°F					85°F					95°F				
		Total Cool Cap.	Comp. Motor Input	Sensible To Total Ratio (S/T)			Total Cool Cap.	Comp. Motor Input	Sensible To Total Ratio (S/T)			Total Cool Cap.	Comp. Motor Input	Sensible To Total Ratio (S/T)			Total Cool Cap.	Comp. Motor Input	Sensible To Total Ratio (S/T)		
				Dry Bulb					Dry Bulb					Dry Bulb					Dry Bulb		
cfm	kBtuh	kW	75°F	80°F	85°F	kBtuh	kW	75°F	80°F	85°F	kBtuh	kW	75°F	80°F	85°F	kBtuh	kW	75°F	80°F	85°F	
63°F	2400	75.5	4.46	0.63	0.71	0.79	72	5.03	0.64	0.72	0.8	69	5.67	0.63	0.71	0.8	65.7	6.38	0.63	0.72	0.81
	3000	82.2	4.53	0.65	0.74	0.83	79.1	5.12	0.65	0.74	0.83	75.7	5.77	0.65	0.75	0.84	71.6	6.48	0.65	0.75	0.85
	3600	87.8	4.59	0.66	0.77	0.86	84.6	5.19	0.67	0.77	0.87	80.3	5.83	0.67	0.78	0.88	76.2	6.55	0.67	0.79	0.9
67°F	2400	78.6	4.49	0.54	0.6	0.68	76	5.08	0.52	0.61	0.68	72.7	5.72	0.52	0.61	0.68	68.9	6.43	0.52	0.6	0.68
	3000	86.5	4.57	0.54	0.62	0.71	83.4	5.17	0.54	0.62	0.71	79.8	5.83	0.53	0.63	0.72	75.4	6.54	0.53	0.63	0.72
	3600	92.4	4.63	0.55	0.64	0.74	89.1	5.24	0.55	0.64	0.74	84.2	5.88	0.55	0.65	0.75	80.6	6.62	0.55	0.65	0.76
71°F	2400	82.7	4.53	0.43	0.51	0.58	79.4	5.12	0.42	0.51	0.58	75.6	5.76	0.41	0.5	0.58	72.7	6.49	0.41	0.5	0.58
	3000	90.3	4.61	0.42	0.53	0.6	86.7	5.21	0.42	0.52	0.6	83.1	5.86	0.42	0.52	0.61	79.2	6.59	0.42	0.52	0.61
	3600	96.6	4.67	0.44	0.54	0.62	93.1	5.28	0.42	0.53	0.62	88.8	5.95	0.41	0.53	0.63	84.7	6.68	0.41	0.53	0.63

30 TON HIGH EFFICIENCY LGT360H5V (2 COMPRESSORS - PART LOAD) - VARIABLE AIR VOLUME

Entering Wet Bulb Temperature	Total Air Volume	Outdoor Air Temperature Entering Outdoor Coil																			
		65°F					75°F					85°F					95°F				
		Total Cool Cap.	Comp. Motor Input	Sensible To Total Ratio (S/T)			Total Cool Cap.	Comp. Motor Input	Sensible To Total Ratio (S/T)			Total Cool Cap.	Comp. Motor Input	Sensible To Total Ratio (S/T)			Total Cool Cap.	Comp. Motor Input	Sensible To Total Ratio (S/T)		
				Dry Bulb					Dry Bulb					Dry Bulb					Dry Bulb		
cfm	kBtuh	kW	75°F	80°F	85°F	kBtuh	kW	75°F	80°F	85°F	kBtuh	kW	75°F	80°F	85°F	kBtuh	kW	75°F	80°F	85°F	
63°F	4800	196.2	9.17	0.71	0.82	0.93	187.1	10.38	0.71	0.83	0.94	178.5	11.7	0.72	0.84	0.96	169.2	13.14	0.73	0.86	0.98
	6000	207.1	9.26	0.74	0.87	0.99	197.9	10.48	0.75	0.89	1	188.6	11.82	0.76	0.9	1	178.8	13.27	0.77	0.92	1
	7200	215.7	9.32	0.78	0.93	1	206.1	10.56	0.79	0.94	1	196	11.91	0.8	0.96	1	185.4	13.37	0.82	0.98	1
67°F	4800	206	9.25	0.57	0.68	0.79	197.4	10.48	0.57	0.69	0.8	188.4	11.81	0.57	0.7	0.81	178.9	13.28	0.58	0.7	0.83
	6000	218.6	9.35	0.59	0.72	0.85	208.5	10.58	0.6	0.73	0.86	198	11.93	0.6	0.74	0.87	188.6	13.41	0.61	0.75	0.89
	7200	227.4	9.41	0.62	0.76	0.9	216.7	10.67	0.63	0.77	0.91	205.4	12.02	0.62	0.79	0.93	195.6	13.51	0.62	0.8	0.96
71°F	4800	216.4	9.33	0.45	0.56	0.66	207.4	10.57	0.44	0.56	0.67	197.6	11.93	0.44	0.56	0.68	187.7	13.39	0.42	0.56	0.68
	6000	229.4	9.43	0.44	0.58	0.7	218.5	10.69	0.46	0.59	0.71	208.4	12.05	0.43	0.59	0.72	198	13.55	0.46	0.6	0.74
	7200	238.1	9.49	0.47	0.61	0.74	227.6	10.77	0.47	0.61	0.75	215.8	12.14	0.45	0.62	0.77	205.1	13.64	0.47	0.62	0.79

30 TON HIGH EFFICIENCY LGT360H5V (4 COMPRESSORS - PART LOAD) - VARIABLE AIR VOLUME

Entering Wet Bulb Temperature	Total Air Volume	Outdoor Air Temperature Entering Outdoor Coil																			
		65°F					75°F					85°F					95°F				
		Total Cool Cap.	Comp. Motor Input	Sensible To Total Ratio (S/T)			Total Cool Cap.	Comp. Motor Input	Sensible To Total Ratio (S/T)			Total Cool Cap.	Comp. Motor Input	Sensible To Total Ratio (S/T)			Total Cool Cap.	Comp. Motor Input	Sensible To Total Ratio (S/T)		
				Dry Bulb					Dry Bulb					Dry Bulb					Dry Bulb		
cfm	kBtuh	kW	75°F	80°F	85°F	kBtuh	kW	75°F	80°F	85°F	kBtuh	kW	75°F	80°F	85°F	kBtuh	kW	75°F	80°F	85°F	
63°F	7200	309.2	14.07	0.74	0.85	0.93	296.4	15.94	0.75	0.86	0.93	282.9	17.98	0.75	0.87	0.94	267	20.16	0.76	0.88	0.94
	9000	325.7	14.22	0.78	0.89	0.95	311.6	16.1	0.79	0.9	0.96	296.8	18.17	0.79	0.92	0.96	282.1	20.38	0.8	0.92	0.97
	10800	338.8	14.33	0.81	0.93	0.98	324.3	16.23	0.82	0.93	0.98	309.7	18.32	0.83	0.94	0.99	294.4	20.57	0.84	0.95	1
67°F	7200	327.3	14.23	0.6	0.72	0.82	313.7	16.12	0.6	0.72	0.83	298.8	18.19	0.59	0.73	0.84	283.7	20.41	0.59	0.74	0.85
	9000	343.8	14.37	0.63	0.75	0.87	327.9	16.27	0.62	0.77	0.88	312.3	18.35	0.62	0.78	0.89	296.1	20.6	0.63	0.79	0.9
	10800	354.9	14.47	0.64	0.8	0.91	339	16.4	0.64	0.81	0.92	322.9	18.5	0.65	0.82	0.93	305.6	20.74	0.66	0.83	0.94
71°F	7200	345.2	14.39	0.47	0.58	0.69	330.5	16.29	0.46	0.57	0.7	315.5	18.4	0.44	0.57	0.71	299.6	20.65	0.43	0.58	0.71
	9000	363	14.54	0.46	0.6	0.73	346.9	16.49	0.45	0.61	0.75	330.6	18.59	0.45	0.6	0.76	313.2	20.85	0.44	0.61	0.77
	10800	374.7	14.63	0.47	0.62	0.78	357.9	16.6	0.46	0.63	0.79	340.7	18.72	0.46	0.64	0.8	322.7	21	0.46	0.65	0.81

30 TON HIGH EFFICIENCY LGT360H5V (4 COMPRESSORS - FULL LOAD) - VARIABLE AIR VOLUME

Entering Wet Bulb Temperature	Total Air Volume	Outdoor Air Temperature Entering Outdoor Coil																			
		85°F					95°F					105°F					115°F				
		Total Cool Cap.	Comp. Motor Input	Sensible To Total Ratio (S/T)			Total Cool Cap.	Comp. Motor Input	Sensible To Total Ratio (S/T)			Total Cool Cap.	Comp. Motor Input	Sensible To Total Ratio (S/T)			Total Cool Cap.	Comp. Motor Input	Sensible To Total Ratio (S/T)		
				Dry Bulb					Dry Bulb					Dry Bulb					Dry Bulb		
cfm	kBtuh	kW	75°F	80°F	85°F	kBtuh	kW	75°F	80°F	85°F	kBtuh	kW	75°F	80°F	85°F	kBtuh	kW	75°F	80°F	85°F	
63°F	9600	383.1	24.11	0.74	0.86	0.95	363.6	27.05	0.74	0.88	0.96	344.7	30.4	0.75	0.89	0.98	323.2	33.91	0.77	0.9	0.99
	12000	404.7	24.34	0.8	0.91	1	384.7	27.35	0.81	0.93	1	362.5	30.6	0.82	0.94	1	340.6	34.21	0.84	0.96	1
	14400	420.8	24.53	0.84	0.96	1	400	27.56	0.86	0.97	1	377.5	30.85	0.87	0.99	1	353.8	34.43	0.89	1	1
67°F	9600	403.9	24.34	0.58	0.72	0.84	383.4	27.33	0.57	0.73	0.85	361.2	30.59	0.59	0.74	0.87	337.4	34.14	0.59	0.75	0.88
	12000	422	24.55	0.61	0.77	0.9	399.9	27.55	0.62	0.78	0.91	376.2	30.83	0.63	0.8	0.92	351	34.38	0.64	0.83	0.94
	14400	435	24.71	0.65	0.83	0.94	411.1	27.71	0.68	0.84	0.96	386.8	30.99	0.68	0.86	0.97	361.6	34.56	0.7	0.88	0.99
71°F	9600	429.1	24.63	0.43	0.56	0.69	407.3	27.65	0.43	0.56	0.7	383.8	30.94	0.42	0.57	0.71	358	34.49	0.44	0.58	0.73
	12000	446.7	24.84	0.45	0.6	0.75	422.5	27.87	0.44	0.61	0.77	396.8	31.15	0.45	0.62	0.79	370.8	34.71	0.45	0.64	0.81
	14400	458.2	24.98	0.47	0.65	0.81	432.7	28.02	0.48	0.66	0.83	406.2	31.29	0.48	0.67	0.85	379.8	34.86	0.49	0.7	0.86

HUMIDITROL® DEHUMIDIFICATION SYSTEM RATINGS

25 TON HIGH EFFICIENCY LGT302H5M WITH HUMIDITROL® OPERATING (1ST STAGE)

Entering Wet Bulb Temperature	Total Air Volume	Outdoor Air Temperature Entering Outdoor Coil																			
		65°F					75°F					85°F					95°F				
		Total Cool Cap.	Comp. Motor Input	Sensible To Total Ratio (S/T)			Total Cool Cap.	Comp. Motor Input	Sensible To Total Ratio (S/T)			Total Cool Cap.	Comp. Motor Input	Sensible To Total Ratio (S/T)			Total Cool Cap.	Comp. Motor Input	Sensible To Total Ratio (S/T)		
				Dry Bulb					Dry Bulb					Dry Bulb					Dry Bulb		
cfm	kBtuh	kW	75°F	80°F	85°F	kBtuh	kW	75°F	80°F	85°F	kBtuh	kW	75°F	80°F	85°F	kBtuh	kW	75°F	80°F	85°F	
63°F	4000	78.6	8.24	0.48	0.72	0.94	57.1	8.89	0.37	0.71	1.00	35.4	9.59	0.12	0.69	1.00	13.6	10.40	-1.15	0.62	1.00
	5000	90.9	8.28	0.57	0.82	1.00	67.7	8.95	0.51	0.85	1.00	44.3	9.69	0.38	0.91	1.00	20.8	10.50	-0.12	1.00	1.00
	6000	100.5	8.31	0.65	0.91	1.00	75.7	9.00	0.62	0.97	1.00	50.8	9.75	0.56	1.00	1.00	25.9	10.58	0.33	1.00	1.00
67°F	4000	92.6	8.31	0.25	0.48	0.68	71.1	8.98	0.10	0.41	0.67	49.3	9.71	-0.17	0.27	0.64	27.4	10.53	-0.97	-0.10	0.59
	5000	105.8	8.33	0.32	0.57	0.78	82.5	9.02	0.21	0.53	0.79	59.0	9.78	0.00	0.44	0.81	35.1	10.62	-0.54	0.25	0.87
	6000	115.8	8.33	0.39	0.65	0.86	90.9	9.06	0.29	0.62	0.89	65.6	9.83	0.12	0.58	0.95	40.1	10.69	-0.30	0.48	1.00
71°F	4000	106.6	8.37	0.10	0.30	0.48	84.7	9.06	-0.07	0.20	0.43	63.0	9.82	-0.35	0.02	0.33	42.4	10.66	-0.95	-0.35	0.15
	5000	121.8	8.38	0.17	0.36	0.57	98.4	9.10	0.02	0.27	0.53	74.5	9.88	-0.23	0.14	0.48	50.1	10.73	-0.73	-0.13	0.37
	6000	131.7	8.37	0.19	0.42	0.63	106.9	9.11	0.06	0.35	0.62	81.4	9.91	-0.16	0.23	0.58	55.5	10.79	-0.61	0.02	0.53

25 TON HIGH EFFICIENCY LGT302H5M WITH HUMIDITROL® OPERATING (2ND STAGE)

Entering Wet Bulb Temperature	Total Air Volume	Outdoor Air Temperature Entering Outdoor Coil																			
		65°F					75°F					85°F					95°F				
		Total Cool Cap.	Comp. Motor Input	Sensible To Total Ratio (S/T)			Total Cool Cap.	Comp. Motor Input	Sensible To Total Ratio (S/T)			Total Cool Cap.	Comp. Motor Input	Sensible To Total Ratio (S/T)			Total Cool Cap.	Comp. Motor Input	Sensible To Total Ratio (S/T)		
				Dry Bulb					Dry Bulb					Dry Bulb					Dry Bulb		
cfm	kBtuh	kW	75°F	80°F	85°F	kBtuh	kW	75°F	80°F	85°F	kBtuh	kW	75°F	80°F	85°F	kBtuh	kW	75°F	80°F	85°F	
63°F	8000	235.5	14.49	0.58	0.75	0.89	203.2	16.18	0.56	0.76	0.91	168.4	18.08	0.53	0.77	0.95	135.0	20.16	0.49	0.79	1.00
	10,000	259.7	14.51	0.66	0.83	0.96	224.1	16.29	0.66	0.85	0.99	187.5	18.22	0.65	0.87	1.00	149.9	20.33	0.65	0.91	1.00
	12,000	276.6	14.57	0.73	0.89	1.00	240.3	16.37	0.73	0.91	1.00	201.8	18.32	0.73	0.95	1.00	163.7	20.42	0.75	1.00	1.00
67°F	8000	263.6	14.54	0.40	0.57	0.72	229.4	16.32	0.36	0.54	0.72	192.5	18.27	0.32	0.52	0.73	157.2	20.34	0.22	0.51	0.75
	10,000	282.2	14.59	0.46	0.64	0.80	244.1	16.40	0.43	0.63	0.82	206.7	18.35	0.39	0.63	0.83	167.2	20.51	0.33	0.62	0.86
	12,000	295.3	14.63	0.50	0.70	0.86	256.8	16.47	0.47	0.72	0.88	217.1	18.43	0.43	0.72	0.91	176.4	20.57	0.38	0.74	0.95
71°F	8000	293.3	14.63	0.25	0.41	0.55	258.3	16.44	0.20	0.36	0.54	221.3	18.40	0.13	0.32	0.51	183.5	20.54	0.03	0.27	0.49
	10,000	310.9	14.65	0.29	0.46	0.62	272.6	16.52	0.24	0.44	0.62	233.5	18.51	0.18	0.40	0.61	194.4	20.66	0.08	0.36	0.62
	12,000	323.4	14.67	0.33	0.51	0.69	283.6	16.59	0.27	0.48	0.69	242.5	18.59	0.21	0.46	0.70	202.5	20.77	0.09	0.43	0.70

30 TON HIGH EFFICIENCY LGT360H5M WITH HUMIDITROL® OPERATING (1ST STAGE)

Entering Wet Bulb Temperature	Total Air Volume	Outdoor Air Temperature Entering Outdoor Coil																			
		65°F					75°F					85°F					95°F				
		Total Cool Cap.	Comp. Motor Input	Sensible To Total Ratio (S/T)			Total Cool Cap.	Comp. Motor Input	Sensible To Total Ratio (S/T)			Total Cool Cap.	Comp. Motor Input	Sensible To Total Ratio (S/T)			Total Cool Cap.	Comp. Motor Input	Sensible To Total Ratio (S/T)		
				Dry Bulb					Dry Bulb					Dry Bulb					Dry Bulb		
cfm	kBtuh	kW	75°F	80°F	85°F	kBtuh	kW	75°F	80°F	85°F	kBtuh	kW	75°F	80°F	85°F	kBtuh	kW	75°F	80°F	85°F	
63°F	4800	88.3	11.38	0.42	0.68	0.92	64.3	12.09	0.29	0.64	0.97	41.7	12.87	0.01	0.58	1.00	19.3	13.80	-1.06	0.37	1.00
	6000	99.7	11.61	0.53	0.80	1.00	74.4	12.31	0.44	0.82	1.00	49.0	13.15	0.27	0.84	1.00	25.2	14.08	-0.27	0.93	1.00
	7200	108.1	11.78	0.62	0.91	1.00	81.8	12.49	0.57	0.96	1.00	54.7	13.33	0.46	1.00	1.00	28.4	14.32	0.17	1.00	1.00
67°F	4800	103.7	11.63	0.21	0.44	0.65	80.0	12.34	0.04	0.34	0.62	56.1	13.19	-0.27	0.17	0.57	33.9	14.12	-1.06	-0.21	0.46
	6000	115.6	11.86	0.29	0.53	0.76	90.7	12.57	0.16	0.47	0.77	65.1	13.42	-0.11	0.36	0.77	38.8	14.42	-0.71	0.12	0.80
	7200	124.3	12.03	0.35	0.62	0.87	98.3	12.74	0.24	0.58	0.89	71.0	13.61	0.03	0.52	0.95	43.1	14.64	-0.47	0.37	1.00
71°F	4800	117.9	11.88	0.04	0.25	0.45	94.6	12.60	-0.14	0.13	0.37	70.5	13.45	-0.47	-0.07	0.26	46.7	14.43	-1.10	-0.48	0.04
	6000	130.8	12.10	0.10	0.33	0.53	105.4	12.82	-0.06	0.23	0.48	79.5	13.69	-0.34	0.07	0.41	52.9	14.74	-0.92	-0.27	0.27
	7200	139.8	12.26	0.15	0.39	0.61	113.0	13.00	-0.01	0.30	0.58	85.7	13.88	-0.25	0.17	0.54	56.9	14.94	-0.78	-0.10	0.46

30 TON HIGH EFFICIENCY LGT360H5M WITH HUMIDITROL® OPERATING (2ND STAGE)

Entering Wet Bulb Temperature	Total Air Volume	Outdoor Air Temperature Entering Outdoor Coil																			
		65°F					75°F					85°F					95°F				
		Total Cool Cap.	Comp. Motor Input	Sensible To Total Ratio (S/T)			Total Cool Cap.	Comp. Motor Input	Sensible To Total Ratio (S/T)			Total Cool Cap.	Comp. Motor Input	Sensible To Total Ratio (S/T)			Total Cool Cap.	Comp. Motor Input	Sensible To Total Ratio (S/T)		
				Dry Bulb					Dry Bulb					Dry Bulb					Dry Bulb		
cfm	kBtuh	kW	75°F	80°F	85°F	kBtuh	kW	75°F	80°F	85°F	kBtuh	kW	75°F	80°F	85°F	kBtuh	kW	75°F	80°F	85°F	
63°F	9600	264.2	20.32	0.58	0.77	0.91	218.5	22.08	0.57	0.80	0.96	172.7	24.09	0.56	0.84	1.00	127.1	26.40	0.54	0.90	1.00
	12,000	292.4	20.63	0.66	0.84	0.98	244.6	22.41	0.66	0.88	1.00	196.1	24.50	0.69	0.93	1.00	148.0	26.82	0.70	1.00	1.00
	14,400	314.3	20.86	0.73	0.91	1.00	263.8	22.69	0.74	0.96	1.00	213.3	24.80	0.77	1.00	1.00	163.1	27.13	0.84	1.00	1.00
67°F	9600	298.0	20.66	0.40	0.56	0.73	251.2	22.44	0.35	0.56	0.75	203.8	24.52	0.29	0.54	0.78	156.4	26.86	0.20	0.53	0.83
	12,000	322.1	20.93	0.45	0.64	0.81	272.0	22.76	0.42	0.64	0.84	222.0	24.88	0.38	0.65	0.88	171.4	27.20	0.30	0.67	0.94
	14,400	339.4	21.14	0.49	0.71	0.87	287.9	23.00	0.46	0.72	0.91	235.8	25.16	0.44	0.74	0.97	184.2	27.48	0.39	0.78	1.00
71°F	9600	334.8	21.01	0.24	0.40	0.55	287.0	22.87	0.18	0.36	0.53	239.4	25.02	0.10	0.32	0.53	190.3	27.35	-0.01	0.26	0.50
	12,000	358.8	21.28	0.27	0.45	0.61	308.3	23.16	0.23	0.44	0.62	256.9	25.36	0.14	0.39	0.64	206.3	27.69	0.04	0.34	0.64
	14,400	376.3	21.47	0.30	0.49	0.69	324.8	23.39	0.25	0.47	0.70	270.0	25.57	0.18	0.46	0.72	216.5	27.94	0.08	0.43	0.73

BLOWER DATA

BLOWER TABLE INCLUDES RESISTANCE FOR BASE UNIT ONLY WITH DRY INDOOR COIL & AIR FILTERS IN PLACE FOR ALL UNITS ADD:

- 1 - Wet indoor coil air resistance of selected unit.
- 2 - Any factory installed options air resistance (heat section, economizer, etc.)
- 3 - Any field installed accessories air resistance (duct resistance, diffuser, etc.)

Then determine from blower table blower motor output and drive required.

See page 35 for wet coil and option/accessory air resistance data.

See page 35 for factory installed drive kit specifications.

Air Volume cfm	TOTAL STATIC PRESSURE - In. w.g.																											
	0.20		0.40		0.60		0.80		1.00		1.20		1.40		1.60		1.80		2.00		2.20		2.40		2.60			
	RPM	BHP	RPM	BHP	RPM	BHP	RPM	BHP	RPM	BHP	RPM	BHP	RPM	BHP	RPM	BHP	RPM	BHP	RPM	BHP	RPM	BHP	RPM	BHP	RPM	BHP		
4000	372	0.26	433	0.65	497	0.99	565	1.27	630	1.54	687	1.79	738	2.04	784	2.30	824	2.56	861	2.82	897	3.10	932	3.40	968	3.66	974	4.01
4500	382	0.41	441	0.79	506	1.12	574	1.41	638	1.69	694	1.95	744	2.22	790	2.50	831	2.77	868	3.05	903	3.35	938	3.66	974	3.93	980	4.30
5000	392	0.56	451	0.93	516	1.25	584	1.55	646	1.85	702	2.12	751	2.41	796	2.70	837	3.00	874	3.30	909	3.61	944	3.93	980	4.22	987	4.60
5500	402	0.73	462	1.08	527	1.40	594	1.72	655	2.02	710	2.31	758	2.61	802	2.92	843	3.24	880	3.56	916	3.88	951	4.22	987	4.52	994	4.91
6000	414	0.89	473	1.24	539	1.56	605	1.90	665	2.21	718	2.51	766	2.83	809	3.16	850	3.51	887	3.84	922	4.18	957	4.52	994	4.85	1001	5.24
6500	426	1.07	486	1.41	551	1.74	616	2.10	675	2.42	727	2.73	774	3.07	817	3.43	857	3.80	894	4.15	929	4.49	964	4.85	1001	5.19	1008	5.59
7000	439	1.26	499	1.60	565	1.93	628	2.31	685	2.64	737	2.97	782	3.34	825	3.72	864	4.11	901	4.48	937	4.83	971	5.19	1008	5.56	1016	5.97
7500	453	1.46	513	1.79	579	2.14	641	2.55	696	2.88	747	3.24	792	3.63	833	4.04	872	4.45	909	4.83	945	5.20	979	5.56	1016	5.96	1025	6.37
8000	467	1.66	528	2.00	593	2.38	653	2.81	708	3.15	757	3.53	801	3.95	843	4.39	881	4.82	918	5.22	953	5.59	988	5.96	1025	6.37	1034	6.81
8500	483	1.88	544	2.22	608	2.65	667	3.10	720	3.44	768	3.85	812	4.30	852	4.78	890	5.22	927	5.63	962	6.01	997	6.39	1034	6.81	1044	7.28
9000	499	2.11	561	2.47	624	2.95	681	3.41	733	3.76	780	4.20	823	4.69	862	5.19	900	5.65	936	6.07	972	6.46	1007	6.85	1044	7.28	1055	7.78
9500	516	2.36	578	2.75	640	3.26	696	3.73	746	4.10	792	4.58	834	5.11	873	5.64	910	6.12	946	6.54	982	6.93	1018	7.34	1055	7.78	1066	8.32
10,000	534	2.64	596	3.06	657	3.60	711	4.07	760	4.48	805	5.00	845	5.57	884	6.12	921	6.61	957	7.03	992	7.43	1028	7.86	1066	8.32	1077	8.89
10,500	553	2.93	615	3.39	674	3.95	727	4.44	775	4.90	817	5.46	857	6.06	895	6.62	932	7.12	967	7.55	1003	7.96	1039	8.40	1077	8.89	1089	9.49
11,000	572	3.24	634	3.74	692	4.31	744	4.83	789	5.35	830	5.95	869	6.58	907	7.16	943	7.65	978	8.09	1013	8.51	1050	8.98	1089	9.49	1101	10.12
11,500	592	3.58	653	4.12	711	4.70	760	5.27	803	5.85	843	6.49	881	7.13	918	7.71	954	8.21	989	8.65	1025	9.10	1062	9.59	1101	10.12	1113	10.75
12,000	613	3.95	674	4.53	729	5.14	776	5.75	818	6.39	857	7.06	894	7.71	930	8.30	965	8.80	1000	9.25	1036	9.71	1073	10.22	1113	10.75	1125	11.38
12,500	635	4.37	695	4.98	748	5.62	792	6.29	832	6.98	870	7.67	906	8.33	941	8.91	976	9.42	1011	9.87	1048	10.35	1085	10.75	1125	11.38	1137	12.01
13,000	657	4.83	715	5.50	766	6.18	808	6.89	847	7.61	883	8.32	918	8.98	953	9.56	988	10.06	1023	10.43	1060	10.91	1097	11.37	1137	12.01	1149	12.64
13,500	680	5.35	736	6.06	784	6.78	824	7.53	861	8.29	896	9.00	930	9.66	965	10.24	1000	10.72	1035	11.11	1070	11.69	1107	12.26	1149	12.64	1161	13.27
14,000	704	5.92	757	6.67	801	7.44	839	8.23	875	9.00	909	9.72	943	10.38	978	11.03	1013	11.58	1048	12.01	1083	12.69	1120	13.01	1161	13.27	1173	13.88
14,500	727	6.55	777	7.34	818	8.16	854	8.97	889	9.75	922	10.48	956	11.13	991	11.94	1026	12.43	1061	13.01	1096	13.63	1133	13.91	1173	13.88	1185	14.51
15,000	750	7.23	797	8.07	834	8.92	868	9.75	902	10.54	935	11.37	969	12.17	1004	13.05	1038	13.84	1073	14.43	1108	15.01	1143	15.31	1185	14.51	1197	15.14

BLOWER DATA

DRIVE KIT SPECIFICATIONS

Motor Efficiency	Nominal HP	Maximum HP	Drive Kit Number	RPM Range
Standard	5	5.75	5	660 - 810
Standard	5	5.75	6	770 - 965
Standard	5	5.75	7	570 - 720
Standard	5	5.75	8	480 - 630
Standard	5	5.75	9	410 - 535
Standard	7.5	8.63	3	715 - 880
Standard	7.5	8.63	4	770 - 965
Standard	10	11.50	1	740 - 895
Standard	10	11.50	2	870 - 1045

NOTE - Using total air volume and system static pressure requirements determine from blower performance tables rpm and motor output required. Maximum usable output of motors furnished are shown. In Canada, nominal motor output is also maximum usable motor output. If motors of comparable output are used, be sure to keep within the service factor limitations outlined on the motor nameplate.

For VFD applications, nominal motor output is also maximum usable motor output.

FACTORY INSTALLED OPTIONS/FIELD INSTALLED ACCESSORY AIR RESISTANCE

Air Volume cfm	Wet Indoor Coil in. w.g.	Reheat Coil in. w.g.	Gas Heat Exchanger			Economizer in. w.g.	Filters			Horizontal Roof Curb in. w.g.
			Standard Heat	Medium Heat	High Heat		MERV 8	MERV 13	MERV 16	
			in. w.g.	in. w.g.	in. w.g.		in. w.g.	in. w.g.	in. w.g.	
4000	0.04	0.04	0.08	0.08	0.11	0.00	0.00	0.00	0.06	0.04
4500	0.04	0.04	0.09	0.10	0.13	0.00	0.00	0.00	0.07	0.05
5000	0.05	0.04	0.10	0.12	0.15	0.00	0.00	0.00	0.08	0.06
5500	0.06	0.06	0.11	0.14	0.17	0.01	0.00	0.01	0.09	0.07
6000	0.07	0.06	0.12	0.16	0.19	0.01	0.00	0.02	0.10	0.08
6500	0.08	0.08	0.13	0.18	0.21	0.01	0.01	0.02	0.11	0.09
7000	0.09	0.08	0.14	0.20	0.24	0.02	0.01	0.03	0.12	0.10
7500	0.10	0.10	0.15	0.21	0.25	0.02	0.01	0.04	0.13	0.11
8000	0.11	0.10	0.17	0.24	0.28	0.02	0.01	0.04	0.14	0.13
8500	0.12	0.10	0.20	0.27	0.31	0.03	0.01	0.04	0.15	0.15
9000	0.13	0.12	0.22	0.29	0.34	0.04	0.01	0.04	0.16	0.17
9500	0.14	0.14	0.24	0.32	0.38	0.04	0.02	0.06	0.17	0.19
10,000	0.15	0.16	0.27	0.36	0.42	0.05	0.02	0.06	0.18	0.21
10,500	0.16	0.17	0.30	0.40	0.46	0.06	0.02	0.06	0.19	0.24
11,000	0.18	0.18	0.33	0.43	0.50	0.07	0.02	0.07	0.20	0.27
11,500	0.19	0.19	0.37	0.48	0.55	0.08	0.02	0.08	0.22	0.30
12,000	0.20	0.20	0.40	0.52	0.60	0.10	0.02	0.08	0.23	0.33
12,500	0.21	0.22	0.44	0.57	0.65	0.11	0.03	0.10	0.24	0.37
13,000	0.23	0.23	0.48	0.61	0.70	0.13	0.03	0.10	0.25	0.40
13,500	0.24	0.25	0.53	0.67	0.76	0.14	0.03	0.11	0.26	0.44
14,000	0.26	0.26	0.57	0.72	0.82	0.16	0.03	0.12	0.27	0.49
14,500	0.27	0.27	0.62	0.78	0.89	0.18	0.04	0.13	0.28	0.53
15,000	0.29	0.29	0.68	0.84	0.95	0.21	0.04	0.13	0.29	0.58

BLOWER DATA

POWER EXHAUST PERFORMANCE - STANDARD STATIC

Return Duct Negative Static Pressure	Air Volume Exhausted
in. w.g.	cfm
0.00	12,800
0.05	12,200
0.10	11,500
0.15	10,800
0.20	9900
0.25	9000
0.30	7900
0.35	6750
0.40	5450
0.45	4150
0.50	2900

POWER EXHAUST - HIGH STATIC

Air Volume cfm	Return Duct Negative Static Pressure - In. w.g.																					
	0		0.10		0.20		0.30		0.40		0.50		0.60		0.70		0.80		0.90		1.0	
	RPM	BHP	RPM	BHP	RPM	BHP	RPM	BHP	RPM	BHP	RPM	BHP	RPM	BHP	RPM	BHP	RPM	BHP	RPM	BHP	RPM	BHP
8500	487	0.43	501	0.44	521	0.46	548	0.49	584	0.53	625	0.58	667	0.64	708	0.70	746	0.75	783	0.81	818	0.87
9000	515	0.51	528	0.52	547	0.54	570	0.57	601	0.61	638	0.66	678	0.71	717	0.77	755	0.83	791	0.90	826	0.96
9500	544	0.60	556	0.61	573	0.63	594	0.66	620	0.69	652	0.74	689	0.80	727	0.86	765	0.93	800	0.99	834	1.05
10,000	572	0.70	584	0.71	599	0.73	618	0.76	641	0.79	669	0.83	702	0.89	738	0.95	774	1.02	810	1.09	843	1.15
10,500	601	0.81	612	0.82	626	0.84	643	0.87	663	0.90	688	0.94	718	0.99	750	1.05	785	1.12	819	1.19	853	1.27
11,000	629	0.93	640	0.95	653	0.97	668	0.99	687	1.02	709	1.06	735	1.11	764	1.16	796	1.23	830	1.31	862	1.38
11,500	658	1.06	668	1.08	680	1.10	694	1.12	711	1.15	731	1.19	754	1.24	780	1.29	810	1.36	841	1.43	872	1.50
12,000	686	1.21	696	1.22	707	1.24	721	1.27	736	1.30	754	1.34	774	1.38	798	1.43	825	1.49	853	1.56	883	1.64

BLOWER DATA

CEILING DIFFUSER AIR RESISTANCE - in. w.g.

Air Volume cfm	Step-Down Diffuser			Flush Diffuser
	LARTD30/36S			LAFD30/36S
	2 Ends Open	1 Side/2 Ends Open	All Ends & Sides Open	
7500	0.37	0.31	0.25	0.29
8000	0.42	0.36	0.29	0.34
8500	0.48	0.41	0.34	0.39
9000	0.55	0.47	0.39	0.44
9500	0.62	0.53	0.45	0.51
10,000	0.70	0.60	0.51	0.57
10,500	0.78	0.68	0.58	0.65
11,000	0.87	0.76	0.65	0.72
11,500	0.97	0.85	0.73	0.81
12,000	1.08	0.94	0.82	0.9
12,500	1.19	1.04	0.91	0.99
13,000	1.30	1.15	1.00	1.10
13,500	1.43	1.26	1.10	1.20
14,000	1.56	1.38	1.20	1.31
14,500	1.69	1.50	1.31	1.43
15,000	1.84	1.63	1.43	1.56

CEILING DIFFUSER AIR THROW DATA - ft.

Air Volume cfm	¹ Effective Throw Range - ft.	
	Step-Down	Flush
9000	40 - 47	29 - 35
9500	43 - 50	33 - 41
10,000	46 - 54	37 - 46
10,500	50 - 58	42 - 51
11,000	53 - 61	46 - 56
11,500	55 - 64	50 - 61
12,000	58 - 67	54 - 66
12,500	61 - 71	58 - 71
13,000	64 - 74	62 - 75
13,500	67 - 77	66 - 79

¹ Throw is the horizontal or vertical distance an airstream travels on leaving the outlet or diffuser before the maximum velocity is reduced to 50 ft. per minute. Four sides open.

ELECTRICAL DATA

25 TON

Model No.		LGT302H5M, LGT302H5V								
¹ Voltage - 60hz		208/230V - 3 Ph			460V - 3 Ph			575V - 3 Ph		
Compressor 1	Rated Load Amps	22.4			9.1			7.2		
	Locked Rotor Amps	166.2			74.6			54		
Compressor 2	Rated Load Amps	22.4			9.1			7.2		
	Locked Rotor Amps	166.2			74.6			54		
Compressor 3	Rated Load Amps	22.4			9.1			7.2		
	Locked Rotor Amps	166.2			74.6			54		
Compressor 4	Rated Load Amps	22.4			9.1			7.2		
	Locked Rotor Amps	166.2			74.6			54		
Outdoor Fan Motors (6)	Full Load Amps (6 Non-ECM)	2.4			1.3			1		
	Total	14.4			7.8			6		
Standard Power Exhaust (3) 0.33 HP	Full Load Amps	2.4			1.3			1		
	Total	7.2			3.9			3		
High Static Power Exhaust (3) 2 HP	Full Load Amps	7.5			3.4			2.7		
	Total	22.5			10.2			8.1		
Service Outlet 115V GFI (amps)		15			15			20		
Indoor Blower Motor	HP	5	7.5	10	5	7.5	10	5	7.5	10
	Full Load Amps	16.7	24.2	30.8	7.6	11	14	6.1	9	11
² Maximum Overcurrent Protection	Unit Only	150	150	150	60	60	70	45	50	50
	With (3) 0.33 HP Standard Power Exhaust	150	150	175	60	70	70	50	50	60
	With High Static Power Exhaust (3) 2 HP	150	175	175	70	70	80	60	60	60
³ Minimum Circuit Ampacity	Unit Only	127	135	143	55	58	62	43	47	49
	With (3) 0.33 HP Standard Power Exhaust	134	142	150	58	62	66	46	50	52
	With High Static Power Exhaust (3) 2 HP	149	157	165	65	69	72	51	55	57

ELECTRICAL ACCESSORIES

Disconnect	Unit Only	54W89	54W89	90W82	54W88	54W88	54W88	54W88	54W88	54W88
	Unit + Standard Power Exhaust (3) 0.33 HP	54W89	90W82	90W82	54W88	54W88	54W88	54W88	54W88	54W88
	Unit + High Static Power Exhaust (3) 2 HP	90W82	90W82	90W82	54W88	54W89	54W89	54W88	54W88	54W88
Terminal Block		30K75	30K75	30K75	30K75	30K75	30K75	30K75	30K75	30K75

Disconnects - **54W88** - 80A
54W89 - 150A
90W82 - 250A

NOTE - All units have a minimum Short Circuit Current Rating (SCCR) of 5000 amps.

¹ Extremes of operating range are plus and minus 10% of line voltage.

² HACR type breaker or fuse.

³ Refer to National or Canadian Electrical Code manual to determine wire, fuse and disconnect size requirements.

ELECTRICAL DATA

30 TON

Model No.		LGT360H5M, LGT360H5V								
¹ Voltage - 60hz		208/230V - 3 Ph			460V - 3 Ph			575V - 3 Ph		
Compressor 1	Rated Load Amps	30.9			12.8			10.1		
	Locked Rotor Amps	178.5			103			78		
Compressor 2	Rated Load Amps	30.9			12.8			10.1		
	Locked Rotor Amps	178.5			103			78		
Compressor 3	Rated Load Amps	30.9			12.8			10.1		
	Locked Rotor Amps	178.5			103			78		
Compressor 4	Rated Load Amps	30.9			12.8			10.1		
	Locked Rotor Amps	178.5			103			78		
Outdoor Fan Motors (6)	Full Load Amps (6 Non-ECM)	2.4			1.3			1		
	Total	14.4			7.8			6		
Standard Power Exhaust (3) 0.33 HP	Full Load Amps	2.4			1.3			1		
	Total	7.2			3.9			3		
High Static Power Exhaust (3) 2 HP	Full Load Amps	7.5			3.4			2.7		
	Total	22.5			10.2			8.1		
Service Outlet 115V GFI (amps)		15			15			20		
Indoor Blower Motor	HP	5	7.5	10	5	7.5	10	5	7.5	10
	Full Load Amps	16.7	24.2	30.8	7.6	11	14	6.1	9	11
² Maximum Overcurrent Protection	Unit Only	175	200	⁴ 200	80	80	90	60	60	70
	With (3) 0.33 HP Standard Power Exhaust	⁴ 200	⁴ 200	⁴ 200	80	80	90	60	70	70
	With High Static Power Exhaust (3) 2 HP	⁴ 200	⁴ 200	⁴ 225	90	90	100	70	70	70
³ Minimum Circuit Ampacity	Unit Only	163	170	177	70	74	77	56	58	61
	With (3) 0.33 HP Standard Power Exhaust	170	178	184	74	78	81	59	61	64
	With High Static Power Exhaust (3) 2 HP	185	193	200	80	84	87	64	67	69

ELECTRICAL ACCESSORIES

Disconnect	Unit Only	90W82	90W82	90W82	54W88	54W88	54W89	54W88	54W88	54W88
	Unit + Standard Power Exhaust (3) 0.33 HP	90W82	90W82	90W82	54W88	54W89	54W89	54W88	54W88	54W88
	Unit + High Static Power Exhaust (3) 2 HP	90W82	90W82	90W82	54W89	54W89	54W89	54W88	54W88	54W88
Terminal Block		30K75	30K75	30K75	30K75	30K75	30K75	30K75	30K75	30K75

Disconnects - 54W88 - 80A
 54W89 - 150A
 90W82 - 250A

NOTE - All units have a minimum Short Circuit Current Rating (SCCR) of 5000 amps.

¹ Extremes of operating range are plus and minus 10% of line voltage.

² HACR type breaker or fuse.

³ Refer to National or Canadian Electrical Code manual to determine wire, fuse and disconnect size requirements.

⁴ Factory installed circuit breaker not available.

UNIT CLEARANCES

Unit With Economizer

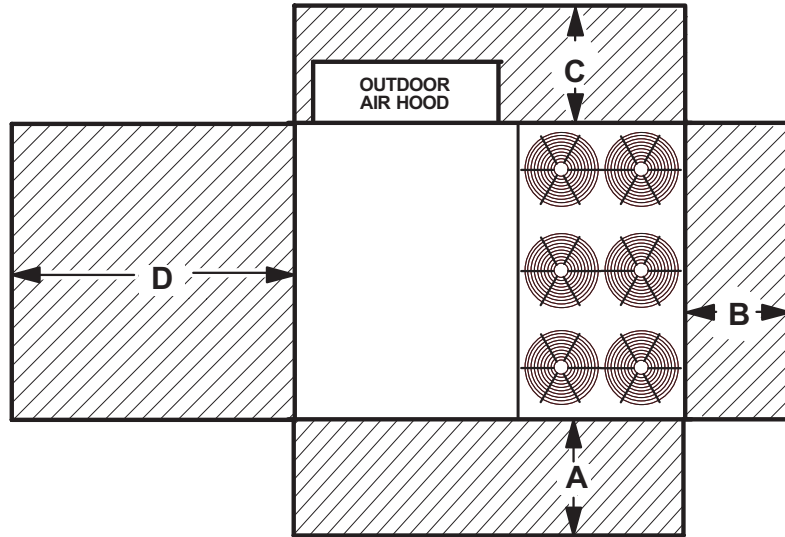

1 Unit Clearance	A		B		C		D		Top Clearance
	in.	mm	in.	mm	in.	mm	in.	mm	
Service Clearance	60	1524	36	914	36	914	66	1676	Unobstructed
Clearance to Combustibles	36	914	1	25	1	25	1	25	
Minimum Operation Clearance	45	1143	36	914	36	914	41	1041	

NOTE - Entire perimeter of unit base requires support when elevated above the mounting surface.

¹ Service Clearance - Required for removal of serviceable parts.

Clearance to Combustibles - Required clearance to combustible material.

Minimum Operation Clearance - Required clearance for proper unit operation.

Unit With High Static Power Exhaust Fans

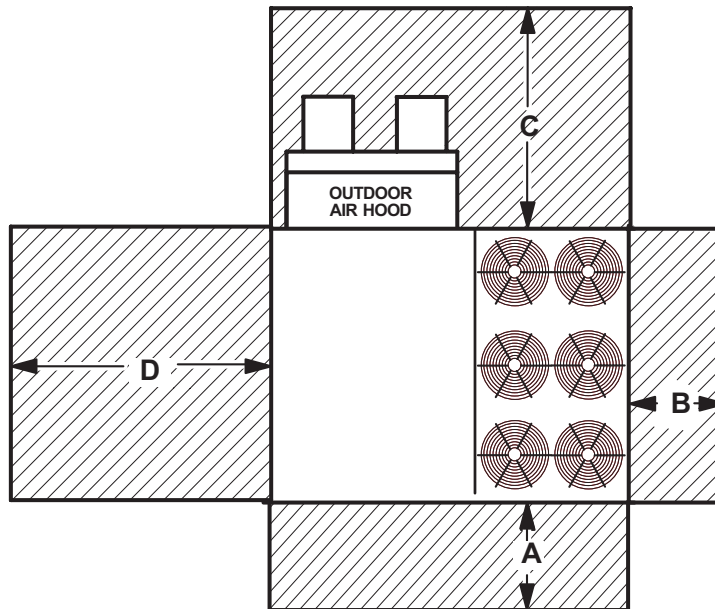

1 Unit Clearance	A		B		C		D		Top Clearance
	in.	mm	in.	mm	in.	mm	in.	mm	
Service Clearance	60	1524	36	914	80	2032	66	1676	Unobstructed
Clearance to Combustibles	36	914	1	25	1	25	1	25	
Minimum Operation Clearance	45	1143	36	914	80	2032	41	1041	

NOTE - Entire perimeter of unit base requires support when elevated above the mounting surface.

¹ Service Clearance - Required for removal of serviceable parts.

Clearance to Combustibles - Required clearance to combustible material.

Minimum Operation Clearance - Required clearance for proper unit operation.

UNIT CLEARANCES

Unit With Horizontal Barometric Relief Dampers

NOTE Allow adequate clearance for duct and barometric relief damper installation.

NOTE Dampers may be installed on each side of return air duct or end to end on one side of return air duct.

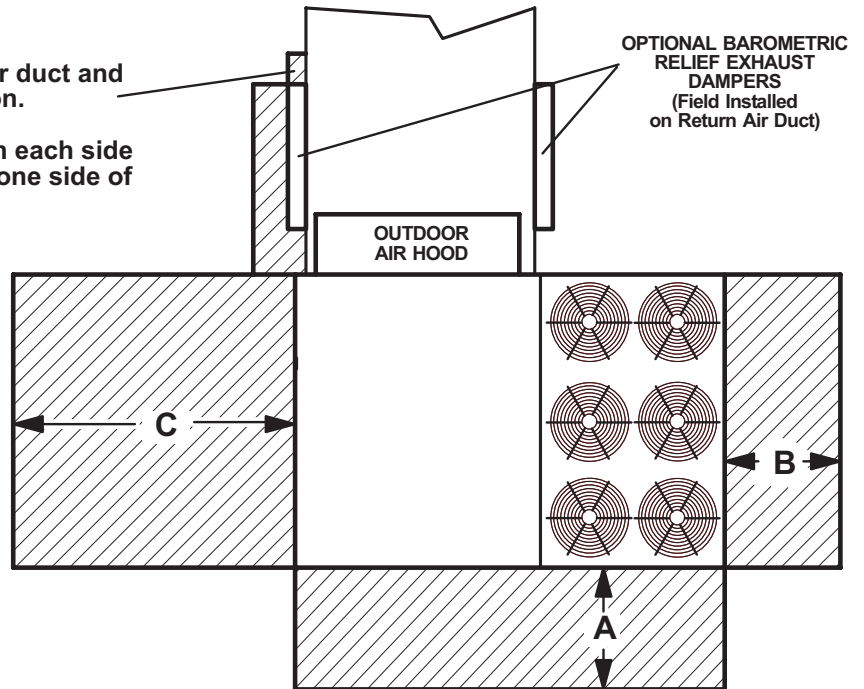

¹ Unit Clearance	A		B		C		Top Clearance
	in.	mm	in.	mm	in.	mm	
Service Clearance	60	1524	36	914	66	1676	Unobstructed
Clearance to Combustibles	36	914	1	25	1	25	
Minimum Operation Clearance	45	1143	36	914	41	1041	

NOTE - Entire perimeter of unit base requires support when elevated above the mounting surface.

¹ Service Clearance - Required for removal of serviceable parts.

Clearance to Combustibles - Required clearance to combustible material.

Minimum Operation Clearance - Required clearance for proper unit operation.

OUTDOOR SOUND DATA

Size	Octave Band Sound Power Levels dBA, re 10 ⁻¹² Watts - Center Frequency - Hz							¹ Sound Rating Number (dBA)
	125	250	500	1000	2000	4000	8000	
302, 360	84	85	90	90	85	80	72	95

Note - The octave sound power data does not include tonal corrections.

¹ Sound Rating Number according to ARI Standard 370-2001 (includes pure tone penalty).

The Sound Rating Number is the overall A-Weighted Sound Power Level, (LWA), dB (100 Hz to 10,000 Hz)

WEIGHT DATA

Size	Net		Shipping	
	lbs.	kg	lbs.	kg
302 Base Unit	3107	1435	3317	1505
302 Max. Unit	3585	1626	3795	1721
360 Base Unit	3107	1435	3317	1505
360 Max. Unit	3585	1626	3795	1721

FACTORY / FIELD INSTALLED OPTIONS AND ACCESSORIES - NET WEIGHTS

Description		lbs.	kg
ECONOMIZER / OUTDOOR AIR / EXHAUST			
Economizer		138	63
Barometric Relief			
Downflow Barometric Relief Dampers		45	20
Horizontal Barometric Relief Dampers		20	9
Outdoor Air Dampers			
Damper Section (downflow)	Motorized	72	33
Damper Section (downflow)	Manual	68	31
Outdoor Air Hood (downflow)		76	34
Power Exhaust			
Standard Static		99	45
High Static with or without VFD		525	238
GAS HEAT EXCHANGER (NET WEIGHT)			
Medium Heat (adder over standard heat)		18	8
High Heat (adder over standard heat)		64	29
COMBINATION COIL/HAIL GUARDS			
All models		63	29
ROOF CURBS			
Hybrid Roof Curbs, Downflow			
14 in. height		205	93
18 in. height		235	107
24 in. height		270	123
Standard Curbs, Horizontal			
30 in. height		495	225
41 in. height		575	261
Insulation Kit for Horizontal Curbs			
30 in. height		45	21
41 in. height		55	25
CEILING DIFFUSERS			
Step-Down	LARTD30/36S	625	283
Flush	LAFD30/36S	625	283
Transitions	LASRT30/36	85	39
HUMIDITROL® DEHUMIDIFICATION SYSTEM			
Humiditrol® Dehumidification Option		100	45

DIMENSIONS - UNIT

CORNER WEIGHTS

CENTER OF GRAVITY

Model No.	AA		BB		CC		DD		EE		FF	
	lbs.	kg	lbs.	kg	lbs.	kg	lbs.	kg	in.	mm	in.	mm
LGT302 Base Unit	632	287	635	288	912	414	928	421	60	1524	37	940
LGT302 Max. Unit	709	322	712	323	1023	464	1041	472	60	1524	37	940
LGT360 Base Unit	632	287	635	288	912	414	928	421	60	1524	37	940
LGT360 Max. Unit	709	322	712	323	1023	464	1041	472	60	1524	37	940

Base Unit - The unit with NO INTERNAL OPTIONS.

Max. Unit - The unit with ALL INTERNAL OPTIONS Installed. (Economizer, Standard Static Power Exhaust, Controls, etc.). Does not include accessories external to unit or high static power exhaust.

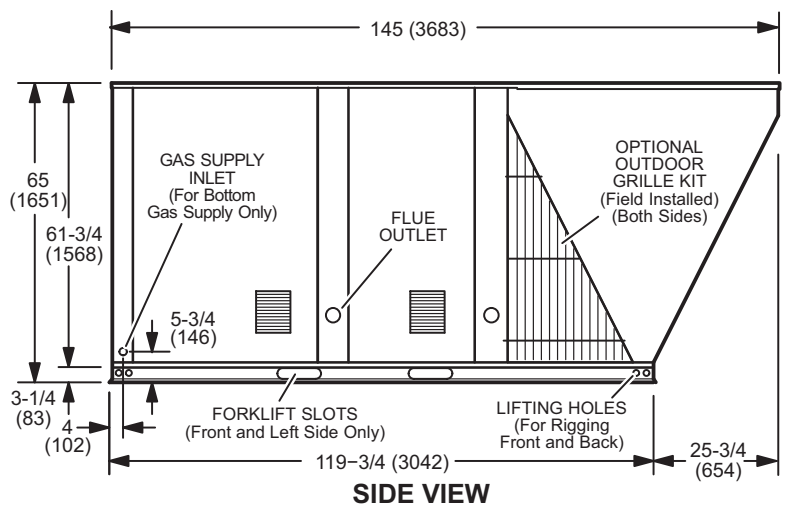
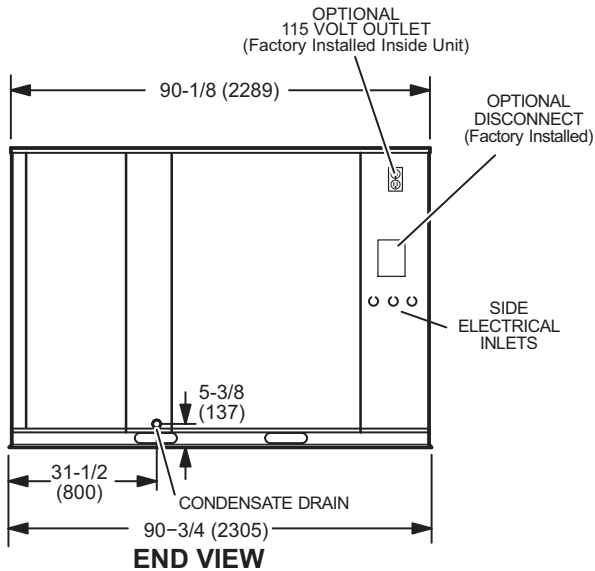
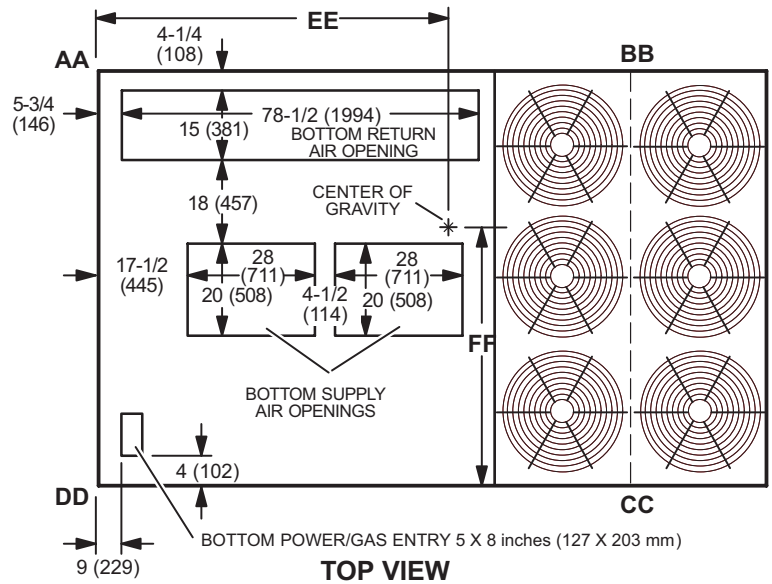

OUTDOOR AIR HOOD DETAIL

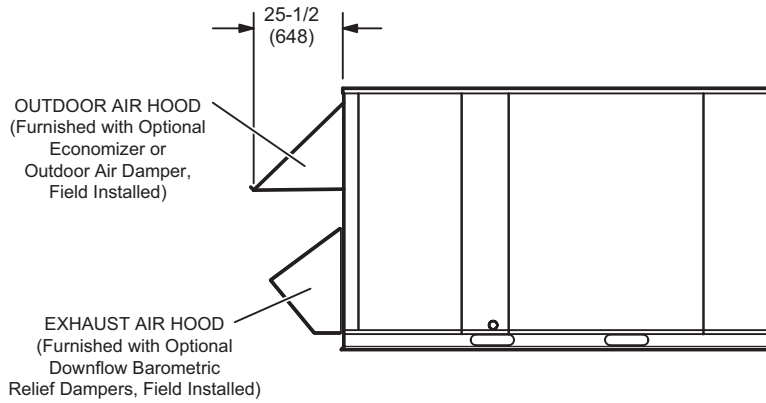

OPTIONAL HIGH STATIC POWER EXHAUST FANS DETAIL

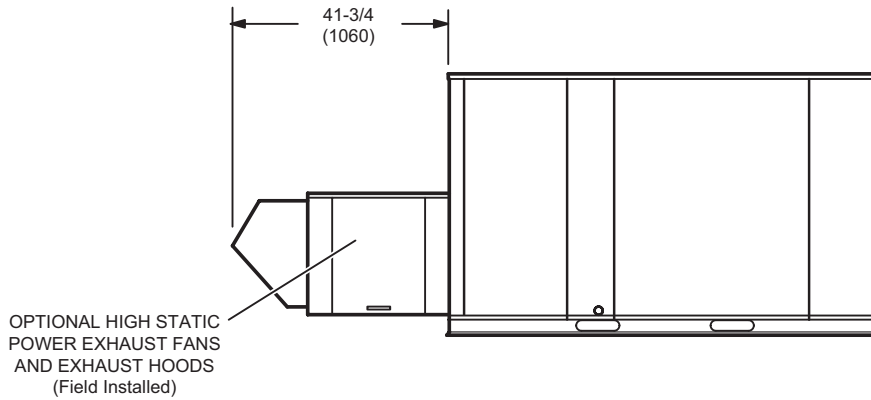

OPTIONAL HORIZONTAL BAROMETRIC RELIEF DAMPERS WITH HOOD

(Field installed in horizontal return air duct adjacent to unit)

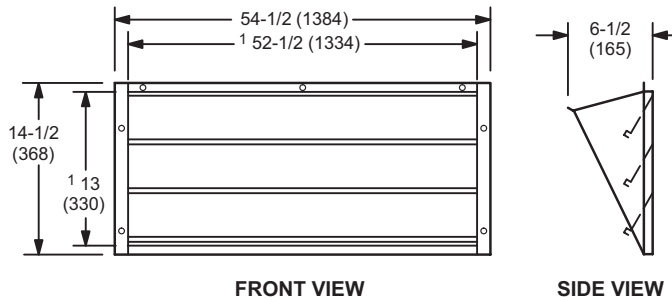

NOTE - Two furnished per order no.

¹ NOTE - Opening size required in return air duct.

ROOF CURBS WITH SUPPLY & RETURN AIR TRANSITIONS FOR CEILING DIFFUSERS

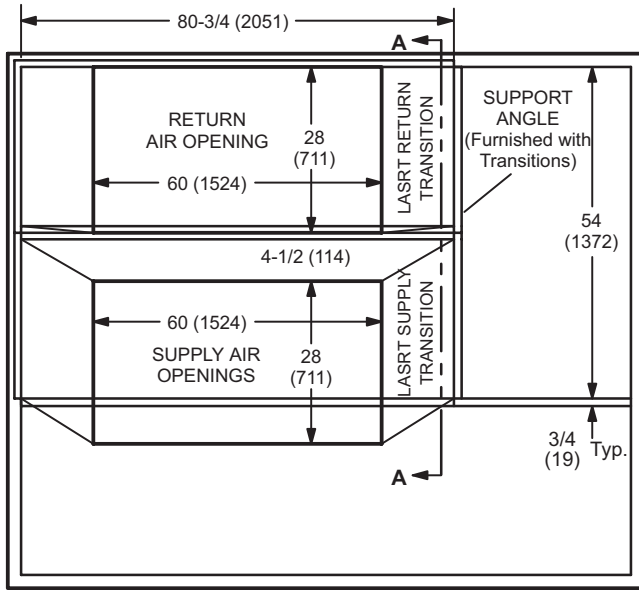

TOP VIEW

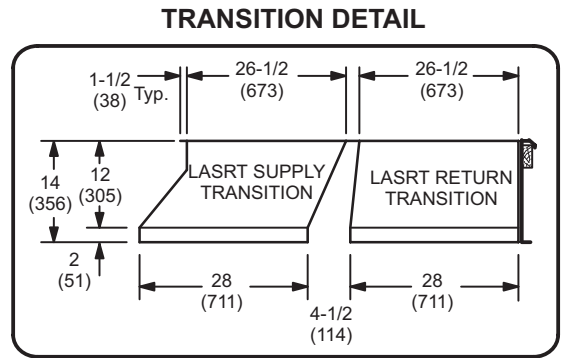

SECTION B-B

DIMENSIONS - ACCESSORIES

HORIZONTAL ROOF CURBS – Requires Optional Horizontal Return Air Panel Kit

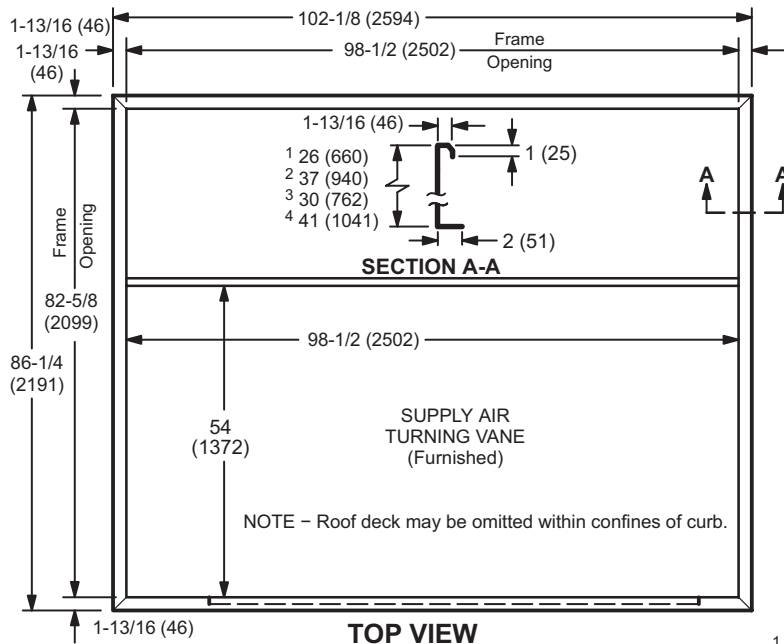

NOTE - 30 in. (762 mm) height Curb is designed for horizontal discharge when unit is mounted on a slab.
 41 in. (1041 mm) height Curb is designed for horizontal discharge when unit is mounted on a rooftop.

PANEL TO COVER RETURN AIR OPENING IN BOTTOM OF UNIT (Furnished With Optional Horizontal Return Air Panel Kit)

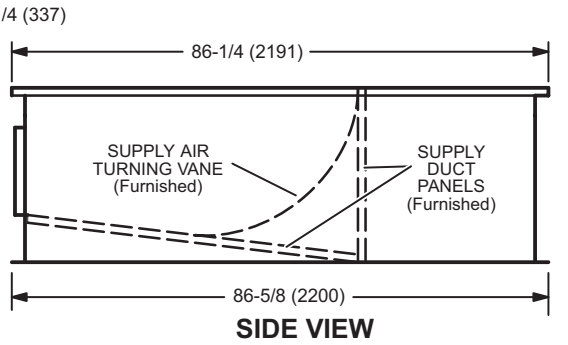
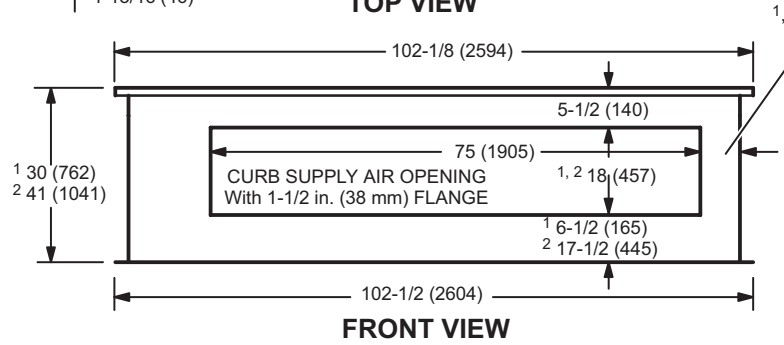
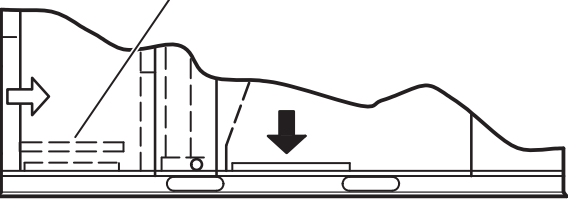

1 Slab Applications 2 Rooftop Applications

HORIZONTAL SUPPLY AND RETURN AIR OPENINGS ROOFTOP UNIT WITH HORIZONTAL ROOF CURB

1 Slab Applications 2 Rooftop Applications

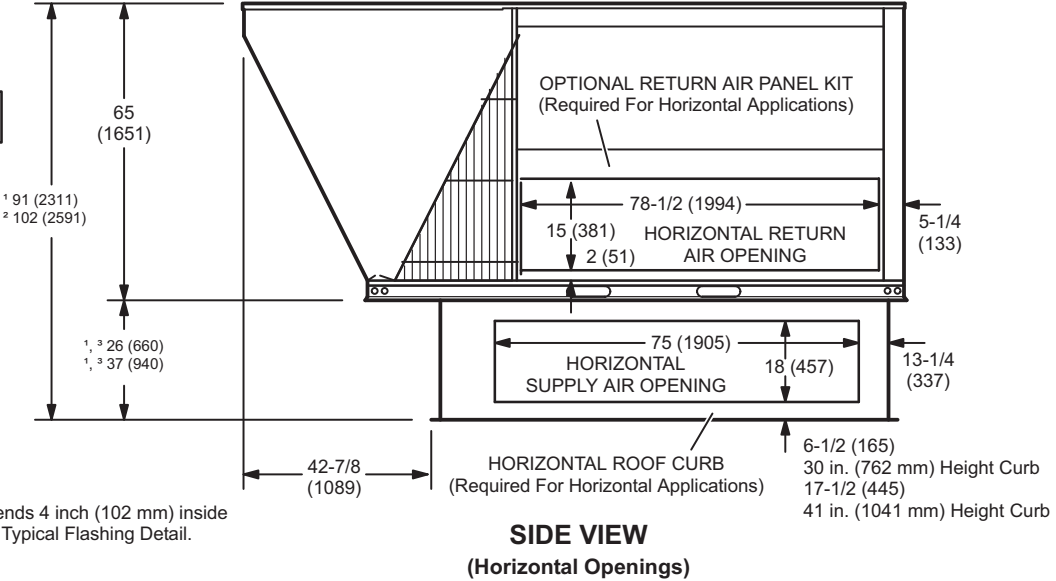

3 NOTE – Top of Curb extends 4 inch (102 mm) inside bottom of unit base. See Typical Flashing Detail.

DIMENSIONS - ACCESSORIES

COMBINATION CEILING SUPPLY AND RETURN DIFFUSERS

STEP-DOWN CEILING DIFFUSER

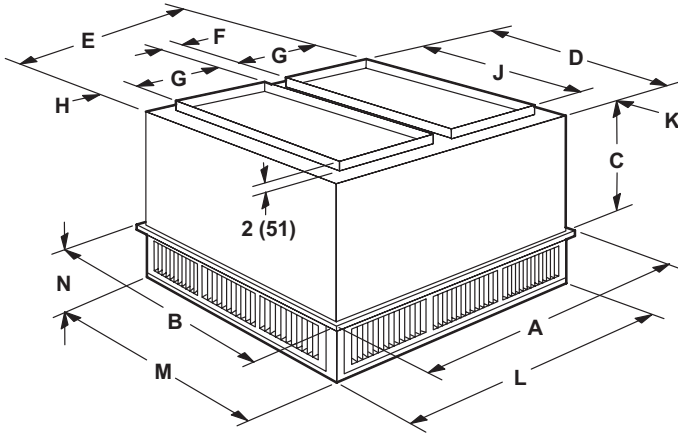

FLUSH CEILING DIFFUSER

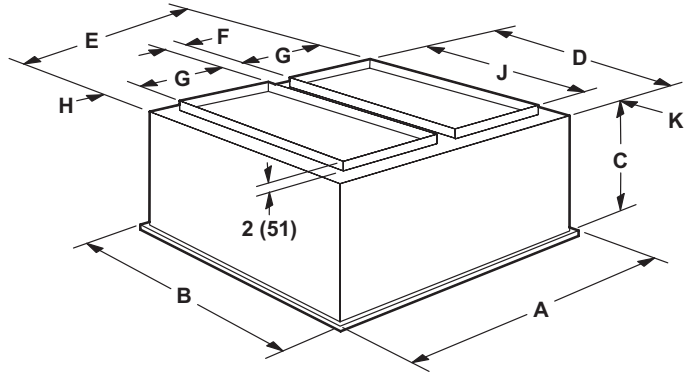

Model		LARTD30/36S
A	in.	65-5/8
	mm	1667
B	in.	65-5/8
	mm	1667
C	in.	40-1/2
	mm	1029
D	in.	63-1/2
	mm	1613
E	in.	63-1/2
	mm	1613
F	in.	4-1/2
	mm	114
G	in.	28
	mm	711
H	in.	1-1/2
	mm	38
J	in.	60
	mm	1524
K	in.	1-3/4
	mm	44
L	in.	63-1/2
	mm	1613
M	in.	63-1/2
	mm	1613
N	in.	12-1/8
	mm	308
Duct Size	in.	28 x 60
	mm	711 x 1524

Model		LAFD30/36S
A	in.	65-5/8
	mm	1667
B	in.	65-5/8
	mm	1667
C	in.	40
	mm	1016
D	in.	63-1/2
	mm	1613
E	in.	63-1/2
	mm	1613
F	in.	4-1/4
	mm	108
G	in.	28
	mm	711
H	in.	1-5/8
	mm	32
J	in.	60
	mm	1524
K	in.	1-3/4
	mm	44
Duct Size	in.	28 x 60
	mm	711 x 1524



Visit us at www.Lennox.com

For the latest technical information, www.LennoxCommercial.com

Contact us at 1-800-4-LENNOX

NOTE - Due to Lennox' ongoing commitment to quality, Specifications, Ratings and Dimensions subject to change without notice and without incurring liability. Improper installation, adjustment, alteration, service or maintenance can cause property damage or personal injury. Installation and service must be performed by a qualified installer and servicing agency.

©2024 Lennox Industries, Inc.