

PACKAGED UNITS KITS AND ACCESSORIES

506410-05
6/2024
Supersedes 3/2023

COLD WEATHER KIT

INSTALLATION INSTRUCTIONS FOR COLD WEATHER KIT USED ON LG/LD/KG/KD 092-300 GAS PACKAGED UNITS

⚠️WARNING

Improper installation, adjustment, alteration, service or maintenance can cause property damage, personal injury or loss of life. Installation and service must be performed by a licensed professional HVAC installer or equivalent, service agency, or the gas supplier.

Shipping and Packing List

13X63, 13X64, 13X65, 22A51, 22A55

Package 1 of 1 contains:

- 1- Heater assembly
- 4- Wire harnesses (2 in 13X63 & 13X64)

Bag assembly containing:

- 1-Relay
- 9-#8 Screws
- 1-Wire tie

22H58, 22H59, 22V43

Package 1 of 1 contains:

- 2- Heater assemblies
- 7- Wire harnesses
 - 1- 106051-01 (LGH units)
 - 1- 604785-01 (KG Units- std. SCCR)
 - 2- 106128-01 HR6 power harnesses (KG)
 - 1- 105722-01 (LGH units - higher SCCR)
 - 1- 106648-01 (LGM units)
 - 1- 107210-01 (LGT/LDT units)

Bag assembly containing:

- 2- Relays
- 18- Thread forming screws
- 24- Wire ties

⚠️WARNING

To prevent serious injury or death:

1. Lock-out/tag-out before performing maintenance.
2. If system power is required (e.g., smoke detector maintenance), disable power to blower, remove fan belt where applicable, and ensure all controllers and thermostats are set to the "OFF" position before performing maintenance.
3. Always keep hands, hair, clothing, jewelry, tools, etc., away from moving parts.

Application

The cold weather kit heats the gas heat compartment to allow gas valve operation during low outdoor temperatures. See table 1 for usage.

TABLE 1

Unit	Unit Voltage	Part No.	Cat. No.
LGH/KG 092-152	Y	613930-01	13X63
LGH/KG 092-152	G, M	613930-02	13X64
LGM/LGT/LD/KG/KD 078-152	J	613930-03	13X65
LGM/LGT/LD/KD 078-152	Y	613930-07	22A51
LGM/LGT/LD/KD 078-152	G, M	613930-08	22A55
LG/LD/KG 156-300(S)	Y	613930-10	22H58
LG/LD/KG 156-300(S)	G, M	613930-11	22H59
LG/LD/KG 156-300(S)	J	613930-12	22V43

Installation - LGH092-150 Units

- 1 - Disconnect all power to unit and open heat access panel.
- 2 - Locate the kit harness labeled 604954-01 kit harness. Remove cold weather kit cover and connect wires labeled HR6 to the cold weather assembly. See figure 1. Replace cold weather kit cover. Discard harness labeled 604956-01 provided in kit
- 3 - Install heater assembly in heat section as shown in figure 2. Use existing screws.
- 4 - Route the remaining harness wires as shown in figure 2. Make wire connections as shown in figure 1.
- 5 - Open control access panel and install K125 as shown in figure 3. Secure with #8 screws provided in kit.
- 6 - Locate existing wires in control box and connect to K125 as shown in figure 3 for standard SCCR units and figure 4 for high SCCR units.

⚠️CAUTION

As with any mechanical equipment, contact with sharp sheet metal edges can result in personal injury. Take care while handling this equipment and wear gloves and protective clothing.



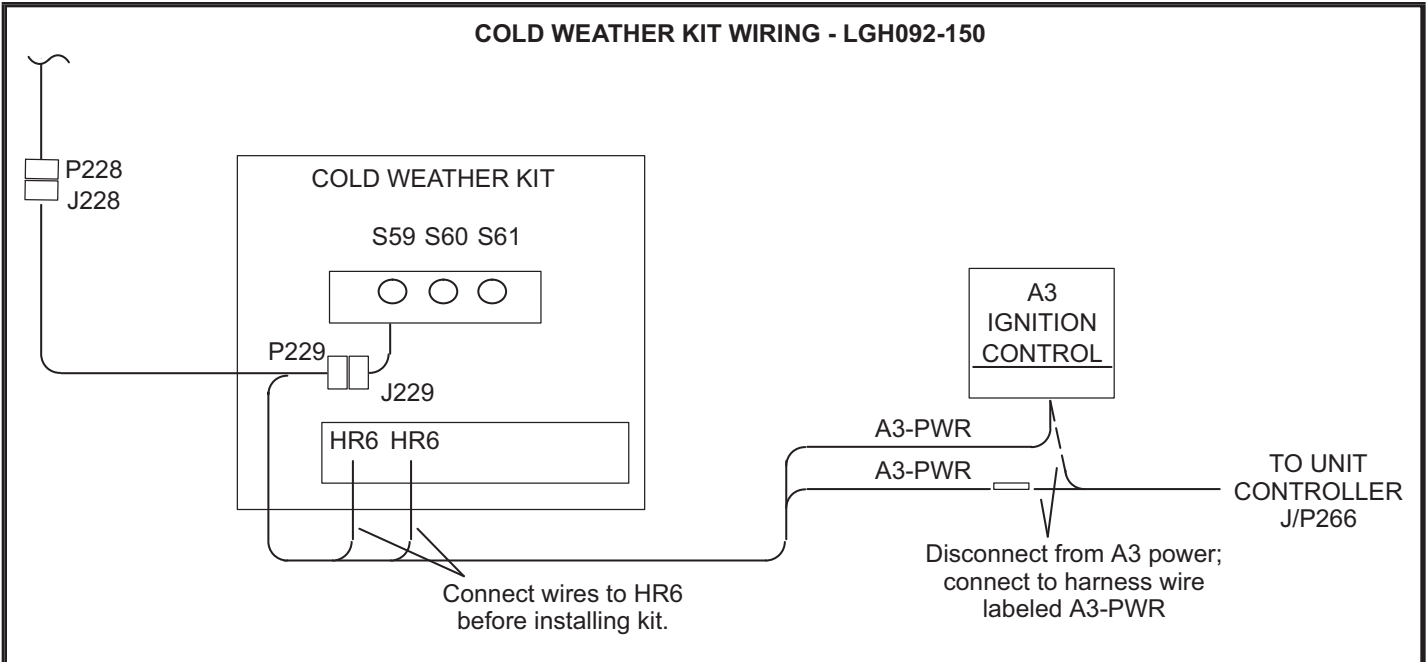

FIGURE 1

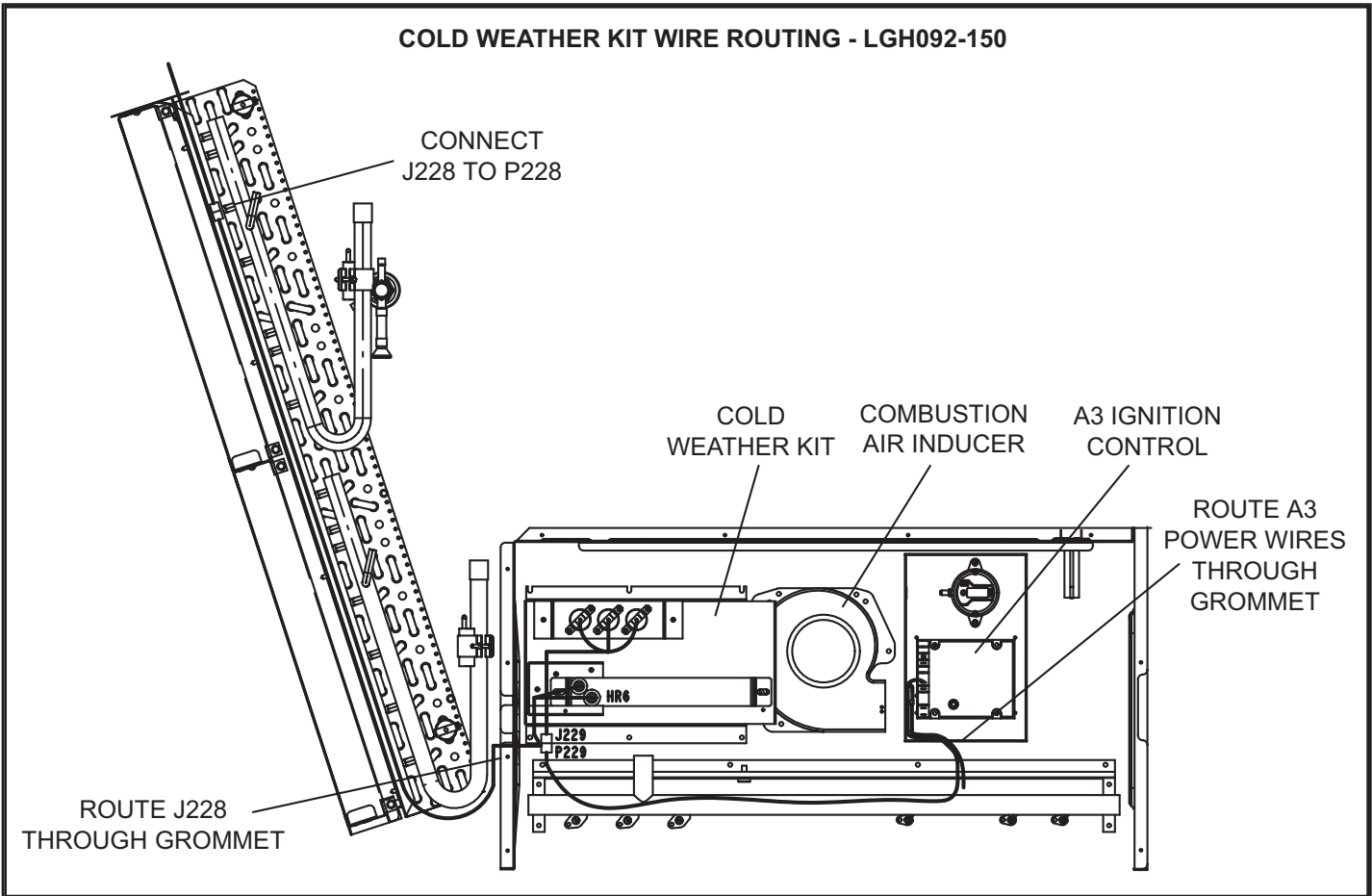
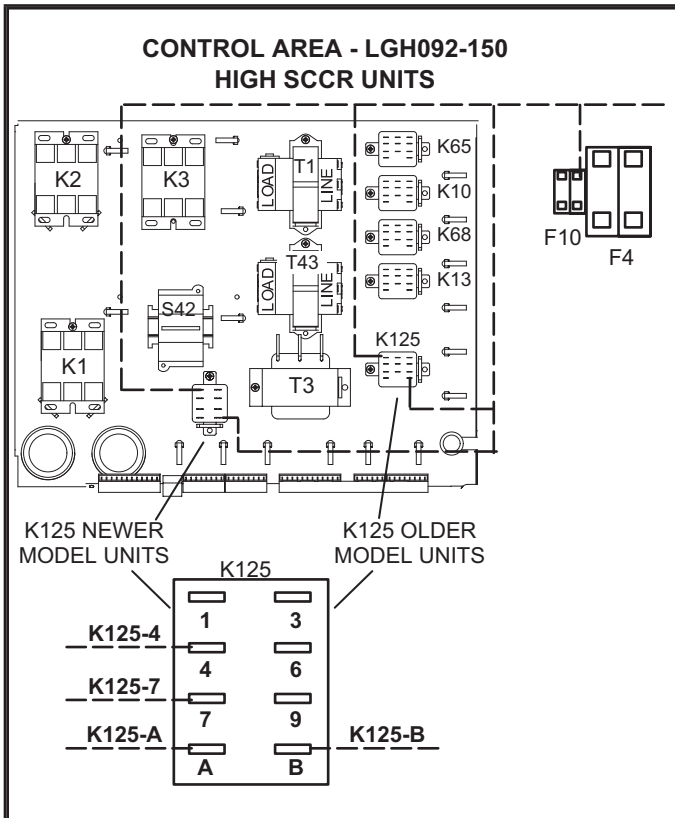
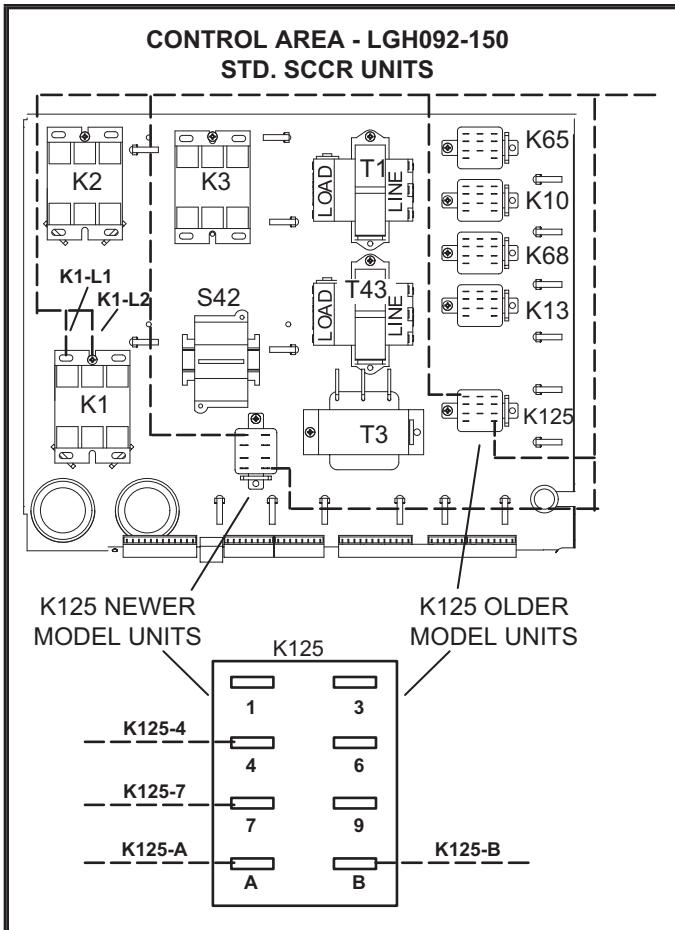
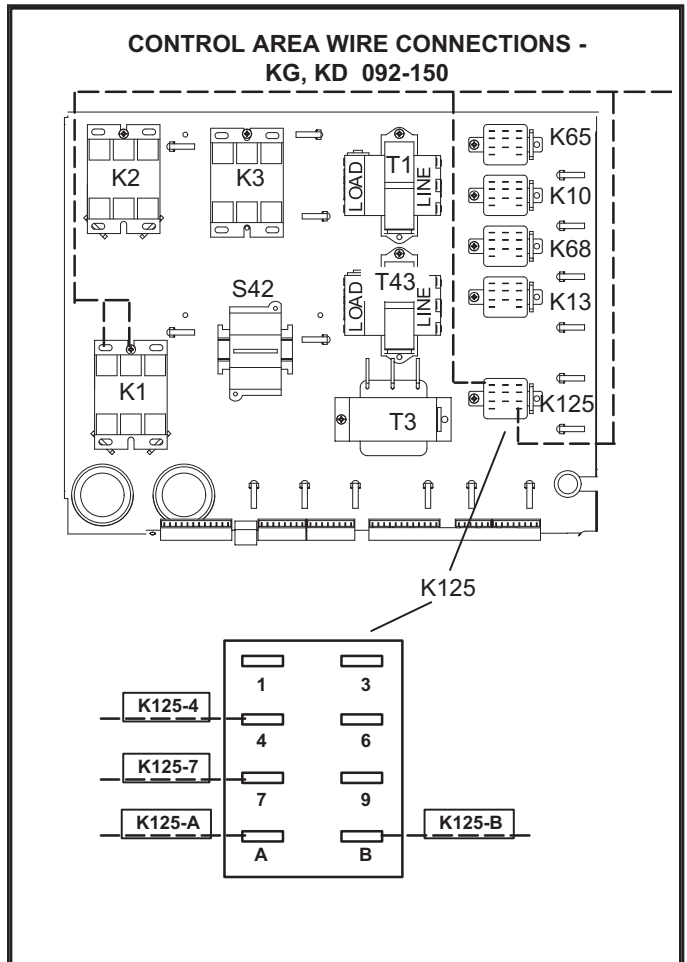

FIGURE 2



Installation - KG, KD 092-150 Units

- 1 - Disconnect all power to unit and open heat access panel.
- 2 - Remove six screws that are holding the unit top to the compressor area corner mullion.
- 3 - Locate the kit harness labeled 604956-01 and identify six wires labeled K1-L1, K1-L2, K125-4, K125-7, K125-A, and K125-B. Route the six wires from the heat section through the side grommet to the control box. See figure 6. Discard harness labeled 604954-01 provided in kit
- 4 - Remove cold weather kit cover and connect wires labeled HR6 to the cold weather assembly. See figure 7. Replace cold weather kit cover.
- 5 - Install heater assembly in heat section as shown in figure 2. Use existing screws.
- 6 - Open control access panel and install K125 as shown in figure 3. Secure with #8 screws provided in kit.
- 7 - Make wire connections in the control box as shown in figure 5 and in the heat section as shown in figure 7.
- 8 - Replace top panel and secure in place.



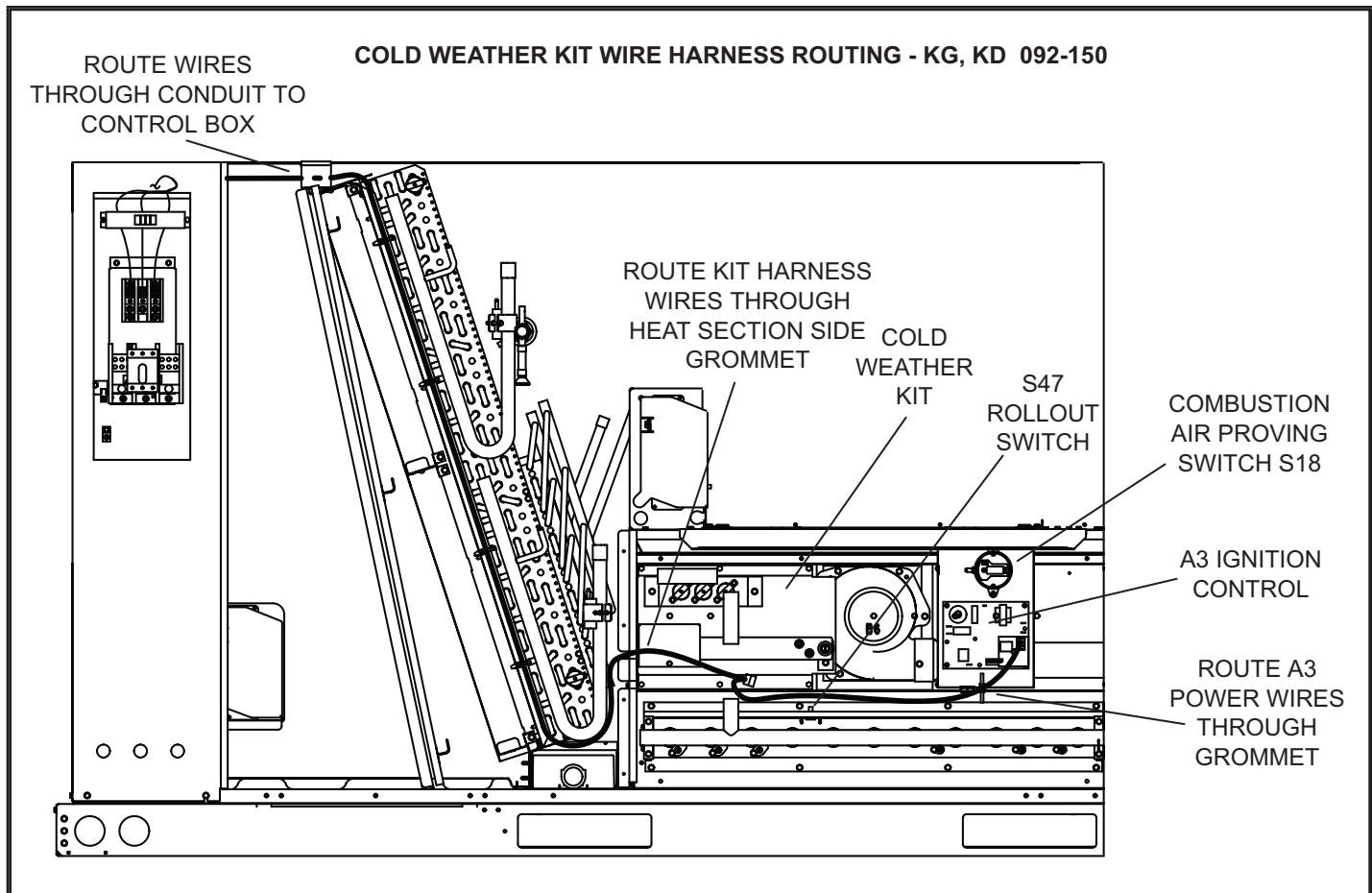

FIGURE 6

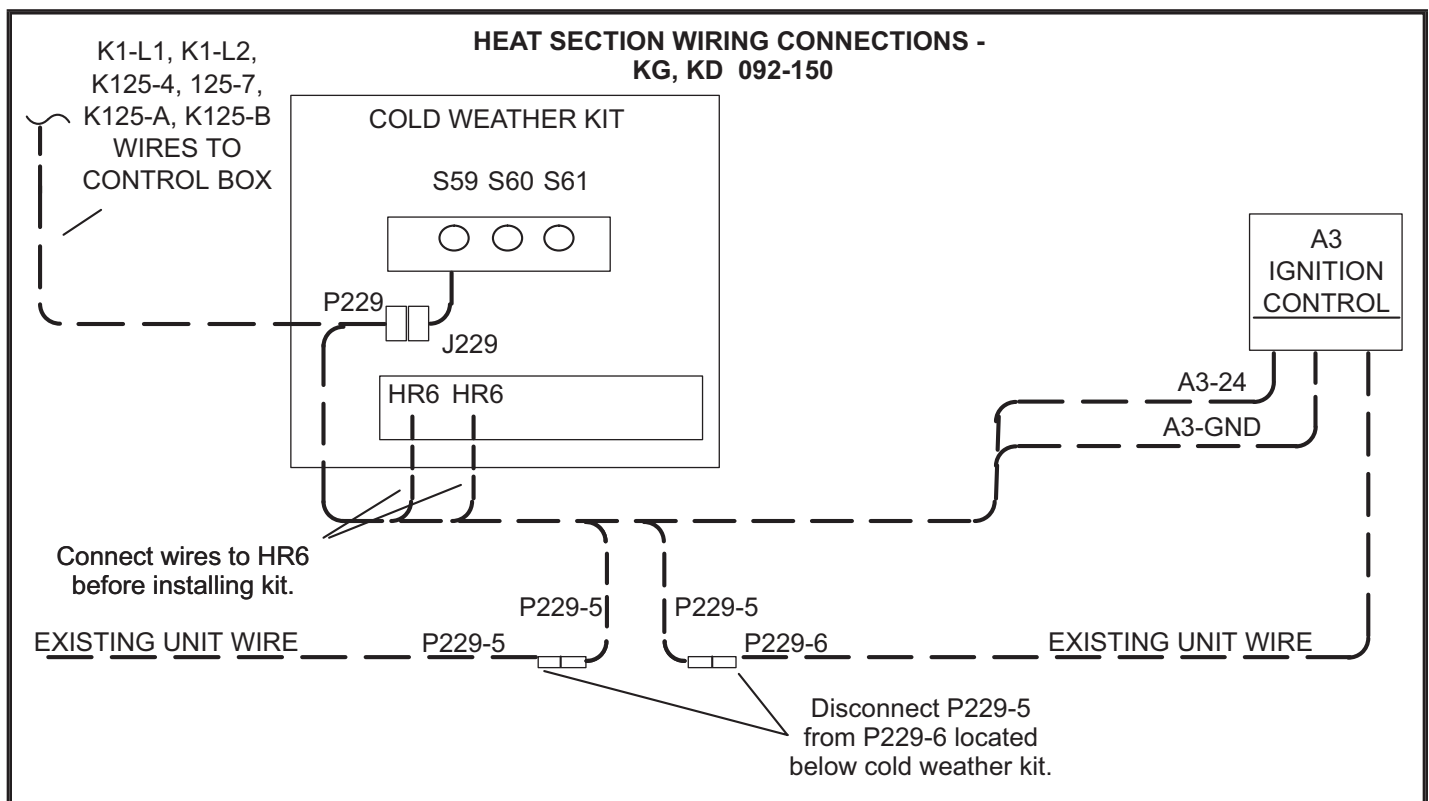

FIGURE 7

Installation - LGM, LGT, LD 092-150

- 1 - Disconnect all power to unit and open heat access panel. See figure 8.
- 2 - Discard harnesses labeled 604954-01 and 604956-01. Locate the kit power harness which has two 2-pin connectors labeled J/P228.
- 3 - Remove strip heater junction box cover. Route two power harness wires labeled HR6 through the junction box side grommet and connect to the strip heater terminals. See figure 9. Replace junction box cover.
- 4 - Install heater assembly in heat section as shown in figure 10. Use existing screws.
- 5 - Remove ignition control cover and install K125 as shown in figure 10. Secure with #8 screws provided in kit.
- 6 - Disconnect unit J/P425 connectors. See figure 10. Connect power harness J/P228 to J/P425. See figure 11.
- 7 - Route remaining power harness wires labeled K125-4, -6, -7, -9 through the grommets in the bottom of the ignition control box. Connect to appropriate terminals.

- 8 - Locate kit control harness that has a 6-pin, 4-wire connector labeled P229. Connect P229 to J229 cold weather kit harness. See figure 12.
- 9 - Route the other end of the P229 harness to the heat section and make wire connections. See figure 13.

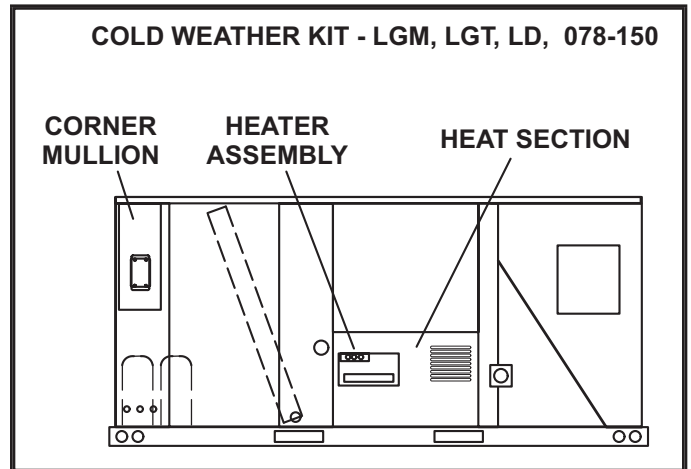

FIGURE 8

CONNECT STRIP HEATER WIRES - LGM, LGT, LD 078-150

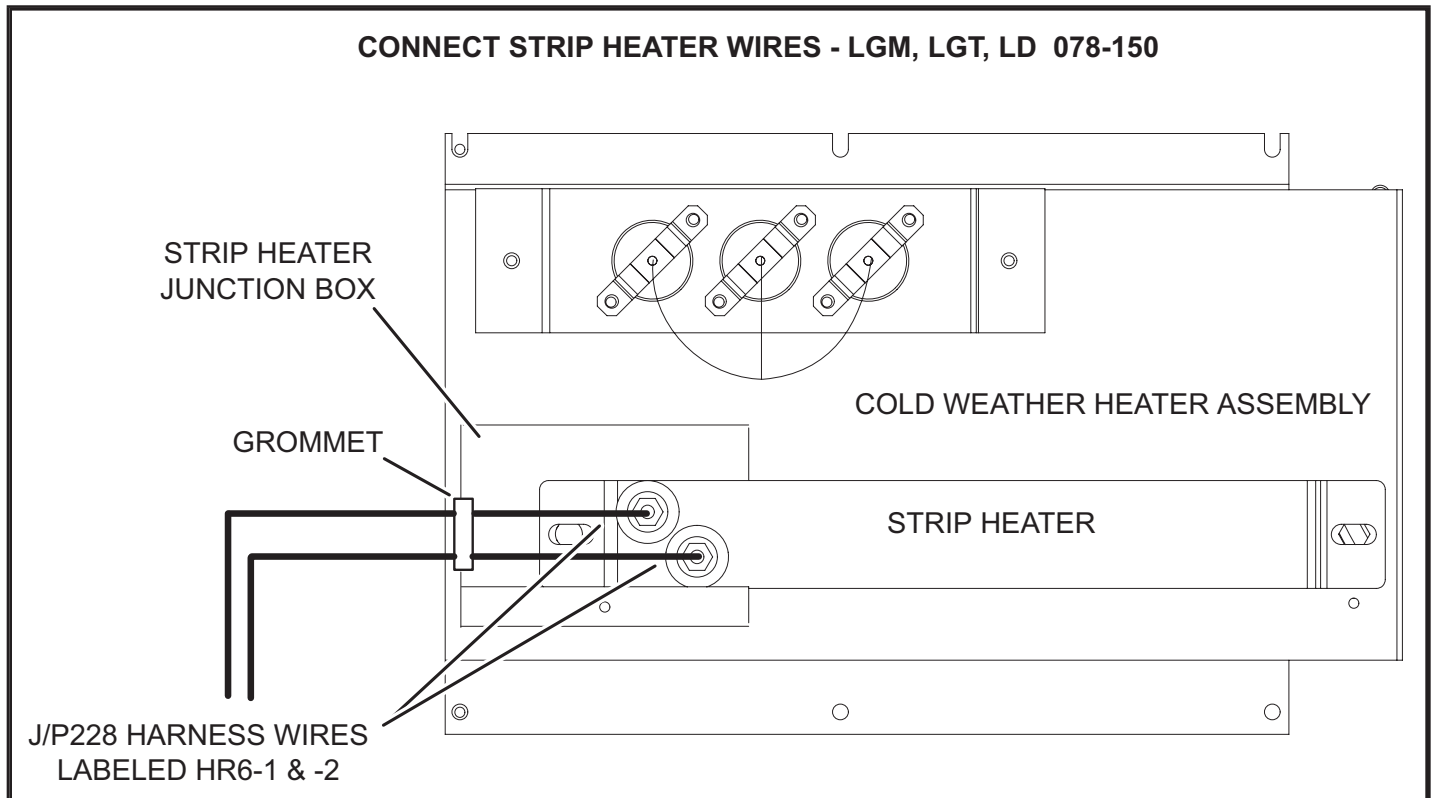

FIGURE 9

INSTALL HEATER ASSEMBLY - LGM, LGT, LD 078-150

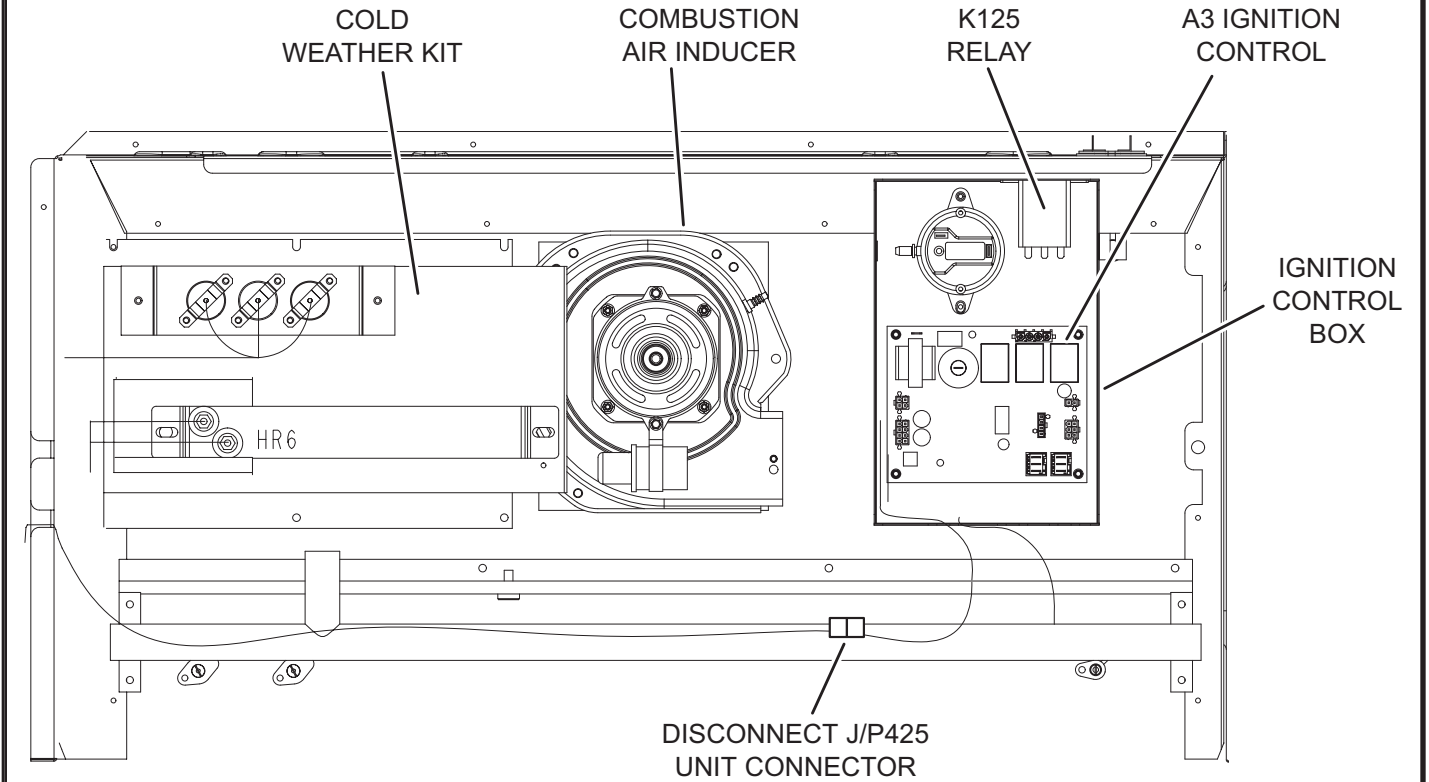

FIGURE 10

J/P228 POWER HARNESS - LGM, LGT, LD 078-150 K125

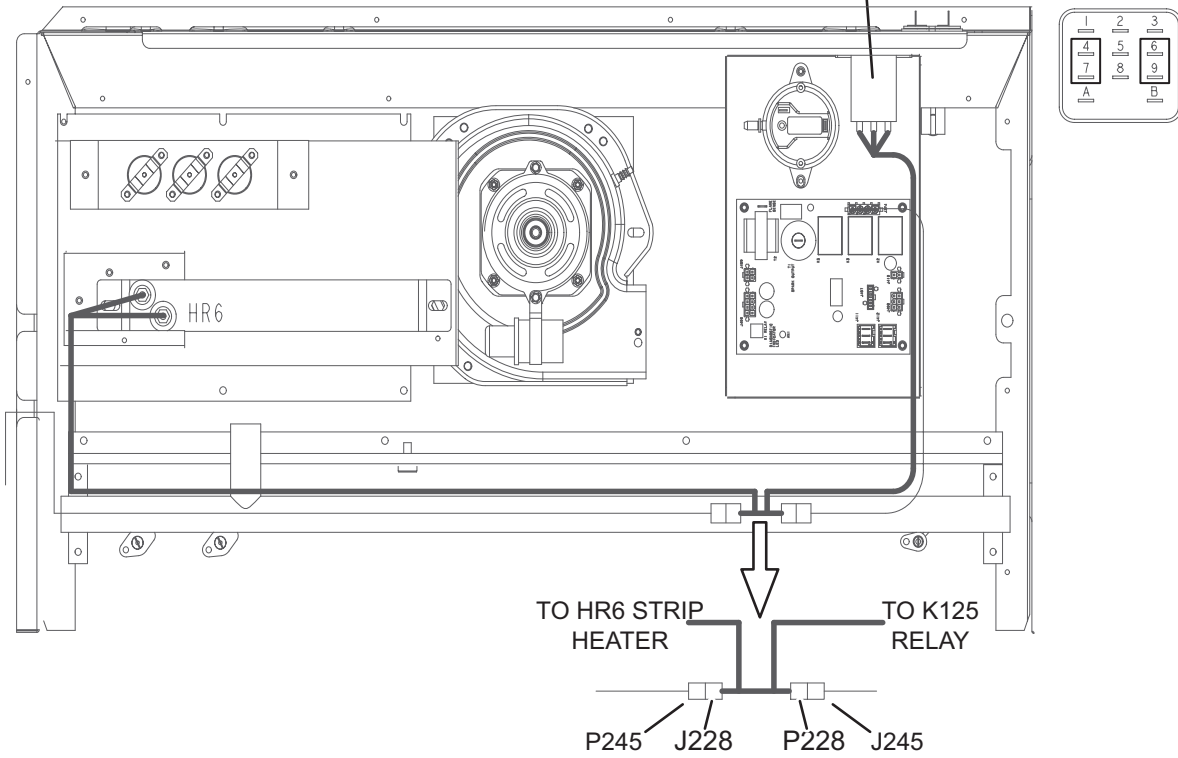
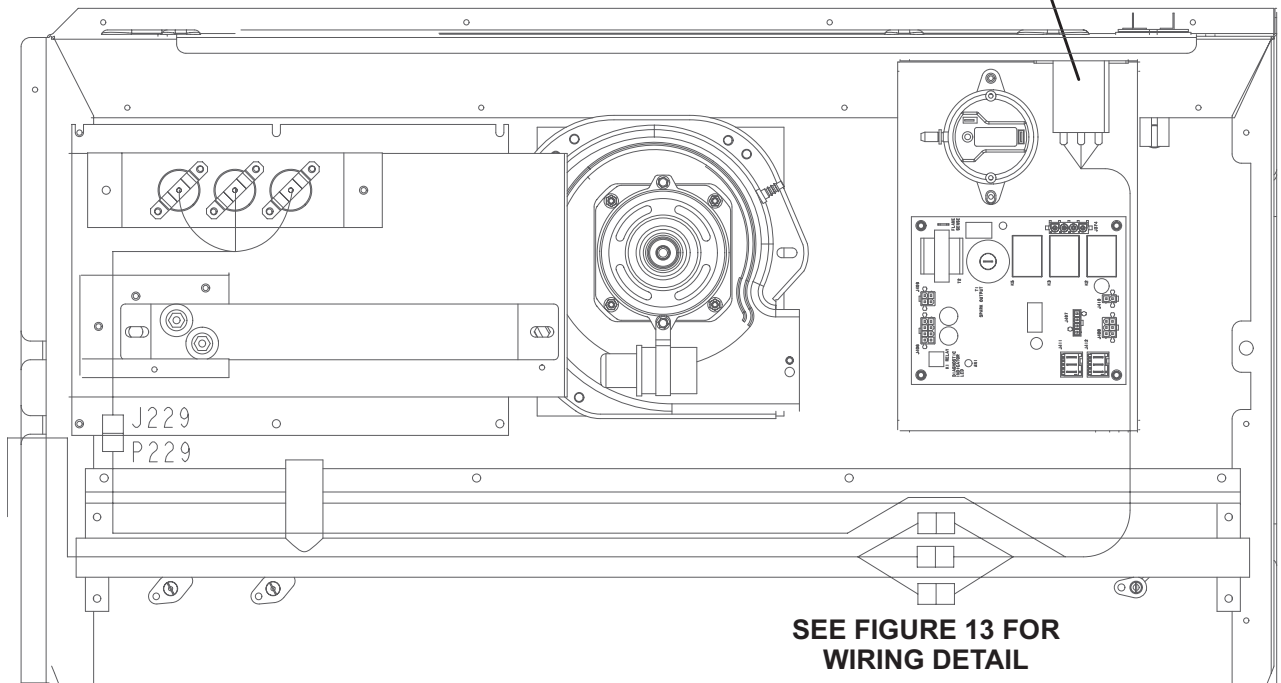

FIGURE 11

J/P229 CONTROL HARNESS - LGM, LGT, LD 078-150 K125



**SEE FIGURE 13 FOR
WIRING DETAIL**

FIGURE 12

J/P229 CONTROL HARNESS CONNECTIONS - LGM, LGT, LD 078-150

TO K125
RELAY COIL

CONTROL
HARNESS P229

K125-A (10)
K125-B (11)

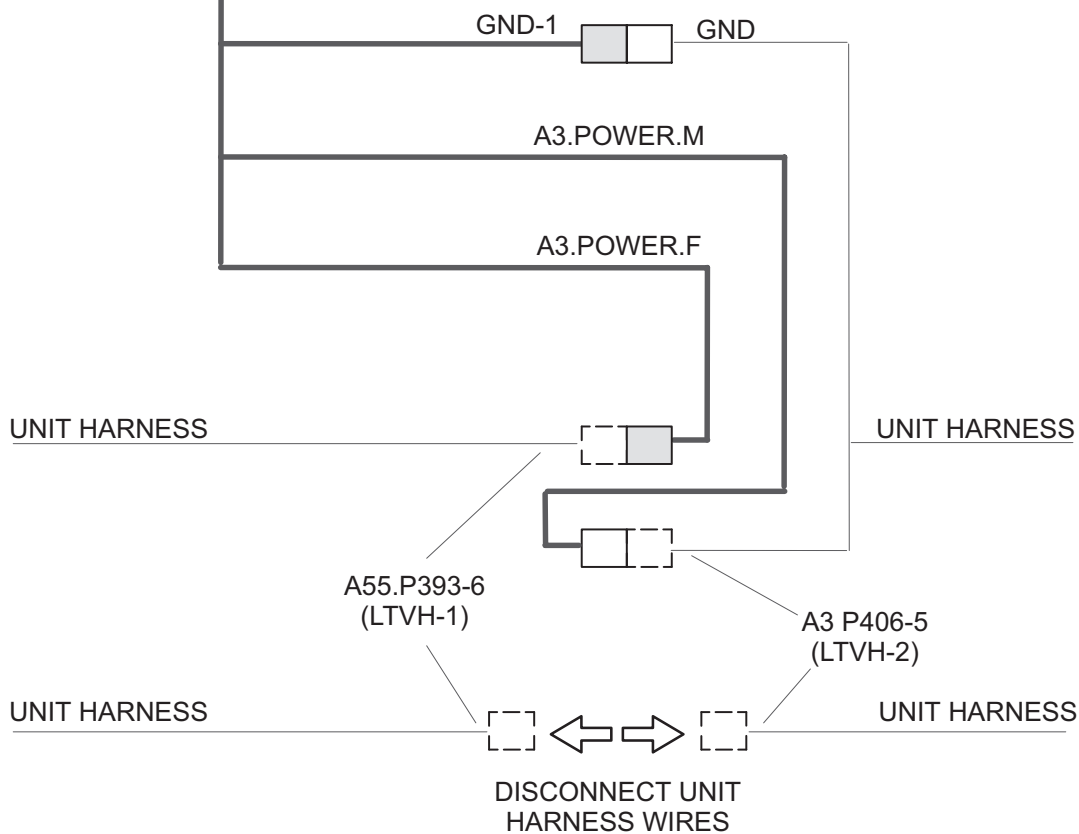

FIGURE 13

Installation - LGH156-300 Units

- 1 - Disconnect all power to unit and open heat access panel.
- 2 - Install both cold weather assemblies as shown in figure 14. Use existing screws.
- 3 - Install both K125 relays in control area above compressors. Secure with #8 screws. See figure 15.
- 4 - Locate harness labeled 106051-01 for standard SCCR units or 105722-01 for high SCCR units. Route as shown in figure 15. Secure with wire ties. Discard unused harnesses.
- 5 - Make wire connections as shown in figure 16.
- 6 - Use wire ties to securely route and tie harness away from gas heat manifold.

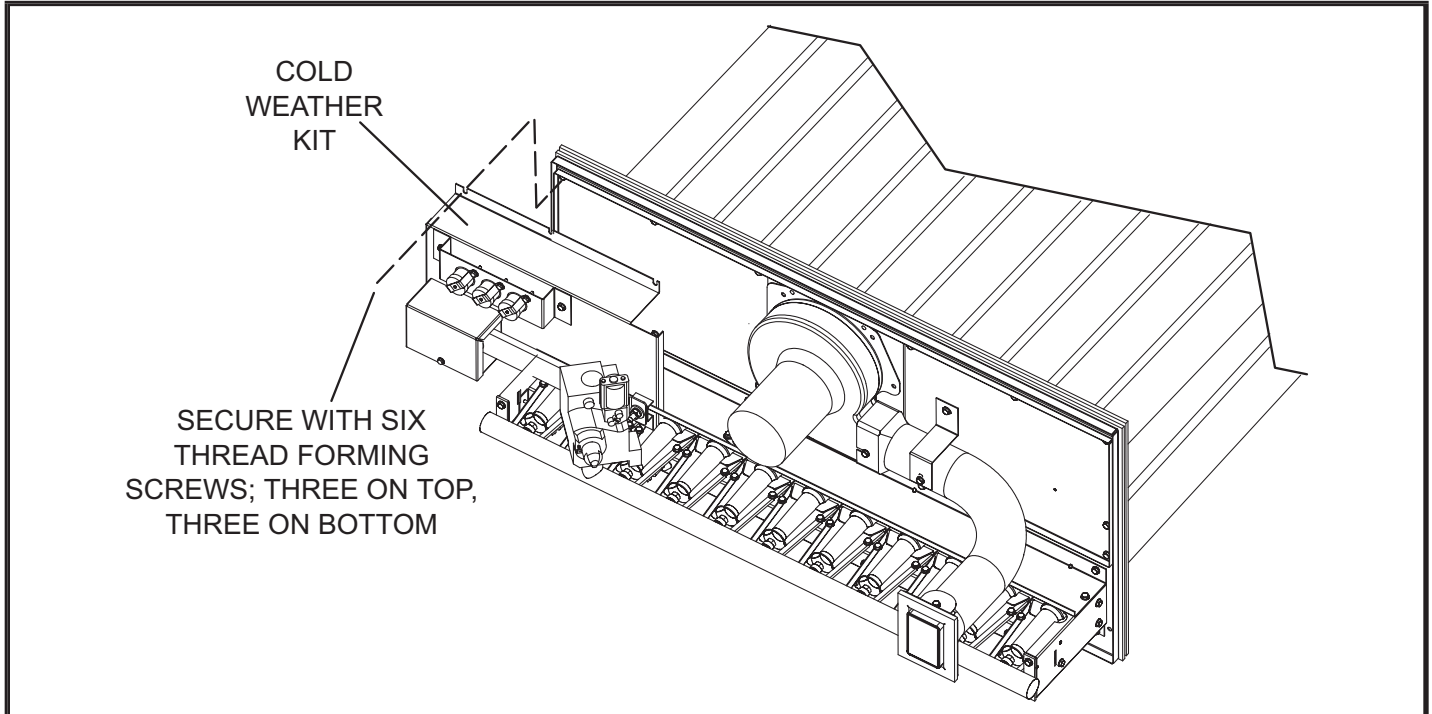

FIGURE 14

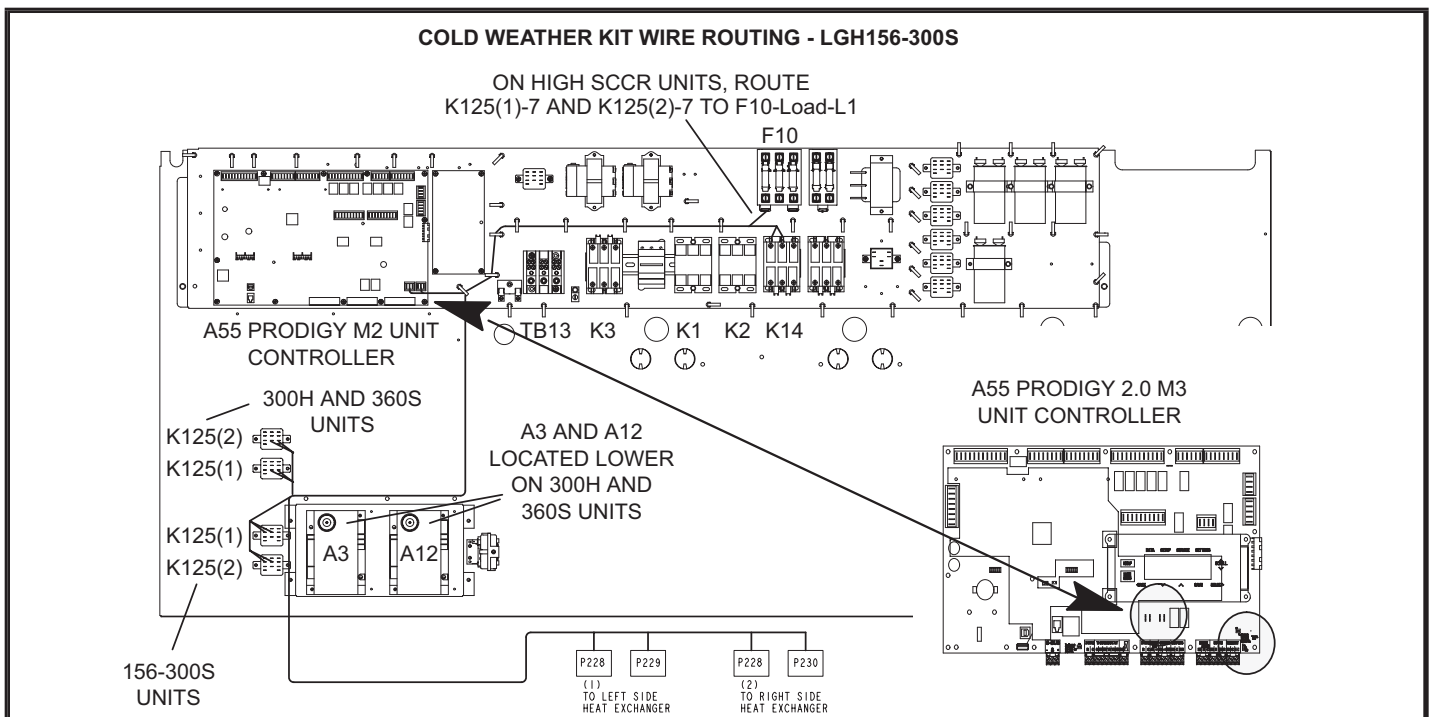

FIGURE 15

COLD WEATHER KIT WIRING - LGH156-360

A55 - PRODIGY 2.0
M3 UNIT CONTROLLER

DISCONNECT WIRES
FROM IGNITION BOARD
A3 AND A12

--- KIT HARNESS

PWR

A3/A12

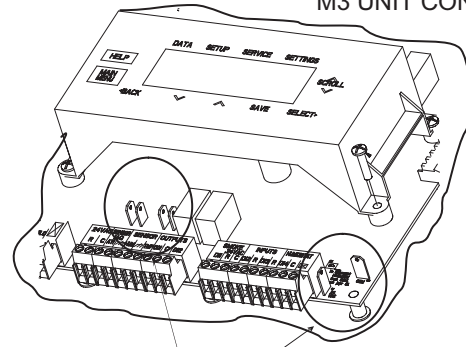

CONNECT TO A55
UNIT CONTROLLER

24VAC
24VAC-COM

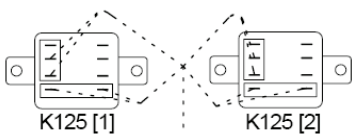

K125 [1]

K125 [2]

CONNECT PREVIOUSLY
DISCONNECTED UNIT
WIRING TO KIT HARNESS

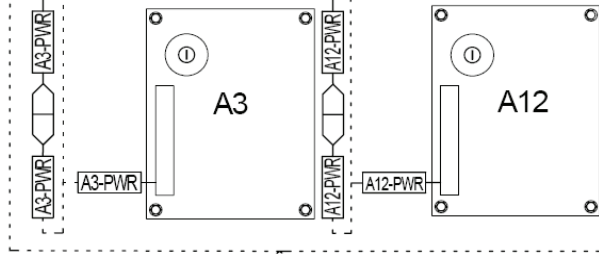

A3

A12

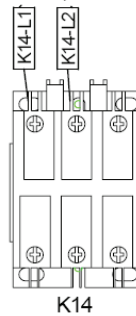

K14-L1

K14-L2

K14

A55 - PRODIGY
M2 UNIT CONTROLLER

J228 P228 [1]

J229 P229

VESTIBULE
HEATER
ASSEMBLY
LEFT SIDE

J228 P228 [2]

J230 P230

VESTIBULE
HEATER
ASSEMBLY
RIGHT SIDE

FIGURE 16

Installation - KG, KD 156-300 Units

- 1 - Disconnect all power to unit and open compressor access panels.
- 2 - Install both cold weather assemblies as shown in figure 14. Use existing screws.
- 3 - Install both K125 relays in control area above compressors. Secure with #8 screws. See figure 17.

- 4 - Locate harness labeled 604785-01 and route as shown in figure 15. Secure with wire ties. Discard unused harnesses.
- 5 - Make wire connections as shown in figure 18.
- 6 - Use wire ties to securely route and tie harness away from gas heat manifold.

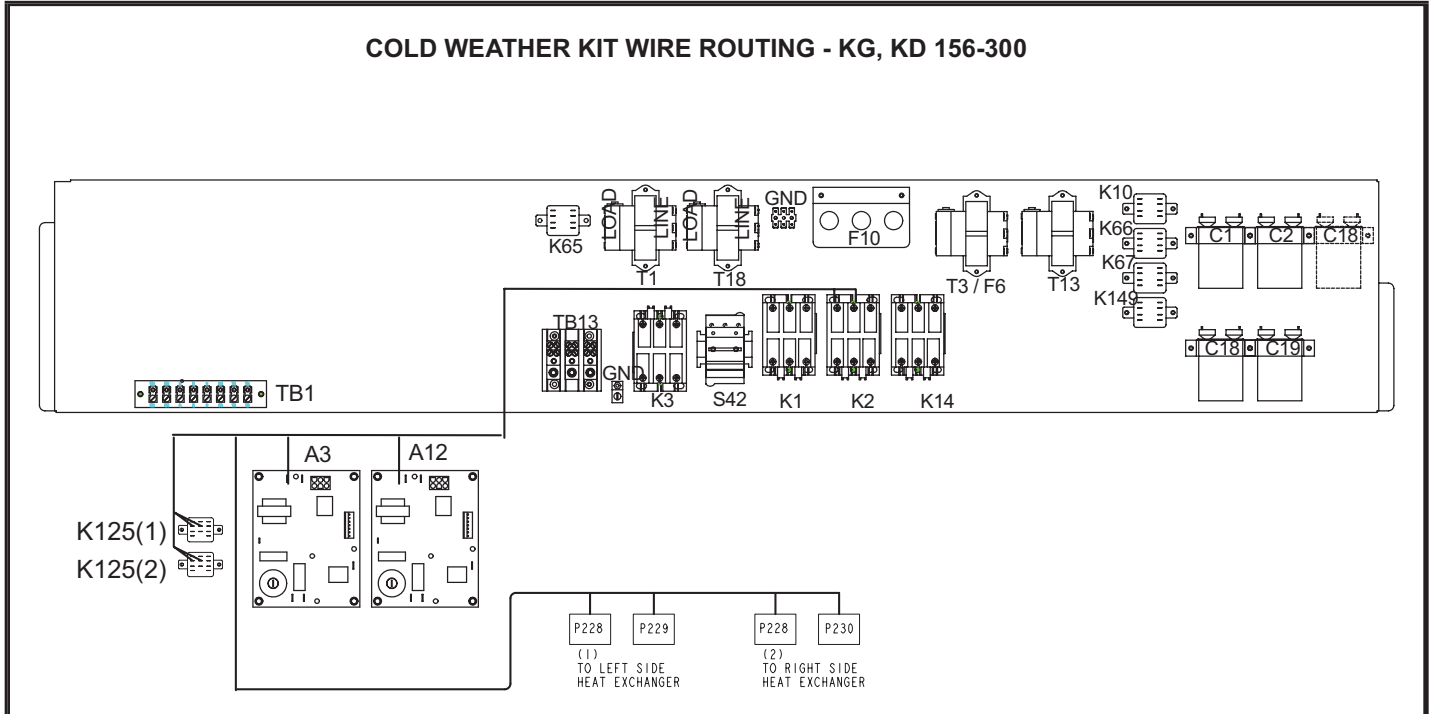

FIGURE 17

COLD WEATHER KIT WIRING - KG, KD 156-300

DISCONNECT WIRES FROM IGNITION BOARD A3 AND A12

DISCONNECT WIRES FROM K2 CONTACTOR

----- KIT HARNESS

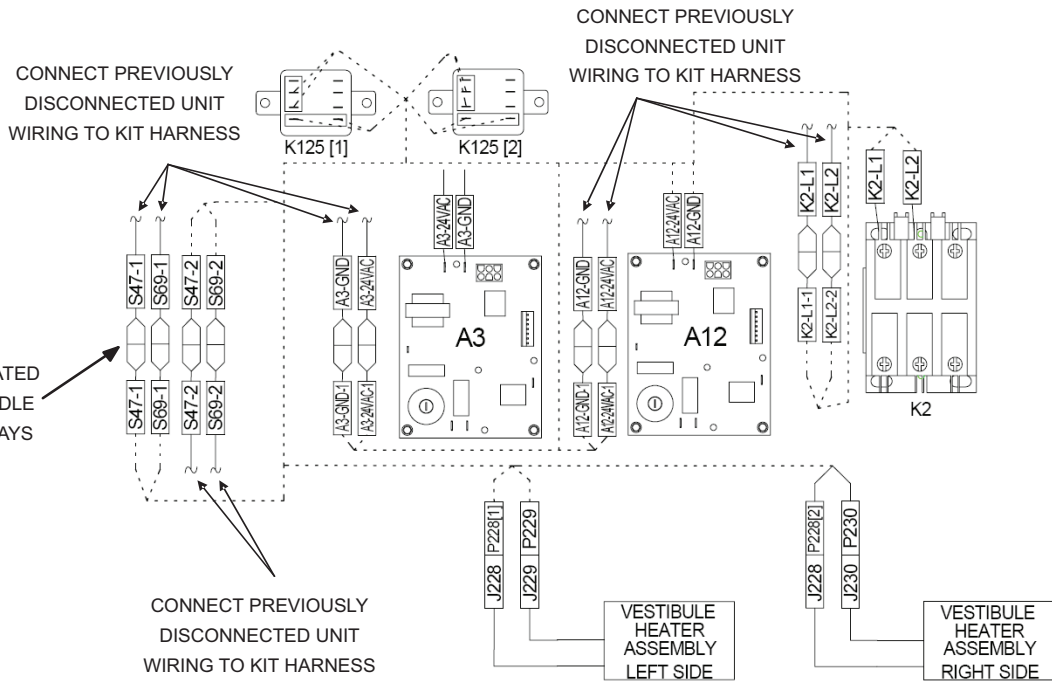
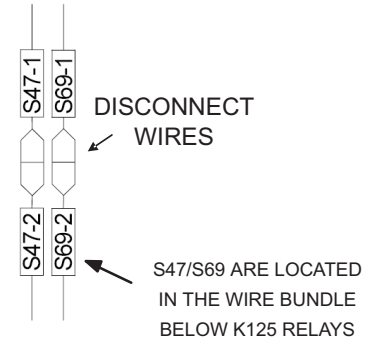
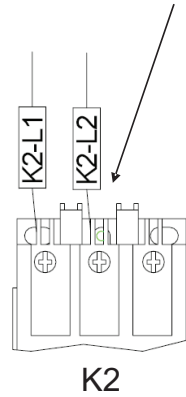
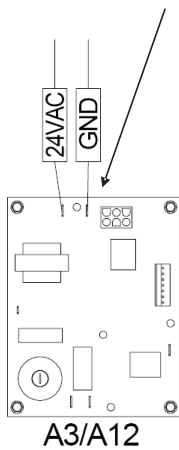

FIGURE 18

Installation - KG, KD 156-300 Units

- 1 - Disconnect all power to unit and open heat access panel.
- 2 - Install both cold weather assemblies as shown in figure 14. Use six thread forming screws, provided.
- 3 - Install both relays as shown in figure 19. Secure with #8 screws.

- 4 - Locate harness labeled 106648-01. Route as shown in figure 19. Secure with wire ties. Discard unused harnesses.
- 5 - Make wire connections as shown in figure 20 and 21.
- 6 - Use wire ties to securely route and tie harness away from gas heat manifold.
- 7 -

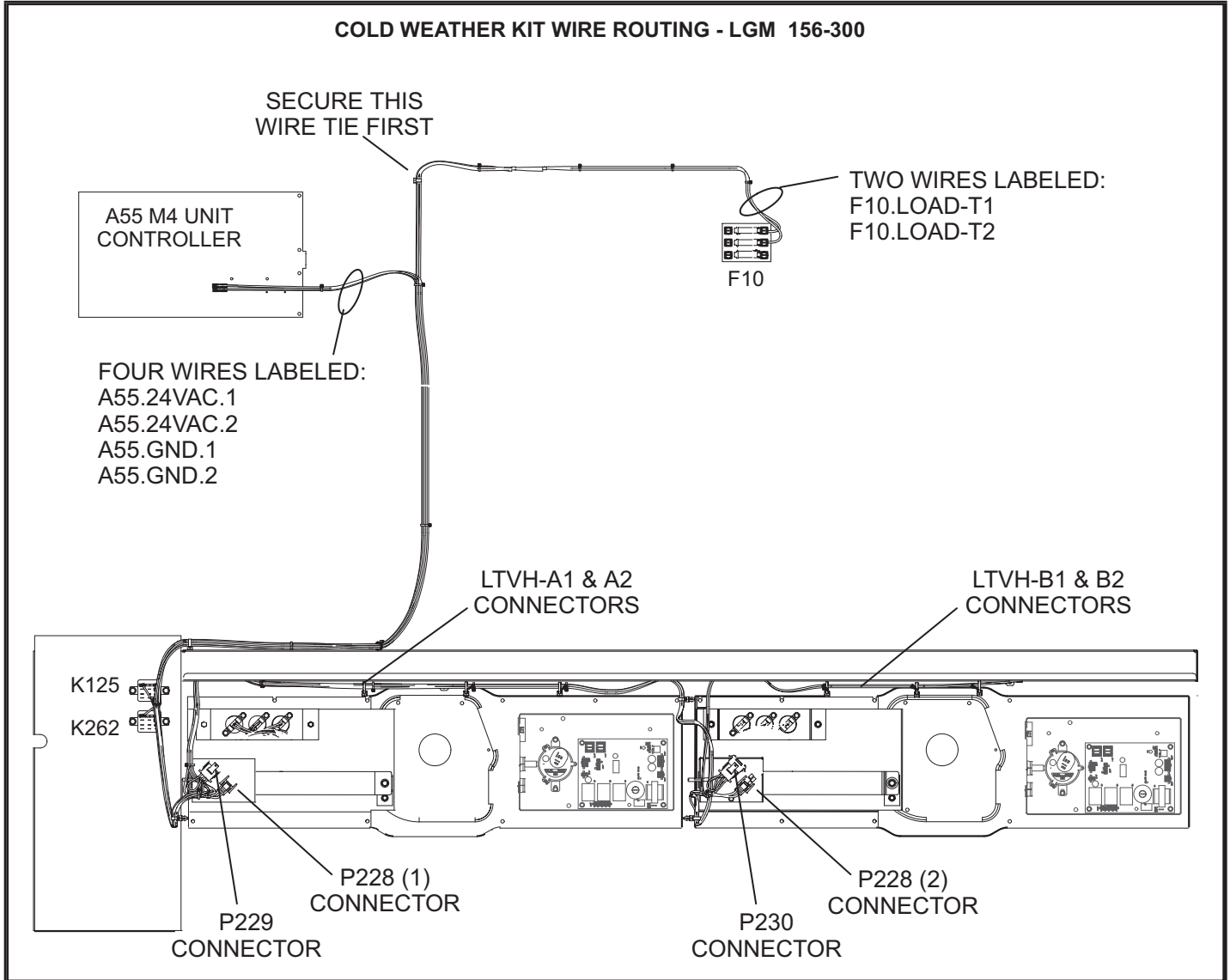
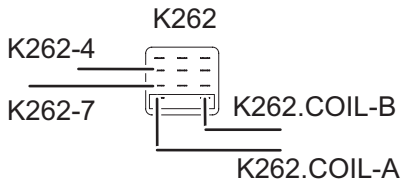
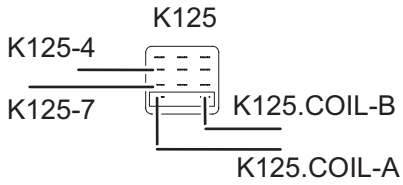
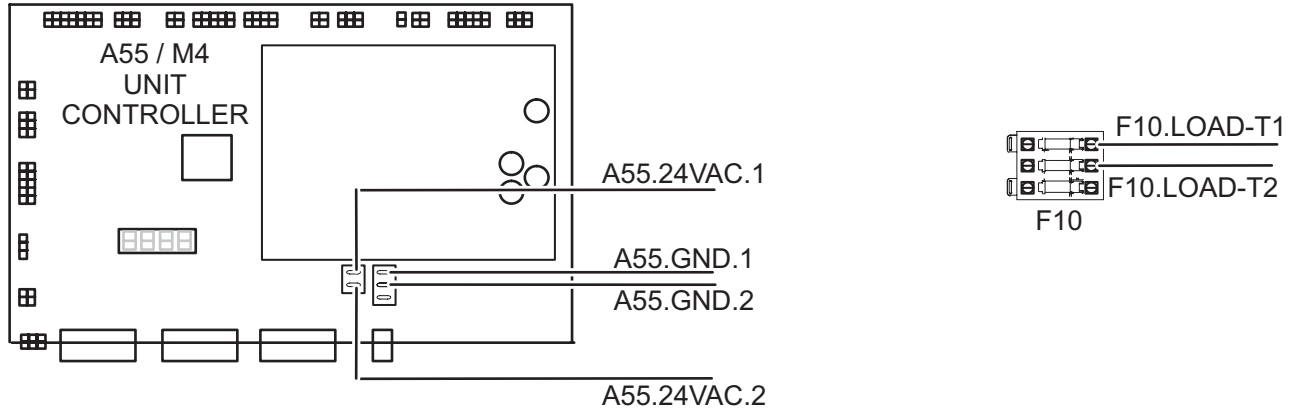

FIGURE 19

**COLD WEATHER KIT WIRING -
LGM156-300**



See figure 21 to connect control harness leads labeled:
LTVH-A1
LTVH-A2
LTVH-B1
LTVH-B2

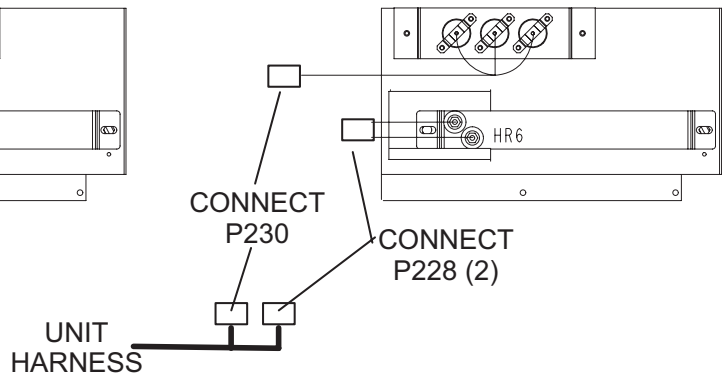
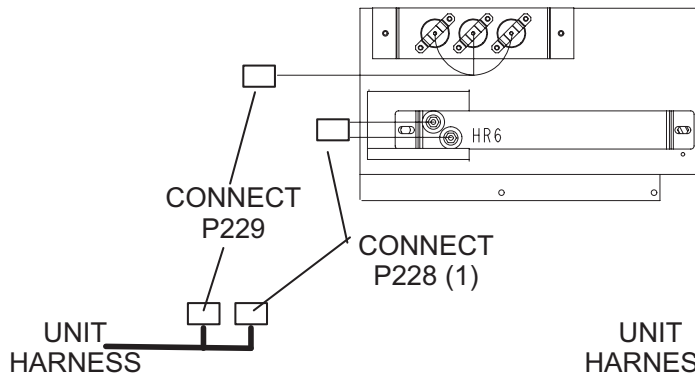

FIGURE 20

COLD WEATHER KIT WIRING - (continued)
LGM156-300

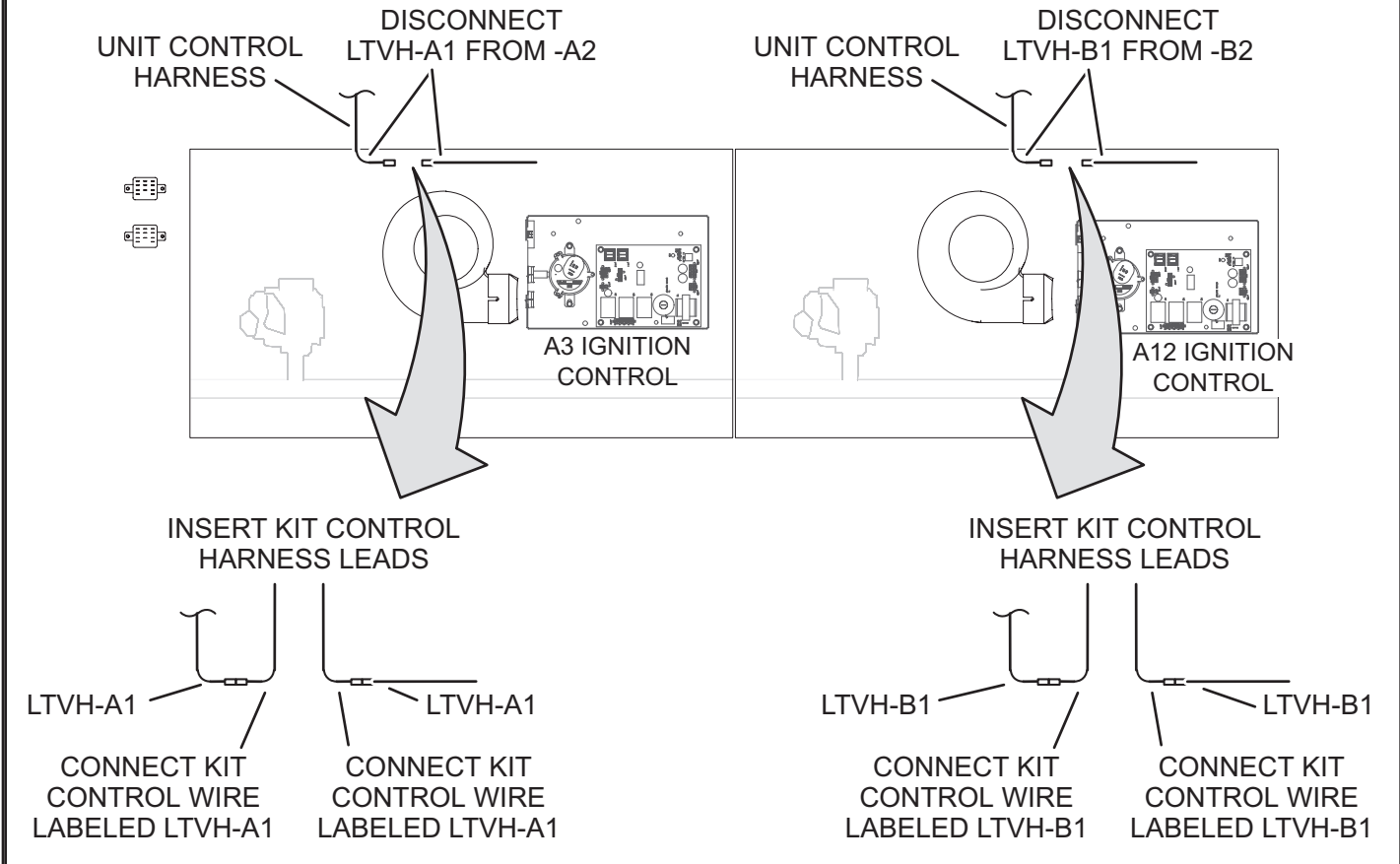

FIGURE 21

Installation - LGT/LDT/LGX/LDX 156-300 Units

- 1 - Disconnect all power to unit and open heat access panel.
- 2 - Install both cold weather assemblies as shown in figure 14. Use six thread forming screws, provided.
- 3 - Install both relays as shown in figure 22. Secure with #8 screws.
- 4 - Locate harness labeled 108303-01. Route as shown in figure 22. Secure with wire ties. Discard unused harnesses.
- 5 - Make wire connections as shown in figure 20 and 22.
- 6 - Use wire ties to securely route and tie harness away from hot surfaces (collector box cover, combustion blower, flue elbow, etc.).

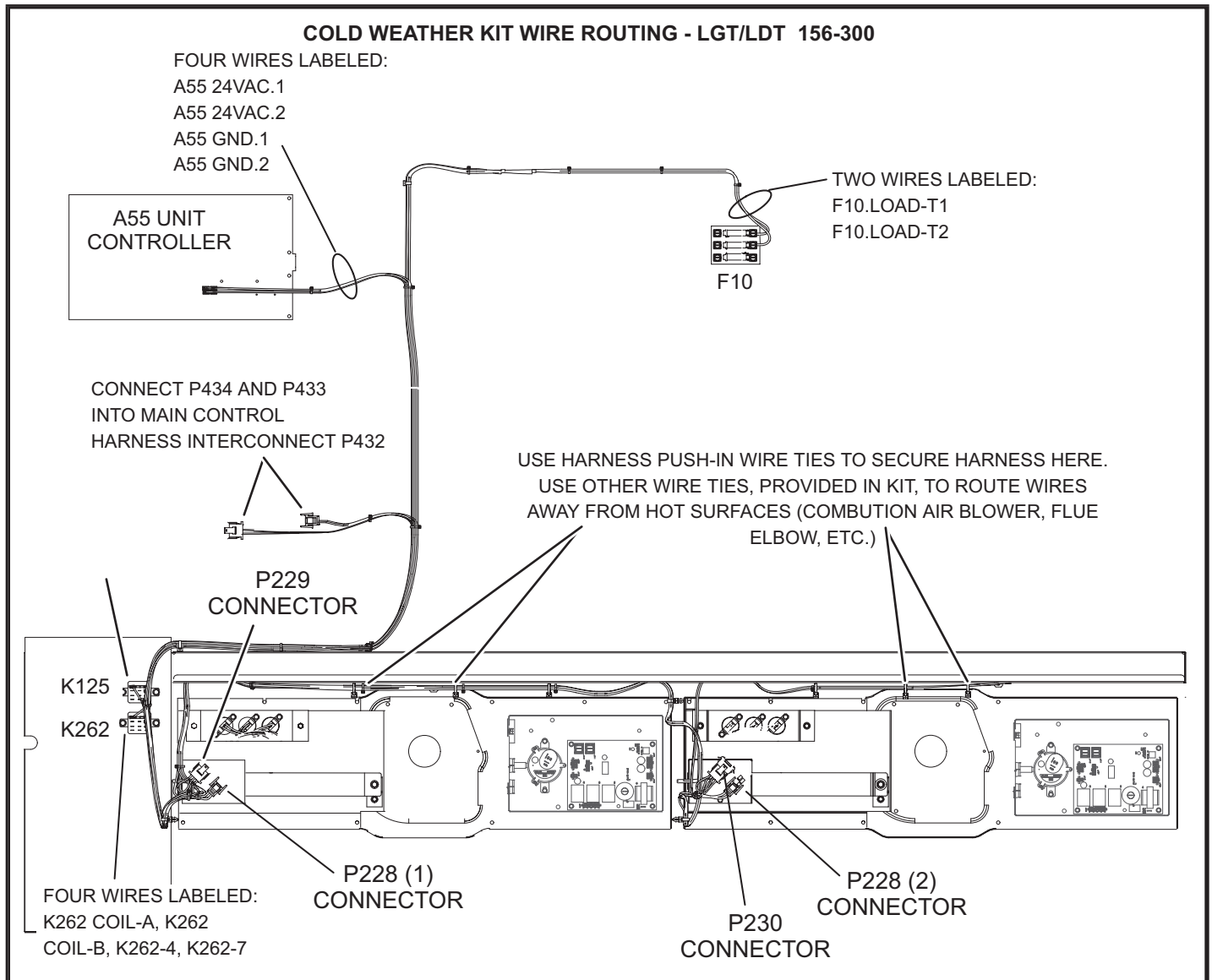

FIGURE 22