

# ROOFTOP UNIT KITS AND ACCESSORIES

508648-01  
12/2024

## INVERTER BYPASS KIT

### INSTALLATION INSTRUCTIONS FOR INVERTER BYPASS KIT (609165-04, 609165-05; 37G64, 37G65) USED WITH LCX/LGX/LHX 180-300 UNITS

#### Shipping and Packing List

##### 37G64 (609165-04)

Package 1 of 1 contains:

- 2- K3, K202 contactors
- 1- K203 relay
- 7- Harnesses
- 1- Bag assembly containing:
  - 6-#8-32 X 1/2 Thread forming screws
  - 3-Wire Ties
  - 1- Wiring Diagram (Label)

##### 37G65 (609165-05)

Package 1 of 1 contains:

- 2- K3, K202 contactor
- 1- K203 Relay
- 8- Harnesses
- 3- Overloads
- 1- Mounting bracket
- 1- Bag assembly containing:
  - 3-#8-32 X 1/2 Thread forming screws
  - 8-Wire ties
  - 1- Wiring Diagram (Label)

#### Application

The inverter bypass kit is used on units equipped with an inverter driven (VFD) blower motor. The inverter bypass kit can be used to operate the unit in single speed (CAV) blower mode if the inverter needs to be serviced or is not immediately available for replacement. See TABLE 1 for usage.

TABLE 1

Catalog No.	LC/LG/LHX Unit	Indoor Motor HP
37G64 609165-04	180-300	3, 5 and 7.5
37G65 609165-05	180-300	10

### WARNING

**Improper installation, adjustment, alteration, service or maintenance can cause property damage, personal injury or loss of life. Installation and service must be performed by a qualified installer, service agency or the gas supplier.**

#### Installation

Installation is shown in MSAV® mode, see FIGURE 1A; the inverter is not bypassed. See Change to VFD Bypass section to operate unit in CAV mode. See FIGURE 1B.

##### 37G64 KIT INSTALLATION FOR MOTORS WITH INTERNAL OVERLOAD PROTECTION

- 1 - Disconnect all power to unit.
- 2 - Install K3 blower contactor and K202 inverter contactor to the right of the inverter per FIGURE 1B.
- 3 - Unplug J423/P423 and P247/J247. Refer to factory wiring in FIGURE 1A. Carefully remove and discard the factory harness-1.

For the next steps Refer to FIGURE 1B (INVERTER BYPASS INSTALLED WIRING).

- 4 - Connect kit harness 1 labeled P249/K202.LINE between J247 and K202-LINE side per FIGURE 1B.
- 5 - Connect kit harness 2 labeled J249/K3.LOAD/K202.LOAD between P423, K3, and K202 per FIGURE 1B.

**NOTE** - Choose the correct harness based on the P423 connector type for the above 2 harnesses in step 4 & 5, as there are 2 sets of harnesses with the same label.

- 6 - Connect kit harness 3 labeled TB13/K3.LINE between TB13 and K3.LINE per FIGURE 1B.

For the next steps refer to FIGURE 3A, FIGURE 4A (FACTORY WIRING), FIGURE 3B, and FIGURE 4B (INVERTER BYPASS KIT WIRING-LOW VOLTAGE)

- 7 - Install K203. Disconnect factory harness-2 from board and then connect kit harness 6 labeled J392/K203-6,9 per FIGURE 3B.
- 8 - Connect kit harness 7 labeled P392/K203/K3/K202 per FIGURE 4B. Check all connections against FIGURE 5 before power ON.

##### 37G65 KIT INSTALLATION FOR MOTORS WITHOUT INTERNAL OVERLOAD PROTECTION

- 1 - Install K3 and K202. Connect kit harness 1 and 3 using the same method as 37G64 per FIGURE 1B. Connect kit harness 6, 7 per FIGURE 3B and FIGURE 4B.

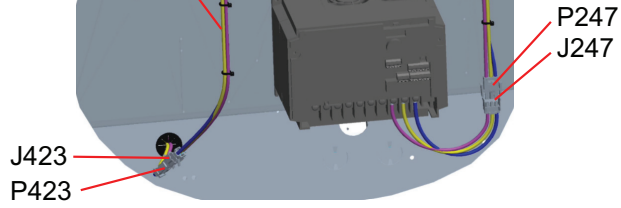
**NOTE** - Kit harness 2 is replaced by kit harness 5.

- 2 - Install S42 and connect kit harness-4 labeled P299B/S42/K3.LOAD, kit harness 5 labeled J249/S42.LOAD/K202.LOAD per FIGURE 2. Check all connections against FIGURE 5 before power ON.

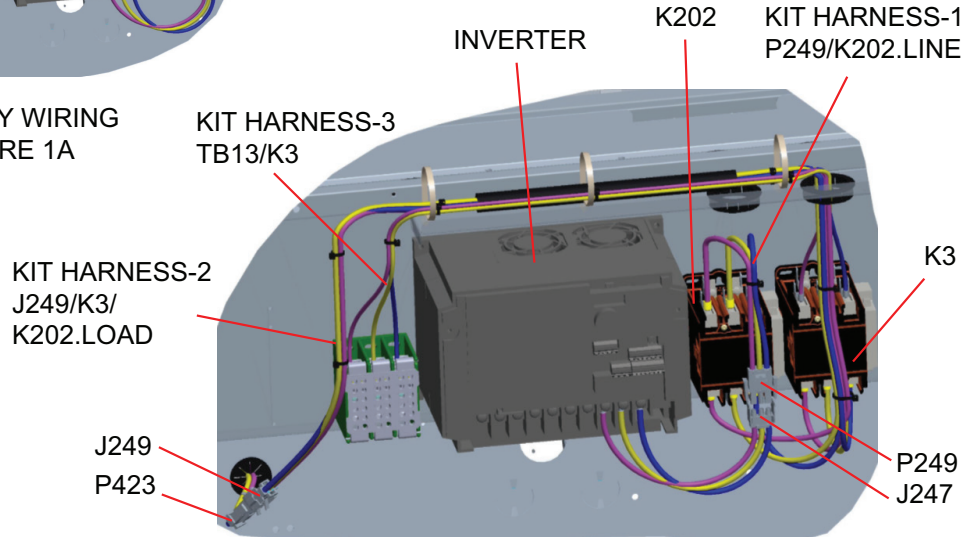


**37G64 KIT INSTALLATION - FOR MOTORS WITH INTERNAL OVERLOAD PROTECTION**

FACTORY HARNESS-1



FACTORY WIRING  
FIGURE 1A

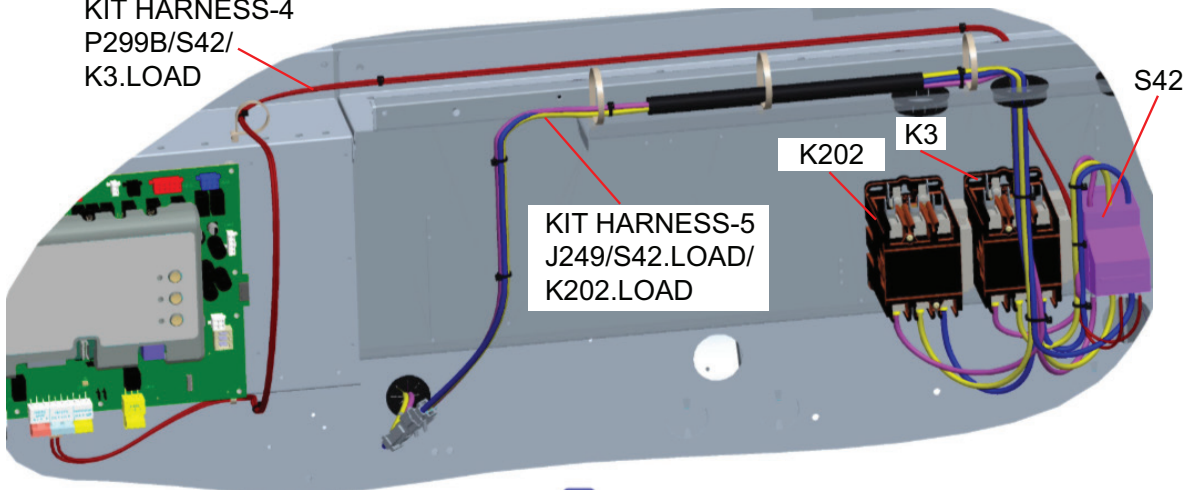


INVERTER BYPASS INSTALLED WIRING  
FIGURE 1B

**FIGURE 1**

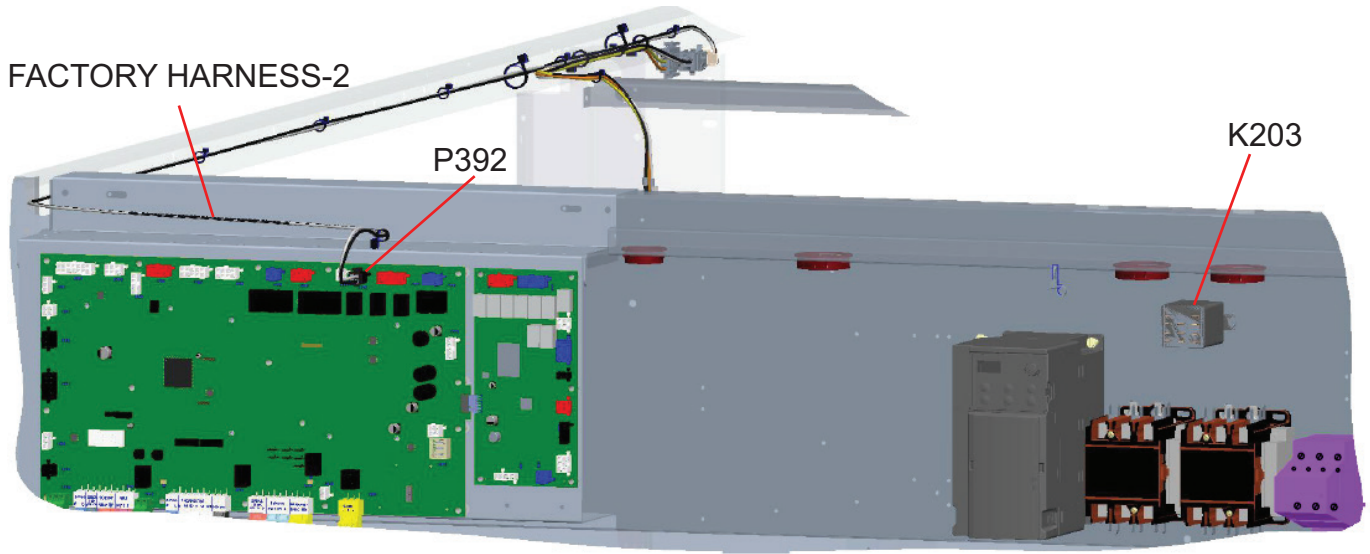
**37G65 KIT INSTALLATION - FOR BLOWER MOTORS WITHOUT INTERNAL OVERLOAD PROTECTION**

KIT HARNESS-4  
P299B/S42/  
K3.LOAD

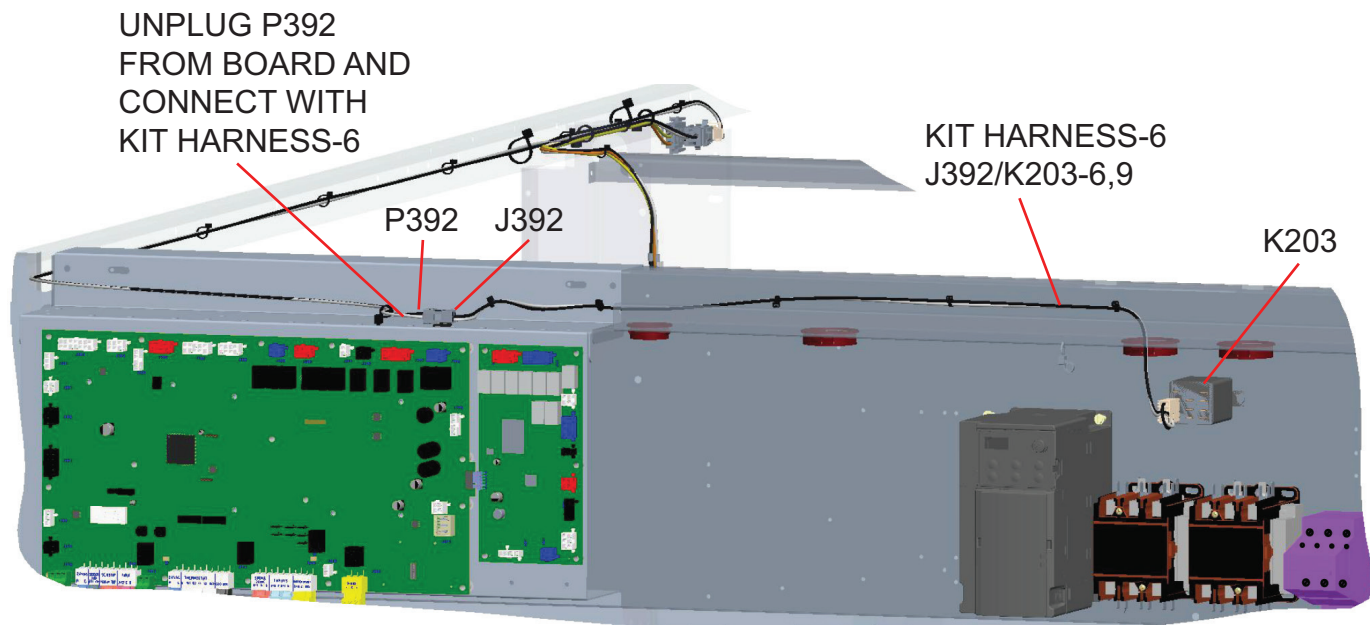


**FIGURE 2**

# 37G64 & 37G65 KIT INSTALLATION - LOW VOLTAGE CHANGE OVER



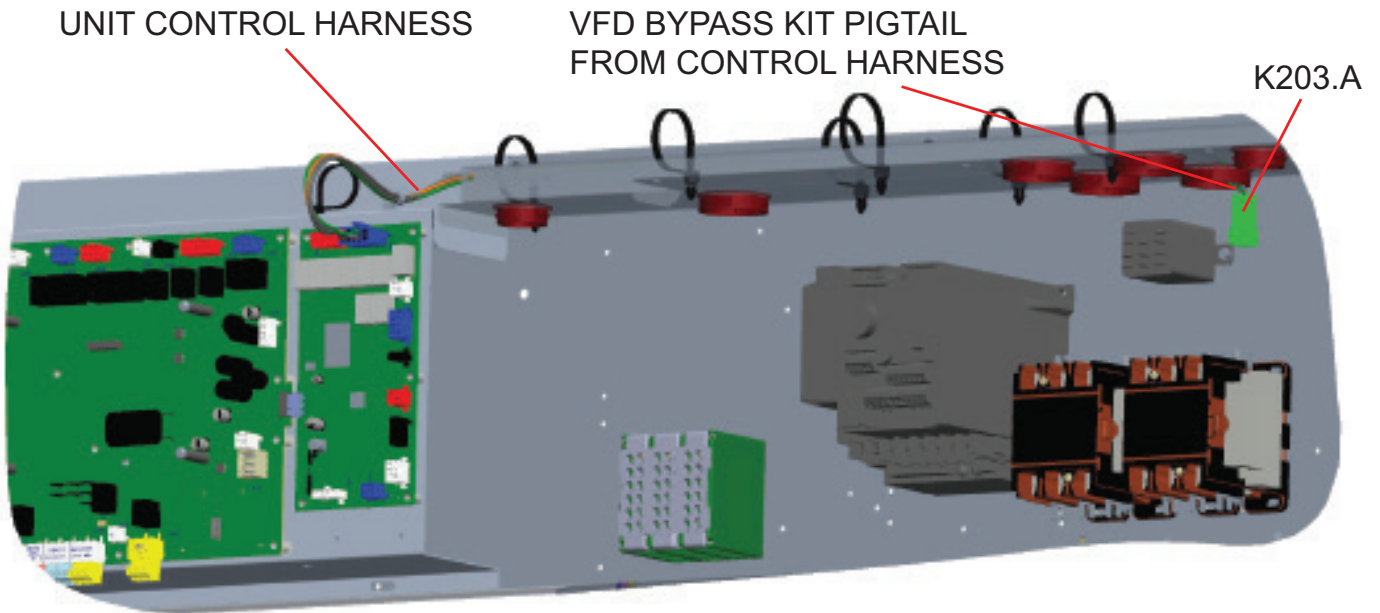
FACTORY WIRING  
FIGURE 3A



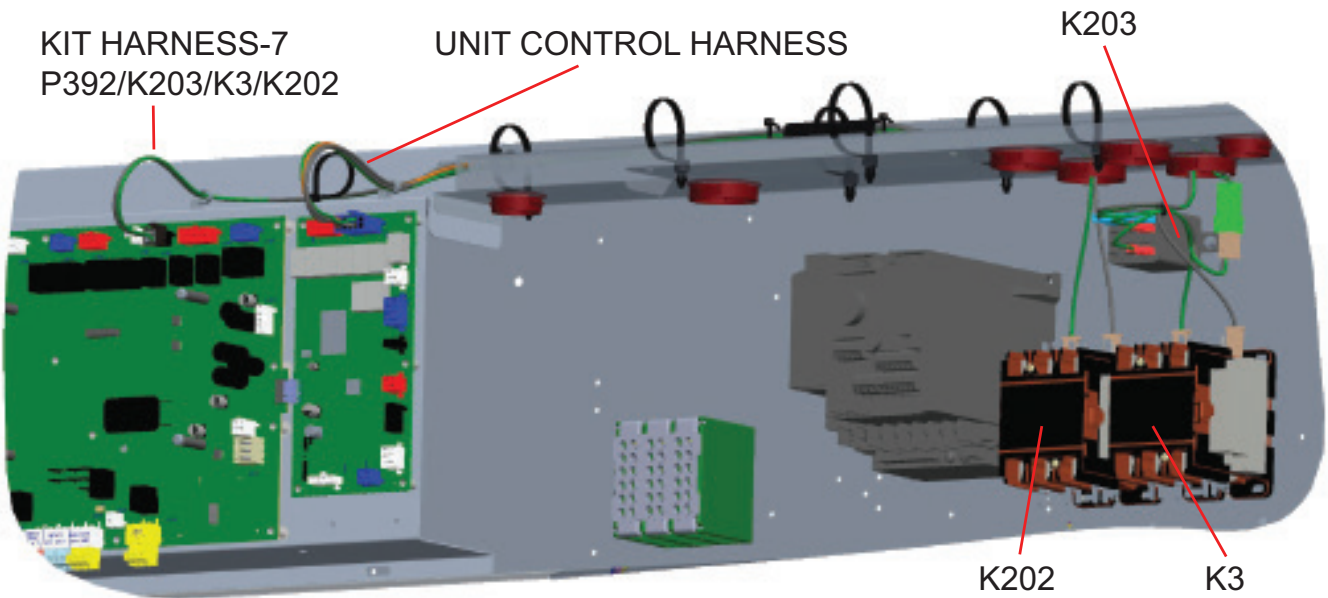
INVERTER BYPASS KIT WIRING-LOW VOLTAGE  
FIGURE 3B

FIGURE 3

# 37G64 & 37G65 KIT INSTALLATION - LOW VOLTAGE CHANGE OVER



FACTORY WIRING  
FIGURE 4A



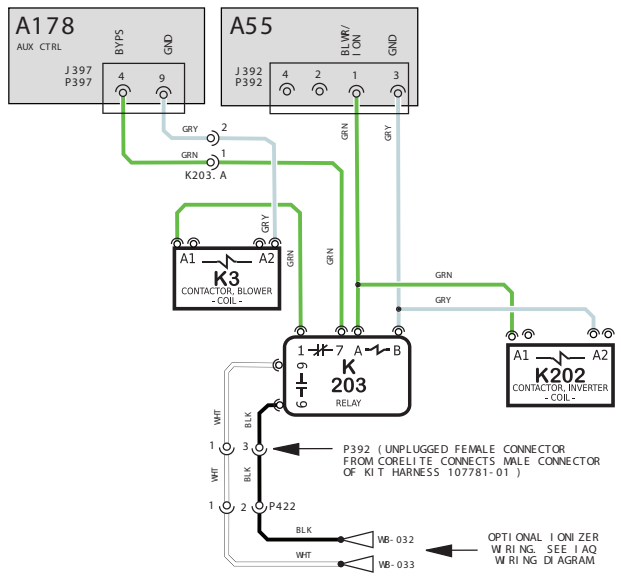
INVERTER BYPASS KIT WIRING-LOW VOLTAGE  
FIGURE 4B

FIGURE 4



AA BB CC DD EE FF

01

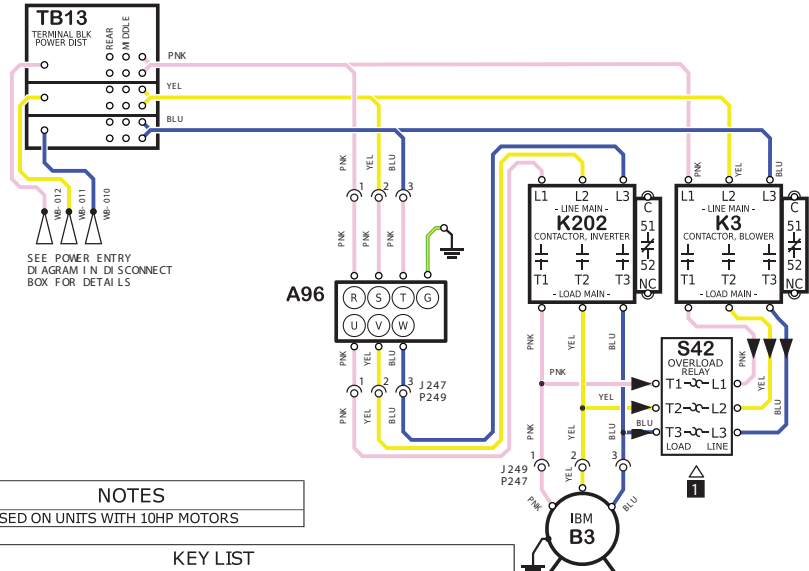


02

03

04

05



06

07

08

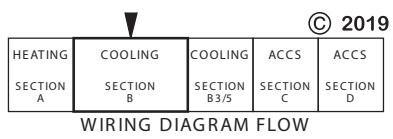
**NOTES**  
1 S42 USED ON UNITS WITH 10HP MOTORS

09

KEY LIST	
LOCATION	COMPONENT DESCRIPTION
CC07	A96 CONTROL INVERTER, BLOWER
EE08	B3 MOTOR, BLOWER
BB02/EE06	K3 CONTACTOR, BLOWER
DD03/06	K202 CONTACTOR, INVERTER
CC03	K203 RELAY, INVERTER CONTROL
EE07	S42 OVERLOAD, RELAY, BLOWER MOTOR
AA05	TB13 TERMINAL STRIP, POWER DISTRIBUTION

10

Model: LCX, LGX, LHX 1805, 2105, 2405, 3005  
MSAV - VFD BYPASS KIT  
Voltage: ALL VOLTAGES  
Supersedes: N/A Form No: 538544- 01 Rev: 0



REV	EC NO.	DATE	BY	APVD	REVISION NOTE
---	CN-012404A	05-10-2024	DEV	JAL21	ORIGINATED AT PD&R CARROLLTON, TX

FIGURE 5