

UNIT INFORMATION

LCT SERIES 7.5 to 12.5 ton

100146

Service Literature

LCT092H through 150H with R-454B

The LCT092H-150H units are configured to order units (CTO) with a wide selection of factory-installed options.

Cooling capacities range from 7.5 to 12.5 tons. All units are equipped with two compressors.

Optional electric heat is factory- or field-installed. Electric heat operates in single or multiple stages depending on the kW input size. 7.5kW to 45kW heat sections are available for the 092 & 102 and 15kW to 60kW heat sections are available for 120 & 150.

Units are available with direct drive blower. The blower will operate at lower speeds when demand is low and increase to higher speeds when demand is high.

All units come standard with a lightweight, all-aluminum condenser coil, one two stage compressor and one single stage compressor.

All LCT units are designed to accept any of several different energy management thermostat control systems with minimum field wiring. Factory or field provided control options connect to the unit with jack plugs. When "plugged in" the controls become an integral part of the unit wiring.

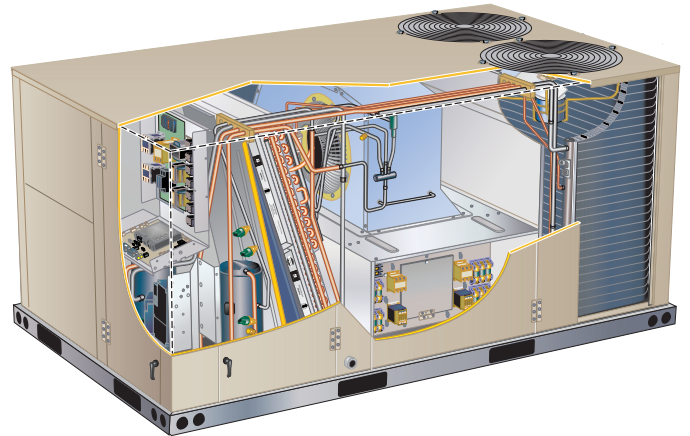

False ceilings or drop ceiling may be used as a return air plenum only if the unit being installed has a Refrigerant Detection System installed.

All maintenance staff and others working in the local area shall be instructed on the nature of work being carried out with work in confined spaces being avoided.

Ensure that the area is in the open or that it is adequately ventilated before breaking into the system or conducting any hot work. A degree of ventilation shall continue during the period that the work is carried out. The ventilation should safely disperse any released refrigerant and preferably expel it externally into the atmosphere.

Table of Contents

Options / Accessories	Page 3
Specifications	Page 6
Blower Tables	Page 8
Electrical / Electric Heat Data	Page 11
Parts Arrangement	Page 16
I-Unit Components	Page 17
II-Placement and Installation	Page 31
III-Charging	Page 31
IV-Start Up - Operation	Page 37
V-System Service Checks	Page 37
VI-Accessories	Page 37
VII-Direct Drive Supply Air Blower	Page 45
VIII-Staged Supply Air Operation.	Page 46
IX-Maintenance	Page 47
X- Wiring and Operation Sequence	Page 49
XI Decommissioning	Page 60

⚠ WARNING

Do not use means to accelerate the defrosting process or to clean, other than those recommended by the manufacturer.

The appliance shall be stored in a room without continuously operating ignition sources (for example: open flames, an operating gas appliance, or an operating electric heater).

Do not pierce or burn.

Be aware that refrigerants may not contain an odor.

⚠ WARNING

If this appliance is conditioning a space with an area smaller than TA min or stored in a space with an area smaller than A min as defined by this instruction, then that space must be without continuously operating open flames (e.g. an operating gas appliance) or other potential ignition sources (e.g. an operating electric heater or similar hot surface). A flame-producing device may be installed in the same space if the device is provided with an effective flame arrest system.

⚠ WARNING

Auxiliary devices which may be potential ignition sources shall not be installed in the duct work. Examples of potential ignition sources are hot surfaces with a temperature exceeding 700°C and electric switching components.

⚠ WARNING

To prevent serious injury or death:

- 1- Lock-out/tag-out before performing maintenance.
- 2- If system power is required (e.g., smoke detector maintenance), disable power to blower, remove fan belt where applicable, and ensure all controllers and thermostats are set to the "OFF" position before performing maintenance.
- 3- Always keep hands, hair, clothing, jewelry, tools, etc., away from moving parts.

⚠ WARNING

Only Manufacturer approved auxiliary devices are permitted to be installed in this unit.

⚠ CAUTION

Any service personnel installing, decommissioning, or performing maintenance on the unit must be properly trained with A2L refrigerants.

⚠ WARNING



Electric shock hazard. Can cause injury or death. Before attempting to perform any service or maintenance, turn the electrical power to unit OFF at disconnect switch(es). Unit may have multiple power supplies.

⚠ WARNING

Improper installation, adjustment, alteration, service or maintenance can cause property damage, personal injury or loss of life. Installation and service must be performed by a licensed professional HVAC installer or equivalent, service agency, or the gas supplier.

⚠ CAUTION

As with any mechanical equipment, contact with sharp sheet metal edges can result in personal injury. Take care while handling this equipment and wear gloves and protective clothing.

⚠ WARNING

- This appliance must be installed in accordance with local and national wiring regulations.
- If the appliance is not fitted with an option for full disconnection from power, a means of disconnection must be incorporated in the fixed wiring in accordance with national and local wiring regulations.

⚠ CAUTION

The appliance is not to be used by persons (including children) with reduced physical, sensory or mental capabilities, or lack of experience and knowledge, unless they have been given supervision or instruction

⚠ CAUTION

Children should be supervised not to play with the appliance.

⚠ CAUTION

Servicing shall be performed only as recommended by the manufacturer.

⚠ CAUTION

Leak Detection System installed. Unit must be powered except for service.

⚠ WARNING

Ducts connected to an appliance shall not contain a potential ignition source.

⚠ IMPORTANT

Pipe work, including piping material, pipe routing, and installation shall include protection from physical damage in operation and service, and be in compliance with national and local codes and standards, such as ASHRAE 15, ASHRAE 15.2, IAPMO Uniform Mechanical Code, ICC International Mechanical Code, or CSA B52. All field joints shall be accessible for inspection prior to being covered or enclosed.

⚠ IMPORTANT

Refrigerant sensors for refrigerant detection systems shall only be replaced with sensors specified by the appliance manufacture.

⚠ CAUTION

This unit is equipped with electrically powered safety measures. To be effective, the unit must be electrically powered at all times after installation, other than when servicing.

OPTIONS / ACCESSORIES

Item Description	Catalog Number	Unit Model No				
		092	102	120	150	
COOLING SYSTEM						
Condensate Drain Trap	PVC	22H54	OX	OX	OX	OX
	Copper	76W27	X	X	X	X
Drain Pan Overflow Switch		21Z07	OX	OX	OX	OX
BLOWER - SUPPLY AIR						
Blower Option	DirectPlus™ Blower System with MSAV®	Factory	O	O	O	O
	DirectPlus™ Blower System with VAV	Factory	O	O	O	O
CABINET						
Combination Coil/Hail Guards		24C85	OX	OX	OX	OX
Corrosion Protection		Factory	O	O	O	O
Horizontal Discharge Kit		51W25	X	X	X	X
Return Air Adaptor Plate (for LC/LG/LH and TC/TG/TH unit replacement)		54W96	OX	OX	OX	OX
CONTROLS						
Commercial Controls	LonTalk® Module	54W27	OX	OX	OX	OX
	Novar® LSE	Factory	O	O	O	O
Dirty Filter Switch		53W67	OX	OX	OX	OX
Fresh Air Tempering		21Z08	OX	OX	OX	OX
Smoke Detector - Supply or Return (Power board and one sensor)		31A68	OX	OX	OX	OX
Smoke Detector - Supply and Return (Power board and two sensors)		31A69	OX	OX	OX	OX
INDOOR AIR QUALITY						
Air Filters						
Healthy Climate® High Efficiency Air Filters 20 x 25 x 2 in. (Order 4 per unit)	MERV 8	50W61	OX	OX	OX	OX
	MERV 13	52W41	OX	OX	OX	OX
	MERV 16	21U41	X	X	X	X
Replacement Media Filter With Metal Mesh Frame (includes non-pleated filter media)		Y3063	X	X	X	X
Indoor Air Quality (CO₂) Sensors						
Sensor - Wall-mount, off-white plastic cover with LCD display		24C58	X	X	X	X
Sensor - Wall-mount, off-white plastic cover, no display		23V86	X	X	X	X
Sensor - Black plastic case with LCD display, rated for plenum mounting		87N52	X	X	X	X
Sensor - Wall-mount, black plastic case, no display, rated for plenum mounting		23V87	X	X	X	X
CO ₂ Sensor Duct Mounting Kit - for downflow applications		23Y47	X	X	X	X
Aspiration Box - for duct mounting non-plenum rated CO ₂ sensors (24C58)		90N43	X	X	X	X
Needlepoint Bipolar Ionization (NPBI)						
Needlepoint Bipolar Ionization (NPBI) Kit		22U15	X	X	X	X
UVC Germicidal Lamps						
¹ Healthy Climate® UVC Light Kit (110/230v-1ph)		21A93	X	X	X	X
Step-Down Transformers	460V primary, 230V secondary	10H20	X	X	X	X
	575V primary, 230V secondary	10H21	X	X	X	X

¹ Lamps operate on 110-230V single-phase power supply. Step-down transformer may be ordered separately for 460V and 575V units. Alternately, 110V power supply may be used to directly power the UVC ballast(s).

NOTE - Catalog numbers shown are for ordering field installed accessories.

OX = Configure To Order (Factory Installed) or Field Installed.

O = Configure To Order (Factory Installed).

X = Field Installed.

OPTIONS / ACCESSORIES

Item Description	Catalog Number	Unit Model No				
		092	102	120	150	
ELECTRICAL						
Voltage 60 Hz	208/230V - 3 phase	Factory	O	O	O	O
	460V - 3 phase	Factory	O	O	O	O
	575V - 3 phase	Factory	O	O	O	O
HACR Circuit Breakers		Factory	O	O	O	O
Disconnect Switch - See Electrical/Electric Heat tables for selection	80 amp	54W56	OX	OX	OX	OX
	150 amp	54W57	OX	OX	OX	OX
¹ Short-Circuit Current Rating (SCCR) of 100kA (includes Phase/Voltage Detection)		Factory	O	O	O	O
GFI Service Outlets	15 amp non-powered, field-wired (208/230V, 460V only)	74M70	OX	OX	OX	OX
	15 amp factory-wired and powered (208/230V, 460V)	Factory	O	O	O	O
	² 20 amp non-powered, field-wired (208/230V, 460V, 575V)	67E01	X	X	X	X
	² 20 amp non-powered, field-wired (575V only)	Factory	O	O	O	O
Weatherproof Cover for GFI		10C89	X	X	X	X
ELECTRIC HEAT						
7.5 kW	208/240V-3ph	30U33	OX	OX		
	460V-3ph	30U34	OX	OX		
	575V-3ph	30U35	OX	OX		
15 kW	208/240V-3ph	30U36	OX	OX	OX	OX
	460V-3ph	30U37	OX	OX	OX	OX
	575V-3ph	30U38	OX	OX	OX	OX
22.5 kW	208/240V-3ph	30U39	OX	OX	OX	OX
	460V-3ph	30U40	OX	OX	OX	OX
	575V-3ph	30U41	OX	OX	OX	OX
30 kW	208/240V-3ph	30U42	OX	OX	OX	OX
	460V-3ph	30U43	OX	OX	OX	OX
	575V-3ph	30U44	OX	OX	OX	OX
45 kW	208/240V-3ph	30U45	OX	OX	OX	OX
	460V-3ph	30U46	OX	OX	OX	OX
	575V-3ph	30U47	OX	OX	OX	OX
60 kW	208/240V-3ph	30U48			OX	OX
	460V-3ph	30U49			OX	OX
	575V-3ph	30U50			OX	OX

¹ Disconnect Switch not available with SCCR option.

SCCR option is only available with factory installed electric heat or no electric.

² Canada requires a minimum 20 amp circuit. Select 20 amp, non-powered, field wired GFI.

NOTE - Catalog numbers shown are for ordering field installed accessories.

OX = Configure To Order (Factory Installed) or Field Installed.

O = Configure To Order (Factory Installed).

X = Field Installed.

OPTIONS / ACCESSORIES

Item Description	Catalog Number	Unit Model No			
		092	102	120	150
ECONOMIZER					
High Performance Economizer (Approved for California Title 24 Building Standards / AMCA Class 1A Certified)					
High Performance Economizer (Downflow or Horizontal) Includes Economizer Dampers with Outdoor Air Hood and Barometric Relief Dampers with Exhaust Hood Downflow Applications - Use furnished Outdoor Air Hood and Barometric Relief Dampers with Exhaust Hood Horizontal Applications - Use furnished Outdoor Air Hood and Barometric Relief Dampers with Exhaust Hood - Order Horizontal Discharge Kit separately Horizontal Applications (reduced height) - Order Horizontal Low Profile Barometric Relief Dampers with Exhaust Hood and Horizontal Discharge Kit (51W25) separately	20U80	OX	OX	OX	OX
Horizontal Barometric Relief Dampers					
Horizontal Low Profile Barometric Relief Dampers (Exhaust hood furnished)	53K04	X	X	X	X
Economizer Controls					
Differential Enthalpy (Not for Title 24)	Order 2 21Z09	OX	OX	OX	OX
Sensible Control	Sensor is Furnished Factory	O	O	O	O
Single Enthalpy (Not for Title 24)	21Z09	OX	OX	OX	OX
Building Pressure Control	13J77	X	X	X	X
Outdoor Air CFM Control	13J76	X	X	X	X
Global Control	Sensor Field Provided Factory	O	O	O	O
OUTDOOR AIR					
Outdoor Air Dampers With Outdoor Air Hood					
Motorized	14G28	OX	OX	OX	OX
Manual	14G29	X	X	X	X
POWER EXHAUST					
Standard Static	208/230V-3ph 53W44	OX	OX	OX	OX
	460V-3ph 53W45	OX	OX	OX	OX
	575V-3ph 53W46	OX	OX	OX	OX
HUMIDITROL® CONDENSER REHEAT OPTION					
Humiditrol Dehumidification Option	Factory	O	O	O	O
ROOF CURBS					
Hybrid Roof Curbs, Downflow					
8 in. height	11F54	X	X	X	X
14 in. height	11F55	X	X	X	X
18 in. height	11F56	X	X	X	X
24 in. height	11F57	X	X	X	X
Adjustable Pitch Curb					
14 in. height	54W50	X	X	X	X
CEILING DIFFUSERS					
Step-Down - Order one	RTD11-95S 13K61	X			
	RTD11-135S 13K62		X	X	
	RTD11-185S 13K63				X
Flush - Order one	FD11-95S 13K56	X			
	FD11-135S 13K57		X	X	
	FD11-185S 13K58				X
Transitions (Supply and Return) - Order one	C1DIFF30B-1 12X65	X			
	C1DIFF31B-1 12X66		X	X	
	C1DIFF32B-1 12X67				X

NOTE - Catalog numbers shown are for ordering field installed accessories.

OX = Configure To Order (Factory Installed) or Field Installed.

O = Configure To Order (Factory Installed).

X = Field Installed.

SPECIFICATIONS			MSAV MODELS			
Model			LCT092H5E	LCT102H5E	LCT120H5E	LCT150H5E
Nominal Tonnage			7.5 Ton	8.5 Ton	10 Ton	12.5 Ton
Efficiency Type			High	High	High	High
Blower Type			DirectPlus™ ECM Direct Drive with MSAV®	DirectPlus™ ECM Direct Drive with MSAV®	DirectPlus™ ECM Direct Drive with MSAV®	DirectPlus™ ECM Direct Drive with MSAV®
Cooling Performance	Gross Cooling Capacity - Btuh		94,000	103,000	121,000	142,000
	¹ Net Cooling Capacity - Btuh		92,000	100,000	118,000	138,000
	¹ AHRI Rated Air Flow - cfm		3000	3400	3400	4100
	¹ IEER (Btuh/Watt)		16.3	16.3	16.3	15.4
	¹ EER (Btuh/Watt)		12.5	12.3	12.3	11.0
	Total Unit Power (kW))		7.5	7.9	9.8	12.6
Sound Rating Number	dBA		88	88	89	89
Refrigerant Charge	Refrigerant Type		R-454B	R-454B	R-454B	R-454B
	Without Reheat Option	Circuit 1	6 lbs. 4 oz.	6 lbs. 4 oz.	5 lbs. 14 oz.	5 lbs. 12 oz.
		Circuit 2	5 lbs. 14 oz.	5 lbs. 14 oz.	5 lbs. 14 oz.	6 lbs. 4 oz.
	With Reheat Option	Circuit 1	6 lbs. 8 oz.	6 lbs. 8 oz.	6 lbs. 4 oz.	6 lbs. 2 oz.
		Circuit 2	5 lbs. 14 oz.	5 lbs. 14 oz.	5 lbs. 14 oz.	6 lbs. 4 oz.
Electric Heat Available - See page 28			7.5, 15, 22.5, 30 & 45 kW		15, 22.5, 30, 45 & 60 kW	
Compressor Type (number)			Two-Stage Scroll (1) Single-Stage Scroll (1)			
Outdoor Coil	Net face area (total) - sq. ft.		27.5	27.5	27.5	27.5
	Number of rows		1	1	1	1
	Fins per inch		20	20	20	20
Outdoor Coil Fans	Motor HP (number and type)		1/3 (2 PSC)	1/3 (2 PSC)	1/2 (2 PSC)	1/2 (2 PSC)
	Rpm		1075	1075	1075	1075
	Watts (total)		860	860	1000	1000
	Diameter (Number) - in.		(2) 24	(2) 24	(2) 24	(2) 24
	Blades		3	3	3	3
	Total Air volume - cfm		9000	9000	9700	9700
	Indoor Coil	Net face area - ft. ² (total)		13.54	13.54	13.54
Tube diameter - in.		3/8	3/8	3/8	3/8	
Rows		4	4	4	4	
Fins - in.		14	14	14	14	
Condensate drain size (NPT) - in.		(1) 1				
Expansion device type		Balanced Port Thermostatic Expansion Valve,removable power element				
Indoor Blower	Motor HP (number and type)		3.75 (1 ECM)	3.75 (1 ECM)	3.75 (1 ECM)	3.75 (1 ECM)
	Wheel (Number) diameter x width - in.		(1) 22 x 9	(1) 22 x 9	(1) 22 x 9	(1) 22 x 9
Filters	Type of filter		MERV 4, Disposable			
	Number and size - in.		(4) 20 x 25 x 2			
Line voltage data (Volts-Phase-Hz)			208/230-3-60, 460-3-60, 575-3-60			

NOTE - Net capacity includes evaporator blower motor heat deduction. Gross capacity does not include evaporator blower motor heat deduction.

¹ AHRI Certified to AHRI Standard 340/360; 95°F outdoor air temperature and 80°F db/67°F wb entering evaporator air; minimum external duct static pressure.

SPECIFICATIONS		VAV MODELS				
Model		LCT092H5P	LCT102H5P	LCT120H5P	LCT150H5P	
Nominal Tonnage		7.5 Ton	8.5 Ton	10 Ton	12.5 Ton	
Efficiency Type		High	High	High	High	
Blower Type		DirectPlus™ ECM Direct Drive with VAV	DirectPlus™ ECM Direct Drive with VAV	DirectPlus™ ECM Direct Drive with VAV	DirectPlus™ ECM Direct Drive with VAV	
Cooling Performance	Gross Cooling Capacity - Btuh	94,000	103,000	121,000	142,000	
	¹ Net Cooling Capacity - Btuh	92,000	100,000	118,000	138,000	
	¹ AHRI Rated Air Flow - cfm	3000	3400	3400	4100	
	¹ IEER (Btuh/Watt)	15.7	15.7	15.7	14.6	
	¹ EER (Btuh/Watt)	12.5	12.3	12.3	11.0	
	Total Unit Power (kW)	7.5	7.9	9.8	12.6	
Sound Rating Number	dBA	88	88	89	89	
Refrigerant Charge	Refrigerant Type	R-454B	R-454B	R-454B	R-454B	
	Without Reheat Option	Circuit 1	6 lbs. 4 oz.	6 lbs. 4 oz.	5 lbs. 14 oz.	5 lbs. 12 oz.
		Circuit 2	5 lbs. 14 oz.	5 lbs. 14 oz.	5 lbs. 14 oz.	6 lbs. 4 oz.
Electric Heat Available		7.5, 15, 22.5, 30 & 45 kW		15, 22.5, 30, 45 & 60 kW		
Compressor Type (number)		Two-Stage Scroll (1) Single-Stage Scroll (1)				
Outdoor Coil	Net face area - ft. ² (total)	27.5	27.5	27.5	27.5	
	Rows	1	1	1	1	
	Fins - in.	20	20	20	20	
Outdoor Coil Fans	Motor (number) HP (type)	(2) 1/3 (PSC)	(2) 1/3 (PSC)	(2) 1/2 (PSC)	(2) 1/2 (PSC)	
	Rpm	1075	1075	1075	1075	
	Watts (total)	860	860	1000	1000	
	Diameter (Number) - in.	(2) 24	(2) 24	(2) 24	(2) 24	
	Blades	3	3	3	3	
	Total Air volume - cfm	9000	9000	9700	9700	
Indoor Coil	Net face area - ft. ² (total)	13.54	13.54	13.54	13.54	
	Tube diameter - in.	3/8	3/8	3/8	3/8	
	Rows	4	4	4	4	
	Fins - in.	14	14	14	14	
	Condensate drain size (NPT) - in.	(1) 1				
Expansion device type	Balanced Port Thermostatic Expansion Valve, removable power element					
Indoor Blower	Motor HP (number and type)	3.75 (1 ECM)	3.75 (1 ECM)	3.75 (1 ECM)	3.75 (1 ECM)	
	Wheel (Number) diameter x width - in.	(1) 22 x 9	(1) 22 x 9	(1) 22 x 9	(1) 22 x 9	
Filters	Type of filter	MERV 4, Disposable				
	Number and size - in.	(4) 20 x 25 x 2				
Line voltage data (Volts-Phase-Hz)		208/230-3-60, 460-3-60, 575-3-60				

NOTE - Net capacity includes evaporator blower motor heat deduction. Gross capacity does not include evaporator blower motor heat deduction.

¹ AHRI Certified to AHRI Standard 340/360; 95°F outdoor air temperature and 80°F db/67°F wb entering evaporator air; minimum external duct static pressure.

BLOWER DATA

BLOWER TABLE INCLUDES RESISTANCE FOR BASE UNIT ONLY (NO HEAT SECTION) WITH DRY INDOOR COIL AND AIR FILTERS IN PLACE.

FOR ALL UNITS ADD:

- 1 – Wet indoor coil air resistance of selected unit.
 - 2 – Any factory installed options air resistance (heat section, Economizer, etc.)
 - 3 – Any field installed accessories air resistance (duct resistance, diffuser, etc.)
- See page 9 for wet coil and option/accessory air resistance data.
See page 9 for minimum air volume required for use with optional electric heat.

Total Air Volume cfm	Total Static Pressure - in. w.g.													
	0.2		0.4		0.6		0.8		1.0		1.2		1.4	
	RPM	Watts	RPM	Watts	RPM	Watts	RPM	Watts	RPM	Watts	RPM	Watts	RPM	Watts
1750	644	137	740	235	796	302	833	343	873	373	996	558	1065	664
2000	675	165	768	260	821	330	861	386	960	507	1026	629	1094	753
2250	711	195	803	290	856	375	901	497	991	564	1058	703	1128	840
2500	764	241	852	335	904	439	951	568	1025	641	1097	789	1170	934
2750	847	316	901	399	946	543	1004	674	1074	746	1146	895	1220	1041
3000	944	426	980	511	1021	671	1074	803	1136	874	1205	1021	1276	1167
3250	1022	544	1057	640	1099	810	1149	942	1207	1012	1272	1156	1338	1304
3500	1092	666	1131	770	1174	948	1225	1081	1281	1151	1342	1297	1402	1451
3750	1161	780	1202	892	1248	1079	1298	1217	1353	1291	1409	1445	1463	1609
4000	1230	888	1273	1010	1319	1212	1369	1362	1421	1441	1471	1608	1518	1784
4250	1299	1006	1342	1140	1388	1362	1436	1526	1483	1612	1528	1790	1571	1975
4500	1366	1142	1409	1289	1454	1532	1498	1708	1542	1798	1583	1984	1623	2172
4750	1432	1295	1474	1457	1516	1719	1558	1903	1598	1997	1637	2187	1674	2377
5000	1496	1471	1537	1645	1577	1921	1616	2110	1654	2205	1690	2396	1726	2586
5250	1560	1667	1598	1849	1636	2132	1673	2324	1709	2419	1744	2609	1779	2796
5500	1623	1878	1659	2064	1695	2349	1731	2539	1765	2634	---	---	---	---
5750	1686	2097	1720	2284	1755	2567	---	---	---	---	---	---	---	---
6000	1748	2316	1781	2502	---	---	---	---	---	---	---	---	---	---

Total Air Volume cfm	Total Static Pressure - in. w.g.											
	1.6		1.8		2.0		2.2		2.4		2.6	
	RPM	Watts	RPM	Watts	RPM	Watts	RPM	Watts	RPM	Watts	RPM	Watts
1750	1134	775	1203	896	1275	1025	1356	1149	1422	1287	1470	1439
2000	1162	878	1231	1007	1302	1139	1379	1268	1440	1411	1486	1570
2250	1198	975	1268	1111	1338	1250	1409	1388	1464	1542	1507	1711
2500	1243	1075	1313	1217	1380	1365	1442	1517	1491	1685	1533	1860
2750	1293	1186	1361	1336	1423	1494	1477	1661	1520	1839	1561	2016
3000	1346	1317	1410	1474	1466	1642	1514	1818	1554	2000	1594	2180
3250	1402	1460	1460	1627	1511	1803	1553	1986	1591	2172	1631	2352
3500	1459	1616	1509	1793	1555	1976	1594	2165	1631	2352	1671	2531
3750	1512	1785	1557	1970	1599	2159	1636	2350	1673	2536	1713	2714
4000	1562	1969	1604	2157	1643	2347	1680	2538	1717	2722	1756	2896
4250	1611	2163	1650	2352	1688	2541	1724	2729	1762	2908	---	---
4500	1661	2362	1698	2552	1734	2739	1770	2922	---	---	---	---
4750	1710	2567	1746	2754	---	---	---	---	---	---	---	---
5000	1761	2774	---	---	---	---	---	---	---	---	---	---

BLOWER DATA

FACTORY INSTALLED OPTIONS/FIELD INSTALLED ACCESSORY AIR RESISTANCE - in. w.g.

Air Volume cfm	Wet Indoor Coil		Electric Heat	Economizer	Humiditrol Reheat Coil	Filters			Return Air Adaptor Plate
	092, 102	120, 150				MERV 8	MERV 13	MERV 16	
2000	0.05	0.05	0.03	0.06	0.02	0.01	0.03	0.08	0.00
2250	0.06	0.06	0.04	0.08	0.02	0.01	0.04	0.09	0.00
2500	0.07	0.07	0.04	0.11	0.03	0.01	0.05	0.10	0.00
2750	0.08	0.08	0.05	0.12	0.03	0.02	0.05	0.11	0.00
3000	0.10	0.09	0.06	0.13	0.03	0.02	0.06	0.12	0.02
3250	0.11	0.10	0.06	0.15	0.04	0.02	0.06	0.13	0.02
3500	0.12	0.11	0.09	0.15	0.04	0.03	0.07	0.15	0.04
3750	0.14	0.13	0.09	0.15	0.05	0.03	0.08	0.16	0.07
4000	0.15	0.14	0.09	0.19	0.05	0.04	0.08	0.17	0.09
4250	0.17	0.15	0.13	0.19	0.06	0.04	0.09	0.19	0.11
4500	0.19	0.17	0.14	0.22	0.07	0.04	0.09	0.20	0.12
4750	0.20	0.18	0.17	0.25	0.07	0.05	0.10	0.21	0.16
5000	0.22	0.20	0.20	0.29	0.08	0.06	0.10	0.23	0.18
5250	0.24	0.22	0.22	0.32	0.08	0.06	0.11	0.24	0.19
5500	0.25	0.23	0.25	0.34	0.09	0.07	0.12	0.25	0.22
5750	0.27	0.25	0.31	0.45	0.10	0.07	0.12	0.27	0.25
6000	0.29	0.27	0.33	0.52	0.10	0.08	0.13	0.28	0.27

MINIMUM AIR VOLUME REQUIRED FOR USE WITH OPTIONAL ELECTRIC HEAT

Electric Heat kW	Minimum cfm
7.5	1750
15	2250
22.5	2250
30	2750
45	2750
60	3500

POWER EXHAUST FAN PERFORMANCE

Return Air System Static Pressure in. w.g.	Air Volume Exhausted cfm
0	3175
0.05	2955
0.10	2685
0.15	2410
0.20	2165
0.25	1920
0.30	1420
0.35	1200

BLOWER DATA

CEILING DIFFUSERS AIR RESISTANCE - in. w.g.

Unit Size	RTD11 Step-Down Diffuser			FD11 Flush Diffuser	
	Air Volume cfm	2 Ends Open	1 Side, 2 Ends Open		All Ends & Sides Open
092 Models	2400	0.21	0.18	0.15	0.14
	2600	0.24	0.21	0.18	0.17
	2800	0.27	0.24	0.21	0.20
	3000	0.32	0.29	0.25	0.25
	3200	0.41	0.37	0.32	0.31
	3400	0.50	0.45	0.39	0.37
	3600	0.61	0.54	0.48	0.44
	3800	0.73	0.63	0.57	0.51
102 & 120 Models	3600	0.36	0.28	0.23	0.15
	3800	0.40	0.32	0.26	0.18
	4000	0.44	0.36	0.29	0.21
	4200	0.49	0.40	0.33	0.24
	4400	0.54	0.44	0.37	0.27
	4600	0.60	0.49	0.42	0.31
	4800	0.65	0.53	0.46	0.35
	5000	0.69	0.58	0.50	0.39
150 Models	5200	0.75	0.62	0.54	0.43
	4200	0.22	0.19	0.16	0.10
	4400	0.28	0.24	0.20	0.12
	4600	0.34	0.29	0.24	0.15
	4800	0.40	0.34	0.29	0.19
	5000	0.46	0.39	0.34	0.23
	5200	0.52	0.44	0.39	0.27
	5400	0.58	0.49	0.43	0.31
5600	0.64	0.54	0.47	0.35	
5800	0.70	0.59	0.51	0.39	

CEILING DIFFUSER AIR THROW DATA

Model No.	Air Volume cfm	¹ Effective Throw Range	
		RTD11 Step-Down ft.	FD11 Flush ft.
092 Models	2600	24 - 29	19 - 24
	2800	25 - 30	20 - 28
	3000	27 - 33	21 - 29
	3200	28 - 35	22 - 29
	3400	30 - 37	22 - 30
102, 120 Models	3600	25 - 33	22 - 29
	3800	27 - 35	22 - 30
	4000	29 - 37	24 - 33
	4200	32 - 40	26 - 35
	4400	34 - 42	28 - 37
150 Models	5600	39 - 49	28 - 37
	5800	42 - 51	29 - 38
	6000	44 - 54	40 - 50
	6200	45 - 55	42 - 51
	6400	46 - 55	43 - 52
6600	47 - 56	45 - 56	

¹ Throw is the horizontal or vertical distance an air stream travels on leaving the outlet or diffuser before the maximum velocity is reduced to 50 ft. per minute. Four sides open.

ELECTRICAL/ELECTRIC HEAT DATA

7.5 TON

Model No.		LCT092H4E / LCT092H4P		
¹ Voltage - 60Hz		208/230V-3ph	460V-3ph	575V-3ph
Compressor 1 (Non-Inverter)	Rated Load Amps	11.9	6.8	4.8
	Locked Rotor Amps	112	61.8	39
Compressor 2 (Non-Inverter)	Rated Load Amps	12.2	6.4	5.1
	Locked Rotor Amps	120.4	50	41
Outdoor Fan Motors (2)	Full Load Amps (2 Non-ECM)	2.4	1.3	1
	Total	4.8	2.6	2
Power Exhaust (1) 0.33 HP	Full Load Amps	2.4	1.3	1
Service Outlet 115V GFI (amps)		15	15	20
Indoor Blower Motor	HP	3.75	3.75	3.75
	Full Load Amps	8	4.2	3.6
² Maximum Overcurrent Protection (MOCP)	Unit Only	50	25	20
	With (1) 0.33 HP Power Exhaust	50	25	20
³ Minimum Circuit Ampacity (MCA)	Unit Only	40	22	17
	With (1) 0.33 HP Power Exhaust	43	24	18

ELECTRIC HEAT DATA

Electric Heat Voltage			208V	240V	480V	600V
² Maximum Overcurrent Protection (MOCP)	Unit+ Electric Heat	7.5 kW	50	50	25	20
		15 kW	⁴ 50	60	30	25
		22.5 kW	⁴ 70	80	40	35
		30 kW	⁴ 90	110	60	45
		45 kW	150	150	80	60
³ Minimum Circuit Ampacity (MCA)	Unit+ Electric Heat	7.5 kW	40	40	22	17
		15 kW	50	56	28	23
		22.5 kW	69	78	40	32
		30 kW	89	101	51	41
		45 kW	128	146	73	59
² Maximum Overcurrent Protection (MOCP)	Unit+ Electric Heat and (1) 0.33 HP Power Exhaust	7.5 kW	50	50	25	20
		15 kW	60	60	30	25
		22.5 kW	⁴ 80	90	45	35
		30 kW	⁴ 100	110	60	45
		45 kW	150	150	80	60
³ Minimum Circuit Ampacity (MCA)	Unit+ Electric Heat and (1) 0.33 HP Power Exhaust	7.5 kW	43	43	24	18
		15 kW	53	59	30	24
		22.5 kW	72	81	41	33
		30 kW	92	104	52	42
		45 kW	131	149	75	60

ELECTRICAL ACCESSORIES

Disconnect	7.5 kW	15 kW	22.5 kW	30 kW	45 kW
	54W56	54W56	54W56	54W56	54W56
	54W56	54W56	54W56	54W56	54W56
	54W56	54W56	54W56	54W56	54W56
	54W57	54W57	54W56	54W56	54W56
	54W57	54W57	54W56	54W56	54W56

NOTE - All units have a minimum Short Circuit Current Rating (SCCR) of 5000 amps.

¹ Extremes of operating range are plus and minus 10% of line voltage.

² HACR type breaker or fuse.

³ Refer to National or Canadian Electrical Code manual to determine wire, fuse and disconnect size requirements.

⁴ Factory installed circuit breaker not available.

ELECTRICAL/ELECTRIC HEAT DATA

8.5 TON

Model No.		LCT102H4E/ LCT102H4P		
¹ Voltage - 60Hz		208/230V-3ph	460V-3ph	575V-3ph
Compressor 1 (Non-Inverter)	Rated Load Amps	11.9	6.8	4.8
	Locked Rotor Amps	112	61.8	39
Compressor 2 (Non-Inverter)	Rated Load Amps	12.8	6	5.8
	Locked Rotor Amps	120.4	49.4	41
Outdoor Fan Motors (2)	Full Load Amps (2 Non-ECM)	2.4	1.3	1
	Total	4.8	2.6	2
Power Exhaust (1) 0.33 HP	Full Load Amps	2.4	1.3	1
Service Outlet 115V GFI (amps)		15	15	20
Indoor Blower Motor	HP	3.75	3.75	3.75
	Full Load Amps	8	4.2	3.6
² Maximum Overcurrent Protection (MOCP)	Unit Only	50	25	20
	With (1) 0.33 HP Power Exhaust	50	25	20
³ Minimum Circuit Ampacity (MCA)	Unit Only	41	22	18
	With (1) 0.33 HP Power Exhaust	44	23	19

ELECTRIC HEAT DATA

Electric Heat Voltage				208V	240V	480V	600V
² Maximum Overcurrent Protection (MOCP)	Unit+ Electric Heat	7.5 kW		50	50	25	20
		15 kW		⁴ 50	60	30	25
		22.5 kW		⁴ 70	80	40	35
		30 kW		⁴ 90	110	60	45
		45 kW		150	150	80	60
³ Minimum Circuit Ampacity (MCA)	Unit+ Electric Heat	7.5 kW		41	41	22	18
		15 kW		50	56	28	23
		22.5 kW		69	78	40	32
		30 kW		89	101	51	41
		45 kW		128	146	73	59
² Maximum Overcurrent Protection (MOCP)	Unit+ Electric Heat and (1) 0.33 HP Power Exhaust	7.5 kW		50	50	25	20
		15 kW		60	60	30	25
		22.5 kW		⁴ 80	90	45	35
		30 kW		⁴ 100	110	60	45
		45 kW		150	150	80	60
³ Minimum Circuit Ampacity (MCA)	Unit+ Electric Heat and (1) 0.33 HP Power Exhaust	7.5 kW		44	44	23	19
		15 kW		53	59	30	24
		22.5 kW		72	81	41	33
		30 kW		92	104	52	42
		45 kW		131	149	75	60

ELECTRICAL ACCESSORIES

Disconnect	7.5 kW	54W56	54W56	54W56	54W56
	15 kW	54W56	54W56	54W56	54W56
	22.5 kW	54W56	54W56	54W56	54W56
	30 kW	54W57	54W57	54W56	54W56
	45 kW	54W57	54W57	54W56	54W56

Disconnects - **54W56** - 80A
54W57 - 150A

NOTE - All units have a minimum Short Circuit Current Rating (SCCR) of 5000 amps.

¹ Extremes of operating range are plus and minus 10% of line voltage.

² HACR type breaker or fuse.

³ Refer to National or Canadian Electrical Code manual to determine wire, fuse and disconnect size requirements.

⁴ Factory installed circuit breaker not available.

ELECTRICAL/ELECTRIC HEAT DATA

10 TON

Model No.		LCT120H4E/ LCT120H4P		
¹ Voltage - 60Hz		208/230V-3ph	460V-3ph	575V-3ph
Compressor 1 (Non-Inverter)	Rated Load Amps	13.8	6.9	5.8
	Locked Rotor Amps	150	58	47.8
Compressor 2 (Non-Inverter)	Rated Load Amps	16	7.1	6.4
	Locked Rotor Amps	156.4	69	47.8
Outdoor Fan Motors (2)	Full Load Amps (2 Non-ECM)	3	1.5	1.2
	Total	6	3	2.4
Power Exhaust (1) 0.33 HP	Full Load Amps	2.4	1.3	1
Service Outlet 115V GFI (amps)		15	15	20
Indoor Blower Motor	HP	3.75	3.75	3.75
	Full Load Amps	8	4.2	3.6
² Maximum Overcurrent Protection (MOCP)	Unit Only	60	30	25
	With (1) 0.33 HP Power Exhaust	60	30	25
³ Minimum Circuit Ampacity (MCA)	Unit Only	48	23	20
	With (1) 0.33 HP Power Exhaust	51	25	21

ELECTRIC HEAT DATA

Electric Heat Voltage			208V	240V	480V	600V
² Maximum Overcurrent Protection (MOCP)	Unit+ Electric Heat	15 kW	60	60	30	25
		22.5 kW	⁴ 70	80	40	35
		30 kW	⁴ 90	110	60	45
		45 kW	150	150	80	60
		60 kW	⁴ 150	175	80	70
³ Minimum Circuit Ampacity (MCA)	Unit+ Electric Heat	15 kW	50	56	28	23
		22.5 kW	69	78	40	32
		30 kW	89	101	51	41
		45 kW	128	146	73	59
		60 kW	136	155	78	63
² Maximum Overcurrent Protection (MOCP)	Unit+ Electric Heat and (1) 0.33 HP Power Exhaust	15 kW	60	60	30	25
		22.5 kW	⁴ 80	90	45	35
		30 kW	⁴ 100	110	60	45
		45 kW	150	150	80	60
		60 kW	⁴ 150	175	80	70
³ Minimum Circuit Ampacity (MCA)	Unit+ Electric Heat and (1) 0.33 HP Power Exhaust	15 kW	53	59	30	24
		22.5 kW	72	81	41	33
		30 kW	92	104	52	42
		45 kW	131	149	75	60
		60 kW	139	158	80	64

ELECTRICAL ACCESSORIES

Disconnect	15 kW	54W56	54W56	54W56	54W56
	22.5 kW	54W56	54W56	54W56	54W56
	30 kW	54W57	54W57	54W56	54W56
	45 kW	54W57	54W57	54W56	54W56
	60 kW	N/A	N/A	54W57	54W56

Disconnects - **54W56** - 80A
54W57 - 150A

NOTE - All units have a minimum Short Circuit Current Rating (SCCR) of 5000 amps.

¹ Extremes of operating range are plus and minus 10% of line voltage.

² HACR type breaker or fuse.

³ Refer to National or Canadian Electrical Code manual to determine wire, fuse and disconnect size requirements.

⁴ Factory installed circuit breaker not available.

ELECTRICAL/ELECTRIC HEAT DATA

12.5 TON

Model No.		LCT150H4E/ LCT150H4P		
¹ Voltage - 60Hz		208/230V-3ph	460V-3ph	575V-3ph
Compressor 1 (Non-Inverter)	Rated Load Amps	19.2	9.1	6.2
	Locked Rotor Amps	162.3	70.8	58.2
Compressor 2 (Non-Inverter)	Rated Load Amps	22.4	9.1	7.2
	Locked Rotor Amps	166.2	74.6	54
Outdoor Fan Motors (2)	Full Load Amps (2 Non-ECM)	3	1.5	1.2
	Total	6	3	2.4
Power Exhaust (1) 0.33 HP	Full Load Amps	2.4	1.3	1
Service Outlet 115V GFI (amps)		15	15	20
Indoor Blower Motor	Horsepower	3.75	3.75	3.75
	Full Load Amps	8	4.2	3.6
² Maximum Overcurrent Protection (MOCP)	Unit Only	80	35	25
	With (1) 0.33 HP Power Exhaust	80	35	25
³ Minimum Circuit Ampacity (MCA)	Unit Only	62	28	22
	With (1) 0.33 HP Power Exhaust	64	29	23

ELECTRIC HEAT DATA

Electric Heat Voltage			208V	240V	480V	600V
² Maximum Overcurrent Protection (MOCP)	Unit+	15 kW	80	80	35	25
	Electric Heat	22.5 kW	80	80	40	35
		30 kW	⁴ 90	110	60	45
		45 kW	150	150	80	60
		60 kW	⁴ 150	175	80	70
³ Minimum Circuit Ampacity (MCA)	Unit+	15 kW	62	62	28	23
	Electric Heat	22.5 kW	69	78	40	32
		30 kW	89	101	51	41
		45 kW	128	146	73	59
		60 kW	136	155	78	63
² Maximum Overcurrent Protection (MOCP)	Unit+	15 kW	80	80	35	25
	Electric Heat and (1) 0.33 HP Power Exhaust	22.5 kW	⁴ 80	90	45	35
		30 kW	⁴ 100	110	60	45
		45 kW	150	150	80	60
		60 kW	⁴ 150	175	80	70
³ Minimum Circuit Ampacity (MCA)	Unit+	15 kW	64	64	30	24
	Electric Heat and (1) 0.33 HP Power Exhaust	22.5 kW	72	81	41	33
		30 kW	92	104	52	42
		45 kW	131	149	75	60
		60 kW	139	158	80	64

ELECTRICAL ACCESSORIES

Disconnect	15 kW	54W56	54W56	54W56	54W56
	22.5 kW	54W56	54W56	54W56	54W56
	30 kW	54W57	54W57	54W56	54W56
	45 kW	54W57	54W57	54W56	54W56
	60 kW	N/A	N/A	54W57	54W56

Disconnects - **54W56** - 80A
54W57 - 150A

NOTE - All units have a minimum Short Circuit Current Rating (SCCR) of 5000 amps.

¹ Extremes of operating range are plus and minus 10% of line voltage.

² HACR type breaker or fuse.

³ Refer to National or Canadian Electrical Code manual to determine wire, fuse and disconnect size requirements.

⁴ Factory installed circuit breaker not available.

ELECTRIC HEAT CAPACITIES

Volts Input	7.5 kW			15 kW			22.5 kW			30 kW			45 kW			60 kW		
	kW Input	Btuh Output	No. of Stages	kW Input	Btuh Output	No. of Stages	kW Input	Btuh Output	No. of Stages	kW Input	Btuh Output	No. of Stages	kW Input	Btuh Output	No. of Stages	kW Input	Btuh Output	No. of Stages
208	5.6	19,100	1	11.3	38,600	1	16.9	57,700	2	22.5	76,800	2	33.8	115,300	2	45.0	153,600	2
220	6.3	21,500	1	12.6	43,000	1	18.9	64,500	2	25.2	86,000	2	37.8	129,000	2	50.4	172,000	2
230	6.9	23,600	1	13.8	47,100	1	20.7	70,700	2	27.5	93,900	2	41.3	141,000	2	55.1	188,000	2
240	7.5	25,600	1	15.0	51,200	1	22.5	76,800	2	30.0	102,400	2	45.0	153,600	2	60.0	204,800	2
440	6.9	21,500	1	12.6	43,000	1	18.9	64,500	2	25.2	86,000	2	37.8	129,000	2	50.4	172,000	2
460	6.9	23,600	1	13.8	47,100	1	20.7	70,700	2	27.5	93,900	2	41.3	141,000	2	55.1	188,000	2
480	7.5	25,600	1	15.0	51,200	1	22.5	76,800	2	30.0	102,400	2	45.0	153,600	2	60.0	204,800	2
550	6.3	21,500	1	12.6	43,000	1	18.9	64,500	2	25.2	86,000	2	37.8	129,000	2	50.4	172,000	2
575	6.9	23,600	1	13.8	47,100	1	20.7	70,700	2	27.5	93,900	2	41.3	141,000	2	55.1	188,000	2
600	7.5	25,600	1	15.0	51,200	1	22.5	76,800	2	30.0	102,400	2	45.0	153,600	2	60.0	204,800	2

Minimum R454B Space and CFM Requirements

Minimum Airflow ¹		
Unit	Q _{min} (CFM)	Q _{min} (m ³ /h)
LCT092	165	281
LCT102	165	281
LCT120	155	264
LCT150	165	281
LCT092 W/ Humidrol	172	292
LCT102 W/ Humidrol	172	292
LCT120 W/ Humidrol	165	281
LCT150 W/ Humidrol	165	281

¹ **NOTE** - The minimum airflow is the lowest CFM allowed during venting operation (leak mitigation).

Minimum Room Area of Conditioned Space ²		
Unit	TA _{min} (ft ²)	TA _{min} (m ²)
LCT092	92	8.5
LCT102	92	8.5
LCT120	87	8.0
LCT150	92	8.5
LCT092 W/ Humidrol	96	8.8
LCT102 W/ Humidrol	96	8.8
LCT120 W/ Humidrol	92	8.5
LCT150 W/ Humidrol	92	8.5

² **NOTE** - The minimum room area of conditioned space is the smallest area the unit can service.

Refrigerant Charge R-454B		
Unit	M _c (lbs)	M _c (kg)
LCT092 STG 1	6.25	2.83
LCT092 STG 2	5.88	2.67
LCT102 STG 1	6.25	2.83
LCT102 STG 2	5.88	2.67
LCT120 STG 1	5.88	2.67
LCT120 STG 2	5.88	2.67
LCT150 STG 1	5.75	2.61
LCT150 STG 2	6.25	2.83
LCT092 W/ Humidrol STG 1	6.5	2.95
LCT092 W/ Humidrol STG 2	5.88	2.67
LCT102 W/ Humidrol STG 1	6.5	2.95
LCT102 W/ Humidrol STG 2	5.88	2.67
LCT120 W/ Humidrol STG 1	6.25	2.83
LCT120 W/ Humidrol STG 2	5.88	2.67
LCT150 W/ Humidrol STG 1	6.13	2.78
LCT150 W/ Humidrol STG 2	6.25	2.83

Altitude Adjustment Factor ³									
Halt	0	200	400	600	800	1000	1200	1400	1600
AF	1	1	1	1	1.02	1.05	1.04	1.1	1.12
Halt	1600	1800	2000	2200	2400	2600	2800	3000	3200
AF	1.12	1.15	1.18	1.21	1.25	1.28	1.32	1.36	1.4

³ **NOTE** - Use the Altitude Adjustment Factor to adjust the values in the tables above to different altitudes. Find the relevant altitude above sea level in the two "Halt" rows and then multiply the value needed from the tables above by the altitude factor number. Example: For the minimum airflow in CFM for an LCT092 at 1000 ft. above sea level, multiply 165 by 1.05 to get 173.25 CFM as the new Q_{min}.

Parts Arrangement

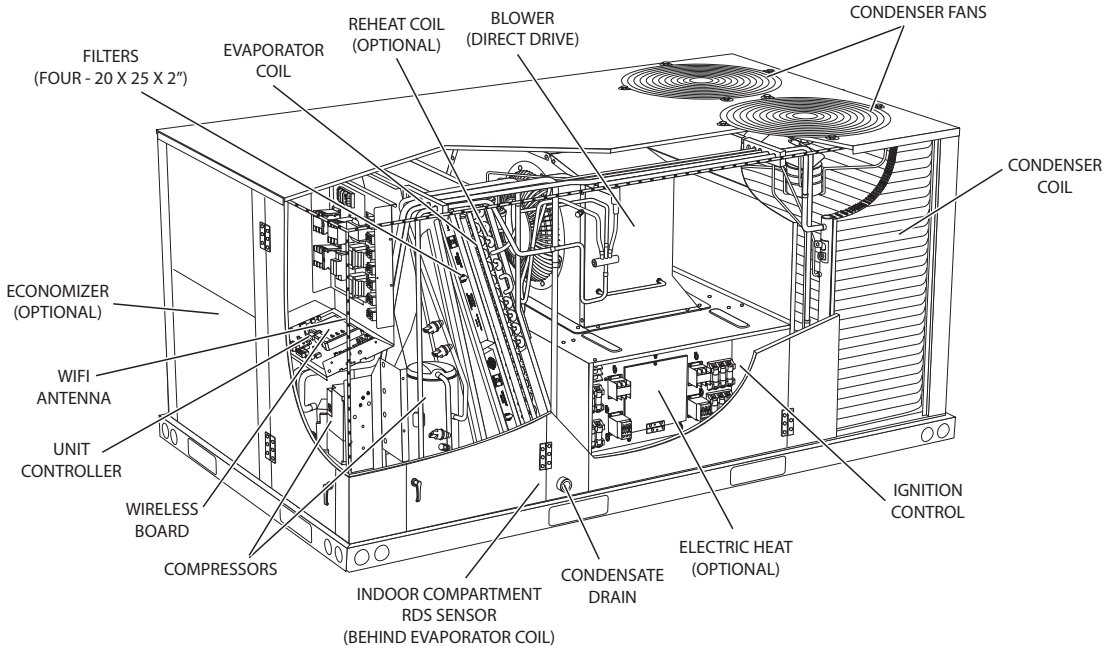

FIGURE 1

CONTROL BOX PARTS ARRANGEMENT

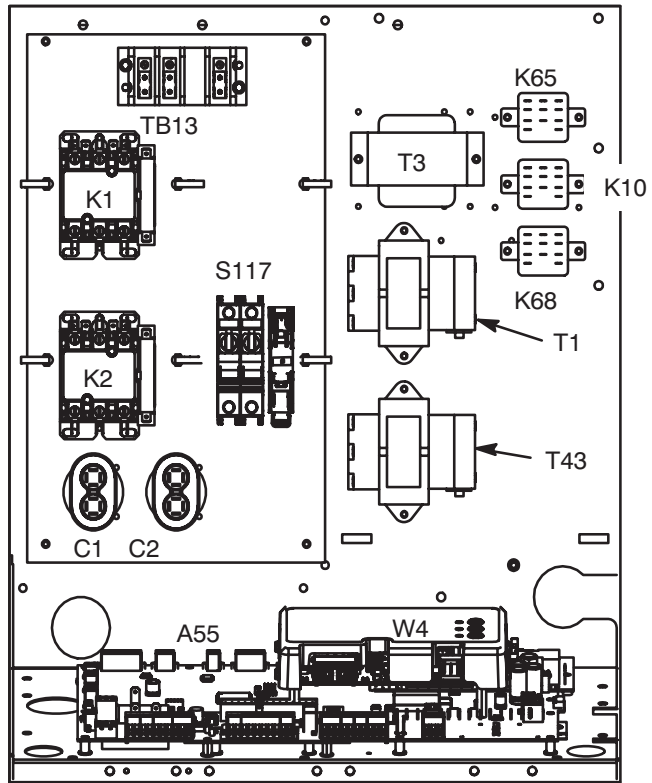



FIGURE 2

I-UNIT COMPONENTS

⚠ WARNING	
	Electric shock hazard. Can cause injury or death. Before attempting to perform any service or maintenance, turn the electrical power to unit OFF at disconnect switch(es). Unit may have multiple power supplies.

ELECTROSTATIC DISCHARGE (ESD) Precautions and Procedures	
⚠ CAUTION	
	Electrostatic discharge can affect electronic components. Take precautions to neutralize electrostatic charge by touching your hand and tools to metal prior to handling the control.

All 7.5 through 12.5 ton (38.1 through 70.3 kW) units are configured to order units (CTO). The LCT unit components are shown in figure 1. All units come standard with hinged unit panels. All L1, L2 and L3 wiring is color coded; L1 is red, L2 is yellow and L3 is blue.

A-Control Box Components

LCT control box components are shown in FIGURE 2. The control box is located in the upper portion of the compressor compartment.

1-Disconnect Switch S48 (Optional)

All units may be equipped with an optional disconnect switch S48. Other factory or field installed optional circuit breakers may be used, such as CB10. S48 and CB10 are toggle switches, which can be used by the service technician to disconnect power to the unit.

2-Control Transformer T43 (Re-Heat Units)

T43 is a single line voltage to 24VAC and ties into T1. See unit diagram. T43 is mounted in the control box. The transformer supplies power to control circuits (through T1). The transformer is rated at 70VA and is protected by a 3.5 amp circuit breaker (CB31). The 208/230 (Y) voltage transformers use primary voltage taps as shown in figure 3, while 460 (G) and 575 (J) voltage transformers use a single primary voltage tap.

3-Control Transformer T1

All use a single line voltage to 24VAC transformer mounted in the control box. Transformer supplies power to control circuits in the unit. The transformer is rated at 92VA and is protected by a 6 amp circuit breaker (CB8). The 208/230 (Y) voltage transformers use primary voltage taps as shown in FIGURE 3, while 460 (G) and 575 (J) voltage transformers use a single primary voltage tap.

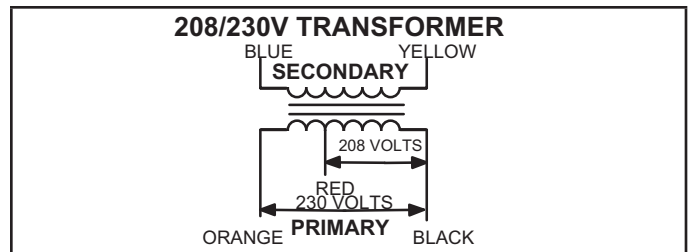

FIGURE 3

4-Outdoor Fan Relay K10, K68

Outdoor fan relays K10 and K68 are DPDT relays with a 24VAC coil. In standard and high efficiency units, K10 and K68 energize condenser fans B4 and B5.

5-Outdoor Fan Capacitors C1, C2

Fan capacitors C1 and C2 are used to assist in the start up of condenser fans B4 and B5. Capacitor size varies with unit tonnage and voltage.

LCT092-102 all voltages - 370V/10 MFD

LCT120-150 J volt - 370/10 MFD

LCT120-150 G volt - 370V/12.5 MFD

LCT120-150 Y volt - 370V/15 MFD

6-Compressor Contactor K1, K2

All compressor contactors are three-pole, double-break contactors with 24VAC coils. K1 and K2 (both energized by A55) energize compressors B1 and B2.

7-Unit Controller A55

The Unit Controller provides all unit control functions, unit status information, unit diagnostics, programmable parameters and USB verification and profile sharing. Refer to the Unit Controller guide provided with the unit. Thermostat wires are connected to J297 on the Unit Controller.

8-Power Exhaust Relay K65 (PED units)

Power exhaust relay K65 is a N.O. DPDT relay with a 24VAC coil. K65 is used in all LCT units equipped with the optional power exhaust dampers. K65 is energized by the economizer control panel (A56), after the economizer dampers reach 50% open (adjustable in CORE). When K65 closes, the exhaust fan B10 is energized.

9-Terminal Block TB13

TB13 terminal block distributes line voltage power to the line voltage items in the unit.

10-Wireless Antenna

Wireless antenna is located above the return air compartment of the unit. FIGURE 4 shows location and FIGURE 5 shows cable routing. Please follow the CORE Controller setup guide included in the unit.

Antenna Location

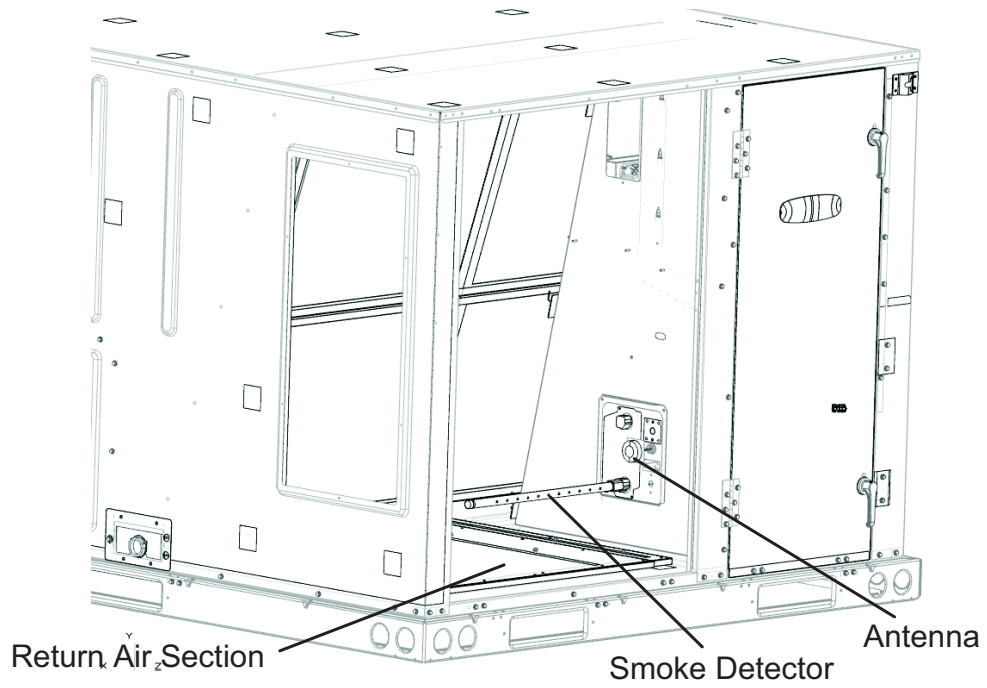

FIGURE 4

Cable Routing

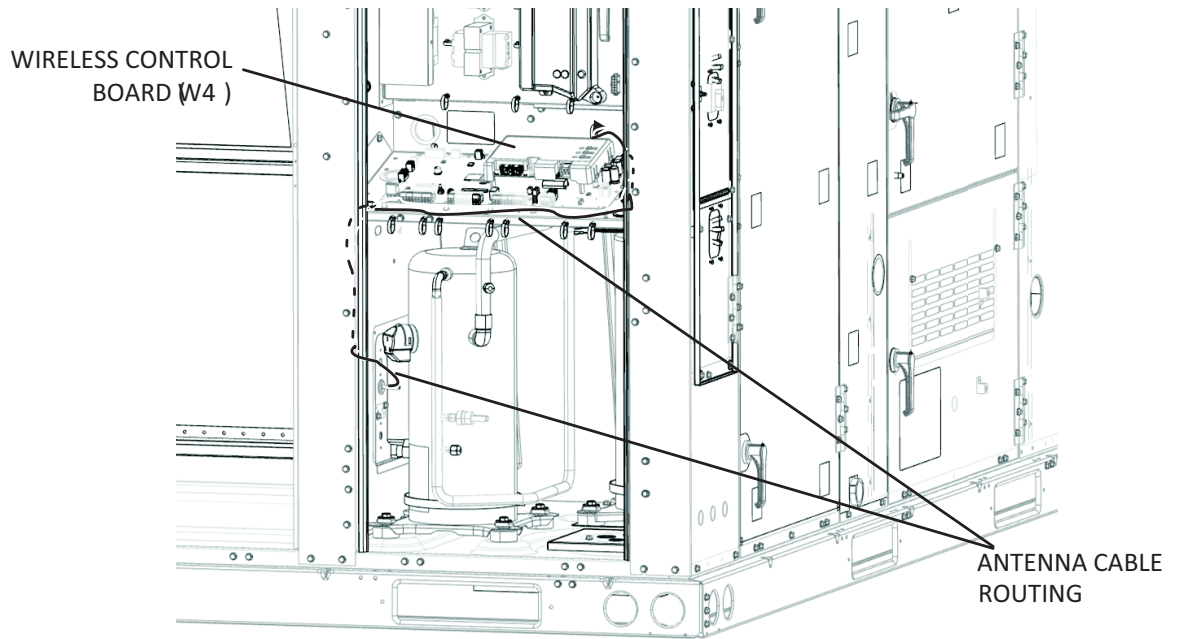

FIGURE 5

Temperature Sensors

The return air (RT16) and discharge air (RT6) duct probes and the outdoor air (RT17) are all two wire thermistors. The resistance vs. temperature table is shown below:

Relative Humidity Sensor - Optional

The indoor relative humidity sensor (A91) is an analog sensor with a 0-10VDC output over a relative humidity range of 0-100% relative humidity. The sensor is powered with 24VAC.

Enthalpy Sensor - Optional

The optional enthalpy sensors (A7 and A63) used with the economizer have an output of 4-20mA.

The sensor is powered with 18VAC provided by M3 unit control.

Economizer Differential Pressure Sensor - Optional

Rooftop units installed with Smart Airflow™ will have a Pressure Transducer (PT5) present in the economizer. PT5 requires 5VDC power supply (P266-5 and {P266-6) and gives 0.25 VDC to 4 VDC output (P266-4) corresponding to 0" water column and 2" water column respectively.

For all practical purposes the output should be less than 1.2" water column if not an error code is stored and service alarm output is turned on.

TABLE 1
Resistance vs. Temperature

Temp. °F (°C)	Resistance +/-2%	Temperature °F (°C)	Resistance +/-2%	Temp. °F (°C)	Resistance +/-2%
-40 (-40)	335,671	40 (4.4)	26,106	90 (32.2)	7,332
-20 (-28.9)	164,959	50 (10)	19,904	100 (37.8)	5,826
0 (-17.8)	85,323	60 (15.6)	15,313	120 (48.9)	3,756
20 (-6.7)	46,218	70 (21.1)	11,884	130 (54.4)	3,047
30 (-1.1)	34,566	80 (26.7)	9,298		

Room Sensors

Room sensor (A2) is a two-wire thermistor with 1k series resistor.

TABLE 2
Two-Wire Thermistor

Temp. °F (°C)	Resistance +/-2%	Temperature °F (°C)	Resistance +/-2%	Temp. °F (°C)	Resistance +/-2%
40 (4.4)	27,102	60 (15.6)	16,313	80 (26.7)	10,299
45 (7.2)	23,764	65 (18.3)	14,474	85 (29.4)	9,249
50 (10)	20,898	70 (21.1)	12,882	90 (32.2)	8,529
55 (12.8)	18,433	75 (23.9)	11,498		

Carbon Dioxide Sensor

The indoor carbon dioxide sensor (A63) is an analog sensor with a 0-10VDC output over a carbon dioxide range of 0-2000 ppm as shown in the following table. The sensor is powered with 24VAC.

TABLE 3
Carbon Dioxide Range

Carbon Dioxide PPM	DC Voltage	Carbon Dioxide PPM	DC Voltage	Carbon Dioxide PPM	DC Voltage	Carbon Dioxide PPM	DC Voltage
0	0	600	3	1200	6	1800	9
200	1	800	4	1400	7	2000	10
400	2	1000	5	1600	8		

VAV Supply Static Sensor

The supply duct differential static pressure sensor (A30) is an analog sensor with a 0-10VDC output over a range of 0-5"w.c as shown in the following table. The sensor is powered with 24VAC.

TABLE 4
Carbon Dioxide Range

Pressure "w.c.	DC Voltage	Pressure "w.c.	DC Voltage	Pressure "w.c.	DC Voltage	Pressure "w.c.	DC Voltage
0	0	1.5	3	3	6	4.5	9
0.5	1	2	4	3.5	7	5	10
1	2	2.5	5	4	8		

PLUMBING, COMPRESSOR AND REFRIGERANT CIRCUITS DETAIL

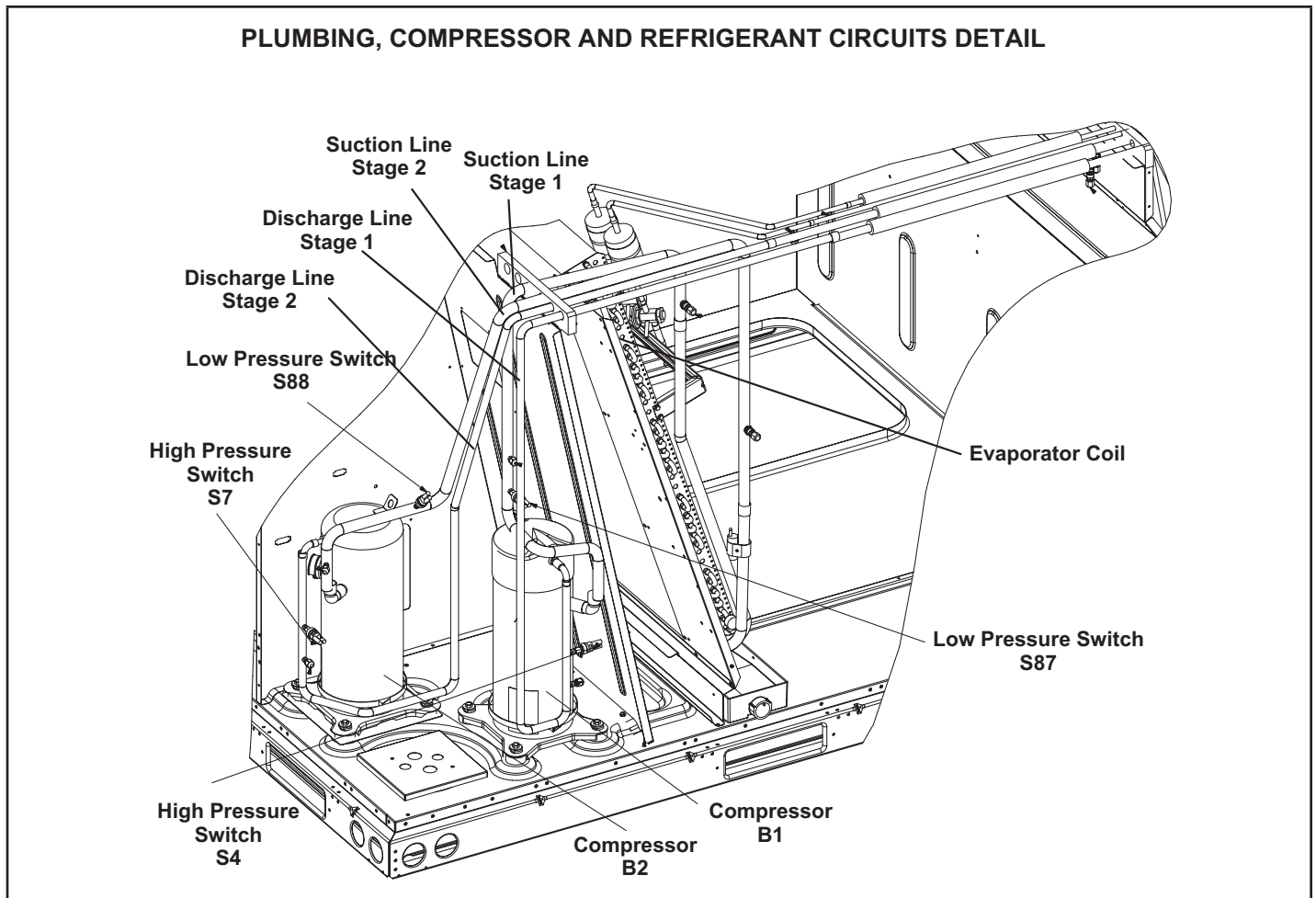

FIGURE 6

B-Cooling Components

High efficiency units use independent cooling circuits consisting of separate compressors, condenser coils and evaporator coils. See FIGURE 6. Units are equipped with ECM direct drive blowers which draw air across the evaporator during unit operation.

On all units the evaporators are slab type and are row split. Each evaporator uses a thermostatic expansion valve as the primary expansion device.

In all units, each compressor is protected by a crankcase heater, high pressure switch and low pressure switch. Additional protection is provided by thermistors for low ambient control and freezing prevention.

Cooling may be supplemented by a factory- or field-installed economizer.

1-Compressors B1, B2

Units are equipped with two scroll compressors and two independent cooling circuits. B1 is 2-stage compressor, with L34 to switching between part load and full load, B2 is single stage compressor. Compressor capacity may vary from stage to stage. In all cases, the capacity of each compressor is added to reach the total capacity of the unit. See "SPECIFICATIONS" and "ELECTRICAL DATA" (table of contents) or compressor nameplate for compressor specifications.

⚠ WARNING

Electrical shock hazard. Compressor must be grounded. Do not operate without protective cover over terminals. Disconnect power before removing protective cover. Discharge capacitors before servicing unit. Failure to follow these precautions could cause electrical shock resulting in injury or death.

Each compressor is energized by a corresponding compressor contactor.

NOTE-Refer to the wiring diagram section for specific unit operation. If Interlink compressor replacement is necessary, call 1-800-453-6669.

IMPORTANT

Some scroll compressors have an internal vacuum protector that will unload scrolls when suction pressure goes below 20 psig. A hissing sound will be heard when the compressor is running unloaded. Protector will reset when low pressure in system rises above 40 psig. DO NOT REPLACE COMPRESSOR.

2-Crankcase Heaters HR1, HR2

All LCT units use insertion type heaters. Heater HR1 is installed around compressor B1 and heater HR2 is installed around compressor B2. Crankcase heater wattage varies by compressor size.

3-High Pressure Switches S4, S7

The high pressure switch is an auto-reset SPST N.C. switch which opens on a pressure rise. All units are equipped with this switch. On fin/tube outdoor coils, the switch is located in the compressor discharge line. On aluminum outdoor coils, the switch is located on the liquid line in the blower section. Switches are wired in series with the compressor contactor coil.

On all units, S4 (first circuit) and S7 (second circuit) are wired in series with the respective compressor contactor coils. On ultra high efficiency units, only S4 is used. S4 is located on the common compressor discharge line and is wired to both compressor contactors via the A55 Unit Controller.

When discharge pressure rises to 640 ± 20 psig (4413 ± 138 kPa) (indicating a problem in the system) the switch opens and the respective compressor is de-energized (the economizer can continue to operate). When discharge pressure drops to 475 ± 20 psig (3275 ± 138 kPa) the pressure switch will close.

The M4 Unit Controller has a three-strike counter before locking out. This means the control allows three high pressure trips per one thermostat demand. The control can be reset by breaking and remaking the thermostat demand or manually resetting the control.

4-Filter Drier

LCT units have a filter drier located in the liquid line of each refrigerant circuit. The drier removes contaminants and moisture from the system.

5-Low Pressure Switches S87, S88

The low pressure switch is an auto-reset SPST N.O. switch (held N.C. by refrigerant pressure) which opens on a pressure drop. All units are equipped with this switch. The switch is located in the compressor suction line.

On standard and high efficiency units, S87 (compressor one) and S88 (compressor two) are wired to A55 Unit Controller. On ultra high efficiency units, S87 (only) is located on the common suction line and is wired to A55 Unit Controller.

A55 governs the low pressure switches by shunting the switches during start up until pressure is stabilized. After the shunt period, the control has a three-strike counter, during first thermostat demand, before the compressor is locked out. The control is reset by breaking and remaking the thermostat demand or manually resetting the control.

When suction pressure drops to 40 ± 5 psig (276 ± 34 kPa), (indicating low pressure), the switch opens and the compressor(s) is(are) de-energized. The switch automatically resets when pressure in the suction line rises to 90 ± 5 psig (620 ± 34 kPa) due to many causes such as refrigerant being added.

6-Condenser Fans B4 and B5

See SPECIFICATIONS tables at the front of this manual for specifications of condenser fans used in all units. All condenser fans have single-phase motors. The fan assembly may be removed for servicing and cleaning.

7-Temperature Sensors RT46, RT47, RT48 & RT49

Units are equipped with four factory-installed thermistors (RT46-RT49) located on different points on the refrigerant circuit.

The thermistors provide the Unit Controller with constant temperature readings of four specific locations on the refrigeration circuit. These temperatures are used as feedback in certain modes of unit operation.

Each thermistor must be specifically placed for proper unit operation and to initiate valid alarms. See FIGURE 7 and FIGURE 8 proper locations.

**THERMISTOR LOCATION - EVAPORATOR COIL
RT46, RT47**

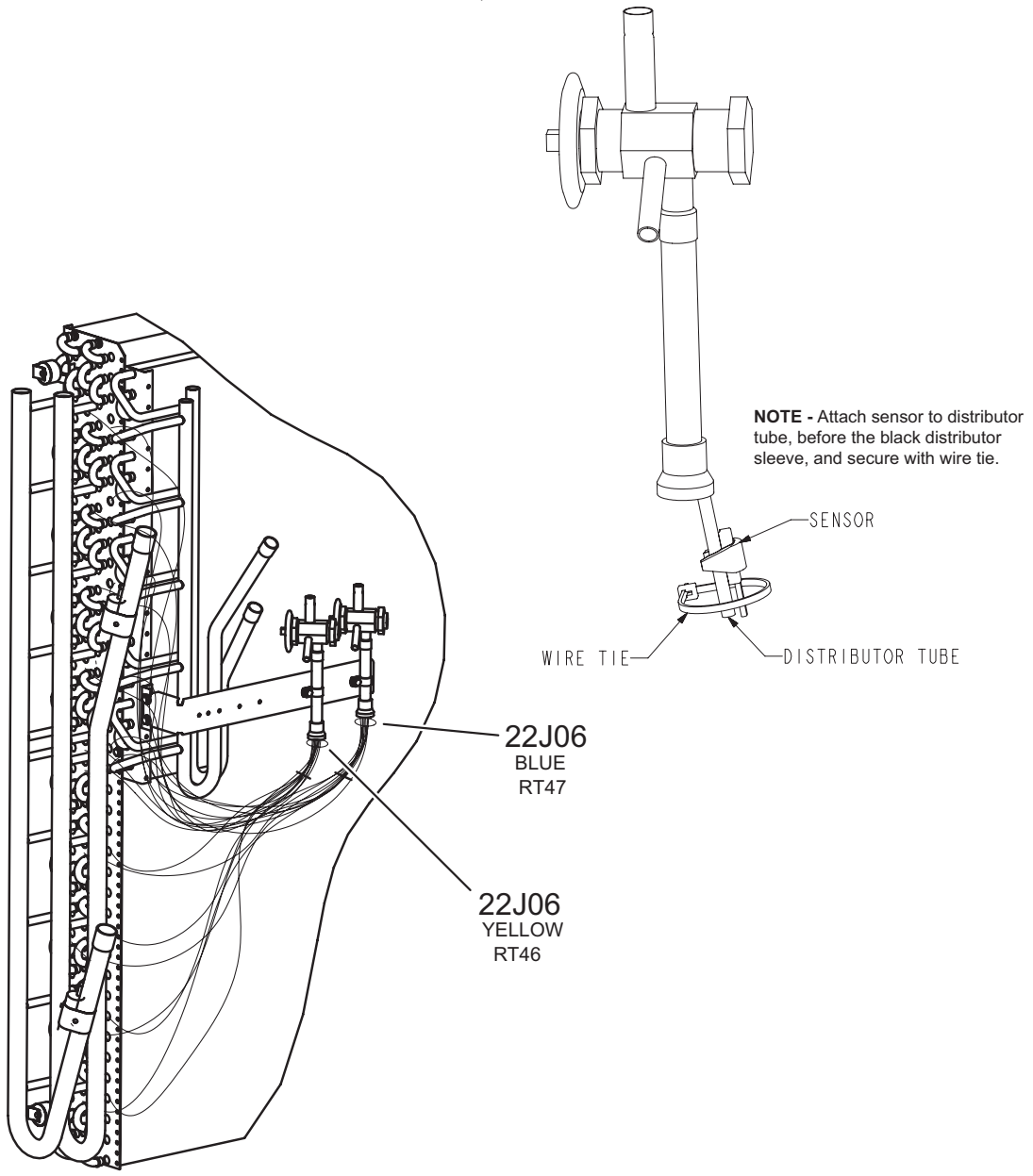
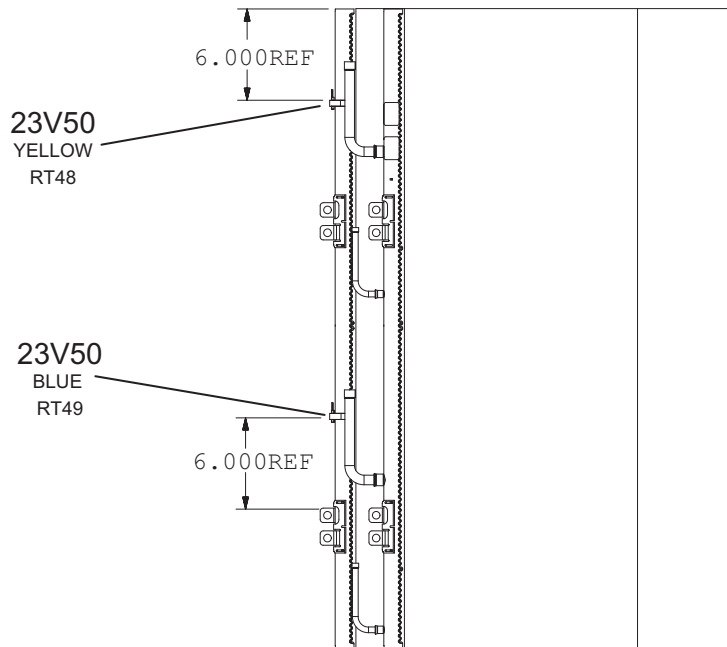
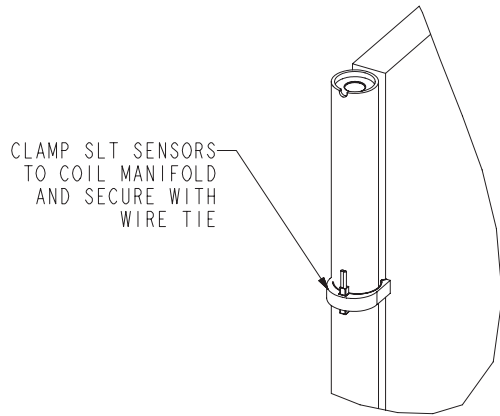

FIGURE 7

**THERMISTOR LOCATION - CONDENSER COIL
RT48, RT49**



DETAILS NOT TO SCALE

FIGURE 8

8-RDS Sensor RT58

Units are equipped with factory-installed RDS Sensors located on different points on the unit. The RDS sensors provide the Unit Controller with continuous readings for leaked refrigerant concentration levels and sensor health status (Good or Fault). These readings are used to modify unit operation to disperse the leaked refrigerant and to remove possible ignition sources. In addition, the Unit Controller uses these readings to initiate alarms to alert the operator of a refrigerant leak or faulty sensor(s).

Each sensor must be specifically placed for proper unit operation and to initiate valid alarms. To identify sensor locations see FIGURE 9.

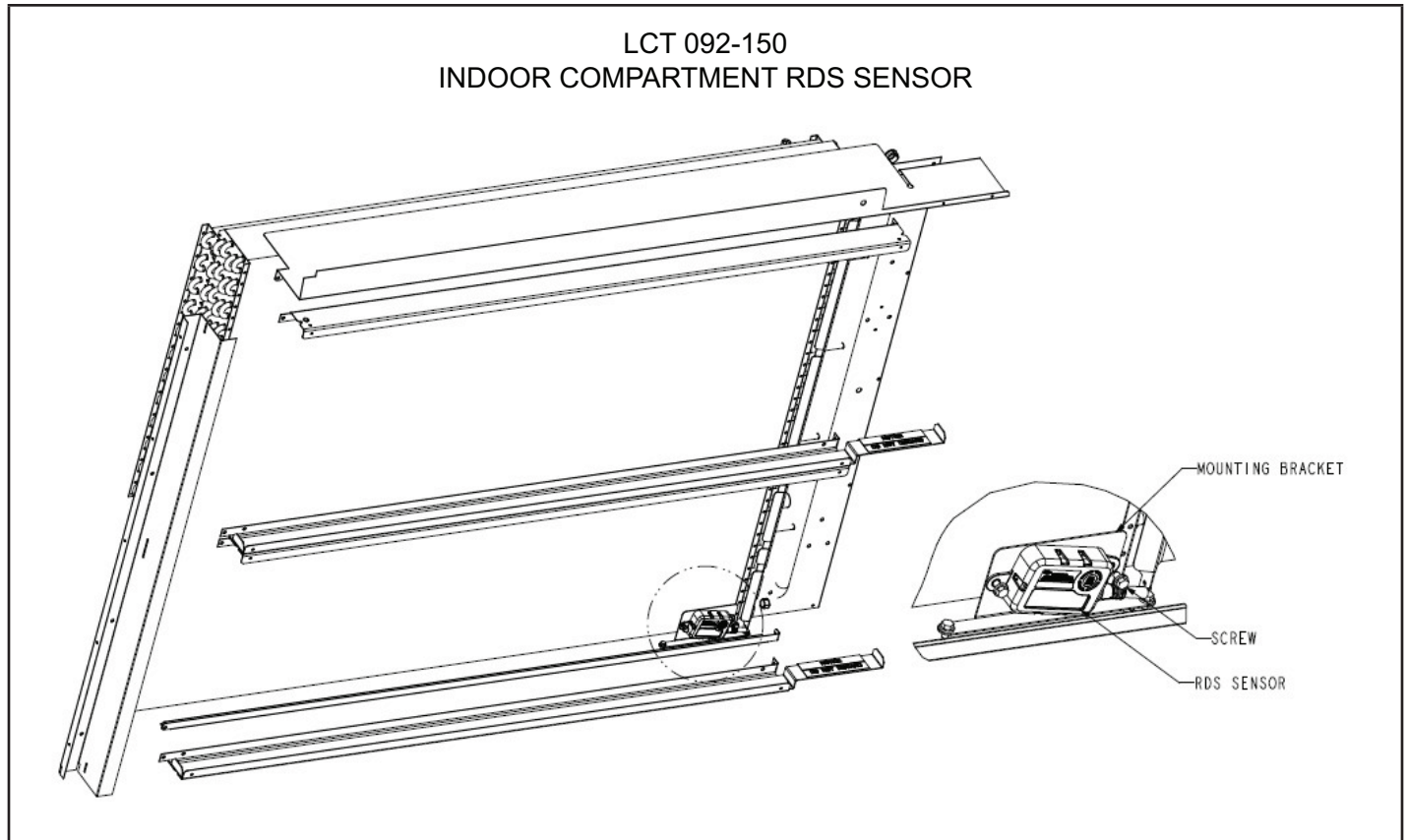

FIGURE 9

C-Blower Compartment

The blower compartment is located between the evaporator coil and the condenser coil section. The blower assembly is secured to a sliding frame which allows the blower motor assembly to be pulled out of the unit.

Units are equipped with variable speed, direct drive blowers. The supply CFM can be adjusted by changing the percentage of motor output using the Unit Controller settings. Measure the intake air CFM and adjust the RPM% to get design-specified supply air CFM.

1-Blower Wheels

Units are be equipped with a backward inclined blower wheel. See "SPECIFICATIONS" at the front this manual for more detail.

2-Indoor Blower Motor B3

Units are equipped with a direct drive blower assembly with a three-phase, variable speed, direct drive blower motor.

All motor specifications are listed in the SPECIFICATIONS (table of contents) in the front of this manual. Units may be equipped with motors manufactured by various manufacturers, therefore electrical FLA and LRA specifications will vary. See unit rating plate for information specific to your unit.

⚠ IMPORTANT

Compressor two is the only component that must be checked to ensure proper phasing. Follow "COOLING START-UP" section of installation instructions to ensure proper compressor and blower operation.

The Unit Controller checks the incoming power during start-up. If the voltage or phase is incorrect, the Unit Controller will display an alarm and the unit will not start.

A-Blower Operation

Refer to the Unit Controller Setup Guide to energize blower. Use the mobile service app menu; see SERVICE > TEST.

In thermostat control mode, the Unit Controller will stage the blower between low and high speed. In zone sensor control mode, the Unit Controller will vary (VAV) the blower between low and high speed.

⚠ WARNING

- 1-Make sure that unit is installed in accordance with the installation instructions and applicable codes.
- 2-Inspect all electrical wiring, both field- and factory installed, for loose connections. Tighten as required.
- 3-Check to ensure that refrigerant lines do not rub against the cabinet or against other refrigerant lines.
- 4-Check voltage at disconnect switch. Voltage must be within range listed on nameplate. If not, consult power company and have voltage condition corrected before starting unit.
- 5-Make sure filters are new and in place before start-up.

Initiate blower only (G) demand at thermostat according to instructions provided with thermostat. Unit will cycle on thermostat demand. The following steps apply to applications using a typical electro-mechanical thermostat.

1- Blower operation is manually set at the thermostat sub-base fan switch. With fan switch in ON position, blowers will operate continuously.

2- With fan switch in AUTO position, the blowers will cycle with demand. Blowers and entire unit will be off when system switch is in OFF position.

NOTE - Blower operation mode can also be initiated by the mobile service app.

Direct-drive motor may not immediately stop when power is interrupted to the Unit Controller. Disconnect unit power before opening the blower compartment. The Controller's digital inputs must be used to shut down the blower. See Unit Controller manual for operation sequences.

B-Blower Access

The blower assembly is secured to a sliding frame which allows the blower assembly to be pulled out of the unit. See FIGURE 11.

- 1 - Loosen the reusable wire tie which secures the controls and high voltage blower wiring to the blower housing. Disconnect the pressure sensor low voltage wire harness.
- 2 - Remove and retain screws on either side (and on the front for direct drive) of sliding frame. Use the metal handle to pull frame toward outside of unit.
- 3 - Slide frame back into original position when finished servicing. Reattach the blower wiring in the previous location using the wire tie. Reconnect pressure sensor low voltage wire harness.
- 4 - Replace retained screws.

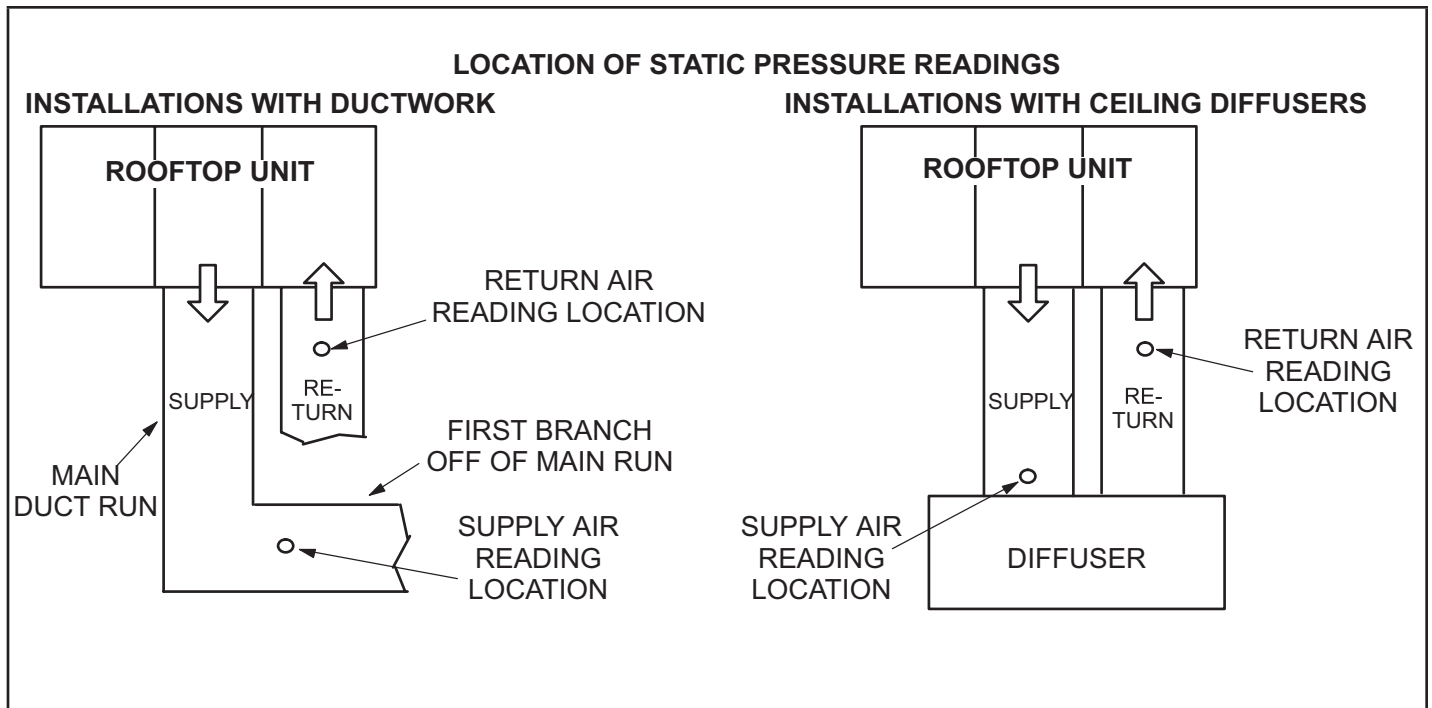

FIGURE 10

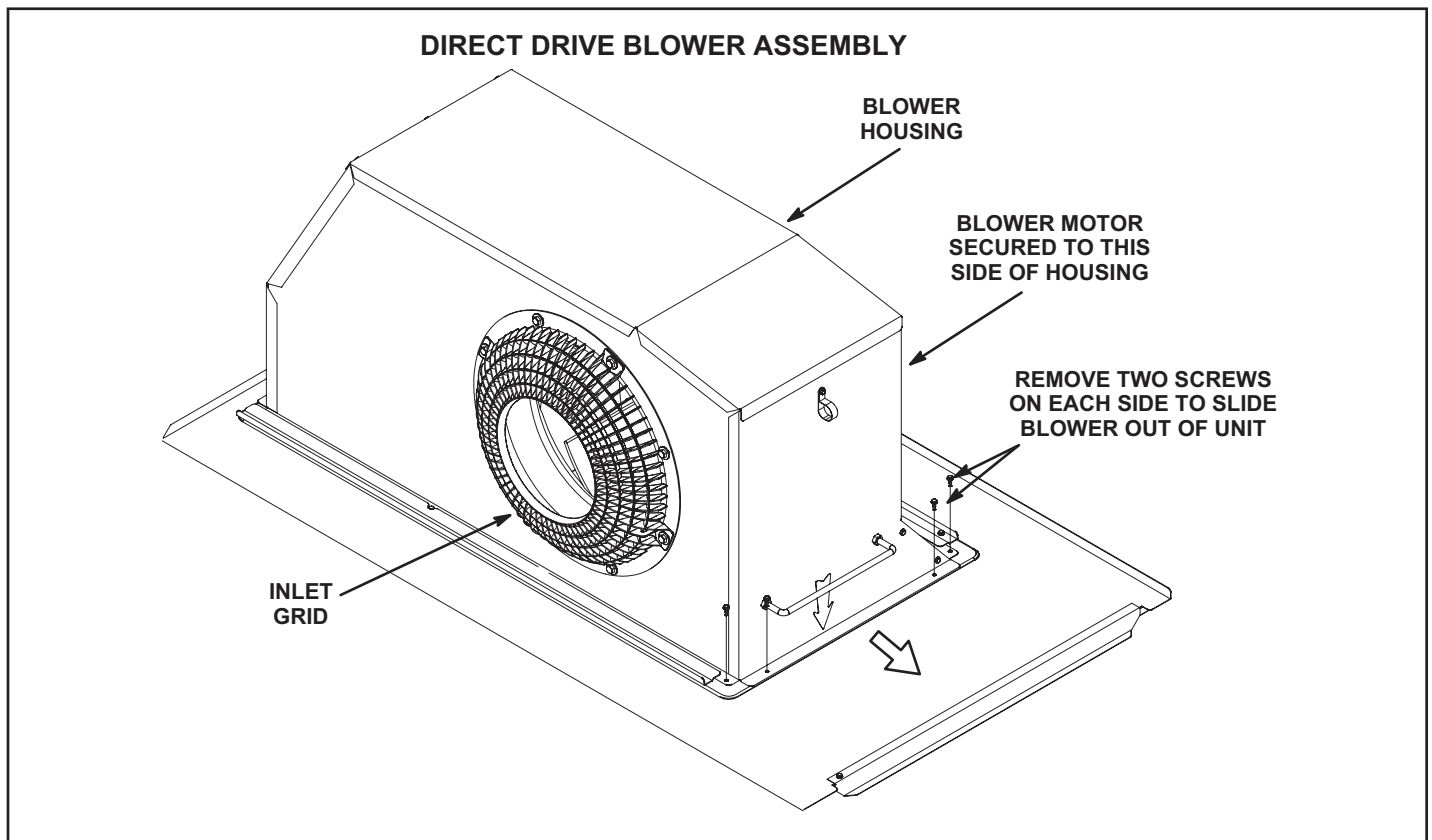

FIGURE 11

The supply CFM can be adjusted by changing the percentage of motor output using the Unit Controller settings. Refer to TABLE 5 for menu paths and default settings.. Record any RPM% changes on the parameter settings label located on the inside of the compressor access panel.

Use the mobile service app to navigate to the SET-UP>TEST & BALANCE>BLOWER menu. After the new RPM% values are entered, select START CALIBRATION. The blower calibration status is displayed as a % complete. Upon successful completion, the mobile service app will display CALIBRATION SUCCESS and go back to the blower calibration screen.

⚠ CAUTION
The BLOWER CALIBRATION process starts the indoor blower at operational speeds and moves the economizer damper blades. Before starting this process, replace any access panels and close all unit doors except compressor compartment door.

IMPORTANT - The default value for Cooling Low motor speed is lower than a traditional single- or two-speed unit. If operating the unit with a 2- or 3-stage controller (2- or 3-stage thermostat, DDC controller, etc.), it is recommended to increase the Cooling Low CFM default value to a suitable level for part load cooling (typically 60% of full load CFM).

Blower calibration is required only on units that are newly installed or if there is a change in the duct work or air filters after installation..

**TABLE 5
DIRECT DRIVE PARAMETER SETTINGS - 581102-01**

Parameter	Field Setting	Description
Note: Any changes to Smoke CFM setting must be adjusted before the other CFM settings. Use SETTINGS > RTU OPTIONS > EDIT PARAMETERS = 12 for EBM, 6 for ECM		
BLOWER SMOKE CFM	%	Percentage of RPM for blower smoke speed.
SETUP > TEST & BALANCE > BLOWER		
BLOWER HEATING HIGH CFM	%	Percentage of RPM for blower heating high speed.
BLOWER HEATING LOWCFM	%	Percentage of RPM for blower heating low speed (P volt gas heat only).
BLOWER COOLING HIGH CFM	%	Percentage of RPM for blower cooling high speed.
BLOWER COOLING LOW CFM	%	Percentage of RPM for blower cooling low speed and vent speed for standard static blowers.
BLOWER VENTILATION CFM	%	Percentage of RPM for high static blower ventilation speed.
SETUP > TEST & BALANCE > DAMPER		
BLOWER HIGH CFM DAMPER POS %	%	Minimum damper position for high speed blower operation. Default 0%.
BLOWER LOW CFM DAMPER POS %	%	Minimum damper position for low speed blower operation. Default 0%.
POWER EXHAUST DAMPER POS %	%	Minimum damper position for low power exhaust operation. Default 50%.
SETTINGS > RTU OPTIONS > EDIT PARAMETERS = 216		
POWER EXHAUST DEADBAND %	%	Deadband % for power exhaust operation. Default 10%.
SETTINGS > RTU OPTIONS > EDIT PARAMETERS = 10 (Applies to Thermostat Mode ONLY)		
FREE COOLING STAGE-UP DELAY	sec	Number of seconds to hold blower at low speed before switching to blower at high speed. Default 300 seconds.

Installer: Record any parameter changes under “Field Setting” column. Settings need to be recorded by installer for use when Unit Controller is replaced or reprogrammed.

D-Electric Heat Components

See ELECTRICAL / ELECTRIC HEAT DATA and ELECTRIC HEAT CAPACITIES (table of contents) for electric heat match-ups and electrical ratings.

Electric heat is shown in FIGURE 12. All electric heat sections consist of electric heating elements exposed directly to the air stream.

1-Heating Elements HE1, HE2

Heating elements are composed of helix wound bare nichrome wire exposed directly to the air stream. Three elements are connected in a three-phase arrangement. The elements in 208/230V units are connected in a "Delta" arrangement. Elements in 460 and 575V units are connected in "Wye" arrangement. Each stage is energized independently by the corresponding contactors located on the electric heat vestibule panel. Once energized, heat transfer is instantaneous. High temperature protection is provided by primary and redundant high temperature limits and overcurrent protection is provided by fuses.

2-Contactors K15, K16

Contactors K15 and K16 are three-pole double-break contactors located on the electric heat vestibule. All contactors are equipped with a 24VAC coil and are energized by the A55 Unit Controller. Contactors energize the first and only stage of heating elements.

3-Primary Limit Switch S15

S15 is a SPST N.C. auto-reset switch located on the back panel of the electric heat section below the heating elements. The switch is wired in series with the first stage contactor coil. When S15 opens, indicating a problem in the system, contactor K15 is de-energized. When K15 is de-energized, first stage and all subsequent stages of heat are de-energized. The switch is factory-set to open at $200^{\circ}\text{F} \pm 5^{\circ}\text{F}$ ($93.3^{\circ}\text{C} \pm 2.8^{\circ}\text{C}$) on a temperature rise and automatically reset at $160^{\circ}\text{F} \pm 6^{\circ}\text{F}$ ($71.1^{\circ}\text{C} \pm 3.3^{\circ}\text{C}$) on a temperature fall. The switch is not adjustable.

4-High Temperature Thermostat S19

S19 is a SPST N.C. auto-reset thermostat located on the back panel of the electric heat section below the heating elements. The thermostat is wired in series with the first stage contactor coil. When either S15 or S19 opens, indicating a problem in the system, contactor K15 is de-energized.

When K15 is de-energized, first stage and all subsequent stages of heat are de-energized. The thermostat is factory-set to open at $170^{\circ}\text{F} \pm 5^{\circ}\text{F}$ ($76.7^{\circ}\text{C} \pm 2.8^{\circ}\text{C}$) on a temperature rise and automatically reset at $130^{\circ}\text{F} \pm 6^{\circ}\text{F}$ ($54.4^{\circ}\text{C} \pm 3.3^{\circ}\text{C}$) on a temperature fall. The thermostat is not adjustable.

5-High Temperature Limits S20, S158

Limits are SPST N.C. manual-reset thermostats. Like the primary temperature limit, S20 is wired in series with the first-stage contactor coil (K15). When S20 opens, heating elements (HE1, HE2) are de-energized. S158 is wired in series with the second-stage contactor coil (K16). When S158 opens, heating elements (HE1, HE2) are de-energized. When the contactors are de-energized, first-stage and all subsequent stages of heat are de-energized. The thermostat is factory-set to open at $220^{\circ}\text{F} \pm 6^{\circ}\text{F}$ ($104^{\circ}\text{C} \pm 3.3^{\circ}\text{C}$) on a temperature rise and can be manually reset when temperature falls below 160°F (71.0°C).

6-Terminal Strip TB2

Terminal strip TB2 is used for single point power installations only. TB2 distributes L1, L2 and L3 power to TB3. Units with multi-point power connection do not use TB2.

7-Terminal Strip TB3

Electric heat line voltage connections are made to terminal strip TB3, located in the upper left corner+ of the electric heat vestibule. TB3 distributes power to the electric heat components.

8-Fuse F3 and F42

Fuses are housed in a fuse block which holds three fuses. Each fuse is connected in series with each leg of electric heat. Figure 11 and TABLE 6 show the fuses used with each electric heat section. For simplicity, the service manual labels the fuses F3 - 1, 2 and F42 - 1, 2.

9-Unit Fuse Block F4

Three line voltage fuses provide short circuit and ground fault protection to all cooling components in units equipped with electric heat. The fuses are rated in accordance with the amperage of the cooling components.

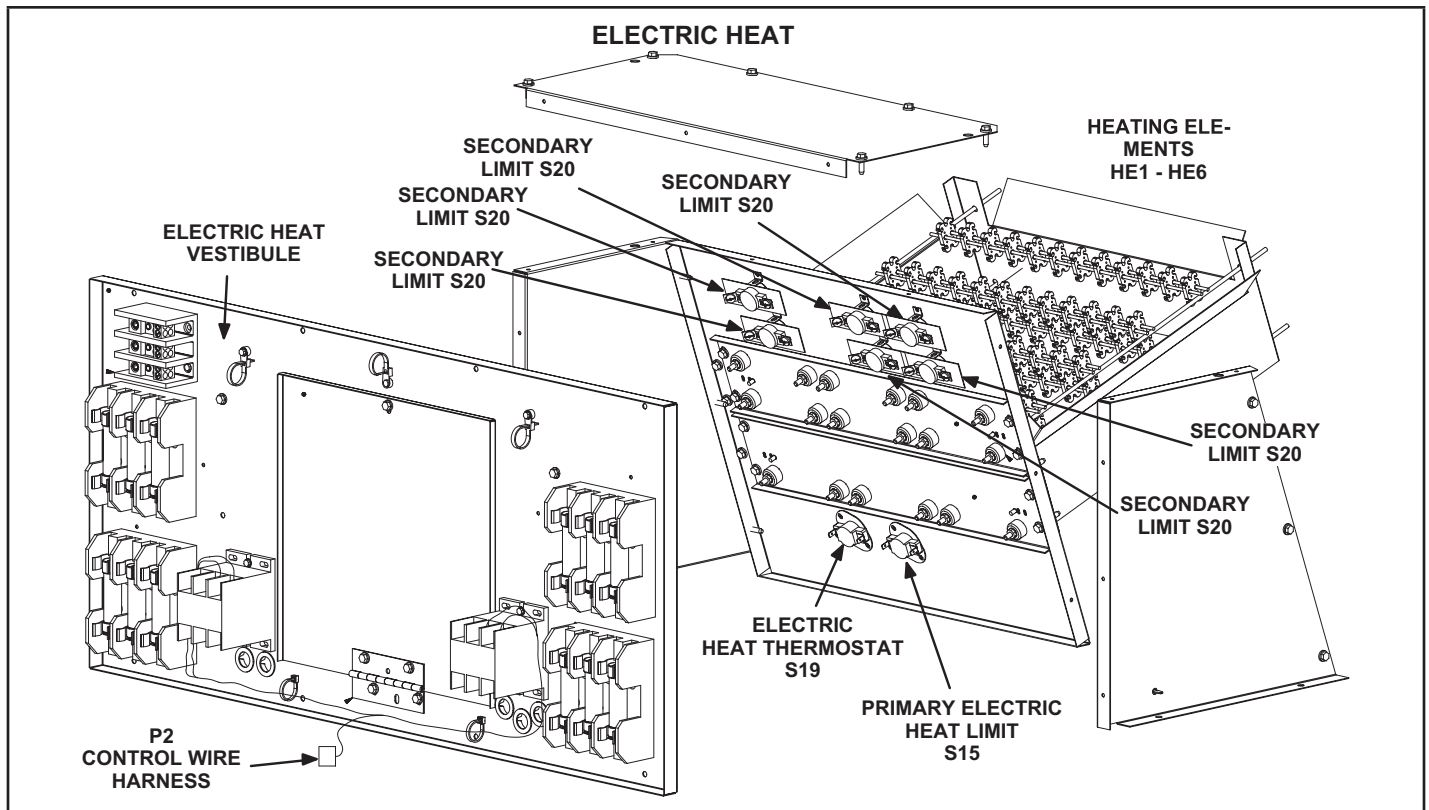

FIGURE 12

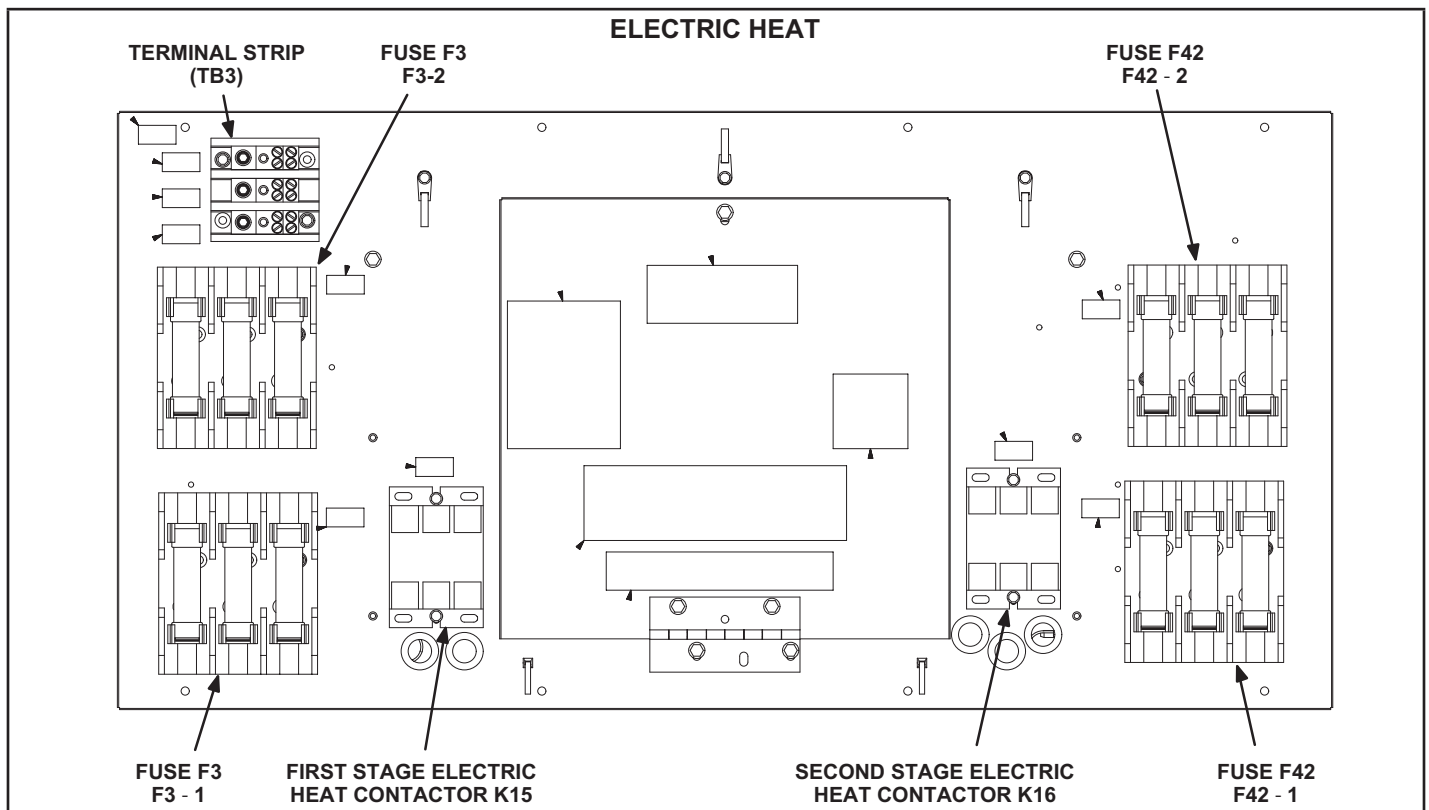

FIGURE 13

TABLE 6

ELECTRIC HEAT SECTION FUSE RATING					
EHA QUANTITY & SIZE	VOLTAGES	FUSE (3 each)			
		F3-1	F3-2	F42-1	F42-2
EHO075-1, 7.5	208/230		25 Amp 250V		
	460		15 Amp 600V		
	575		10 Amp 600V		
EHO150-1, 15	208/230		50 Amp 250V		
	460		25 Amp 600V		
	575		20 Amp 600V		
EHO225-1, 22.5	208/230	50 Amp 250V		25 Amp 250V	
	460	25 Amp 600V		15 Amp 600V	
	575	20 Amp 600V		10 Amp 600V	
EHO300-1, 30	208/230	50 Amp 250V		50 Amp 250V	
	460	25 Amp 600V		25 Amp 600V	
	575	20 Amp 600V		20 Amp 600V	
EHO450-1, 45	208/230	50 Amp 250V		60 Amp 250V	60 Amp 250V
	460	25 Amp 600V		50 Amp 600V	
	575	20 Amp 600V		40 Amp 600V	
EHO600-1, 60	208/230	60 Amp 250V	60 Amp 250V	60 Amp 250V	60 Amp 250V
	460	50 Amp 600V		50 Amp 600V	
	575	40 Amp 600V		40 Amp 600V	

II-PLACEMENT AND INSTALLATION

Make sure the unit is installed in accordance with the installation instructions and all applicable codes. See accessories section for conditions requiring use of the optional roof mounting frame (C1CURB10).

III-CHARGING

A-Refrigerant Charge and Check

WARNING-Do not exceed nameplate charge under any condition.

This unit is factory charged and should require no further adjustment. If the system requires additional refrigerant, reclaim the charge, evacuate the system, and add required nameplate charge.

Refrigerant Charge R-454B		
Unit	M _c (lbs)	M _c (kg)
LCT092 STG 1	6.25	2.83
LCT092 STG 2	5.88	2.67
LCT102 STG 1	6.25	2.83
LCT102 STG 2	5.88	2.67
LCT120 STG 1	5.88	2.67
LCT120 STG 2	5.88	2.67
LCT150 STG 1	5.75	2.61
LCT150 STG 2	6.25	2.83
LCT092 W/ Humidrol STG 1	6.5	2.95
LCT092 W/ Humidrol STG 2	5.88	2.67
LCT102 W/ Humidrol STG 1	6.5	2.95
LCT102 W/ Humidrol STG 2	5.88	2.67
LCT120 W/ Humidrol STG 1	6.25	2.83
LCT120 W/ Humidrol STG 2	5.88	2.67
LCT150 W/ Humidrol STG 1	6.13	2.78
LCT150 W/ Humidrol STG 2	6.25	2.83

When breaking into the refrigerant circuit to make repairs – or for any other purpose – conventional procedures shall be used. However, for flammable refrigerants it is important that best practice be followed and, since flammability is a consideration, the following procedure shall be adhered to:

- Safely remove refrigerant following local and national regulations,
- Evacuate the circuit,
- Purge the circuit with inert gas,
- Evacuate,
- Purge with inert gas,
- Open the circuit

The refrigerant charge shall be recovered into the correct recovery cylinders if venting is not allowed by local and national codes. For appliances containing flammable refrigerants, the system shall be purged with oxygen-free nitrogen to render the appliance safe for flammable refrigerants. This process might need to be repeated several

times. Compressed air or oxygen shall not be used for purging refrigerant systems. Refrigerant purging shall be achieved by breaking the vacuum in the system with oxygen-free nitrogen and continuing to fill until the working pressure is achieved, then venting to atmosphere, and finally pulling down to a vacuum. This process shall be repeated until no refrigerant is within the system. When the final oxygen-free nitrogen charge is used, the system shall be vented down to atmospheric pressure to enable work to take place. Ensure that the outlet for the vacuum pump is not close to any potential ignition sources and that ventilation is available.

In addition to conventional charging procedures, the following requirements shall be followed.

- Ensure that contamination of different refrigerants does not occur when using charging equipment. Hoses or lines shall be as short as possible to minimize the amount of refrigerant contained in them.
- Cylinders shall be kept in an appropriate position according to the instructions.
- Ensure that the refrigerating unit is earthed prior to charging the system with refrigerant.
 - Label the system when charging is complete (if not already).
 - Extreme care shall be taken not to overfill the refrigerating unit.

Prior to recharging the system, it shall be pressure-tested with the appropriate purging gas. The system shall be leak-tested on completion of charging but prior to commissioning. A follow up leak test shall be carried out prior to leaving the site.

- When removing refrigerant from a system, either for servicing or decommissioning, it is recommended good practice that all refrigerants are removed safely. When transferring refrigerant into cylinders, ensure that only appropriate refrigerant recovery cylinders are employed. Ensure that the correct number of cylinders for holding the total system charge is available. All cylinders to be used are designated for the recovered refrigerant and labelled for that refrigerant (i. e. special cylinders for the recovery of refrigerant). Cylinders shall be complete with pressure-relief valve and associated shut-off valves in good working order. Empty recovery cylinders are evacuated and, if possible, cooled before recovery occurs.
- The recovery equipment shall be in good working order with a set of instructions concerning the equipment that is at hand and shall be suitable for the recovery of all appropriate refrigerants including, when applicable, flammable refrigerants. In addition, a set of calibrated weighing scales shall be available and in good working order. Hoses shall be complete with leak-free disconnect couplings and in good condition. Before using the recovery machine, check that it is in satisfactory working order,

has been properly maintained and that any associated electrical components are sealed to prevent ignition in the event of a refrigerant release. Consult manufacturer if in doubt.

- The recovered refrigerant shall be returned to the refrigerant supplier in the correct recovery cylinder, and the relevant waste transfer note arranged. Do not mix refrigerants in recovery units and especially not in cylinders.
- If compressors or compressor oils are to be removed, ensure that they have been evacuated to an acceptable level to make certain that flammable refrigerant does not remain within the lubricant. The evacuation process shall be carried out prior to returning the compressor to the suppliers. Only electric heating to the compressor body shall be employed to accelerate this process. When oil is drained from a system, it shall be carried out safely.

NOTE - System charging is not recommended below 60F (15C). In temperatures below 60F (15C), the charge must be weighed into the system.

If weighing facilities are not available, or to check the charge, use the following procedure:

IMPORTANT - Charge unit in standard cooling mode.

- 1 - Make sure outdoor coil is clean. Attach gauge manifolds and operate unit at full CFM in cooling mode with economizer disabled until system stabilizes (approximately five minutes). Make sure all outdoor air dampers are closed. operate the unit in cooling mode at high speed using the following mobile service app menu path:

RTU MENU > COMPONENT TEST > COOLING >
COOLING STAGE 3

- 2 - Compare the normal operating pressures to the pressures obtained from the gauges. Check unit components if there are significant differences.
- 3 - Measure the outdoor ambient temperature and the suction pressure. Refer to the charging curve to determine a target liquid temperature.
Note - Pressures are listed for sea level applications.
- 4 - Use the same thermometer to accurately measure the liquid temperature (in the outdoor section).
 - If measured liquid temperature is higher than the target liquid temperature, add refrigerant to the system.
 - If measured liquid temperature is lower than the target liquid temperature, recover some refrigerant from the system.
- 5 - Add or remove charge in increments. Allow the system to stabilize each time refrigerant is added or removed.
- 6 - Continue the process until measured liquid temperature agrees with the target liquid temperature. Do not go below the target liquid temperature when adjusting charge. Note that suction pressure can change as charge is adjusted.
- 7 - Example: For an LCT092, at 95°F outdoor ambient and a measured suction pressure of 130psig, the target liquid temperature is 95°F. For a measured liquid temperature of 106°F, add charge in increments until measured liquid temperature agrees with the target liquid temperature.

**TABLE 7 581249-01
LCT092**

Normal Operating Pressures												
Outdoor Coil Entering Air Temperature												
	65°F		75°F		85°F		95°F		105°F		115°F	
	Suct (psig)	Disc (psig)	Suct (psig)	Disc (psig)	Suct (psig)	Disc (psig)	Suct (psig)	Disc (psig)	Suct (psig)	Disc (psig)	Suct (psig)	Disc (psig)
Circuit 1	95	214	96	252	98	295	100	343	102	397	105	456
	104	216	105	253	107	295	109	343	111	397	114	456
	122	222	123	257	125	299	127	346	130	398	133	456
	140	229	142	264	144	305	146	351	149	402	152	459
Circuit 2	111	221	113	258	114	300	116	347	118	398	120	455
	121	224	122	260	123	302	125	349	128	400	130	456
	140	230	141	266	143	307	145	353	148	404	150	460
	159	238	161	273	163	314	165	359	168	410	171	465

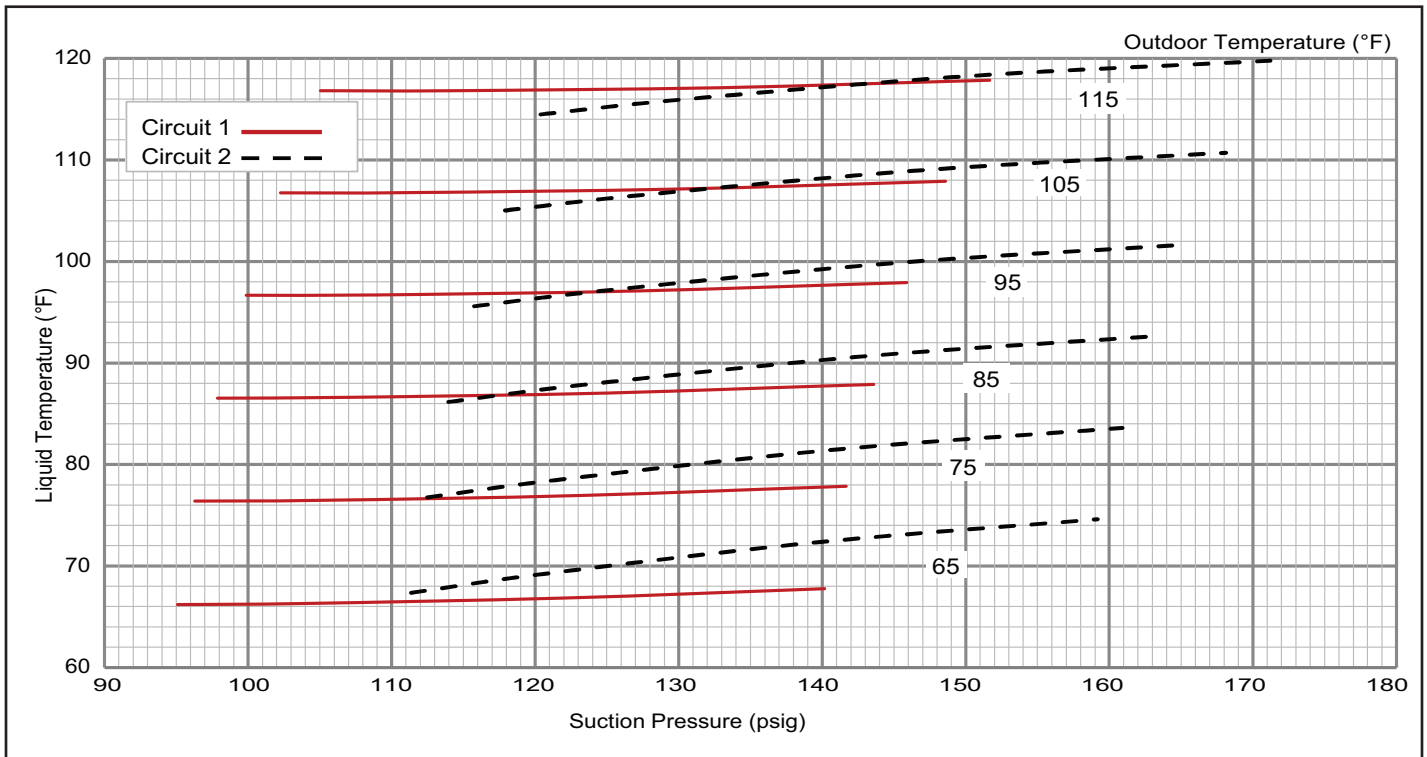
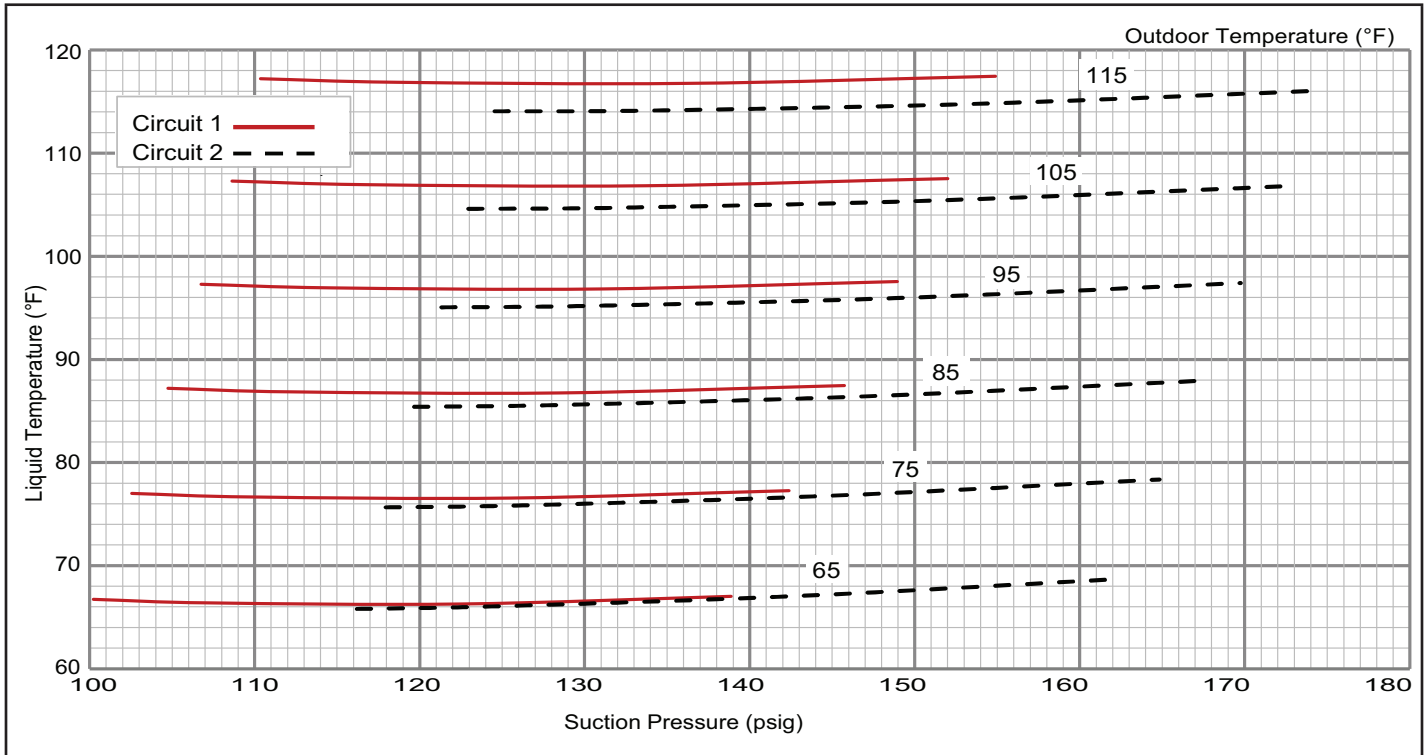

TABLE 8 581250-01
LCT092 w/ Reheat

Normal Operating Pressures												
Outdoor Coil Entering Air Temperature												
	65°F		75°F		85°F		95°F		105°F		115°F	
	Suct (psig)	Disc (psig)	Suct (psig)	Disc (psig)	Suct (psig)	Disc (psig)	Suct (psig)	Disc (psig)	Suct (psig)	Disc (psig)	Suct (psig)	Disc (psig)
Circuit 1	100	224	103	260	105	300	107	345	109	395	110	449
	107	225	110	261	112	301	115	346	117	396	119	450
	122	230	126	266	128	307	131	352	134	402	136	456
	139	241	142	277	146	318	149	363	152	413	155	468
Circuit 2	116	222	118	257	120	297	121	343	123	394	125	450
	125	223	127	258	129	298	130	344	132	395	134	451
	143	228	145	263	147	303	149	349	151	400	153	456
	162	237	165	272	167	312	170	358	172	409	175	465



**TABLE 9 581251-01
LCT102**

Normal Operating Pressures												
Outdoor Coil Entering Air Temperature												
	65°F		75°F		85°F		95°F		105°F		115°F	
	Suct (psig)	Disc (psig)	Suct (psig)	Disc (psig)	Suct (psig)	Disc (psig)	Suct (psig)	Disc (psig)	Suct (psig)	Disc (psig)	Suct (psig)	Disc (psig)
Circuit 1	98	219	100	255	102	297	104	345	107	399	109	459
	106	221	108	257	111	298	113	346	115	399	118	459
	123	228	126	263	128	303	130	350	133	403	135	462
	141	237	144	271	146	311	149	357	151	409	154	467
Circuit 2	112	228	113	264	115	306	117	352	119	404	121	462
	121	231	122	266	124	307	126	354	128	405	130	462
	139	238	141	273	143	313	145	358	147	409	150	465
	159	248	161	282	163	321	166	365	168	415	171	470

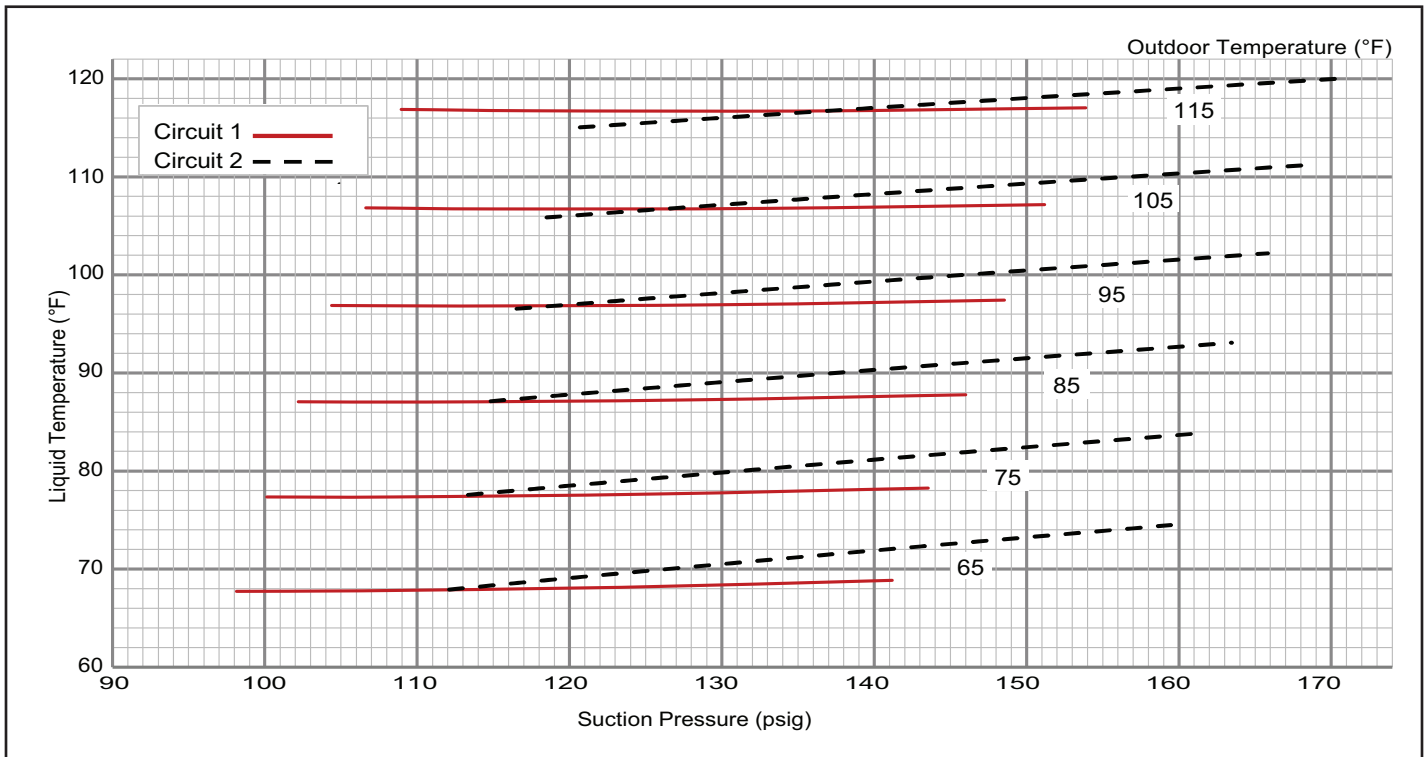

**TABLE 10 581252-01
LCT102 w/ Reheat**

Normal Operating Pressures												
Outdoor Coil Entering Air Temperature												
	65°F		75°F		85°F		95°F		105°F		115°F	
	Suct (psig)	Disc (psig)	Suct (psig)	Disc (psig)	Suct (psig)	Disc (psig)	Suct (psig)	Disc (psig)	Suct (psig)	Disc (psig)	Suct (psig)	Disc (psig)
Circuit 1	98	228	101	267	104	314	107	370	109	435	112	509
	106	227	109	264	112	310	115	365	117	429	120	501
	122	232	125	266	128	309	131	362	134	423	137	493
	139	245	143	277	146	318	149	368	153	426	156	494
Circuit 2	112	225	115	262	117	306	119	357	121	415	122	479
	120	227	123	263	126	307	128	357	130	414	131	477
	139	234	142	269	145	311	147	360	149	415	150	477
	159	245	162	279	165	319	168	367	170	421	172	482

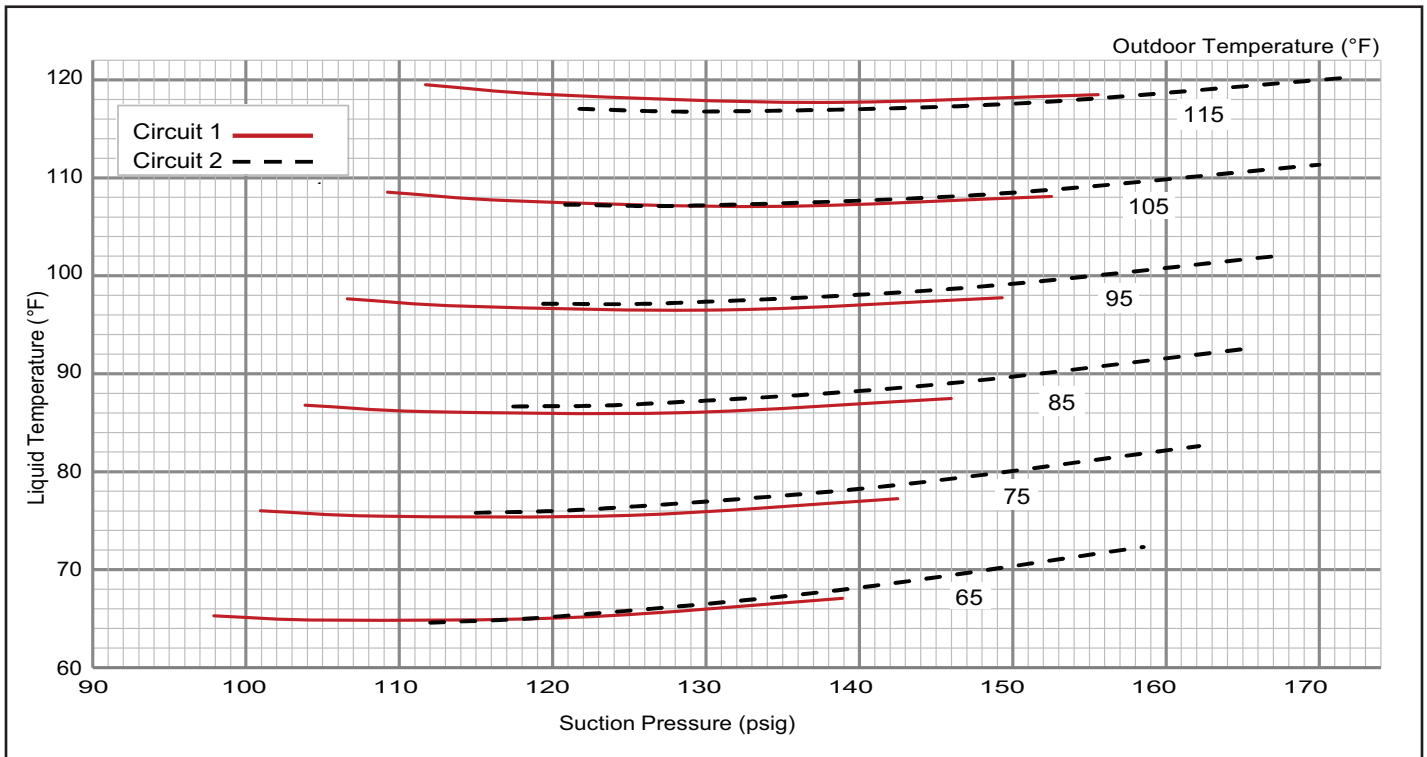

**TABLE 11 581253-01
LCT120**

Normal Operating Pressures												
Outdoor Coil Entering Air Temperature												
	65°F		75°F		85°F		95°F		105°F		115°F	
	Suct (psig)	Disc (psig)	Suct (psig)	Disc (psig)	Suct (psig)	Disc (psig)	Suct (psig)	Disc (psig)	Suct (psig)	Disc (psig)	Suct (psig)	Disc (psig)
Circuit 1	95	228	97	266	100	310	102	357	105	409	108	466
	104	229	106	268	108	311	111	358	114	411	117	467
	120	235	123	273	126	316	128	363	132	415	135	471
	138	242	141	280	144	323	147	370	150	422	154	478
Circuit 2	112	233	113	273	114	318	114	369	115	425	116	487
	120	237	121	276	122	320	123	370	124	425	125	486
	136	246	138	283	140	326	142	373	144	427	146	486
	155	256	157	292	160	332	163	378	166	430	169	487

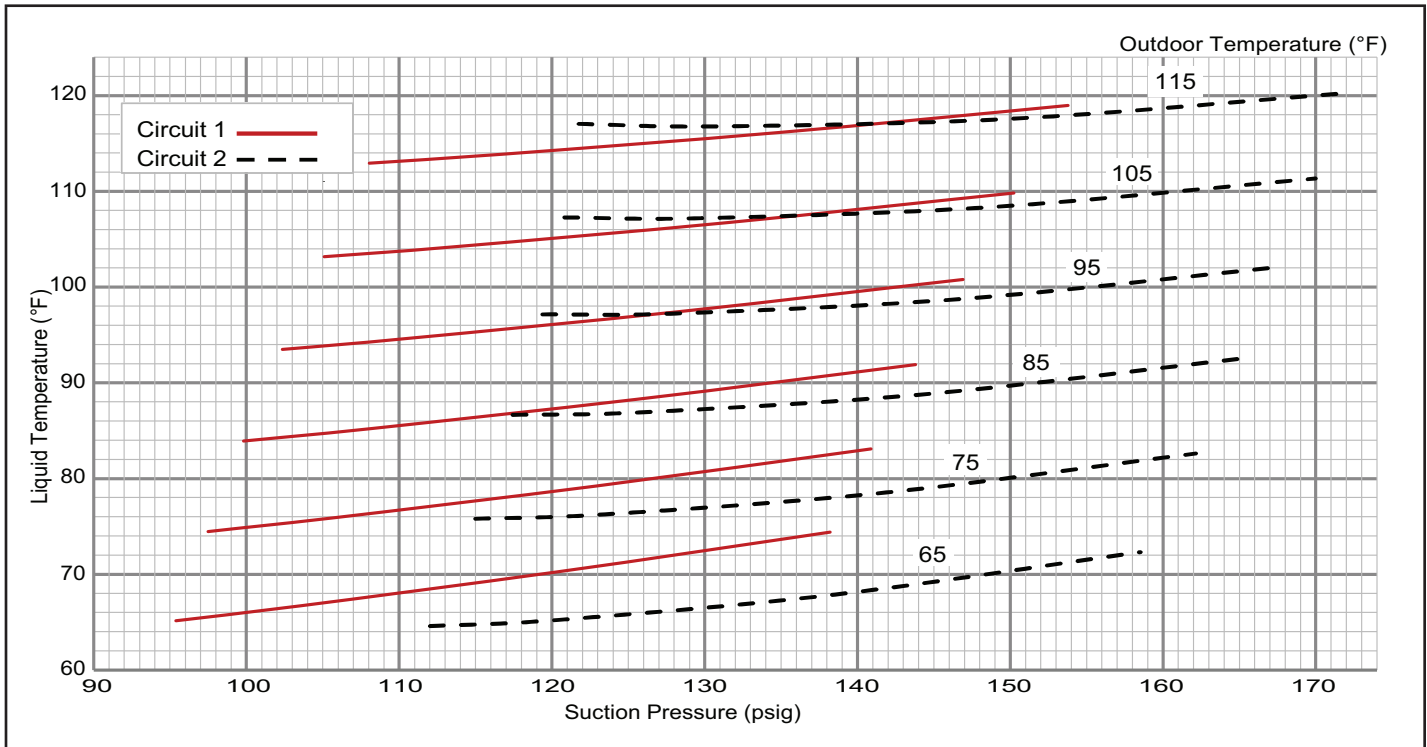
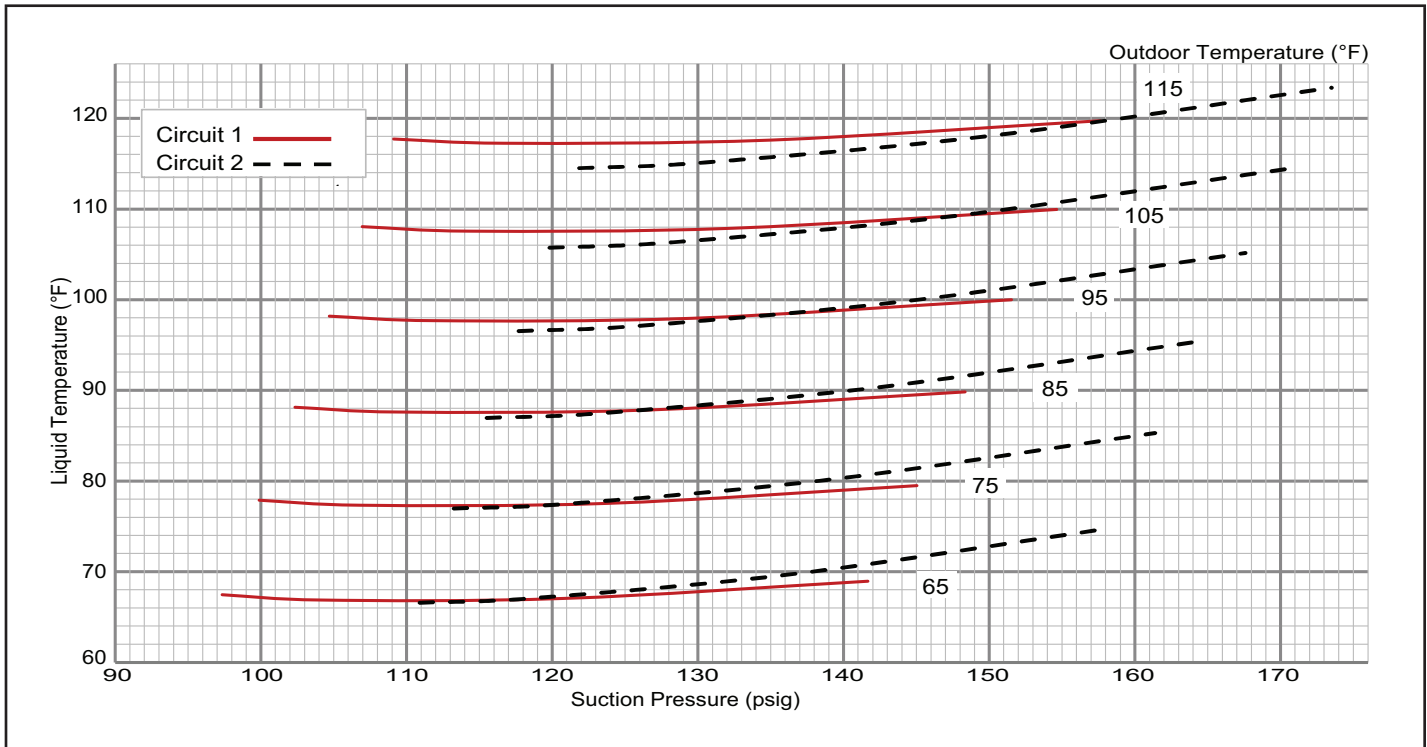

TABLE 12 581254-01
LCT120 w/ Reheat

Normal Operating Pressures												
Outdoor Coil Entering Air Temperature												
	65°F		75°F		85°F		95°F		105°F		115°F	
	Suct (psig)	Disc (psig)	Suct (psig)	Disc (psig)	Suct (psig)	Disc (psig)	Suct (psig)	Disc (psig)	Suct (psig)	Disc (psig)	Suct (psig)	Disc (psig)
Circuit 1	97	240	100	278	102	322	105	371	107	427	109	489
	104	241	107	278	109	321	112	370	114	425	117	486
	121	247	124	283	127	325	130	373	132	427	135	487
	142	262	145	297	148	337	152	384	155	437	158	495
Circuit 2	111	240	113	279	116	322	118	370	120	422	122	479
	119	242	121	280	124	323	126	370	128	423	131	480
	137	248	140	286	142	329	145	376	148	428	150	484
	158	260	161	297	165	340	168	387	171	438	174	495



**TABLE 13 581255-01
LCT150**

Normal Operating Pressures												
Outdoor Coil Entering Air Temperature												
	65°F		75°F		85°F		95°F		105°F		115°F	
	Suct (psig)	Disc (psig)	Suct (psig)	Disc (psig)	Suct (psig)	Disc (psig)	Suct (psig)	Disc (psig)	Suct (psig)	Disc (psig)	Suct (psig)	Disc (psig)
Circuit 1	93	233	95	272	98	316	100	365	102	418	104	476
	101	234	103	273	106	317	108	365	111	418	113	476
	117	241	120	280	123	323	126	370	128	422	131	479
	134	253	138	291	141	333	144	380	147	431	150	488
Circuit 2	107	255	108	297	109	345	110	399	111	459	113	525
	114	258	116	299	117	346	119	399	120	457	122	522
	130	270	132	308	134	352	137	402	139	458	142	520
	147	289	150	324	153	366	156	413	160	466	163	525

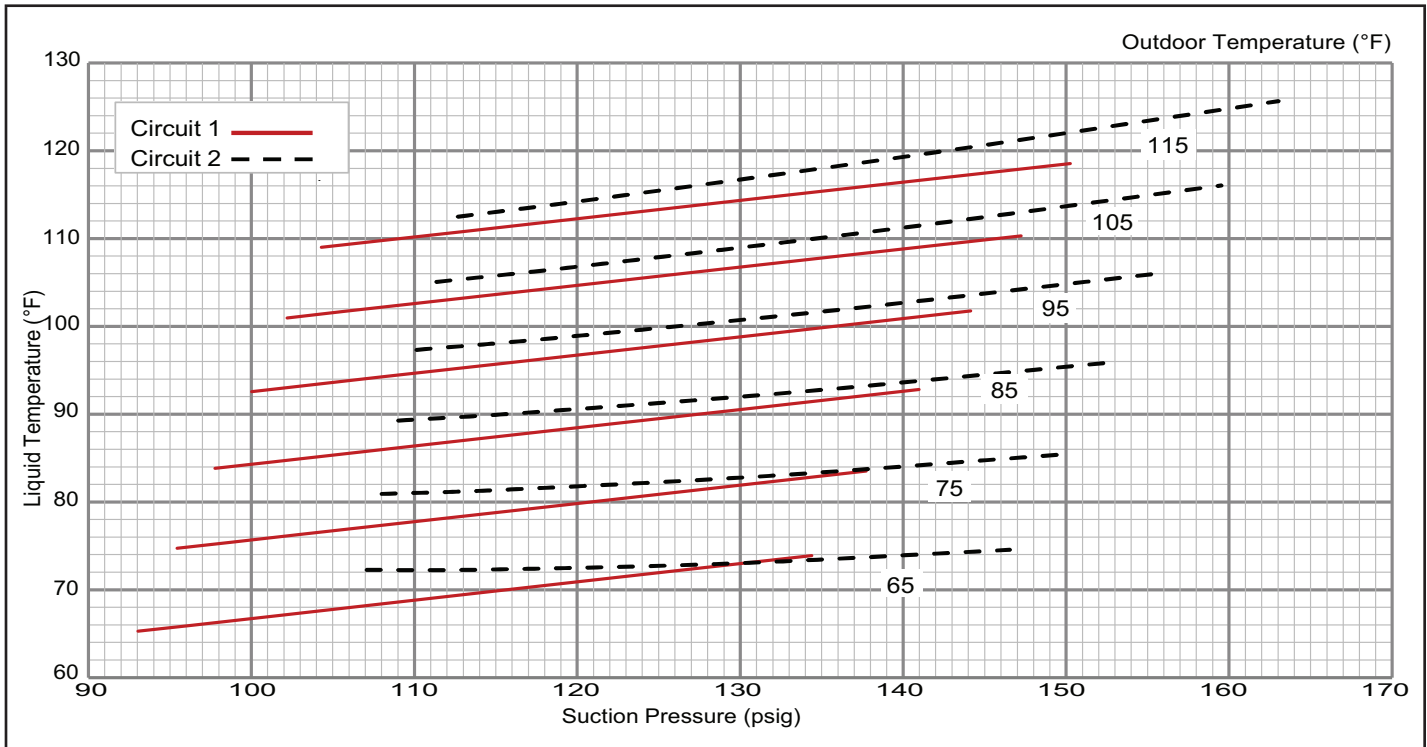
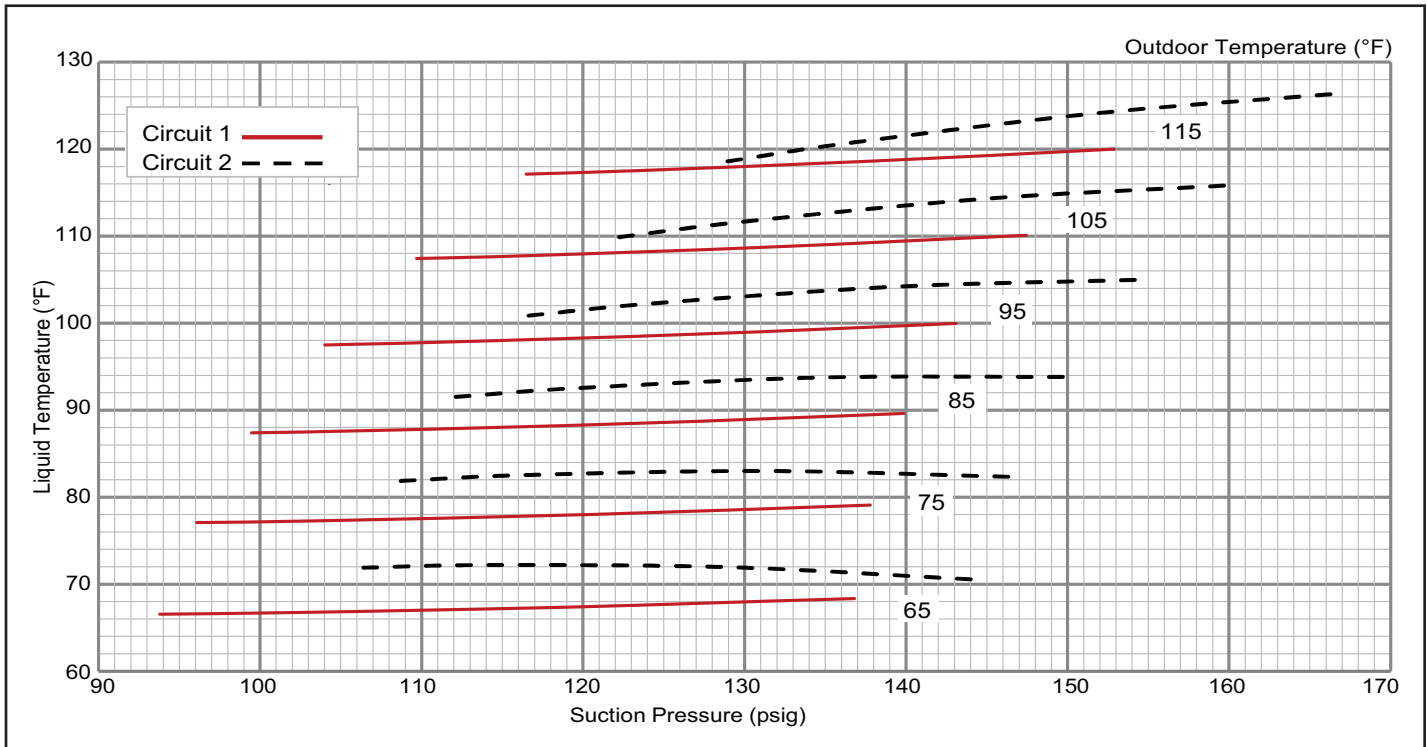

TABLE 14 581256-01
LCT150 w/ Reheat

Normal Operating Pressures												
Outdoor Coil Entering Air Temperature												
	65°F		75°F		85°F		95°F		105°F		115°F	
	Suct (psig)	Disc (psig)	Suct (psig)	Disc (psig)	Suct (psig)	Disc (psig)	Suct (psig)	Disc (psig)	Suct (psig)	Disc (psig)	Suct (psig)	Disc (psig)
Circuit 1	94	245	96	281	99	323	104	371	110	426	116	487
	102	249	104	284	107	326	111	374	117	428	123	489
	119	258	120	292	123	333	127	380	132	434	138	494
	137	269	138	303	140	343	143	389	147	442	153	501
Circuit 2	106	253	109	292	112	336	117	386	122	442	129	503
	114	258	116	297	120	340	124	390	130	445	137	507
	129	270	131	307	135	351	139	399	145	454	152	515
	144	283	146	320	150	362	154	410	160	464	167	524



IV-START-UP - OPERATION

Refer to start-up directions and to the unit wiring diagram when servicing. See unit nameplate for minimum circuit ampacity and maximum fuse size.

A-Preliminary and Seasonal Checks

- 1 - Make sure the unit is installed in accordance with the installation instructions and applicable codes.
- 2 - Inspect all electrical wiring, both field and factory installed for loose connections. Tighten as required. Refer to unit diagram located on inside of unit control box cover.
- 3 - Check to ensure that refrigerant lines are in good condition and do not rub against the cabinet or other refrigerant lines.
- 4 - Check voltage. Voltage must be within the range listed on the nameplate. If not, consult power company and have the voltage corrected before starting the unit.
- 5 - Recheck voltage and amp draw with unit running. If voltage is not within range listed on unit nameplate, stop unit and consult power company. Refer to unit nameplate for maximum rated load amps.

B-Cooling Start-up See FIGURE 14

NOTE-Crankcase heaters must be energized 24 hours before attempting to start compressor. Set thermostat so that there is no demand to prevent compressor from cycling. Apply power to unit.

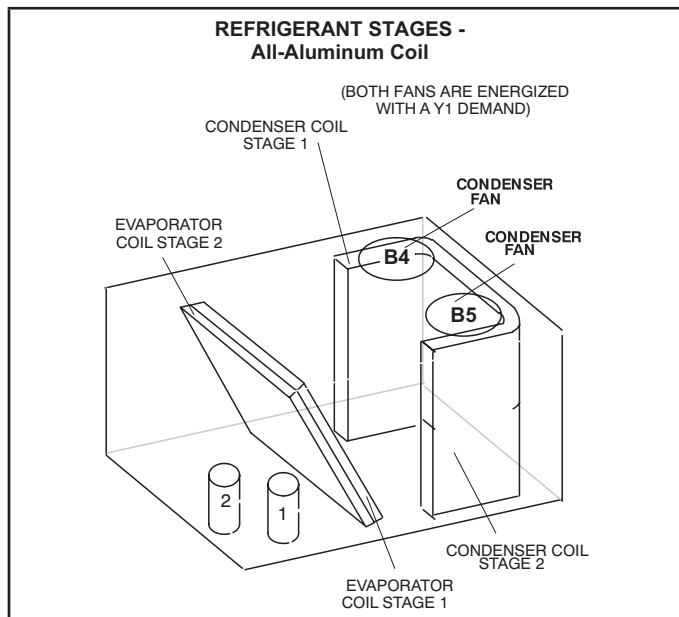

FIGURE 14

- 1 - Initiate first, second or third stage cooling demands according to instructions provided with thermostat or from the mobile service app at the following path:

RTU MENU > SERVICE > COMPONENT TEST > COOLING > COOLING STAGE 1/2/3

- 2 - With 2-stage cooling thermostat, the first-stage thermostat demand will energize compressor 1 Full Load. Second-stage thermostat demand will energize compressor 2.

With 3-stage cooling thermostat, the first-stage thermostat demand will energize compressor 1 Part Load. Second-stage thermostat demand will energize compressor 2.

Third-stage thermostat demand will energize compressor 1 Full Load and Compressor 2

- 3 - Units contain two refrigerant circuits or stages.
- 4 - Each refrigerant circuit is separately charged with refrigerant. See unit rating plate for correct amount of charge.

V- SYSTEMS SERVICE CHECKS

A-Electrical

- 1 - Check all wiring for loose connections.
- 2 - Check for correct voltage at unit (unit operating).
- 3 - Check amp-draw on both condenser fan motor and blower motor.

Fan Motor Rating Plate ____ Actual _____

Indoor Blower Motor Rating Plate ____ Actual _____

VI-ACCESSORIES

The accessories section describes the application of most of the optional accessories which can be factory or field installed to the LCT units.

A-Mounting Frames

When installing units on a combustible surface for down-flow discharge applications, a C1CURB roof mounting frame is used. The roof mounting frames are recommended in all other applications but not required. If the LCT units are not mounted on a flat (roof) surface, they MUST be supported under all edges and under the middle of the unit to prevent sagging. The units MUST be mounted level within 1/16" per linear foot or 5mm per meter in any direction.

The assembled C1CURB mounting frame is shown in FIGURE 15. Refer to the roof mounting frame installation instructions for details of proper assembly and mounting. The roof mounting frame MUST be squared to the roof and level before mounting. Plenum system MUST be installed before the unit is set on the mounting frame. Typical roof curbing and flashing is shown in FIGURE 16. Refer to the roof mounting frame installation instructions for proper plenum construction and attachment.

B-Transitions

Optional supply/return transitions LASRT08/10 is available for use with the LCT 7.5 ton units and LASRT10/12 is available for the 8.5 and 10 ton units, utilizing optional C1CURB roof mounting frames. LCT 12.5 ton units will use LASRT15 with C1CURB roof mounting frame. Transition must be installed in the C1CURB mounting frame before mounting the unit to the frame. Refer to the manufacturer's instructions included with the transition for detailed installation procedures.

C-LOAD(M) Outdoor Air Dampers (all units)

LOAD(M) consists of a set of dampers which may be manually or motor (M) operated to allow up to 25 percent outside air into the system at all times (see FIGURE 17 and FIGURE 18). Either air damper can be installed in LCT units. Washable filter supplied with the outdoor air dampers can be cleaned with water and a mild detergent. It should be sprayed with Filter Handicoater when dry prior to re-installation.

D-Supply and Return Diffusers (all units)

Optional flush mount diffuser/return FD11 and extended mount diffuser/return RTD11 are available for use with all LCT units. Refer to manufacturer's instructions included with transition for detailed installation procedures.

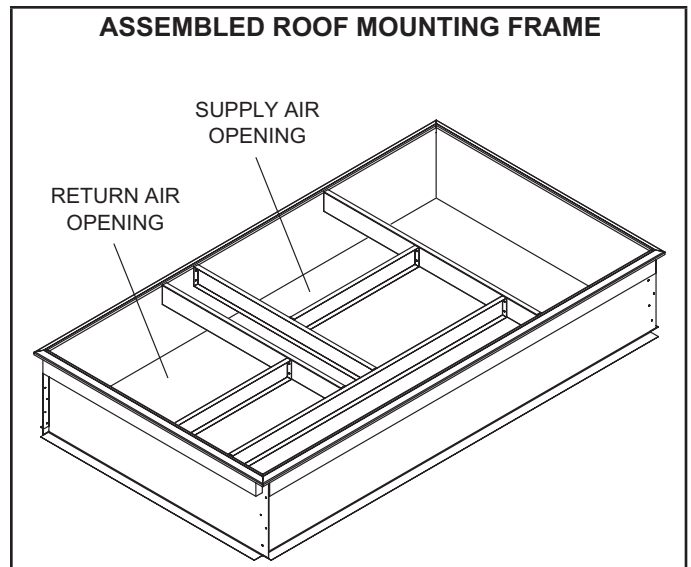

FIGURE 15

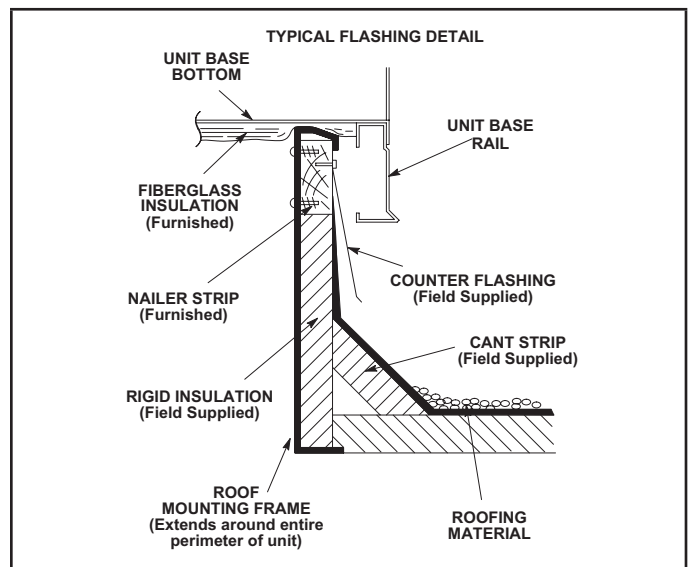

FIGURE 16

LAOAD(M) MOTORIZED OUTDOOR AIR DAMPER

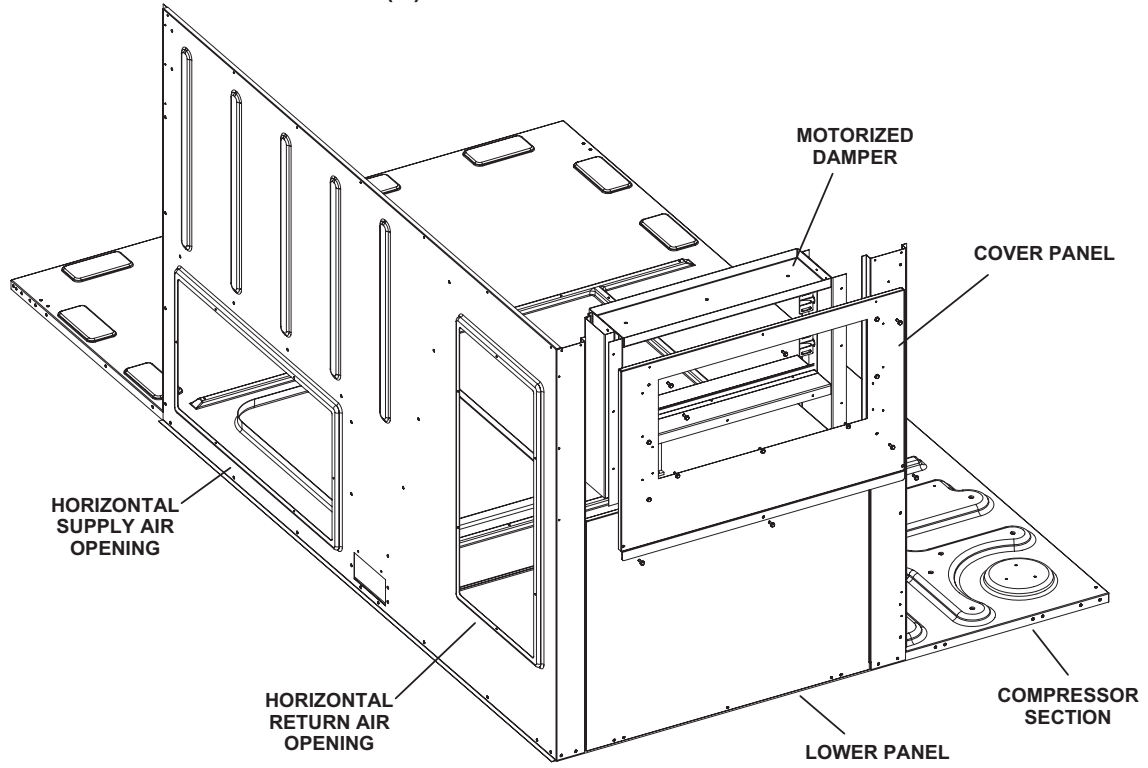

FIGURE 17

MANUAL OUTDOOR AIR DAMPER

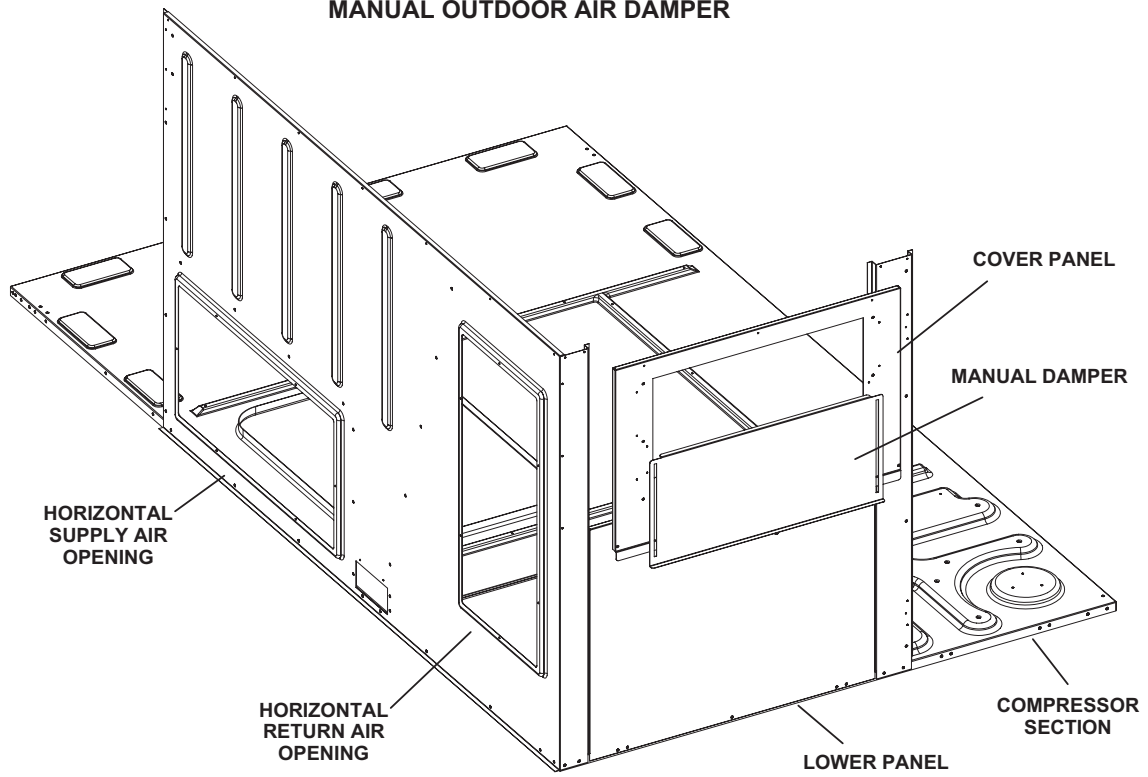

FIGURE 18

E-Economizer (all units) (Field or Factory Installed)

The optional E1ECON15 economizer can be used with downflow and horizontal air discharge applications. See FIGURE 21. The economizer uses outdoor air for free cooling when outdoor temperature and/or humidity is suitable. The economizer is controlled by the A55 Unit Controller.

Free Cooling Mode

The Unit Controller will allow free cooling in one of five modes. Each mode uses different combinations of sensors to determine outdoor air suitability. See TABLE 11 for modes. Temperature offset is the default free cooling mode.

NOTE - All free cooling modes of operation will modulate dampers to 55F (13C) supply / discharge air.

Unit Controller Settings

On early versions, switches are located on the Unit Controller to adjust settings. On newer versions, the display and keypad on the Unit Controller are used to navigate through menus to adjust settings. Some versions require a configuration ID be entered to enable the economizer. Refer to economizer installation instructions and Unit Controller installation and application manuals.

F-Gravity Exhaust Dampers

LAGEDH03/15 dampers (FIGURE 19) are used in downflow and horizontal air discharge applications. Horizontal gravity exhaust dampers are installed in the return air plenum. The dampers must be used any time an economizer or power exhaust fans are applied to LCT units. Gravity exhaust dampers allow exhaust air to be discharged from the system when an economizer and/or power exhaust is operating. Gravity exhaust dampers also prevent outdoor air infiltration during unit off cycle. See installation instructions for more detail.

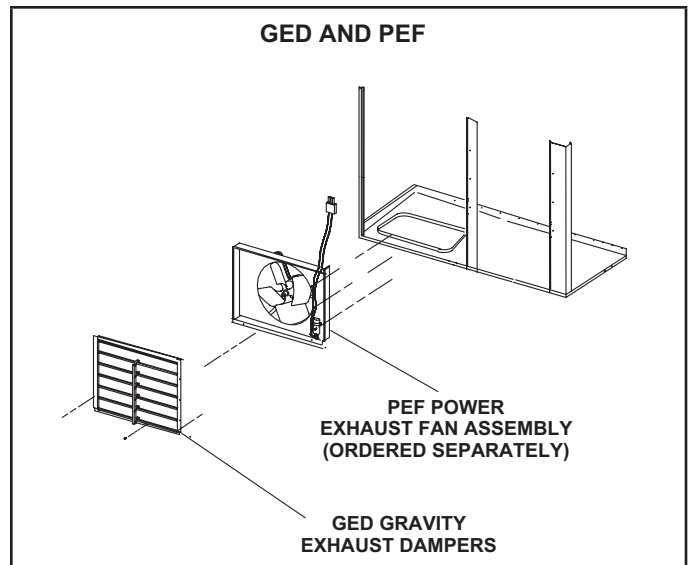

FIGURE 19

G-LAPEF Power Exhaust Fans

Power exhaust fans are used in downflow applications only. Fan requires optional down flow gravity exhaust dampers and LAREMD economizer. Power exhaust fans provide exhaust air pressure relief and also run when return air dampers are closed and supply air blowers are operating. FIGURE 20 shows the location of the LAPEF. See installation instructions for more detail.

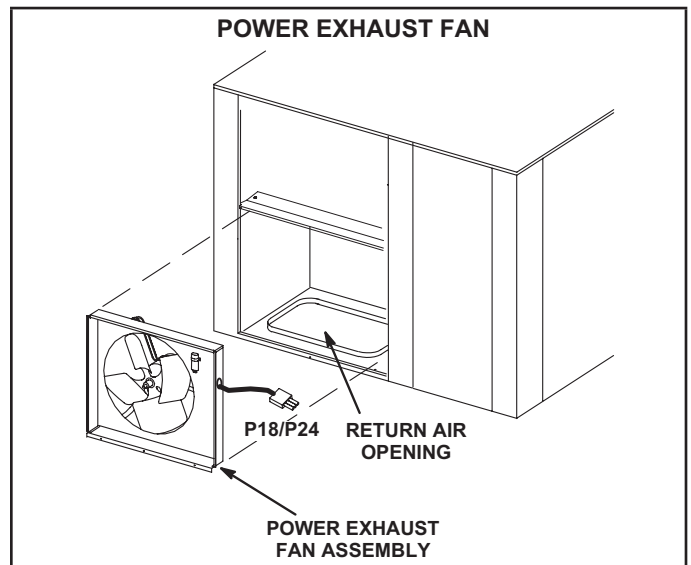

FIGURE 20

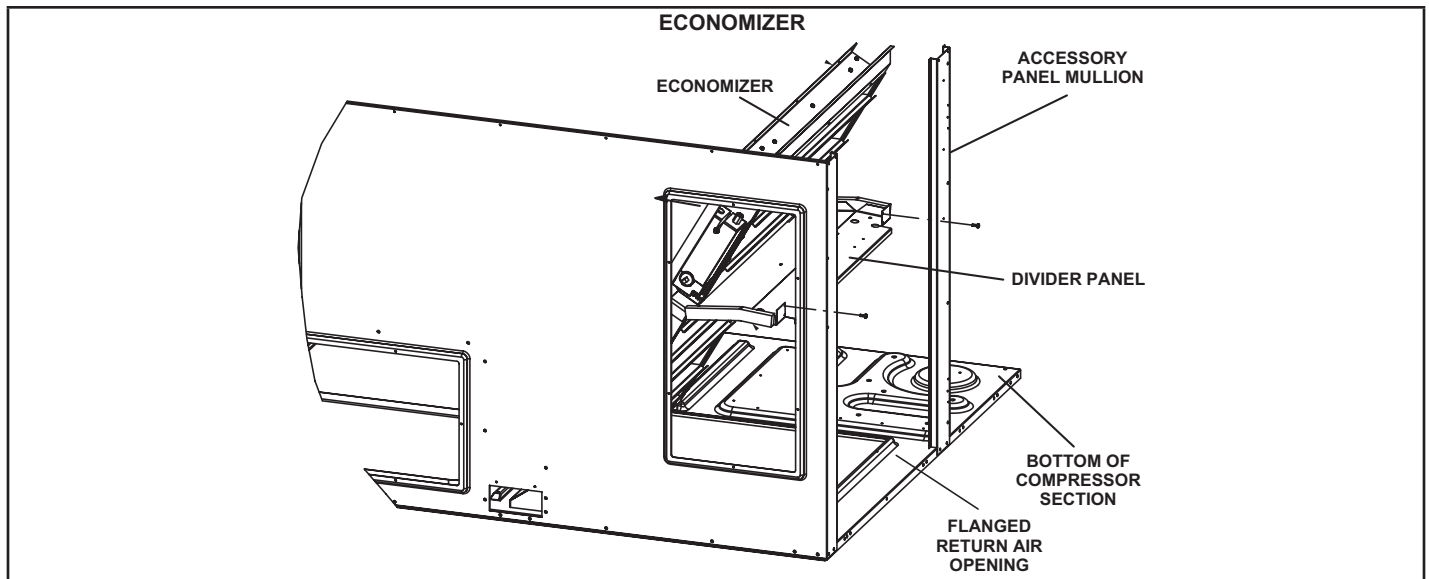

FIGURE 21

TABLE 15
ECONOMIZER MODES AND SETPOINT

Free Cooling Mode	Free Cooling Set Point	Field Provided Sensors	Dampers will modulate to 55°F (default, parameter 159) discharge air (RT6) when outdoor air is suitable:	Input Ranges
TEMP	OFFSET	None Needed	Outdoor air temperature (RT17) is less than return air temperature (RT16) by at least the OFFSET value (10°F default; parameter 161).	0-40°F
TEMP	OAT STPT	None Needed	Outdoor air temperature (RT17) is less than the OAT STPT value (75°F default; parameter 160).	41-75°F
Remote	Remote	Energy Management System**	Either of the TEMP modes can be used when a network OAS signal is provided by an energy management or building control system, via BACnet, LonTalk, or L Connection. The network can command OAS, NOT OAS, or AUTO. AUTO returns to local control of OAS, which is the selected TEMP mode.	NA
ENTH	DIFF OFFSET	(Two) C7400	Outdoor air enthalpy* (A7) is less than return air enthalpy (A62) by at least the OFFSET value (1mA = 2°F default; parameter 163).	0mA-4mA
ENTH	ODE STPT	C7400	Outdoor air enthalpy (A7) is less than free cooling setpoint (12mA = 75°F default, parameter 162).	12-19mA
GLOBAL	GLOBAL	24VAC Input Signal	Global input is energized by (P297-9). This setting is also used for outdoor air damper applications. Global input also brings on the blower. (This mode is NOT used when OAS signal is provided via network connection. GLO is only used when a 24VAC signal is used to energize the P297-9 GLO input.)	NA

*Enthalpy includes effects of both temperature and humidity.

**Energy management systems may require additional field-provided sensors; refer to manufacturer's instructions.

H-Control Systems

The A55 Unit Controller provides all control function for the rooftop unit. Default operation requires a standard room thermostat or direct digital controller (DDC). The A55 can also control the unit from a zone temperature sensor. The A55 Unit Controller is a network controller when daisy-chained to the L Connection® Network Control System. For ease of configuration, the A55 can be connected to a PC with Unit Controller PC software installed.

I-Smoke Detectors A17 and A64

Photoelectric smoke detectors are a factory installed option. The smoke detectors can be installed in the supply air section (A64), return air section (A17), or in both the supply and return air section. Wiring for the smoke detectors are shown on the temperature control section (C2) wiring diagram in back of this manual.

J-Blower Proving Switch S52

The blower proving switch monitors blower operation and locks out the unit in case of blower failure. The switch is N.O. and closes at 14" W.C. (34.9 Pa) The switch is mounted on the upper left hand corner of the blower deck. Wiring for the blower proving switch is shown on the temperature control section (C2) wiring diagram in back of this manual.

K-Dirty Filter Switch S27

The dirty filter switch senses static pressure increase indicating a dirty filter condition. The switch is N.O. and closes at 1" W.C. (248.6 Pa) The switch is mounted on the top filter channel corner. Wiring for the dirty filter switch is shown on the temperature control section (C2) wiring diagram in back of this manual.

L-Indoor Air Quality (CO2) Sensor A63

The indoor air quality sensor monitors CO2 levels and reports the levels to the A55 Unit Controller. The board adjusts the economizer dampers according to the CO2 levels. The sensor is mounted next to the indoor thermostat or in the return air duct. Refer to the indoor air quality sensor installation instructions for proper adjustment. Wiring for the indoor air quality switch is shown on the temperature control section (C2) wiring diagram in back of this manual.

M-Drain Pan Overflow Switch S149 (optional)

The overflow switch is used to interrupt cooling operation when excessive condensate collects in the drain pan. The N.O. overflow switch is controlled by K220 and DL46 relays, located in the unit control panel. When the overflow switch closes, 24VAC power is interrupted and after a five second delay unit compressors are de-energized. Once the condensate level drops below the set level, the switch will open. After a five-minute delay the compressor will be energized.

N-Factory Installed-Hot Gas Reheat (optional)

General

Hot Gas Reheat units provide a dehumidifying mode of operation. These units contain a reheat coil adjacent to and downstream of the evaporator coil. Reheat coil solenoid valve, L14, routes hot discharge gas from the compressor to the reheat coil. Return air pulled across the evaporator coil is cooled and dehumidified; the reheat coil adds heat to supply air. See FIGURE 22 for reheat refrigerant routing and FIGURE 23 for standard cooling refrigerant routing.

L14 Reheat Coil Solenoid Valve

When Unit Controller input (Unit Controller J298-5 or J299-8) indicates room conditions require dehumidification, L14 reheat valve is energized (Unit Controller P269-3) and refrigerant is routed to the reheat coil.

Reheat Setpoint

Reheat is factory-set to energize when indoor relative humidity rises above 60% (default). The reheat setpoint can be adjusted by changing Unit Controller Settings - Control menu. A setting of 100% will operate reheat from an energy management system digital output. The reheat setpoint can also be adjusted using an optional Network Control Panel (NCP). Reheat will terminate when the indoor relative humidity falls 3% (57% default) or the digital output de-energizes. The reheat deadband can be adjusted at Settings - Control menu.

Check-Out

Test Hot Gas Reheat operation using the following procedure.

- 1 - Make sure reheat is wired as shown in wiring section.
- 2 - Make sure unit is in local thermostat mode.
- 3 - Select Unit Controller Service - Test.

The blower and compressor 1 (reheat) should be operating. Reheat mode will be appear on the Unit Controller display.

- 4 - Deselect Unit Controller Service - Test.

Compressor 1 (reheat) and blower should de-energize.

Default Reheat Operation

TABLE 16

Reheat Operation - Two Cooling Stages - Default

T'stat & Humidity Demands	Operation
Reheat Only	Compressor 1 Full Load Reheat ON Blower Low
Reheat & Y1	Compressor 1 & 2 Full Load Reheat ON Blower High
Reheat & Y1 & Y2	Compressor 1 & 2 Full Load, Reheat OFF Blower High

*If there is no reheat demand and outdoor air is suitable, free cooling will operate.

**If there is no reheat demand and outdoor air is suitable, free cooling and compressor 1 will operate.

TABLE 17

Reheat Operation - Three Cooling Stages - Default

T'stat & Humidity Demands	Operation
Reheat Only	Compressor 1 Full Load, Reheat ON, Blower Low
Reheat & Y1	Compressor 1 & 2 Full Load, Reheat ON, Blower Medium
Reheat & Y1, Y2	Compressor 1 & 2 Full Load, Reheat ON, Blower High
Reheat & Y1, Y2, Y3	Compressor 1 & 2 Full Load, No Reheat OFF, Blower High

*If there is no reheat demand and outdoor air is suitable, free cooling will operate.

**If there is no reheat demand and outdoor air is suitable, free cooling and compressor 1 will operate.

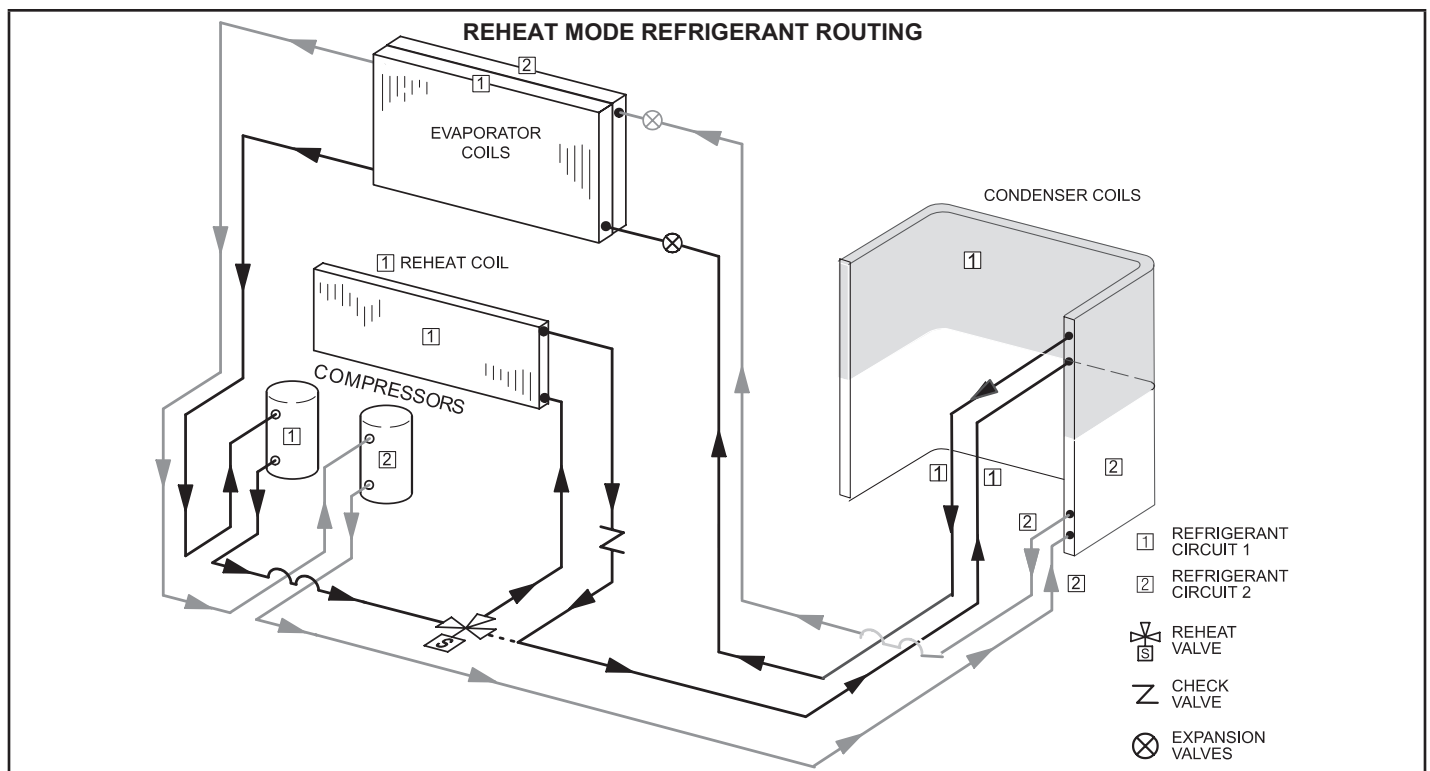

FIGURE 22

COOLING MODE REFRIGERANT ROUTING

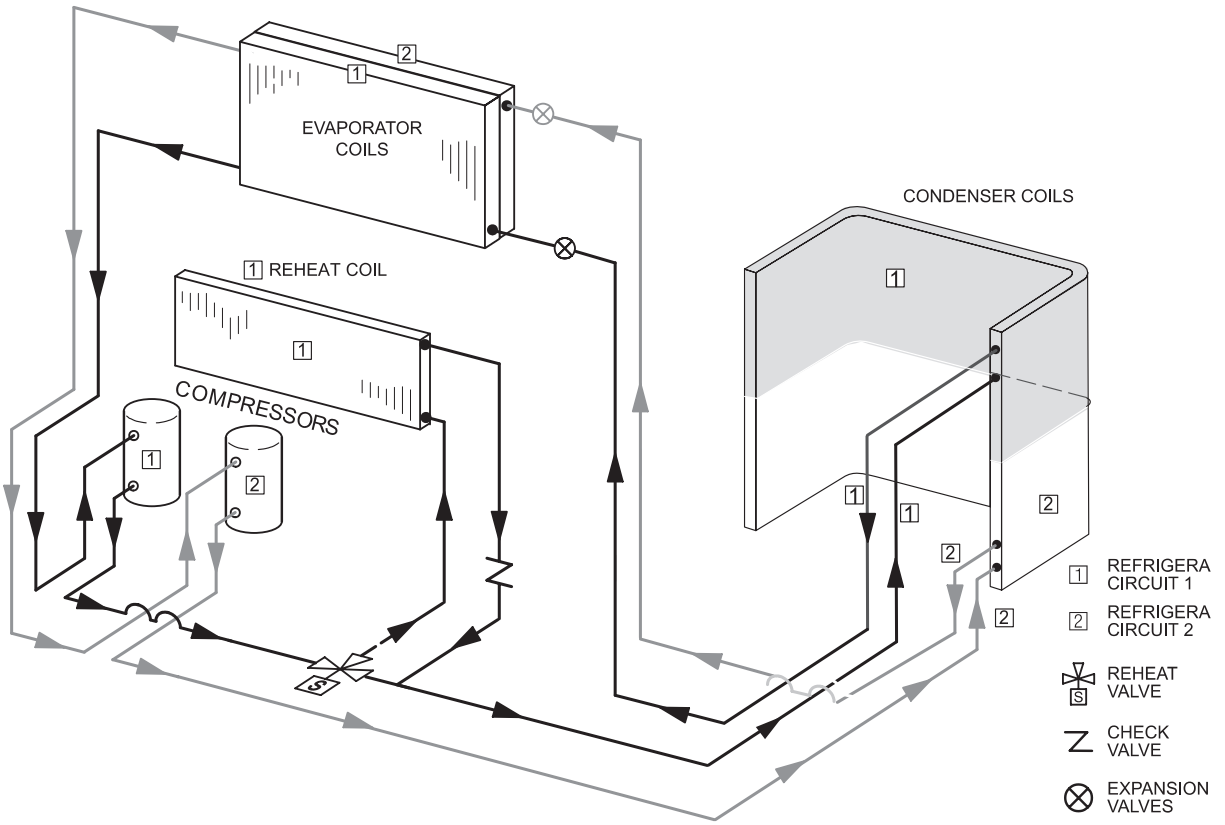

FIGURE 23

VII-Direct Drive Supply Air Inverter

If a test and balance contractor has not commissioned the unit, use this section to set supply air CFM.

A-Set Blower Speed

- 1 - Use TABLE 14 to fill in field-provided, design specified blower CFM.

TABLE 18

Blower CFM Design Specifications

Blower Speed	Design Specified CFM
Heating	
Cooling High	
Cooling Medium	
Cooling Low	
Ventilation	

- 2 - Use the following menu to enter the blower design specified CFM into the Unit Controller. Don't press "SAVE" until all CFM are entered. Refer to the Unit Controller manual provided with unit.

SETUP > TEST & BALANCE > BLOWER

- 3 - Once all four speeds are entered, the target (highest of the heating and cooling settings) CFM and default RPM will be displayed.

Note - When units are not equipped with heat, the Blower Heat speed will not be displayed. Blower Cooling High will be the first blower speed to appear.

- 4 - Measure the static pressure as shown in the Blower Start-Up section. Use the static pressure, target CFM and blower tables to determine the RPM needed. Values in the blower table reflect the static pressures taken in locations shown in FIGURE 10.
- 5 - Enter the RPM and repeat the previous step until the design CFM is reached.
- 6 - Press SAVE followed by MAIN MENU.

Note - Once the CFM settings are saved, the Unit Controller will set all other blower CFM.

B-Set Damper Minimum Position

To maintain required minimum ventilation air volumes when the unit is in the occupied mode, two minimum damper positions must be set. The Unit Controller will open the dampers to "Min OCP Blwr Low" when blower CFM is BELOW a "midpoint" CFM. The Unit Controller will open the damper to "Min OCP Blwr High" when blower CFM is at or ABOVE the "midpoint" CFM.

The Unit Controller will calculate the "midpoint" CFM.

Set Minimum Position 1

Use the following menu in the Unit Controller to set "Min OCP Blwr Low" for the blower CFM below the "midpoint" CFM. When navigating into this menu, the Unit Controller will bring on the corresponding blower speed and allow damper position adjustment.

SETTINGS > RTU Options > EDIT PARAMETER > ENTER DATA ID - 9 > MIN DAMPER LOW BLOWER = X.X %

Measure the intake air CFM. If the CFM is lower than the design specified CFM for ventilation air, use the Unit Controller to increase the damper percent open. If the CFM is higher than specified, decrease the damper percent open.

Note - Intake air CFM can also be determined using the outdoor air temperature, return air temperature and mixed air temperature. Refer to the economizer or outdoor air damper installation instructions.

Set Minimum Position 2

Use the same menu in the Unit Controller to set "Min OCP Blwr High" for the blower CFM above the "midpoint" CFM. When navigating into this menu, the Unit Controller will bring on the corresponding blower speed and allow damper position adjustment.

SETTINGS > RTU OPTIONS > DAMPER > MIN DAMPER POSITION BLOWER ON HIGH = X.X %

Measure the intake air CFM. If the CFM is lower than the design specified CFM for ventilation air, use the Unit Controller to increase the damper percent open. If the CFM is higher than specified, decrease the damper percent open.

Note - Intake air CFM can also be determined using the outdoor air temperature, return air temperature and mixed air temperature. Refer to the economizer or outdoor air damper installation instructions.

TABLE 19

Electric Heat Minimum CFM

LCT Unit	Heat Size (kW)	Airflow CFM
092, 102	7.5	1750
092, 102	15, 22.5, 30, 45	2750
120, 150	15, 22.5, 30, 45	2750
120, 150	60	3500

VIII-Staged Supply Air Operation

This is a summary of cooling operation for both belt and direct drive blowers.

Note - During a dehumidification demand the blower operates at the highest speed. Free cooling is locked-out during reheat operation. Refer to Hot Gas Reheat start-up and operation section for details.

A-Two-Stage Thermostat

1-Economizer With Outdoor Air Suitable

Y1 Demand -

Compressors Off
Blower Cooling Low
Dampers modulate to maintain 55° supply air

Y2 Demand -

Compressors Off
Blower Cooling High
Dampers Modulate to maintain 55° supply air

Note - If dampers are at maximum open for three minutes, compressor 1 is energized and blower stays on cooling high.

2-No Economizer or Outdoor Air Not Suitable

Y1 Demand -

Compressor 1 On
Blower Cooling Low

Y2 Demand -

Compressor 1 and 2 On
Blower Cooling High

B-Three-Stage Thermostat OR Zone Sensor

1-Economizer With Outdoor Air Suitable

Y1 Demand -

Compressors Off
Blower Cooling Low
Dampers modulate to maintain 55° supply air

Y2 Demand -

Compressors Off
Blower Cooling High
Dampers Modulate to maintain 55° supply air

Note - If dampers are at maximum open for three minutes, compressor 1 is energized and blower stays on cooling high. Economizer stays at maximum position after compressors are energized.

Y3 Demand -

Compressors 1 and 2 On
Blower Cooling High
Dampers Maximum Open

2-No Economizer or Outdoor Air Not Suitable

Y1 Demand -

Compressor 1 On Part Load
Blower Cooling Low

Y2 Demand -

Compressor 1 On Part Load Compressor 2 On.
Blower Cooling Medium

Y3 Demand -

Compressors 1 and 2 On
Blower Cooling High

IX-MAINTENANCE

The unit should be inspected once a year by a qualified service technician.

⚠ WARNING	
	Electric shock hazard. Can cause injury or death. Before attempting to perform any service or maintenance, turn the electrical power to unit OFF at disconnect switch(es). Unit may have multiple power supplies.

⚠ IMPORTANT	
Label all wires prior to disconnection when servicing controls. Wiring errors can cause improper and dangerous operation. Verify proper operation after servicing.	

⚠ WARNING	
Any service personnel installing, decommissioning, or performing maintenance on the unit must be properly trained with A2L refrigerants	

Prior to beginning work on systems containing refrigerant to ensure the risk of ignition is minimized:

- All work shall be undertaken under a controlled procedure so as to minimize the risk of a flammable gas or vapor being present while the work is being performed.
- The area shall be checked with an appropriate refrigerant detector prior to and during work, to ensure the technician is aware of potentially toxic or flammable atmospheres. Ensure that the leak detection equipment being used is suitable for use with all applicable refrigerants, i. e. non-sparking, adequately sealed or intrinsically safe.
- If any hot work is to be conducted on the refrigerating equipment or any associated parts, the appropriate fire extinguishing equipment shall be available to hand. Have a dry powder or CO2 fire extinguisher adjacent to the charging area.

- No person carrying out work in relation to a refrigerating system which involves exposing any pipe work shall use any sources of ignition in such a manner that it may lead to the risk of fire or explosion. All possible ignition sources, including cigarette smoking, should be kept sufficiently far away from the site of installation, repairing, removing and disposal, during which refrigerant can possibly be released to the surrounding space. Prior to work taking place, the area around the equipment is to be surveyed to make sure that there are no flammable hazards or ignition risks. "No Smoking" signs shall be displayed.
- Ensure that the area is in the open or that it is adequately ventilated before breaking into the system or conducting any hot work.

A degree of ventilation shall continue during the period that the work is carried out. The ventilation should safely disperse any released refrigerant and preferably expel it externally into the atmosphere.

- Where electrical components are being changed, service technicians shall be fit for the purpose and to the correct specification. At all times the manufacturer's maintenance and service guidelines shall be followed. If in doubt, consult the manufacturer's technical department for assistance. The following checks shall be applied to installations using flammable refrigerants as applicable:
 - 1 - The actual refrigerant charge is in accordance with the room size within which the refrigerant containing parts are installed.
 - 2 - The ventilation machinery and outlets are operating adequately and are not obstructed.
 - 3 - If an indirect refrigerating circuit is being used, the secondary circuit shall be checked for the presence of refrigerant.
 - 4 - Markings on the equipment should be visible and legible. Markings and signs that are illegible shall be corrected.
 - 5 - Refrigerating pipes or components are installed in a position where they are unlikely to be exposed to any substance which may corrode refrigerant containing components, unless the components are constructed of materials which are inherently resistant to being corroded or are suitably protected against being so corroded. For systems containing refrigerant all repair and maintenance to electrical components shall include initial safety checks and component inspection procedures such as that capacitors are discharged in a safe manner to avoid possibility of sparking, that no live electrical components and wiring are exposed while charging, recovering, or purging the system, and that there is continuity of earth bonding. If a fault exists that could compromise safety, then no electrical supply shall be connected to the circuit until it is satisfactorily dealt with. If the fault cannot

be corrected immediately but it is necessary to continue operation, an adequate temporary solution shall be used that is reported to the owner of the equipment, so all parties are advised.

NOTE - Sealed electrical components shall be replaced, not repaired.

NOTE - Intrinsically safe components must be replaced, not repaired.

- Under no circumstances shall potential sources of ignition be used in the searching for or detection of refrigerant leaks. A halide torch (or any other detector using a naked flame) shall not be used. Electronic leak detectors may be used to detect refrigerant leaks but, in the case of flammable refrigerants, the sensitivity may not be adequate, or may need re-calibration. (Detection equipment shall be calibrated in a refrigerant-free area.) Ensure that the detector is not a potential source of ignition and is suitable for the refrigerant used. Leak detection equipment shall be set at a percentage of the LFL of the refrigerant and shall be calibrated to the refrigerant employed, and the appropriate percentage of gas (25 % maximum) is confirmed. Leak detection fluids are also suitable for use with most refrigerants but the use of detergents containing chlorine shall be avoided as the chlorine may react with the refrigerant and corrode the copper pipe-work. If a leak is suspected, all naked flames shall be removed/extinguished. If a leakage of refrigerant is found which requires brazing, all of the refrigerant shall be recovered from the system, or isolated (by means of shut off valves) in a part of the system remote from the leak.
- When breaking into the refrigerant circuit to make repairs – or for any other purpose – conventional procedures shall be used. However, for flammable refrigerants it is important that best practice be followed, since flammability is a consideration. The following procedure shall be adhered to:
 - a. Safely remove refrigerant following local and national regulations,
 - b. Evacuate the circuit,
 - c. Purge the circuit with inert gas,
 - d. Evacuate,
 - e. Purge with inert gas,
 - f. Open the circuit.
- The refrigerant charge shall be recovered into the correct recovery cylinders if venting is not allowed by local and national codes. For appliances containing flammable refrigerants, the system shall be purged with oxygen-free nitrogen to render the appliance safe for flammable refrigerants. This process might need to be repeated several times. Compressed air or oxygen shall not be used for purging refrigerant systems. Refrigerant purging shall be achieved by breaking the vacuum in the system with oxygen-free nitrogen and continuing to fill until the working pressure is achieved, then venting to atmosphere, and finally pulling down to a vacuum. This process shall be repeated until no refrigerant is within the system. When the final oxygen-free nitrogen charge is used, the system shall be vented down to atmospheric pressure to enable work to take place. Ensure that the outlet for the vacuum pump is not close to any potential ignition sources and that ventilation is available.

X-Wiring Diagrams and Sequence of Operation

ELECTRIC HEAT FOR LCT092-150 UNITS

J/P	JACK/PLUG DESCRIPTION
7	ELECTRIC HEAT SUB BASE KIT
Z71	HEATING SENSORS STG 1

KEY	DESCRIPTION
A55	PANEL MAIN
F3	FUSE, ELECTRIC HEAT 1
F4	FUSE, UNIT
F42	FUSE, ELECTRIC HEAT 2
F43	FUSE, ELECTRIC HEAT 3,4
F44	FUSE, ELECTRIC HEAT 5
F61	FUSE, UNIT - SOCR
HE1	ELEMENT, ELECTRIC HEAT 1
HE2	ELEMENT, ELECTRIC HEAT 2
HE3	ELEMENT, ELECTRIC HEAT 3
HE4	ELEMENT, ELECTRIC HEAT 4
HE5	ELEMENT, ELECTRIC HEAT 5
HE6	ELEMENT, ELECTRIC HEAT 6
K15-1	CONTACTOR, ELECTRIC HEAT 1, 2
K16-1	CONTACTOR, ELECTRIC HEAT 3, 4
S15	SWITCH, LIMIT PRIMARY ELECTRIC HEAT
S19	THERMOSTAT, ELECTRIC HEAT LIMIT
S20	SWITCH, LIMIT SECONDARY ELEC. HEAT 1 (NO RESET)
S157	SWITCH, LIMIT SECONDARY ELEC. HEAT 2 (NO RESET)
S158	SWITCH, LIMIT SECONDARY ELEC. HEAT 3 (NO RESET)
S159	SWITCH, LIMIT SECONDARY ELEC. HEAT 4 (NO RESET)
TB2	TERMINAL STRIP, UNIT
TB3	TERMINAL STRIP, ELECTRIC HEAT

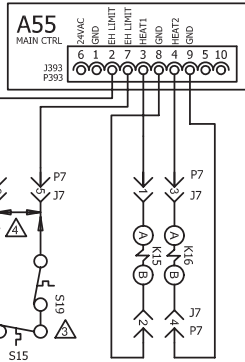

G, J VOLT UNITS

KW	HE1	HE2	HE3	HE4
7.5	7.5			
15	15			
22.5	15		7.5	
30	15		15	
45	15		15	15
60	15	15	15	15

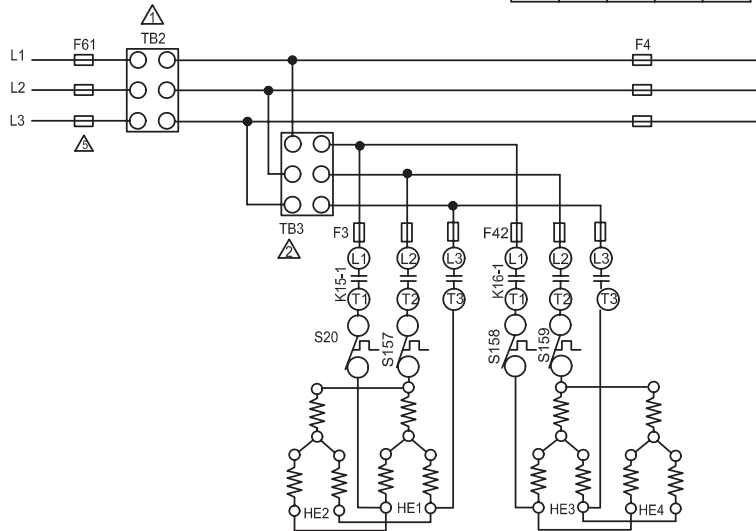

- ▲ TB2, S48 OR CB10 MAY BE USED
- ▲ TB3 IS USED ON SOME UNITS
- ▲ S19 IS USED ON HEAT PUMP APPLICATIONS ONLY
- ▲ REMOVE JUMPER PLUG WHEN FIELD INSTALLING ELECTRIC HEAT
- ▲ F61 USED ON UNITS WITH SOCR OPTION

— DENOTES OPTIONAL COMPONENTS

2021/09	WIRING DIAGRAM	9/21
	538121-02	
HEATING-ELECTRIC		
7.5, 15, 22.5, 30, 45, 60 - G, J		
SECTION A		REV. 0
Supersedes	New Form No.	
538121-01	538121-02	

ELECTRIC HEAT FOR LCT092-150 UNITS

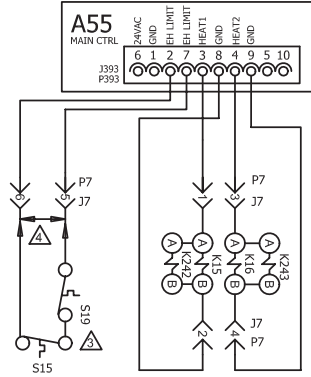

KEY	DESCRIPTION
A55	PANEL MAIN
F3	FUSE, ELECTRIC HEAT 1
F4	FUSE, UNIT
F42	FUSE, ELECTRIC HEAT 2
F43	FUSE, ELECTRIC HEAT 3, 4
F44	FUSE, ELECTRIC HEAT 5
F61	FUSE, UNIT - SCCR
HE1	ELEMENT, ELECTRIC HEAT 1
HE2	ELEMENT, ELECTRIC HEAT 2
HE3	ELEMENT, ELECTRIC HEAT 3
HE4	ELEMENT, ELECTRIC HEAT 4
HE5	ELEMENT, ELECTRIC HEAT 5
HE6	ELEMENT, ELECTRIC HEAT 6
K15-1	CONTACTOR, ELECTRIC HEAT 1, 2
K16-1	CONTACTOR, ELECTRIC HEAT 3, 4
K242-1	CONTACTOR, ELECTRIC HEAT 1
K243-1	CONTACTOR, ELECTRIC HEAT 2
S15	SWITCH, LIMIT PRIMARY ELECTRIC HEAT
S19	THERMOSTAT, ELECTRIC HEAT LIMIT
S20	SWITCH, LIMIT SECONDARY ELEC, HEAT 1 (NO RESET)
S157	SWITCH, LIMIT SECONDARY ELEC, HEAT 2 (NO RESET)
S158	SWITCH, LIMIT SECONDARY ELEC, HEAT 3 (NO RESET)
S159	SWITCH, LIMIT SECONDARY ELEC, HEAT 4 (NO RESET)
S160	SWITCH, LIMIT SECONDARY ELEC, HEAT 5 (NO RESET)
S161	SWITCH, LIMIT SECONDARY ELEC, HEAT 6 (NO RESET)
TB2	TERMINAL STRIP, UNIT
TB3	TERMINAL STRIP, ELECTRIC HEAT

J/P	JACK/PLUG DESCRIPTION
7	ELECTRIC HEAT SUB BASE KIT

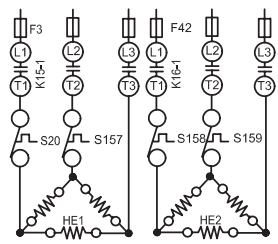
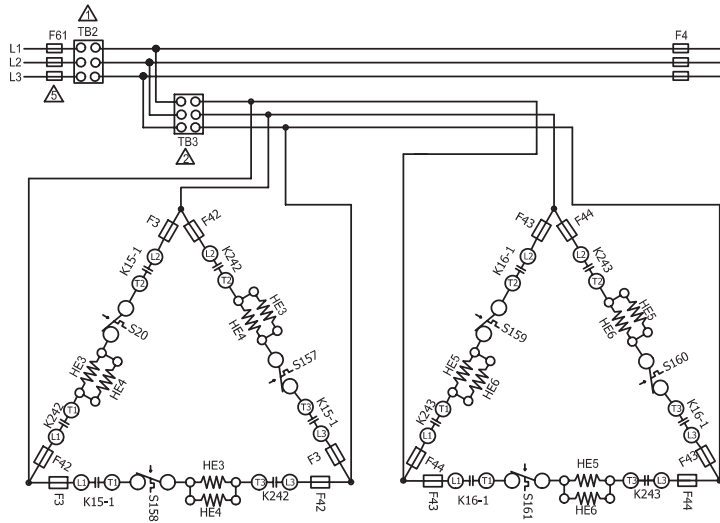

- △ TB2, S48 OR CB10 MAY BE USED
- △ TB3 IS USED ON SOME UNITS
- △ S19 IS USED ON HEAT PUMP APPLICATIONS ONLY
- △ REMOVE JUMPER PLUG WHEN FIELD INSTALLING ELECTRIC HEAT
- △ F61 USED ON UNITS WITH SCCR OPTION
- DENOTES OPTIONAL COMPONENTS

KW	HE1	HE2	HE3	HE4	HE5	HE6
7.5	7.5					
15	15					
22.5	15	7.5				
30	15	15				
45	15			15	15	
60			15	15	15	15

2020/10
WIRING DIAGRAM
10/20

538120-01

HEATING - ELECTRIC

ELECTRIC HEAT

7.5, 15, 22.5, 30, 45, 60 - Y

SECTION A
REV 0

Supersedes
New Form No.

538120-01

SEQUENCE OF OPERATION EHA7.5, 15, 22.5, 30, 45, 60 kW - G, J and Y

G and J Voltage

- 1 - Terminal strip TB3 is energized when the unit disconnect closes. TB3 supplies line voltage to electric heat elements HE1, HE2, HE3 and HE4. HE1 and HE2 elements are protected by F3 and HE3 and HE4 elements are protected by fuse F42.

First Stage Heat:

- 2 - Heating demand initiates at W1 in the thermostat.
- 3 - 24VAC is routed through A55 Unit Controller. After A55 proves N.C. primary limit S15, contactor K15 is energized.
- 4 - N.O. K15-1 contacts close energizing HE1 and HE2.

Second Stage Heat:

- 5 - With first stage heat operating, an additional heating demand initiates W2 in the thermostat.
- 6 - A second stage heating demand is received by A55 control module.
- 7 - A55 energizes contactor K16.
- 8 - N.O. K16-1 contacts close energizing HE3 and HE4.

Y Voltage

- 1 - Terminal strip TB3 is energized when the unit disconnect closes. TB3 supplies line voltage to electric heat elements HE1, HE2, HE3, HE4, HE5 and HE6.

First Stage Heat:

- 2 - 7.5 - 45 KW - Heating demand initiates at W1 in the thermostat.

- 3 - 24VAC is routed through A55 Unit Controller. After A55 proves N.C. primary limit S15 and S157, contactor K15 is energized.

- 4 - N.O. K15 contacts close energizing HE1.

- 5 - **60KW** - Heating demand initiates at W1 in the thermostat.

- 6 - 24VAC is routed through A55 Unit Controller. After A55 proves N.C. primary limit S157, contactor K242 is energized.

- 7 - N.O. K242 contacts close energizing HE3 and HE4.

Second Stage Heat:

- 8 - **22.5 - 45 KW** - With first stage heat operating, an additional heating demand initiates W2 in the thermostat.

- 9 - A second stage heating demand is received by A55 control module. After A55 proves N.C. primary limit S58 and S159, contactor K16 is energized.

- 10 - N.O. K16 contacts close energizing HE2 (22.5 and 30KW units only) and HE5 and HE6 (45 KW units only).

- 11 - **60KW** - With first stage heat operating, an additional heating demand initiates W2 in the thermostat.

- 12 - A second stage heating demand is received by A55 control module. After A55 proves N.C. primary limit S160 and S161, contactor K16 is energized.

- 13 - N.O. K16 contacts close energizing HE5 and HE6.

ELECTRONIC OR ELECTROMECHANICAL THERMOSTAT

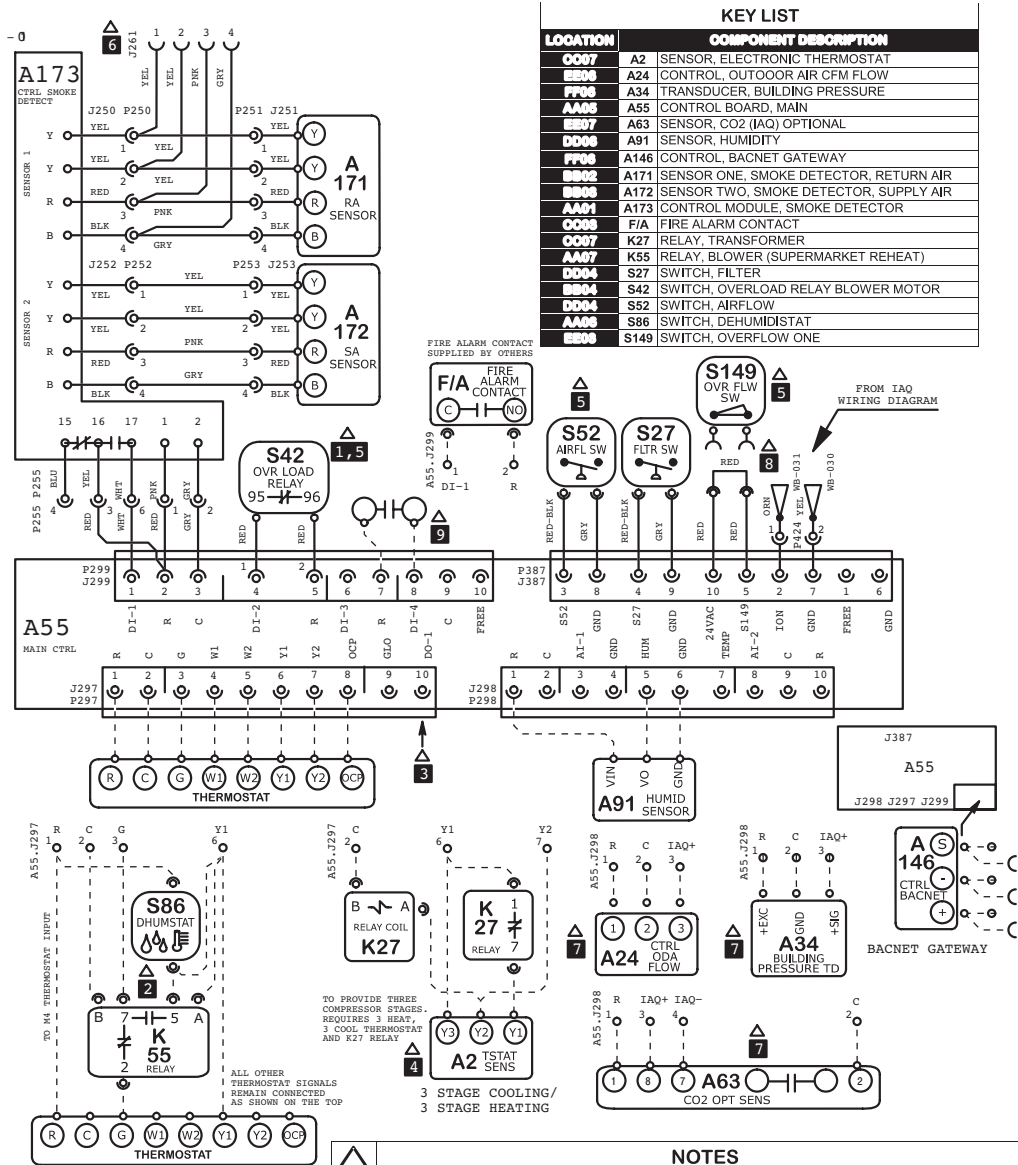

KEY LIST		LOCATION	COMPONENT DESCRIPTION
0007	A2	SENSOR	ELECTRONIC THERMOSTAT
0006	A24	CONTROL	OUTDOOR AIR CFM FLOW
0006	A34	TRANSDUCER	BUILDING PRESSURE
AA05	A55	CONTROL BOARD	MAIN
0007	A63	SENSOR	CO2 (IAQ) OPTIONAL
0006	A91	SENSOR	HUMIDITY
0006	A146	CONTROL	BACNET GATEWAY
0002	A171	SENSOR ONE	SMOKE DETECTOR, RETURN AIR
0002	A172	SENSOR TWO	SMOKE DETECTOR, SUPPLY AIR
AA01	A173	CONTROL MODULE	SMOKE DETECTOR
0006	F/A	FIRE ALARM CONTACT	
0007	K27	RELAY	TRANSFORMER
AA07	K55	RELAY	BLOWER (SUPERMARKET REHEAT)
0004	S27	SWITCH	FILTER
0004	S42	SWITCH	OVERLOAD RELAY BLOWER MOTOR
0004	S52	SWITCH	AIRFLOW
AA09	S86	SWITCH	DEHUMIDISTAT
0006	S149	SWITCH	OVERFLOW ONE

- NOTES**
- 1 FOR MOTORS WITH S42 EXTERNAL OVERLOAD LESS INVERTER, SEE INVERTER WITH BY PASS FOR S42 HOOK UP
 - 2 USE S86 DEHUMIDISTAT AND K55 FOR OPTIONAL SUPERMARKET REHEAT SCHEME, PRODIGY PARAMETERS NEED TO BE MODIFIED UNDER THE SETTINGS MENU OR VIA UC SOFTWARE FOR SIMULTANEOUS HEATING AND COOLING
 - 3 P297-10 (SR) IS SERVICE RELAY OUTPUT (24VAC) IF USED CONNECT TO AN INDICATOR LIGHT
 - 4 THERMOSTAT HOOKUP FOR PROGRAMMABLE CONFIGURATION OF THE BOARD (A55)
 - 5 PRODIGY SETTINGS MUST BE MODIFIED WHEN S42, S52, S149 ARE INSTALLED
 - 6 CONNECT P252 OF A172 SENSOR TO J261 ON SUPPLY AIR SMOKE DETECTOR ONLY
 - 7 FROM A63, A34 & A24, ONLY ONE CAN BE USED AT A TIME
 - 8 REMOVE JUMPER TO INSTALL S149
 - 9 EXTERNAL HUMIDITROL CONTACTS

Model: LC, LG, LH, LD Series RTU
 Thermostat
 Voltage: All Voltages
 Supersedes: N/A Form No: 538078-01 Rev: 1

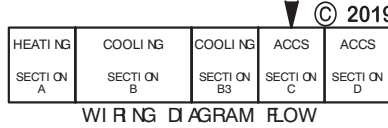

ECONOMIZER

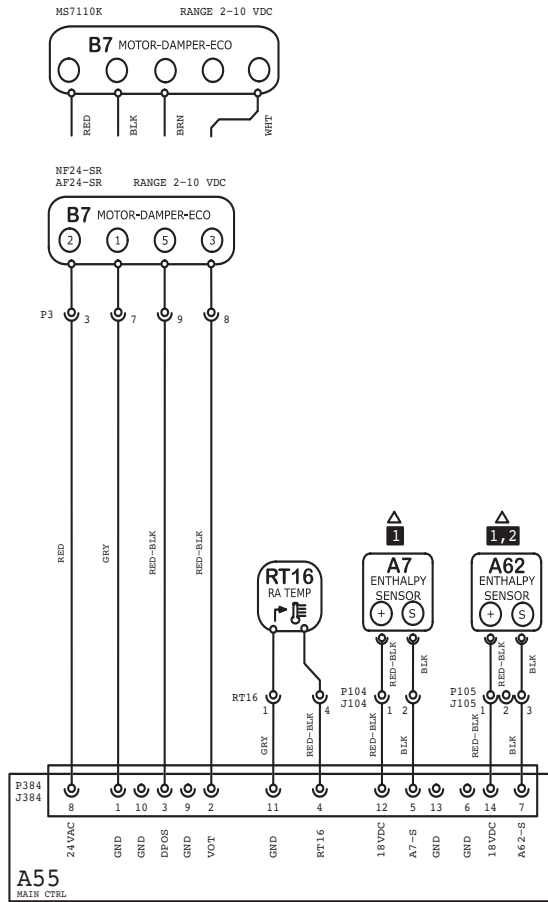

NOTES	
1	A7 AND A62 NOT USED FOR SENSIBLE TEMPERATURE CONTROL
2	FOR UNIT DIFFERENTIAL ENTHALPY CONTROL, ADD A62 RETURN AIR ENTHALPY SENSOR

KEY LIST	
LOCATION	COMPONENT DESCRIPTION
CC05	A7 SENSOR, SOLID STATE ENTHALPY
AA05	A55 CONTROL BOARD, MAIN
DD05	A62 SENSOR, ENTHALPY INDOOR
BB02	B7 MOTOR, DAMPER ECONOMIZER
CC05	RT16 SENSOR, RETURN AIR TEMP

Model: LC, LG, LH, LD Series RTU
Economizer & Motorized OAD

Voltage: All Voltages

Supersedes: N/A

Form No: 538072-01 Rev: 1

© 2019

HTG SEC A	CLG SEC B	OLG SEC B3	ACCS SEC C	ACCS SEC D
-----------------	-----------------	------------------	------------------	------------------

WI R I N G D I A G R A M F L O W

538364-01

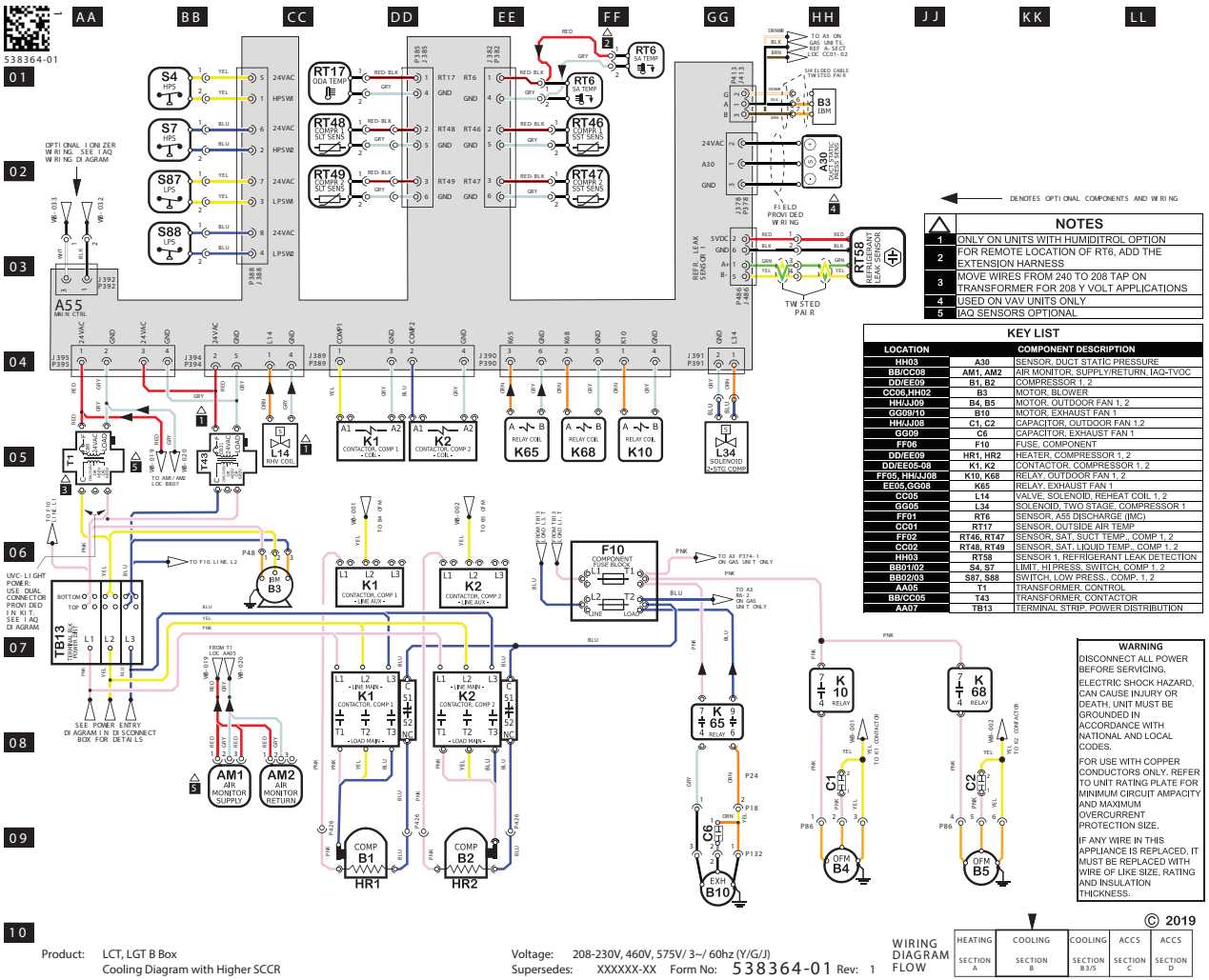

10 x 12 CUT SIZE

REV	EC NO.	DATE	BY	APVD	REVISION NOTE
—	CN-012081C	04-29-2024	FEP	MCF	ORIGINATED AT PD&R CARROLLTON, TX
001	CN-012081W	10-07-2024	FEP	FXY	UPDATED P18 CONNECTORS FROM 3 & 4 TO 1 & 2

FIGURE 24

LCT092H-150H SEQUENCE OF OPERATION

Power:

- 1 - Line voltage through the S48 unit disconnect, TB2 terminal block, or CB10 circuit breaker energizes the T1 transformer. T1 provides 24VAC power to A55 Unit Controller which provides 24VAC to the unit cooling, heating and blower controls.
- 2 - Line voltage is also routed to compressor crankcase heaters, compressor contactors, the blower motor, condenser fan relays and exhaust fan relays.

Blower Operation:

- 3 - The A55 Unit Controller module receives a demand from thermostat terminal G.
- 4 - B3 receives the pre-set blower setting through MODUS.

Economizer Operation:

- 5 - A55 receives a demand and energizes exhaust fan relay K65 with 24VAC at 50% outside air damper open (adjustable).
- 6 - N.O. K65-1 and N.O. K65-2 both close, energizing exhaust fan motor B10.

1st Stage Cooling (compressor B1)

- 7 - A55 receives a Y1 thermostat demand.
- 8 - After A55 proves N.C. low pressure switch S87, RT46 reading above freeze point and N.C. high pressure switch S4, compressor contactor K1 is energized.
- 9 - N.O. contacts K1-1 close energizing compressor B1. Crankcase heater HR1 is de-energized.
- 10 - At the same time, A55 energizes condenser fan relays K10 and K68.
- 11 - N.O. contacts K10-1 close energizing condenser fan B4 and N.O. contacts K68-1 close energizing condenser fan B5.

2nd Stage Cooling (compressor B2 is energized)

- 12 - A55 receives a Y2 thermostat demand.
- 13 - After A55 proves N.C. low pressure switch S88, RT47 reading above freeze point, and N.C. high pressure switch S7, compressor contactor K2 is energized.
- 14 - N.O. contacts K2-1 close energizing compressor B2. Crankcase heater HR2 is de-energized.

3rd Stage Cooling (compressor B1 in full load and compressor 2 is energized)

- 15 - A55 receives a Y3 thermostat demand (Y1 + Y2 thermostat inputs).
- 16 - A55 sends 24VAC to B1 compressor solenoid (L34), B1 compressor runs at full load.

DIRECT DRIVE BLOWER SEQUENCE OF OPERATION / TROUBLESHOOTING

Blower Operation:

- 1 - Line voltage is routed to B3 blower motor through TB2 terminal strip, TB13 terminal strip and J/P48 terminals 1, 2 and 3.
- 2 - B3 blower motor runs internal diagnostics to check for proper temperature, voltage, etc. (KL2-2 and -3). This process takes approximately 10 seconds. Refer to the Failure Handling/Troubleshooting section.
- 3 - A55 Unit Controller receives a thermostat demand. After the A55 proves (P259-7 and -6) that B3 blower motor internal relay (KL2-2 and -3) is closed, B3 blower motor is energized (0-10VDC from P259-4 to KL3-4). B3 blower motor controls are grounded through KL2-2 and -3 to A55 P259-6.
- 4 - If configured, A55 checks S52 blower proving switch to make sure it closes within 16 seconds of the 0-10VDC signal being sent to B3 blower motor.

Blower Fault Sequence Direct Drive Motor - No S52:

- 1 - Line voltage is provided to B3 blower motor.
- 2 - After 10 seconds, the B3 blower motor internal relay does not close.
- 3 - Alarm 186 is set by the A55 Unit Controller, de-energizing unit. If one of the "Error" failures listed in TABLE 16 occurs ("Warning" failures will not set Alarm 186), service is required. Refer to the Failure Handling/Troubleshooting section.
- 4 - If B3 blower motor internal relay closes continue to next step.
- 5 - A55 sends 0-10VDC signal to B3 blower motor.
- 6 - \During B3 blower motor operation, the internal motor relay opens.
- 7 - \Alarm 186 is set by A55 and de-energizes the unit. Service is required. Refer to the Failure Handling/Troubleshooting section.

Blower Fault Sequence Direct Drive Motor - With S52 (If Configured):

- 1 - A55 Unit Controller sends 0-10VDC signal to B3 blower motor.
- 2 - After 16 seconds, if S52 blower proving switch remains open, A55 will remove 0-10VDC signal for 5 minutes.
- 3 - A55 sends 0-10VDC signal to B3 blower motor.
- 4 - After 16 seconds, if S52 blower proving switch remains open, A55 will remove 0-10VDC signal for another 5 minutes.
- 5 - After the third try, A55 will de-energize the unit. Service is required.

Failure Handling/Troubleshooting:

- 1 - Follow TABLE 16 to troubleshoot possible failures that would cause Alarm 186 to set.
- 2 - BEFORE DETERMINING THAT THE BLOWER ASSEMBLY HAS FAILED, use the A55 Unit Controller to clear delays and operate the blower.
- 3 - Main Menu > Service > Offline > Clear Delays > Yes > Save
- 4 - Main Menu > Service > Test > Blower
- 5 - Observe if the blower operates or if Alarm 186 sets again.
- 6 - If blower does not operate and Alarm 186 is set again, blower assembly must be replaced.
- 7 - If blower assembly does operate, wait a minimum of 30 minutes to ensure Alarm 186 is not set again.

**TABLE 20
DIRECT DRIVE BLOWER MOTOR TROUBLESHOOTING**

Failure	Error	Warning	Reason	Troubleshoot
Locked Rotor	o		No changes in hall signals within 2000ms	Check for obstruction keeping impeller from rotating
Braking Mode		o	Warning, no error code set, Motor start not possible after 20 sec	Check for secondary airflow source in the system causing the impeller to rotate backwards when off
Hall Error	o		Combination of 3 hall signals gives false signal after one rotation	Measure voltage across each leg, Check electrical connections
Power Module Overheated	o		Temperature > 115°C	Check operating conditions in blower compartment, Check for high motor load (current draw), Check for corrosion-free and secure electrical connections
Motor Overheated	o		Motor over-temperature protector opens	
Gate Driver Error	o		Internal software fault	Measure voltage across each leg, Check electrical connections
Phase Failure	o		Input voltage has phase imbalance	Measure voltage across each leg, Check electrical connections, Repair low/high voltage leg(s)
DC Link Voltage Low	o		Rectified DC link voltage is too low	
DC Link Over-voltage	o		Rectified DC link voltage is too high	
Line Over-voltage	o		Line voltage too high	
Line Under-voltage	o		Line voltage too low	
Communication Error			Internal communication failure. Not connected with master/slave wiring	Check low voltage wiring connections
DC Link Voltage Low		o	Warning, not low enough to set error code	Measure voltage across each leg, Check electrical connections, Repair low/high voltage leg(s)
Electronics Temp High		o	Warning, not high enough to set error code, Temperature > 95°C	Check operating conditions in blower compartment, Check for high motor load (current draw), Check for corrosion-free and secure electrical connections
Power Module Temp High		o	Warning, not high enough to set error code, Temperature > 105°C	
Motor Temp High		o	Warning, not high enough to set error code, Temperature > 130°C	

XI-Decommissioning

Before carrying out this procedure, it is essential that the technician is completely familiar with the equipment and all its detail. It is recommended good practice that all refrigerants are recovered safely. Prior to the task being carried out, an oil and refrigerant sample shall be taken in case analysis is required prior to re-use of recovered refrigerant. It is essential that electrical power is available before the task is commenced.

Steps to ensure this are:

- Become familiar with the equipment and its operation,
- Isolate the system electrically,
- Ensure that before attempting the procedure that mechanical handling equipment is available, if required, for handling refrigerant cylinders, and that all personal protective equipment is available and being used correctly while the recovery process is supervised at all times by a competent person and that the recovery equipment and cylinders conform to the appropriate standards.

Additionally, pump down refrigerant system, if possible, and if a vacuum is not possible, make a manifold so that refrigerant can be removed from various parts of the system. Make sure that cylinders are situated on the scales before recovery takes place. Start the recovery machine and operate in accordance with instructions. Do not overfill cylinders (no more than 80 % volume liquid charge). Do not exceed the maximum working pressure of the cylinder, even temporarily. When the cylinders have been filled correctly and the process completed, make sure that the cylinders and the equipment are removed from site promptly and all isolation valves on the equipment are closed off. Recovered refrigerant shall not be charged into another refrigerating system unless it has been cleaned and checked.

Equipment shall be labeled stating that it has been decommissioned and emptied of refrigerant. The label shall be dated and signed. For appliances containing flammable refrigerants, ensure that there are labels on the equipment stating the equipment contains flammable refrigerant.

Under no circumstances shall potential sources of ignition be used in the searching for or detection of refrigerant leaks. A halide torch (or any other detector using a naked flame) shall not be used. Electronic leak detectors may be used to detect refrigerant leaks but, in the case of flammable refrigerants, the sensitivity may not be adequate, or may need re-calibration. (Detection equipment shall be calibrated in a refrigerant-free area)

Ensure that the detector is not a potential source of ignition and is suitable for the refrigerant used. Leak detection equipment shall be set at a percentage of the LFL of the refrigerant and shall be calibrated to the refrigerant employed, and the appropriate percentage of gas (25 % maximum) is confirmed. Leak detection fluids are also suitable for use with most refrigerants but the use of detergents containing chlorine shall be avoided as the chlorine may react with the refrigerant and corrode the copper pipe-work. If a leak is suspected, all naked flames shall be removed/extinguished. If a leakage of refrigerant is found which requires brazing, all of the refrigerant shall be recovered from the system, or isolated (by means of shut off valves) in a part of the system remote from the leak.

When breaking into the refrigerant circuit to make repairs – or for any other purpose – conventional procedures shall be used. However, for flammable refrigerants it is important that best practice be followed, since flammability is a consideration. The following procedure shall be adhered to:

- Safely remove refrigerant following local and national regulations,
- Evacuate the circuit,
- Purge the circuit with inert gas,
- Evacuate,
- Purge with inert gas,
- Open the circuit.

The refrigerant charge shall be recovered into the correct recovery cylinders if venting is not allowed by local and national codes. For appliances containing flammable refrigerants, the system shall be purged with oxygen-free nitrogen to render the appliance safe for flammable refrigerants. This process might need to be repeated several times. Compressed air or oxygen shall not be used for purging refrigerant systems. Refrigerant purging shall be achieved by breaking the vacuum in the system with oxygen-free nitrogen and continuing to fill until the working pressure is achieved, then venting to atmosphere, and finally pulling down to a vacuum. This process shall be repeated until no refrigerant is within the system. When the final oxygen-free nitrogen charge is used, the system shall be vented down to atmospheric pressure to enable work to take place. Ensure that the outlet for the vacuum pump is not close to any potential ignition sources and that ventilation is available.