

INSTALLATION INSTRUCTIONS

⚠ WARNING

To prevent serious injury or death:

- 1- Lock-out/tag-out before performing maintenance.
- 2- If system power is required (e.g., smoke detector maintenance), disable power to blower, remove fan belt where applicable, and ensure all controllers and thermostats are set to the “OFF” position before performing maintenance.
- 3- Always keep hands, hair, clothing, jewelry, tools, etc., away from moving parts.

Table of Contents

Dimensions	4
Parts Arrangement	5
Shipping and Packing List	6
General	6
Requirements	6
Unit Support	6
Duct Connection	9
Rigging Unit for Lifting	9
Horizontal Air Discharge	9
Condensate Drains	10
High Altitude Derate	11
Electrical Connections - Power Supply	11
Electrical Connections - Control Wiring	11
Balance Point Setpoint	13
Unit Power-Up	13
Mobile Service App	14
Blower Operation and Adjustments	17
Refrigerant Leak Detection System	27

- LHX024** (2 TON)
- LHX036** (3 TON)
- LHX048** (4 TON)
- LHX060** (5 TON)

HEAT PUMP PACKAGED UNITS

508512-01
5/2024

R-454B

Start-Up	27
Defrost Control	30
Diagnostic Sensors	30
RDS Sensors	34
Cooling Operation	35
Heating Operation and Adjustments	36
Heat Start-Up	36
SCR Electric Heat Controller	36
Preventative Maintenance / Repair	36
Factory Unit Controller Settings	44
Decommissioning	47

⚠ WARNING

Improper installation, adjustment, alteration, service or maintenance can cause property damage, personal injury or loss of life. Installation and service must be performed by a licensed professional HVAC installer or equivalent, service agency, or the gas supplier.

RETAIN THESE INSTRUCTIONS FOR FUTURE REFERENCES

Attention!

Use this QR code to download the mobile service app. Follow the prompts to pair the app with the Unit Controller. Refer to the “Mobile Service App” section in this manual. The QR code is also available in the unit control area.



The app can be downloaded from the appropriate iOS or Android store. Look for the following icon.



CAUTION

As with any mechanical equipment, contact with sharp sheet metal edges can result in personal injury. Take care while handling this equipment and wear gloves and protective clothing.

WARNING

Only manufacturer approved auxiliary devices are permitted to be installed in this unit.

WARNING

If this appliance is conditioning a space with an area smaller than T_{Amin} or stored in a space with an area smaller than A_{min} as defined by this instruction, then that space must be without continuously operating open flames (e.g. an operating gas appliance) or other potential ignition sources (e.g. an operating electric heater or similar hot surface). A flame-producing device may be installed in the same space if the device is provided with an effective flame arrest system.

WARNING

- Do not use means to accelerate the defrosting process or to clean, other than those recommended by the manufacturer.
- The appliance shall be stored in a room without continuously operating ignition sources (for example: open flames, an operating gas appliance, or an operating electric heater).
- Do not pierce or burn.
- Be aware that refrigerants may not contain an odor.

CAUTION

Auxiliary devices which may be a potential ignition source shall not be installed in the duct work. Examples of such potential ignition sources are hot surfaces with a temperature exceeding 700°C and electric switching devices.

CAUTION

Any personnel installing, decommissioning, or performing maintenance on the unit must be properly trained with A2L refrigerants.

CAUTION

Leak Detection System installed. Unit must be powered except for service.

CAUTION

Servicing shall be performed only as recommended by the manufacturer.

WARNING

- This appliance must be installed in accordance with local and national wiring regulations.
- If the appliance is not fitted with an option for full disconnection from power, a means of disconnection must be incorporated in the fixed wiring in accordance with national and local wiring regulations.

WARNING

Ducts connected to an appliance shall not contain a potential ignition source.

CAUTION

The appliance is not to be used by persons (including children) with reduced physical, sensory or mental capabilities, or lack of experience and knowledge, unless they have been given supervision or instruction

CAUTION

Children should be supervised not to play with the appliance.

IMPORTANT

Pipe work, including piping material, pipe routing, and installation shall include protection from physical damage in operation and service, and be in compliance with national and local codes and standards, such as ASHRAE 15, ASHRAE 15.2, IAPMO Uniform Mechanical Code, ICC International Mechanical Code, or CSA B52. All field joints shall be accessible for inspection prior to being covered or enclosed.

IMPORTANT

Refrigerant sensors for refrigerant detection systems shall only be replaced with sensors specified by the appliance manufacture.

CAUTION

This unit is equipped with electrically powered safety measures. To be effective, the unit must be electrically powered at all times after installation, other than when servicing.

A2L Refrigerant Considerations

Ensure that the work area is adequately ventilated before breaking into the system or conducting any hot work. A degree of ventilation shall continue during the period that the work is carried out. The ventilation should safely disperse any released refrigerant and preferably expel it externally into the atmosphere.

Check that cabling will not be subject to wear, corrosion, excessive pressure, vibration, sharp edges or any other adverse environmental effects, taking into account the effects of aging or continual vibration from sources such as compressors or fans.

Under no circumstances shall potential sources of ignition be used when searching for or detecting refrigerant leaks. A halide torch (or any other detector using a naked flame) shall not be used. Electronic leak detectors may be used to detect refrigerant leaks but, in the case of flammable refrigerants, the sensitivity may not be adequate, or may need re-calibration. (Detection equipment shall be calibrated in a refrigerant-free area.) Ensure that the detector is not a potential source of ignition and is suitable for the refrigerant used. Leak detection equipment shall be set at a percentage of the LFL of the refrigerant and shall be calibrated to the refrigerant employed, and the appropriate percentage of gas (25% maximum) is confirmed. Leak detection fluids are also suitable for use with most refrigerants but the use of detergents containing chlorine shall be avoided as the chlorine may react with the refrigerant and corrode the copper pipe-work. If a leak is suspected, all naked flames shall be removed/ extinguished. If a leakage of refrigerant is found which requires brazing, all of the refrigerant shall be recovered from the system, or isolated (by means of shut off valves) in a part of the system remote from the leak.

When breaking into the refrigerant circuit to make repairs – or for any other purpose – conventional procedures shall be used. However, for flammable refrigerants it is important that best practices be followed since flammability is a consideration. The following procedure shall be adhered to:

- Safely remove refrigerant following local and national regulations.
- Evacuate the circuit.
- Purge the circuit with inert gas.
- Evacuate.
- Purge the circuit with inert gas.
- Open the circuit

The refrigerant charge shall be recovered into the correct recovery cylinders if venting is not allowed by local and national codes. For appliances containing flammable refrigerants, the system shall be purged with oxygen-free nitrogen to render the appliance safe for flammable refrigerants. This process might need to be repeated several times. Compressed air or oxygen shall not be used for purging refrigerant systems. Refrigerants purging shall be achieved by breaking the vacuum in the system with oxygen-free nitrogen and continuing to fill until the working pressure is achieved, then venting to atmosphere, and finally pulling down to a vacuum. This process shall be vented down to atmospheric pressure to enable work to take place. Ensure that the outlet for the vacuum pump is not close to any potential ignition sources and that ventilation is available.

LHX024, 036, 048, 060 DIMENSIONS in. - Gas heat section shown

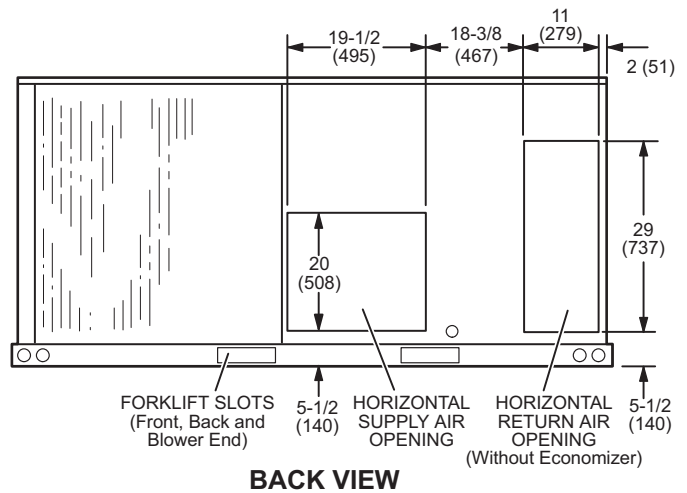
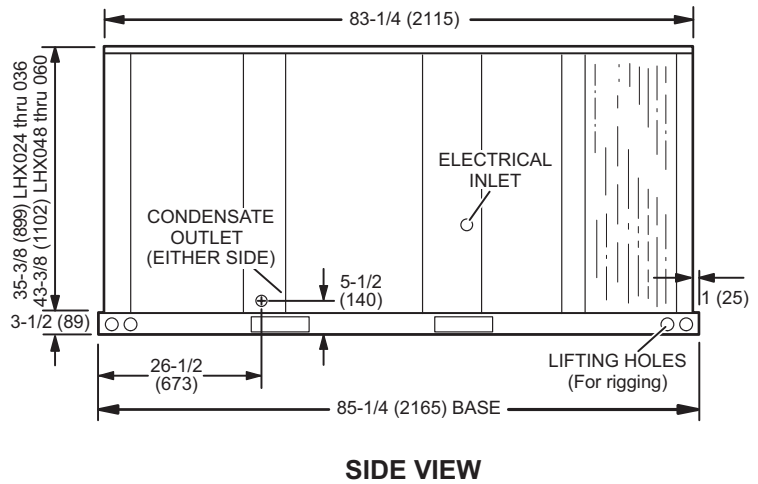
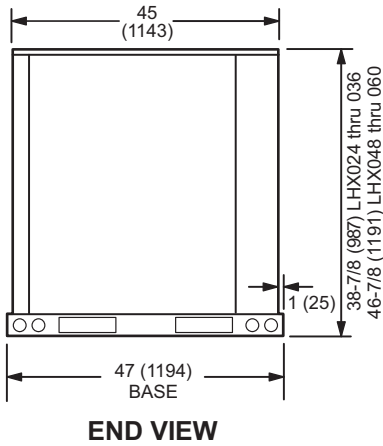
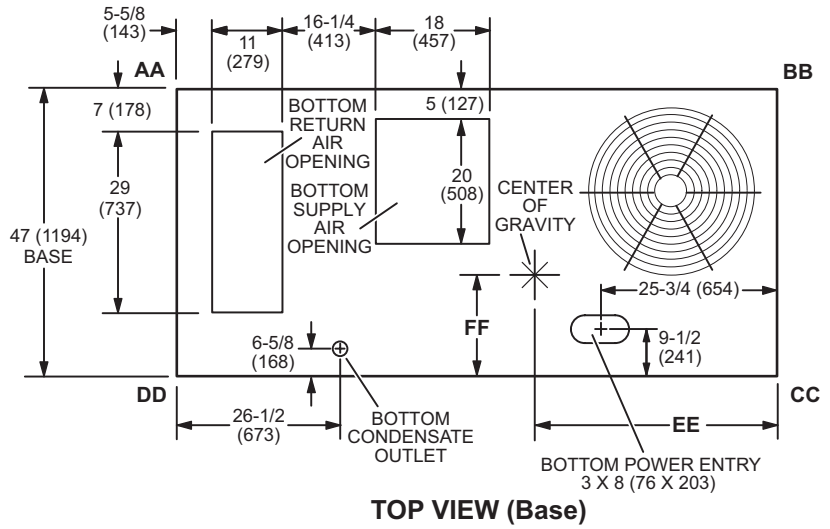

LHX024, 036, 048, 060 PARTS ARRANGEMENT

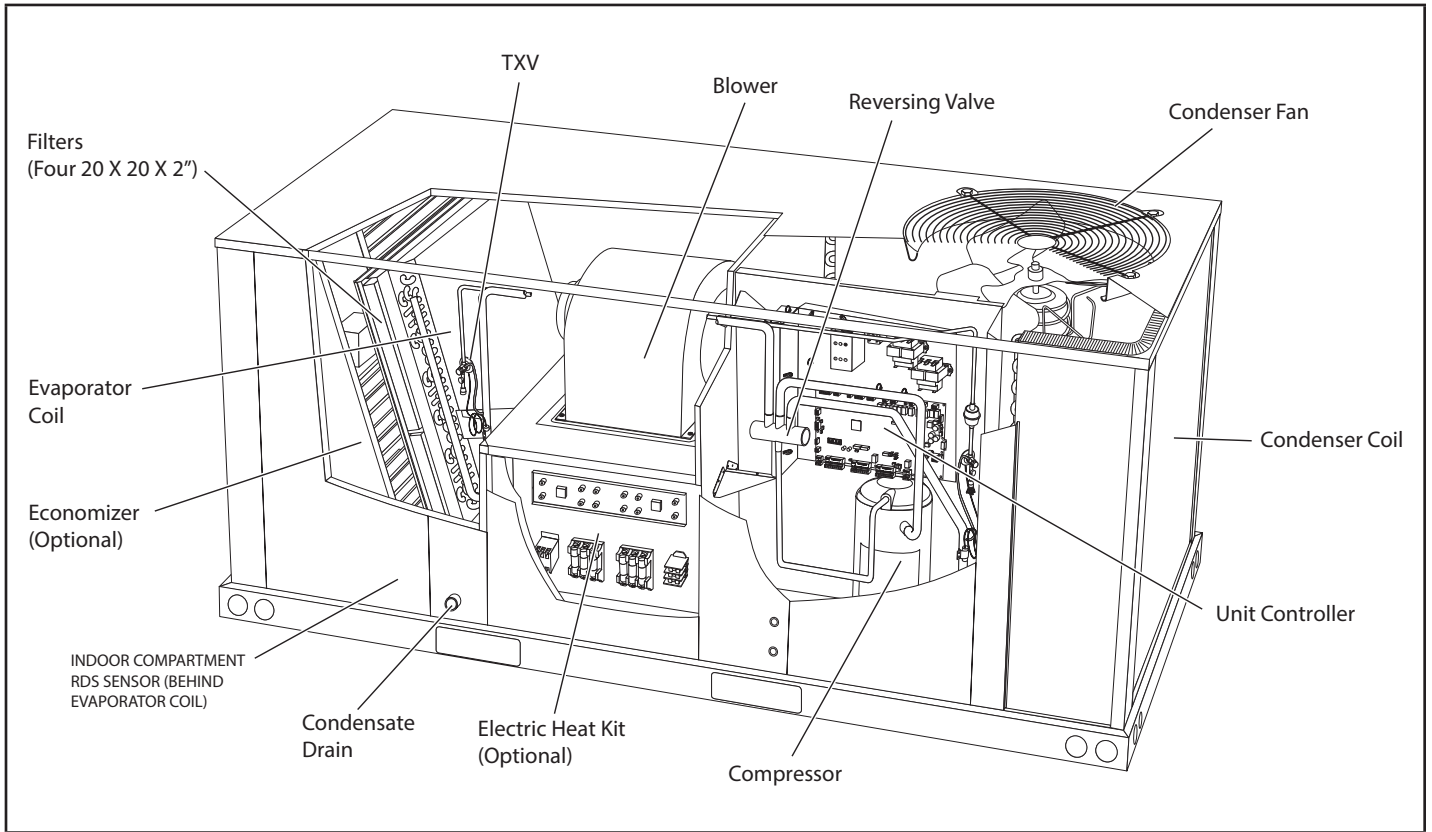

Shipping and Packing List

Package 1 of 1 contains:

1 - Assembled unit

Check unit for shipping damage. Receiving party should contact last carrier immediately if shipping damage is found.

General

These instructions are intended as a general guide and do not supersede local codes in any way. Authorities having jurisdiction should be consulted before installation.

The LHX units have 2, 3, 4, and 5-ton cooling capacities.

Units are equipped with fin/tube condenser coils, two speed compressors, and variable speed, direct drive blowers. Compressor and supply air speeds adjust to system demand.

Availability of units and options varies by brand.

Requirements

See FIGURE 1 for unit clearances.

The LHX unit is ETL/CSA certified as a heat pump with cooling and with or without auxiliary electric heat for outdoor installations only at the clearances to combustibles as listed on the unit nameplate and in FIGURE 1.

Installation of LHX units must conform with standards in National Fire Protection Association (NFPA) "Standard for Installation of Air Conditioning and Ventilating Systems NFPA No. 90A," "Standard for Installation of Residence Type Warm Air Heating and Air Conditioning Systems NFPA No. 90B," local municipal building codes and manufacturer's installation instructions.

⚠ IMPORTANT

The Clean Air Act of 1990 bans the intentional venting of refrigerant (CFC's and HCFC's) as of July 1, 1992. Approved methods of recovery, recycling or reclaiming must be followed. Fines and/or incarceration may be levied for non-compliance.

⚠ WARNING



Electric shock hazard and danger of explosion. Can cause injury, death or product or property damage. Turn off gas and electrical power to unit before performing any maintenance or servicing operations on the unit. Follow lighting instructions attached to unit when putting unit back into operation and after service or maintenance.

⚠ NOTICE

Roof Damage!

This system contains both refrigerant and oil. Some rubber roofing material may absorb oil, causing the rubber to swell. Bubbles in the rubber roofing material can cause leaks. Protect the roof surface to avoid exposure to refrigerant and oil during service and installation. Failure to follow this notice could result in damage to roof surface.

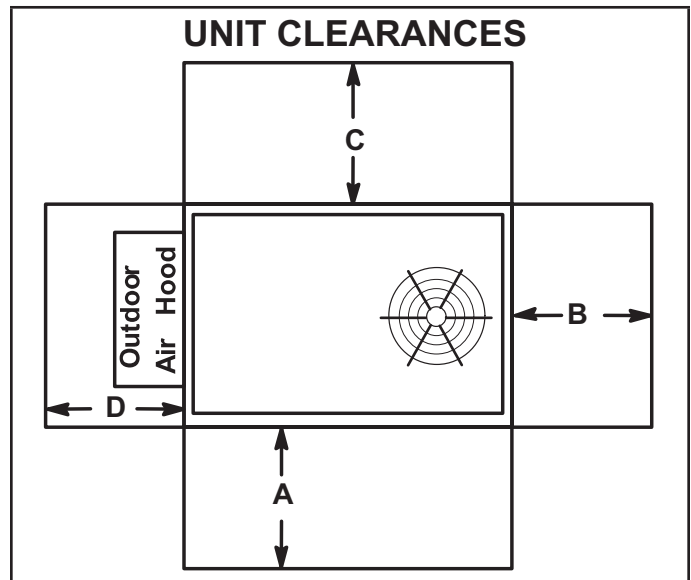

FIGURE 1

¹ Unit Clearance	A in- (mm)	B in- (mm)	C in- (mm)	D in- (mm)	Top Clearance
Service Clearance	48 (1219)	36 (916)	36 (916)	36 (916)	Unobstructed
Clearance to Combustibles	36 (916)	1 (25)	1 (25)	1 (25)	Unobstructed
Minimum Operation Clearance	36 (916)	36 (916)	36 (916)	36 (916)	Unobstructed

NOTE - Entire perimeter of unit base requires support when elevated above mounting surface.

¹ **Service Clearance** - Required for removal of serviceable parts.
Clearance to Combustibles - Required clearance to combustible material (gas units). On LCT units, see clearance to combustible materials as outlined on heater rating plate.
Minimum Operation Clearance - Required clearance for proper unit operation.

Minimum R454B Space and CFM Requirements

Minimum Airflow ¹		
Unit	Q _{min} (CFM)	Q _{min} (m ³ h)
LHX024	371	629
LHX036	344	584
LHX048	444	753
LHX060	414	703

¹ **NOTE** - The minimum airflow is the lowest CFM allowed during venting operation (leak mitigation).

Refrigerant Charge R-454B		
Unit	M _c (lbs)	M _c (kg)
LHX024	14.00	6.35
LHX036	13.00	5.90
LHX048	16.75	7.60
LHX060	15.65	7.10

Minimum Room Area of Conditioned Space ²		
Unit	TA _{min} (ft ²)	TA _{min} (m ²)
LHX024	206.0	19.1
LHX036	191.0	17.7
LHX048	246.0	22.8
LHX060	230.0	21.3

² **NOTE** - The minimum room area of conditioned space is the smallest area the unit can service.

Altitude Adjustment Factor ³									
Halt	0	200	400	600	800	1000	1200	1400	1600
AF	1	1	1	1	1.02	1.05	1.07	1.1	1.12
Halt	1600	1800	2000	2200	2400	2600	2800	3000	3200
AF	1.12	1.15	1.18	1.21	1.25	1.28	1.32	1.36	1.40

³ **NOTE** - Use the Altitude Adjustment Factor to adjust the values in the tables above to different altitudes. Find the relevant altitude above sea level in the two "Halt" rows and then multiply the value needed from the tables above by the altitude factor number. Example: For the minimum airflow in CFM for an LHX024 at 1000 ft. above sea level, multiply 371 by 1.05 to get 389.55 CFM as the new Q_{min}.

Use of this unit as a construction heater or air conditioner is not recommended during any phase of construction. Very low return air temperatures, harmful vapors and operation of the unit with clogged or misplaced filters will damage the unit.

If this unit has been used for heating or cooling of buildings or structures under construction, the following conditions must be met or the warranty will be void:

- A room thermostat must control the unit. The use of fixed jumpers that will provide continuous heating or cooling is not allowed.
- A pre-filter must be installed at the entry to the return air duct.
- The return air duct must be provided and sealed to the unit.
- Return air temperature range between 55°F (13°C) and 80°F (27°C) must be maintained.
- Air filters must be replaced and pre-filters must be removed upon construction completion.
- The input rate and temperature rise must be set per the unit rating plate.
- The heat exchanger, components, duct system, air filters and evaporator coil must be thoroughly cleaned following final construction clean-up.
- The unit operating conditions (including airflow, cooling operation, ignition, input rate, temperature rise and venting) must be verified according to these installation instructions.

This appliance is not intended for use by persons (including children) with reduced physical, sensory, or mental capabilities, or lack of experience and knowledge, unless they have been given supervision or instruction concerning use of the appliance by a person responsible for their safety.

Unit Support

In downflow discharge installations, install the unit on a non-combustible surface only. Unit may be installed on combustible surfaces when used in horizontal discharge applications or in downflow discharge applications when installed on an T1CURB / C1CURB / E1CURB roof mounting frame.

NOTE - Securely fasten roof frame to roof per local codes.

CAUTION

To reduce the likelihood of supply / return air bypass and promote a proper seal with the RTU, duct work / duct drops / diffuser assemblies must be supported independently to the building structure.

A-Downflow Discharge Application

Roof Mounting with T1CURB / C1CURB / E1CURB

- 1 - The roof mounting frame must be installed, flashed and sealed in accordance with the instructions provided with the frame.
- 2 - The roof mounting frame should be square and level to 1/16" per linear foot (5mm per linear meter) in any direction.
- 3 - Duct must be attached to the roof mounting frame and not to the unit; supply and return plenums must be installed before setting the unit.

Installer's Roof Mounting Frame

Many types of roof frames can be used to install the unit depending upon different roof structures. Items to keep in mind when using the building frame or supports are:

- 1 - The base is fully enclosed and insulated, so an enclosed frame is not required.
- 2 - The frames or supports must be constructed with non-combustible materials and should be square and level to 1/16" per linear foot (5mm per linear meter) in any direction.
- 3 - Frame or supports must be high enough to prevent any form of moisture from entering unit. Recommended minimum frame height is 14" (356mm).
- 4 - Duct must be attached to the roof mounting frame and not to the unit. Supply and return plenums must be installed before setting the unit.
- 5 - Units require support along all four sides of unit base. Supports must be constructed of steel or suitably treated wood materials.

NOTE - When installing a unit on a combustible surface for downflow discharge applications, a T1CURB / C1CURB / E1CURB roof mounting frame is required.

B-Horizontal Discharge Applications

- 1 - Units which are equipped with an optional economizer and installed in horizontal airflow applications must use a horizontal conversion kit.
- 2 - Specified installation clearances must be maintained when installing units. Refer to FIGURE 1.
- 3 - Top of support slab should be approximately 4" (102mm) above the finished grade and located so no run-off water from higher ground can collect around the unit.
- 4 - Units require support along all four sides of unit base. Supports must be constructed of steel or suitably treated wood materials.

Duct Connection

All exterior ducts, joints and openings in roof or building walls must be insulated and weather-proofed with flashing and sealing compounds in accordance with applicable codes. Any duct passing through an unconditioned space must be insulated.

⚠ CAUTION

In downflow applications, do not drill or punch holes in base of unit. Leaking in roof may occur if unit base is punctured.

Rigging Unit for Lifting

Rig unit for lifting by attaching four cables to holes in unit base rail. See FIGURE 2.

- 1 - Detach wooden base protection before rigging.
- 2 - Remove all six base protection brackets before setting unit.
- 3 - Connect rigging to the unit base using both holes in each corner.
- 4 - All panels must be in place for rigging.
- 5 - Place field-provided H-style pick in place just above top edge of unit. Frame must be of adequate strength and length. (H-style pick prevents damage to unit.)

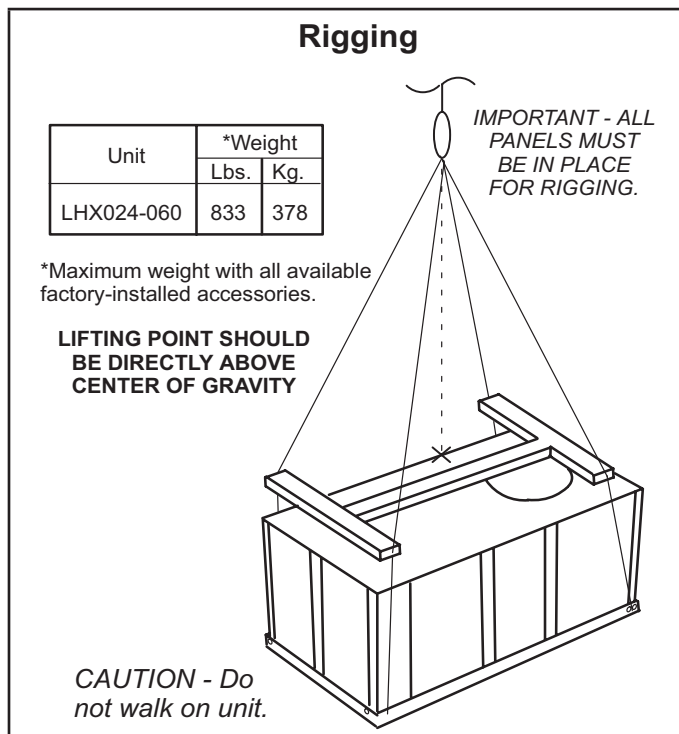

FIGURE 2

Horizontal Air Discharge

Unit is shipped with panels covering the horizontal supply and return air openings. Remove horizontal covers and place over downflow openings for horizontal air discharge. See FIGURE 3. Secure in place with sheet metal screws.

Units Equipped With An Optional Economizer

- 1 - Remove the horizontal supply air cover and position over the downflow supply air opening. Secure with sheet metal screws.
- 2 - Leave the horizontal return air cover in place.
- 3 - Locate the separately ordered horizontal air discharge kit. Place the kit panel over the downflow return air opening.
- 4 - Remove and retain the barometric relief dampers and lower hood.

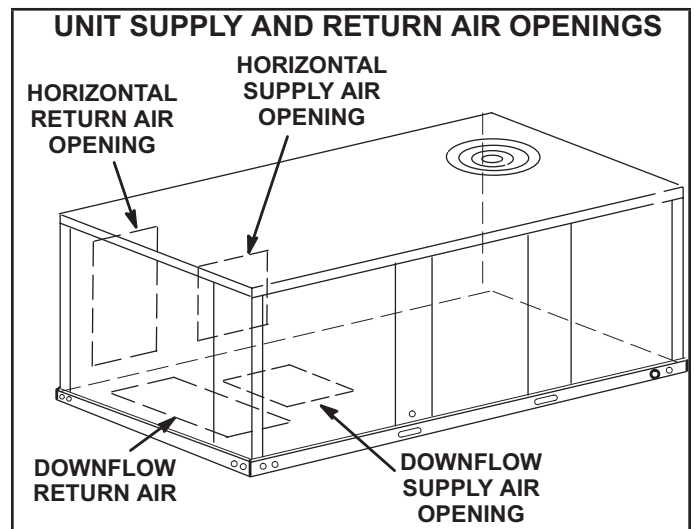

FIGURE 3

- 5 - Install return air duct beneath outdoor air intake. See FIGURE 4. Install barometric relief damper in lower hood and install in ductwork as shown in FIGURE 4.

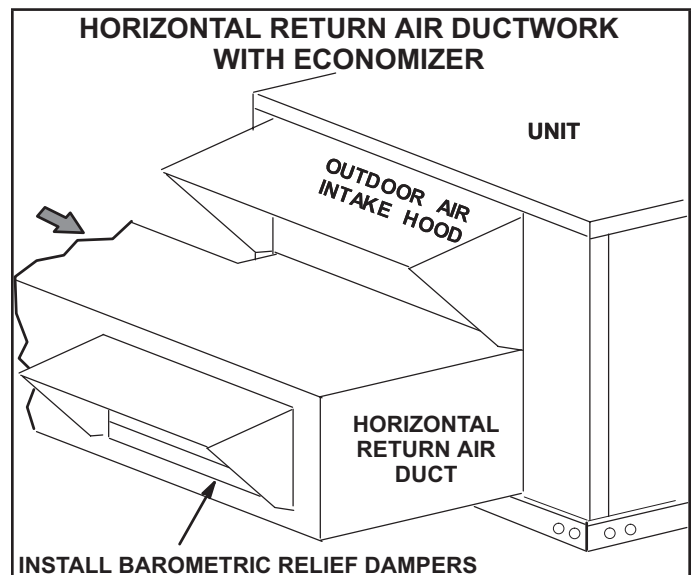

FIGURE 4

Condensate Drains

Make drain connection to the drain coupling provided on unit. Older model units have a 3/4" N.P.T. coupling and newer model units have a 1" N.P.T. coupling.

NOTE - The drain pan is made with a glass reinforced engineered plastic capable of withstanding typical joint torque but can be damaged with excessive force. Tighten pipe nipple hand tight and turn an additional quarter turn.

A trap must be installed between drain connection and an open vent for proper condensate removal. See FIGURE 5 or FIGURE 6. It is sometimes acceptable to drain condensate onto the roof or grade; however, a tee should be fitted to the trap to direct condensate downward. The condensate line must be vented. Check local codes concerning condensate disposal. Refer to page 4 and page 5 for condensate drain location.

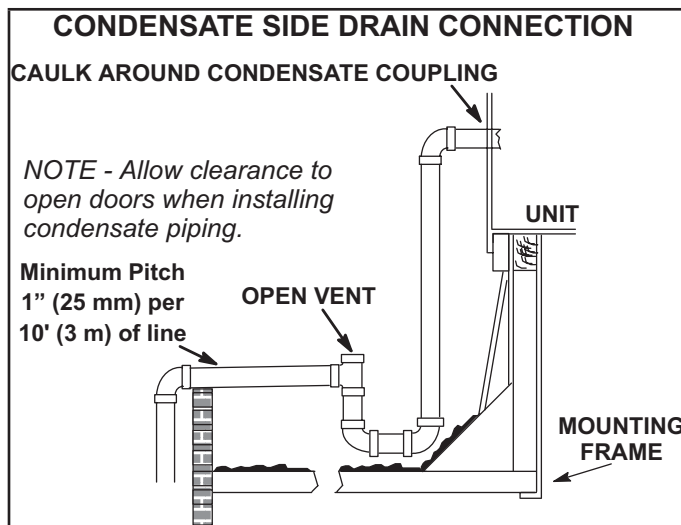

FIGURE 5

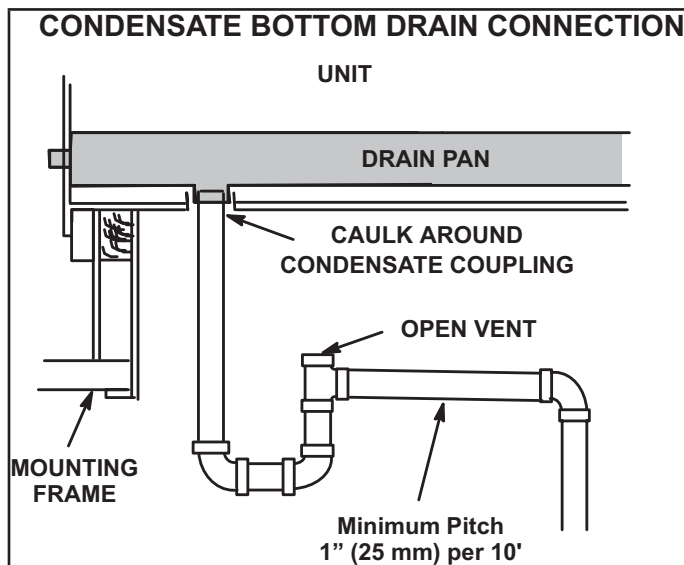

FIGURE 6

Units are shipped with the drain coupling facing the front of the unit. Condensate can be drained from the back or bottom of the unit with the following modifications. The unit can be installed in either downflow or horizontal air discharge regardless of condensate drain location.

Rear Drain Connection

- 1 - Remove the condensate drain mullion. See FIGURE 7. Remove the two panels on each side of the mullion.

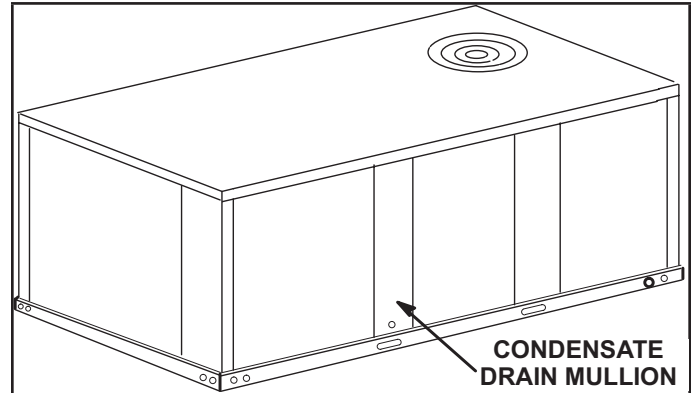

FIGURE 7

Two hinge screws must be removed in addition to the mullion screws. See FIGURE 8.

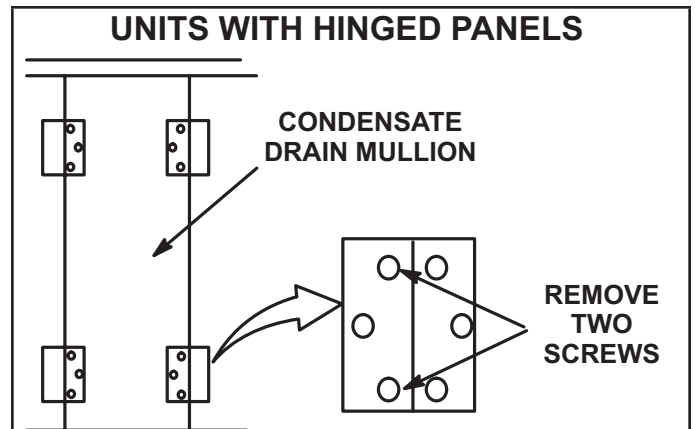

FIGURE 8

- 2 - Lift the front edge of the drain pan and slide pan out of unit. See FIGURE 9.

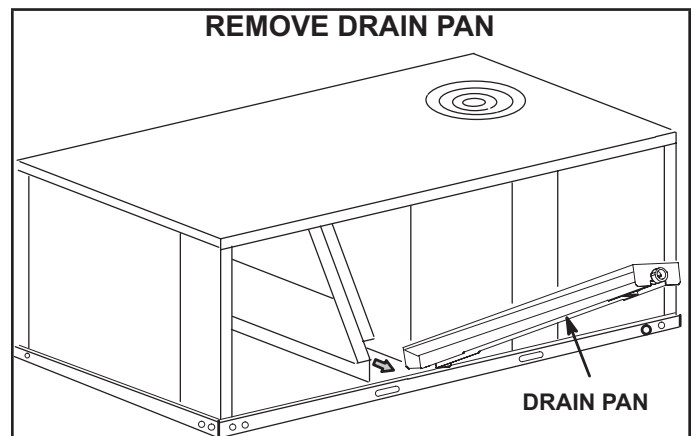

FIGURE 9

- 3 - Make sure the cap over the unit bottom drain hole is secure.
- 4 - Rotate the drain pan until the downward slope is toward the back of the unit. Slide the drain pan back into the unit. Be careful not to dislodge the cap over the bottom drain hole.
- 5 - From the back side of the unit, pull the drain pan coupling through the rear condensate opening.
- 6 - Replace the condensate drain mullion.

Bottom Drain Connection

- 1 - Remove the condensate drain mullion. See FIGURE 7.
- 2 - Lift the front edge of the drain pan and slide pan out of unit. See FIGURE 9.
- 3 - Turn the drain pan upside down and drill a pilot hole through the bottom of the drain pan in the center of the coupling. See FIGURE 10.

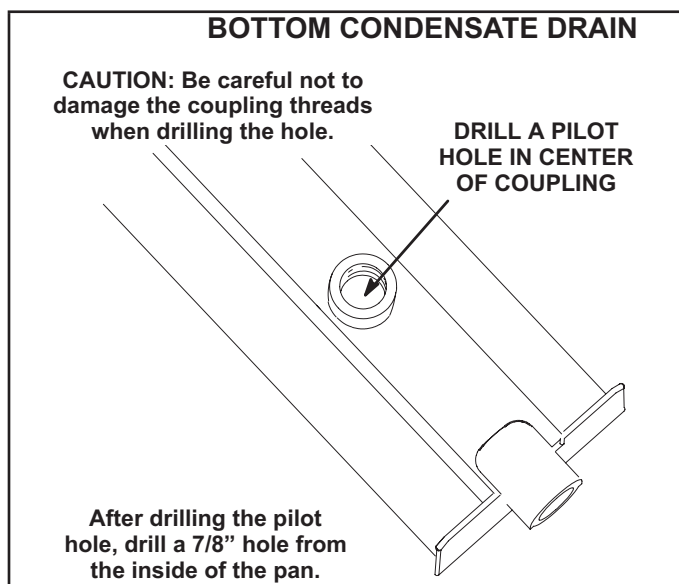

FIGURE 10

- 4 - From the inside of the pan, use a Vari-Bit® bit to enlarge the hole to 7/8". Do not damage coupling threads.
- 5 - Remove the cap over the unit bottom drain hole.
- 6 - Slide the drain pan back into the unit.
- 7 - From the back side of the unit, pull the drain pan coupling through the rear condensate opening.
- 8 - From the front side of the unit, move the drain pan until the bottom coupling settles into the unit bottom drain opening. Once in place, check to make sure the coupling is still positioned through the rear condensate drain hole.
- 9 - Use a field-provided 3/4" plug to seal side drain connection.
- 10 - Replace the condensate drain mullion.

High Altitude Derate

Locate the high altitude conversion sticker in the unit literature bag. Fill out the conversion sticker and affix next to the unit nameplate. High altitude kits are available for field-installation.

Refer to TABLE 1 for high altitude adjustments.

**TABLE 1
HIGH ALTITUDE DERATE**

Altitude Ft.*	Gas manifold Pressure
2000-4500	See Unit Nameplate
4500 and Above	Derate 2% / 1000 Ft. above Sea Level

*Units installed at 0-2000 feet do not need to be modified.

NOTE - This is the only permissible derate for these units.

Electrical Connections - Power Supply

Do not apply power or close disconnect switch until installation is complete. Refer to start-up directions. Refer closely to unit wiring diagram.

Refer to unit nameplate for minimum circuit ampacity and maximum fuse size.

- 1 - Units are factory-wired for 230 / 460 / 575 volt supply. For 208V supply, remove the insulated terminal cover from the 208V terminal on the control transformer.
- 2 - Move the wire from the transformer 240V terminal to the 208V terminal. Place the insulated terminal cover on the unused 240V terminal.

Route power through the bottom power entry area and connect to L1, L2, and L3 on the top of K1 in control area above compressor. Secure power wiring with factory-installed wire ties provided in control box. Route power to TB2 on units equipped with electric heat. Route power to S48 or CB10 if unit is equipped with the optional disconnect switch or circuit breaker. See unit wiring diagram.

Electrical Connections - Control Wiring

Connect either a thermostat, room/zone sensor, or direct digital controller; one of the three are required for unit function. Refer to the literature provided with each device and the following information.

NOTE - Optional wireless sensors are available for use with this unit. Refer to the instructions provided with each sensor.

⚠ CAUTION

Electrostatic discharge can affect electronic components. Take precautions during unit installation and service to protect the electronic controls. Precautions will help to avoid control exposure to electrostatic discharge by putting the unit, the control and the technician at the same electrostatic potential. Neutralize electrostatic charge by touching hands and all tools on an unpainted unit surface, such as the gas valve or blower deck, before performing any service procedure.

A-Thermostat Location

Room thermostat mounts vertically on a standard 2" X 4" handy box or on any non-conductive flat surface.

Locate thermostat approximately 5 feet (1524mm) above the floor in an area with good air circulation at average temperature. Avoid locating the room thermostat where it might be affected by:

- drafts or dead spots behind doors and in corners
- hot or cold air from ducts
- radiant heat from sun or appliances
- concealed pipes and chimneys

B-Control Wiring

The Unit Controller will operate the unit from a thermostat or zone sensor based on the System Mode. The default System Mode is the thermostat mode. Refer to the Unit Controller Setup Guide to change the System Mode. Use the mobile service app menu and select *Settings > Install*.

Thermostat Mode

- 1 - Route thermostat cable or wires from subbase to control area above compressor (refer to unit dimensions to locate bottom and side power entry).

IMPORTANT - Unless field thermostat wires are rated for maximum unit voltage, they must be routed away from line voltage wiring. Use wire ties located near the lower left corner of the controls mounting panel to secure thermostat cable.

Use 18 AWG wire for all applications using remotely installed electro-mechanical and electronic thermostats.

- 2 - Install thermostat assembly in accordance with instructions provided with thermostat.
- 3 - Connect thermostat wiring to Unit Controller on the lower side of the controls hat section.
- 4 - Wire as shown in FIGURE 11 for electro-mechanical and electronic thermostats. If using other temperature control devices or energy management systems see instructions and wiring diagram provided by manufacturer.

IMPORTANT - Terminal connections at the wall plate or subbase must be made securely. Loose control wire connections may allow unit to operate but not with proper response to room demand.

Zone Sensor Mode

The Unit Controller will operate heating and cooling based on the Unit Controller internal setpoints and the temperature from the A2 zone sensor. An optional Network Control Panel (NCP) can also be used to provide setpoints. A thermostat or return air sensor can be used as a back-up mode. Make zone sensor wiring connections as shown in FIGURE 12.

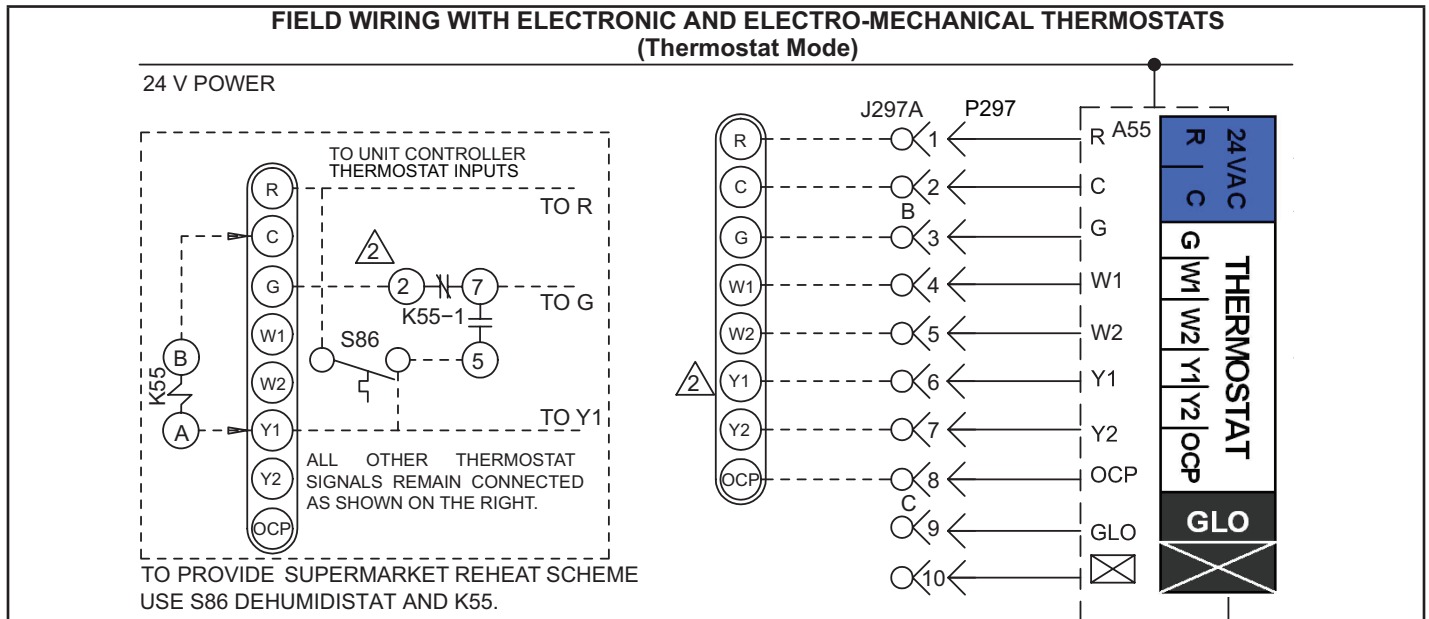

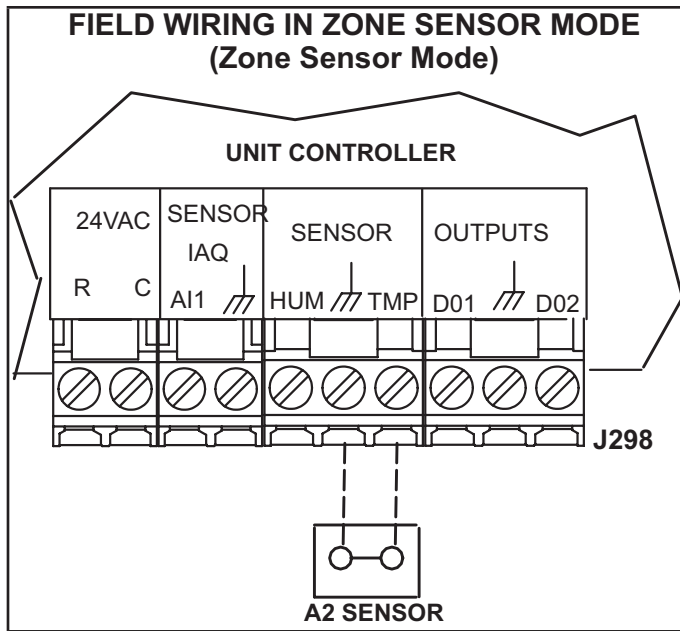

FIGURE 12

Balance Point Setpoint

When outdoor air temperature is above setpoint (35°F default), the unit will operate in heat pump mode. When outdoor air temperature falls below setpoint, the unit will operate in gas heat mode.

NOTE - Only stage one is used; stage 2 is not used.

Although the recommended balance point setpoint is 35°F, the setpoint can be adjusted. Weigh the comfort / cost benefit when increasing the setpoint.

Unit Power-Up

A-General

- 1 - Make sure that unit is installed in accordance with the installation instructions and applicable codes.
- 2 - Inspect all electrical wiring, both field and factory installed, for loose connections. Tighten as required.
- 3 - Check to ensure that refrigerant lines do not rub against the cabinet or against other refrigerant lines.
- 4 - Check voltage at main unit power connection. Voltage must be within range listed on nameplate. If not, consult power company and have voltage condition corrected before starting unit.
- 5 - Make sure filters are in place before start-up.
- 6 - Make sure there is no heating, cooling, or blower demand from thermostat. Apply power to unit.

Mobile Service App

Setup and configure each rooftop unit using the mobile service app (Android or iOS devices supported).

A-Mobile Device Requirements

- Bluetooth connection.
- Android hardware requires 2GB RAM and a 2Ghz core processor. Tablets are supported.
- The app is available for both iOS 11.0 or higher (App Store) and Android 9.0 or higher (Google Play).

B-Download the App

Use your mobile device to scan the QR code from the cover page and download the mobile service app to your mobile device.

C-Pair the App to the Unit Controller

- 1 - Apply power to the unit and wait until the Unit Controller has booted-up (approximately two minutes).
- 2 - Press and hold the pair button for five seconds.
- 3 - The unit (or list of units) will appear; select the appropriate unit. When the app code matches the four-character code on the Unit Controller display, the unit is paired (within 10 seconds). Note the following:
 - The app will list the units by signal strength; the RTU name will be displayed.
 - Once paired, the RTU name, model number, serial number and firmware version will be displayed.

Please refer to the manufacturer’s website for additional technical information and self-help support.

D-App Menus

See FIGURE 13 for the menu overview. Follow the app prompts in the Install, Network Integration, and Test and Balance menus. Verify the app is setup properly for the unit application (including the date and time). Refer to FIGURE 14, FIGURE 15, and FIGURE 16.

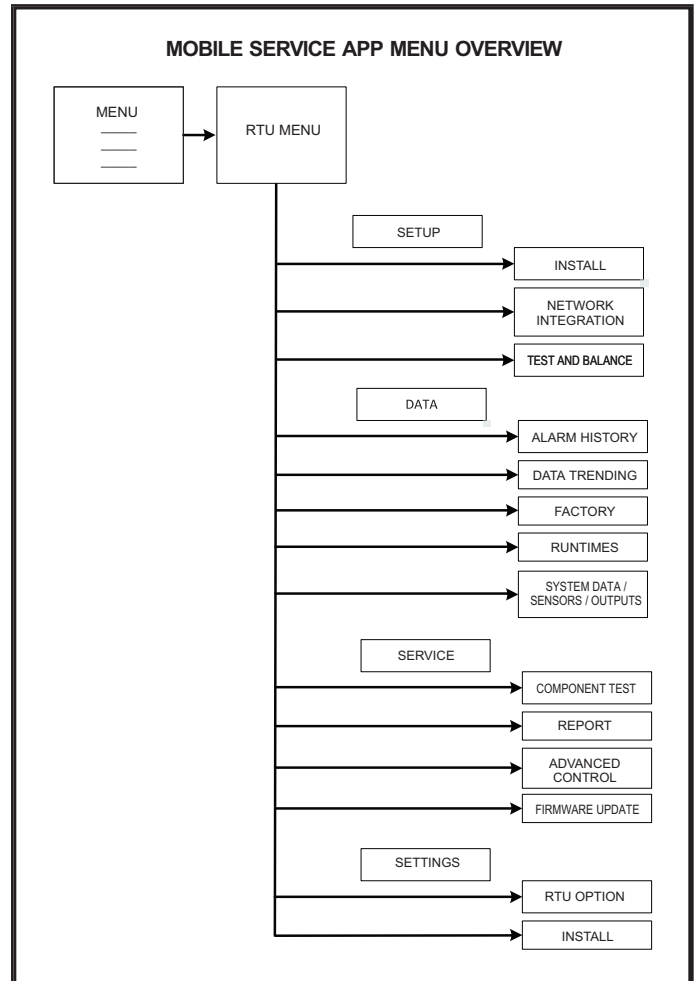

FIGURE 13

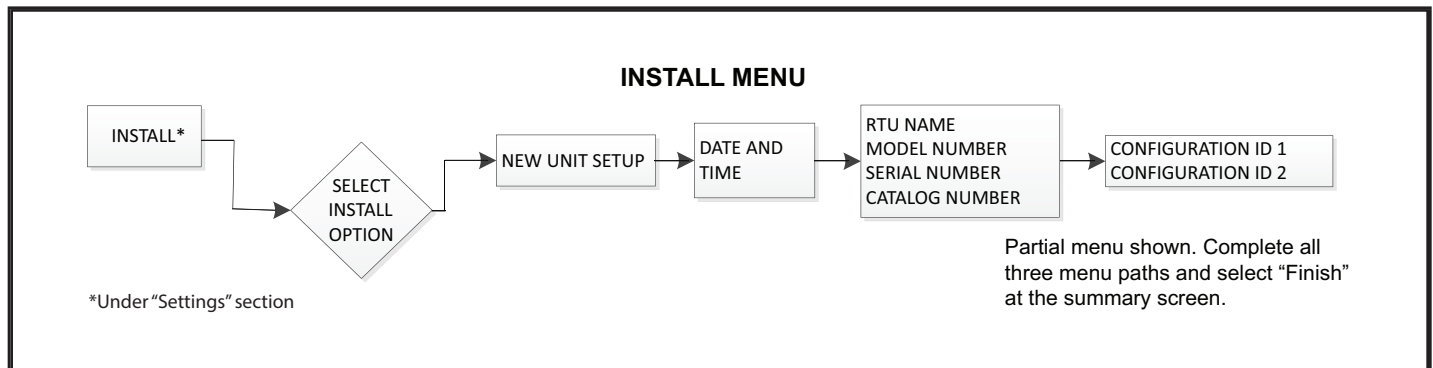

FIGURE 14

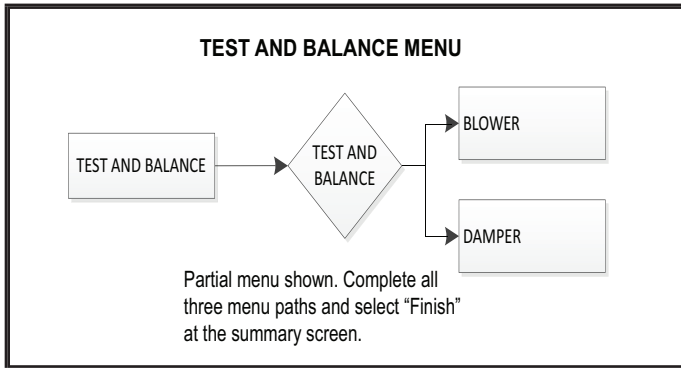

FIGURE 15

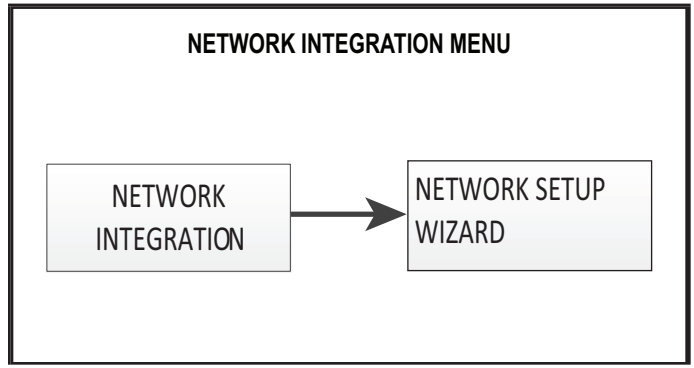

FIGURE 16

E-Unit Controller Components

See FIGURE 17 for Unit Controller components. See FIGURE 18 and TABLE 2 for pushbutton and LED functions.

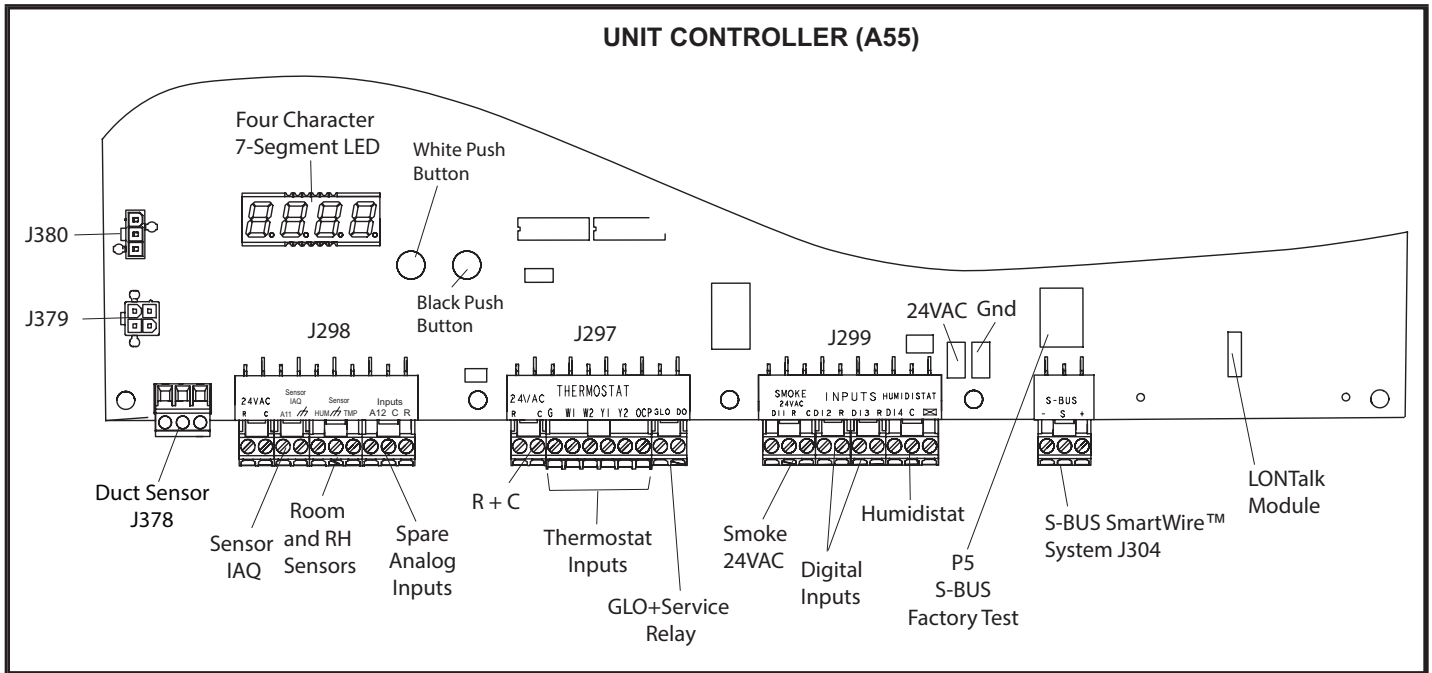

FIGURE 17

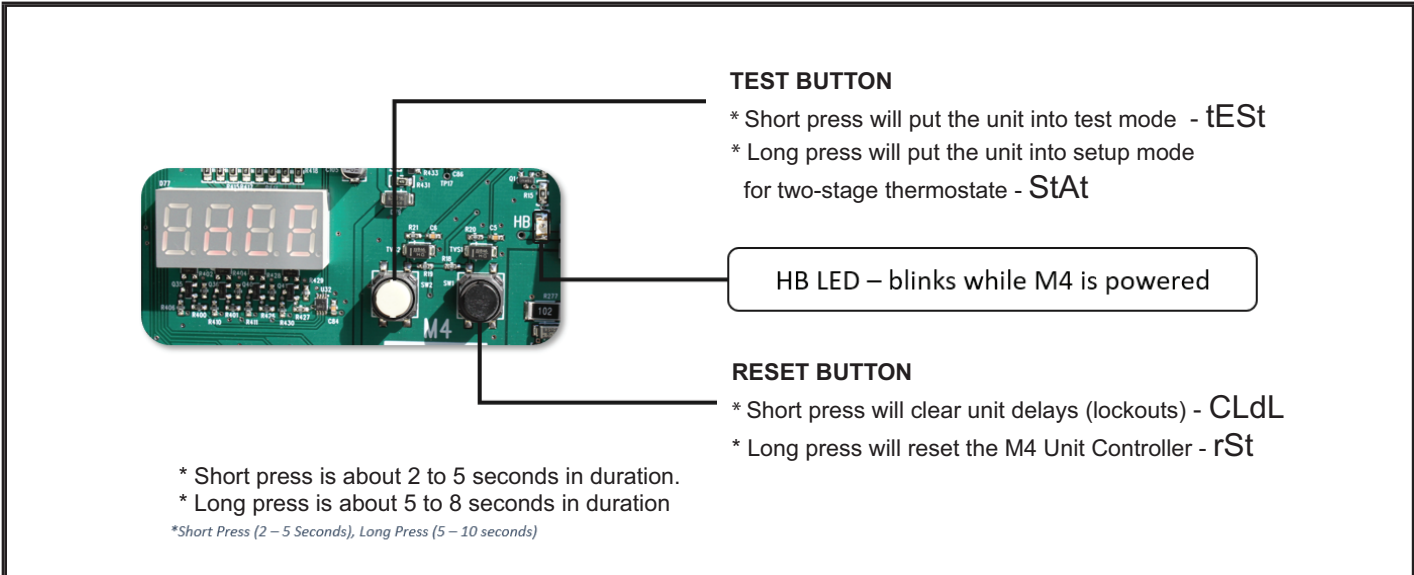

FIGURE 18

TABLE 2

UNIT CONTROLLER PUSHBUTTON CODES

Code	Cause	Action
CLdL	Black Button: Short Press	Clear Delays
rSt	Black Button: Long Press	Reset
tEst	White Button: Short Press	TSTAT Test
StAt	White Button: Long Press (In Pre-Install state)	TSTAT Override
tEst	White Button: Long Press (NOT in Pre-Install State)	TSTAT Test
Short Press : 2 to 5 seconds. Long Press : 5 to 8 seconds.		

Blower Operation and Adjustments

⚠ IMPORTANT

Three phase scroll compressors must be phased sequentially for correct compressor and blower rotation. Follow "COOLING START-UP" section of installation instructions to ensure proper compressor and blower operation.

A-Blower Operation

Refer to the Unit Controller Setup Guide to energize blower. Use the mobile service app menu; see:

**RTU MENU>COMPONENT TEST>BLOWER>
START TEST**

⚠ WARNING

- 1- Make sure that unit is installed in accordance with the installation instructions and applicable codes.
- 2- Inspect all electrical wiring, both field and factory-installed, for loose connections. Tighten as required.
- 3- Check to ensure that refrigerant lines do not rub against the cabinet or against other refrigerant lines.
- 4- Check voltage at disconnect switch. Voltage must be within range listed on nameplate. If not, consult power company and have voltage condition corrected before starting unit.
- 5- Make sure filters are new and in place before start-up.

Direct-drive motor may not immediately stop when power is interrupted to the Unit Controller. Disconnect unit power before opening the blower compartment. The Controller's digital inputs must be used to shut down the blower. See Unit Controller manual for operation sequences.

B-Determining Unit CFM

- 1 - The following measurements must be made with air filters in place.
- 2 - With all access panels in place, measure static pressure external to unit (from supply to return). Blower performance data is based on static pressure readings taken in locations shown in FIGURE 19.

NOTE - Static pressure readings can vary if not taken where shown.

- 3 - Measure the indoor blower wheel RPM.
- 4 - Referring to the Blower Data tables, use static pressure and RPM readings to determine unit CFM. Use the Accessory Air Resistance tables when installing units with any of the options or accessories listed. Refer to TABLE 3 for minimum airflow when electric heat is installed.

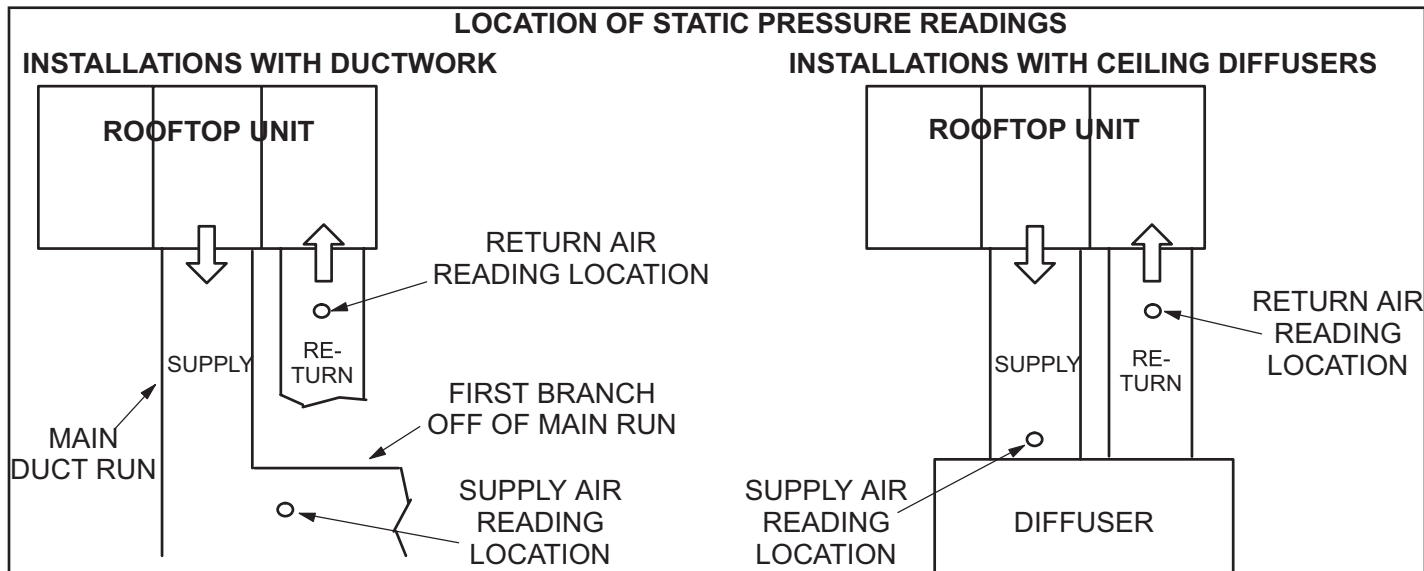

FIGURE 19

5 - From the mobile service app, use **TEST & BALANCE > BLOWER** menu to modify the following blower parameters:

- **HEATING HIGH CFM**
This is the percentage of torque for blower heating speed.
- **HEATING LOW CFM**
This is the percentage of torque for blower heating low speed on single phase gas heating units only.
- **COOLING HIGH CFM**
This is the percentage of torque for blower cooling high speed. For 024 units, this is the only cooling speed.
- **COOLING LOW CFM**
This is the percentage of torque for blower cooling low speed (036, 048, and 060 units only) and vent speed for standard static blowers (all units).
- **VENTILATION CFM**
This is the percentage of torque for high static blower ventilation speed.

Minimum Airflow for Electric Heat				
Size	kW Size	Minimum CFM		
		Direct Drive	Belt Drive Downflow	Belt Drive Horizontal
All Models	5	600	N/A	N/A
	7.5	600	1,050	1200
	10	600	N/A	N/A
	15	1100	1250	1350
	22.5	1600	1750	1800

C-Adjusting Unit CFM

The supply CFM can be adjusted by changing Unit Controller settings. Refer to TABLE 4 for menu paths and default settings. Record any CFM changes on the parameter settings label located on the inside of the compressor access panel.

IMPORTANT - The default value for Cooling Low CFM is lower than a traditional single- or two-speed blower. If operating the unit with a 2 or 3-stage controller (2 or 3-stage thermostat, DDC controller, etc.), it is recommended to increase the Cooling Low CFM default value to a suitable level for part load cooling (typically 60% of full load CFM).

TABLE 4
DIRECT DRIVE PARAMETER SETTINGS - 581102-01

024-072 Parameter Settings		
Parameter	Field Setting	Description
NOTE - Any changes to Smoke CFM setting must be adjusted before the other CFM settings. Use SETTINGS > RTU OPTIONS > EDIT PARAMETERS = 12 for EBM, 6 for ECM		
BLOWER SMOKE CFM	%	Percentage of torque for blower smoke speed
SETUP > TEST & BALANCE > BLOWER		
BLOWER HEATING HIGH CFM	%	Percentage of torque for blower heating high speed.
BLOWER HEATING LOW CFM	%	Percentage of torque for blower heating low speed (P volt gas heat only).
BLOWER COOLING HIGH CFM	%	Percentage of torque for blower cooling high speed.
BLOWER COOLING LOW CFM	%	Percentage of torque for blower cooling low speed and vent speed for standard static blowers.
BLOWER VENTILATION CFM	%	Percentage of torque for high static blower ventilation speed.
SETUP > TEST & BALANCE > DAMPER		
BLOWER HIGH CFM DAMPER POS %	%	Minimum damper position for high speed blower operation. Default 0%.
BLOWER LOW CFM DAMPER POS %	%	Minimum damper position for low speed blower operation. Default 0%.
POWER EXHAUST DAMPER POS %	%	Minimum damper position for low power exhaust operation. Default 50%.
SETTINGS > RTU OPTIONS > EDIT PARAMETERS = 216		
POWER EXHAUST DEADBAND	%	Deadband % for power exhaust operation. Default 10%.
SETTINGS > RTU OPTIONS > EDIT PARAMETERS = 10 (Applies to Thermostat Mode ONLY)		
FREE COOLING STAGE-UP DELAY	%	Number of seconds to hold blower at low speed before switching to blower at high speed. Default 300 seconds.

Installer - Record any parameter changes under "Field Setting" column. Settings need to be recorded by installer for use when Unit Controller is replaced or reprogrammed.

BLOWER DATA**0.5 HP | 3 ROW (024, 036)****BLOWER TABLE INCLUDES RESISTANCE FOR BASE UNIT ONLY WITH DRY INDOOR COIL AND AIR FILTERS IN PLACE.**

FOR ALL UNITS ADD:

1- Any factory installed options air resistance (heat section, economizer, etc).

2- Any field installed accessories air resistance (duct resistance, diffuser, etc).

Minimum Air Volume Required for Different Gas Heat Sizes:

Standard Heat - 1075 cfm; Medium Heat - 1150 cfm; High Heat - 1500 cfm

See page 26 for wet coil and options/accessory air resistance data.

DOWNFLOW

External Static Pressure in. w.g.		Percentage of Total Motor Torque																									
		20%			30%			40%			50%			60%			70%			80%			90%			100%	
Cfm	RPM	Watts	Cfm	RPM	Watts	Cfm	RPM	Watts	Cfm	RPM	Watts	Cfm	RPM	Watts	Cfm	RPM	Watts	Cfm	RPM	Watts	Cfm	RPM	Watts	Cfm	RPM		
0	1101	120	494	1328	196	578	1555	272	662	1728	374	731	1901	475	800	2023	580	852	2145	684	903	2292	854	970	2348	942	998
0.1	1002	99	541	1241	180	620	1479	260	698	1662	366	763	1845	471	827	1976	579	876	2106	687	924	2268	865	987	2334	958	1013
0.2	918	88	589	1167	173	663	1416	257	736	1608	366	796	1800	475	856	1938	586	902	2076	697	947	2249	880	1006	2324	978	1031
0.3	848	86	638	1106	174	706	1364	261	774	1564	373	830	1763	485	886	1907	599	929	2051	712	972	2234	899	1028	2316	1000	1052
0.4	790	92	688	1056	183	751	1321	273	814	1527	387	866	1733	501	918	1882	617	958	2031	732	998	2221	921	1051	2307	1024	1074
0.5	742	105	738	1015	197	796	1287	289	854	1498	405	902	1709	520	950	1862	637	988	2014	754	1025	2208	944	1076	2296	1048	1099
0.6	703	124	788	981	217	841	1258	310	894	1473	427	939	1688	543	984	1843	660	1019	1998	777	1053	2194	968	1101	2281	1071	1124
0.7	670	146	838	952	240	887	1233	334	935	1451	451	976	1668	568	1017	1826	685	1050	1982	801	1082	2177	991	1128	2260	1092	1151
0.8	642	172	888	927	266	932	1211	360	975	1431	477	1013	1650	593	1051	1807	709	1081	1963	825	1111	2155	1012	1155	2233	1109	1178
0.9	618	200	937	904	294	976	1190	387	1015	1410	502	1050	1629	617	1084	1785	732	1112	1940	846	1140	2127	1029	1182	1233	1191	1257
1.0	595	229	985	882	321	1020	1168	413	1054	1387	526	1086	1605	639	1117	1758	752	1143	1911	864	1169	2090	1042	1209	1257	1304	1371
1.1	---	---	---	---	---	---	1144	437	1092	1360	548	1120	1576	659	1148	1725	769	1173	1874	878	1197	2043	1049	1236	1288	1336	1394
1.2	---	---	---	---	---	---	1115	458	1129	1328	566	1154	1540	674	1179	1685	780	1202	1829	886	1225	1985	1049	1262	1314	1362	1410
1.3	---	---	---	---	---	---	1080	475	1163	1288	579	1186	1496	683	1208	1634	785	1230	1772	887	1251	1913	1042	1288	1336	1384	1432
1.4	---	---	---	---	---	---	1037	487	1196	1239	587	1216	1441	686	1236	1572	783	1256	1703	880	1275	1826	1042	1312	1360	1408	1456

HORIZONTAL

External Static Pressure in. w.g.		Percentage of Total Motor Torque																										
		20%			30%			40%			50%			60%			70%			80%			90%			100%		
Cfm	RPM	Watts	Cfm	RPM	Watts	Cfm	RPM	Watts	Cfm	RPM	Watts	Cfm	RPM	Watts	Cfm	RPM	Watts	Cfm	RPM	Watts	Cfm	RPM	Watts	Cfm	RPM	Watts	Cfm	RPM
0	1077	113	502	1282	175	585	1486	237	668	1670	363	746	1854	489	823	1993	623	884	2131	757	944	2216	882	995	2268	926	1009	
0.1	1016	109	546	1227	172	624	1437	234	701	1626	361	775	1814	488	848	1956	623	906	2098	757	964	2194	887	1011	2242	928	1026	
0.2	962	111	591	1177	174	663	1392	236	735	1585	364	805	1777	492	874	1923	627	930	2069	762	985	2175	895	1029	2218	935	1044	
0.3	913	118	636	1133	181	703	1352	244	770	1548	372	836	1744	500	902	1893	636	955	2042	772	1007	2157	907	1048	2196	945	1063	
0.4	868	130	682	1092	193	744	1315	256	806	1515	384	868	1714	512	930	1866	648	980	2018	784	1030	2139	922	1069	2231	973	1071	
0.5	827	146	728	1054	209	785	1281	271	842	1484	399	901	1687	526	959	1841	663	1007	1995	799	1054	2121	938	1090	2257	999	1099	
0.6	789	165	775	1019	227	827	1249	288	879	1455	416	934	1660	543	988	1816	679	1034	1972	815	1079	2102	955	1113	2267	1024	1113	
0.7	752	185	821	986	247	869	1219	308	916	1427	435	967	1634	562	1018	1792	698	1061	1949	833	1104	2081	972	1136	2297	1034	1136	
0.8	718	208	867	954	268	910	1189	328	953	1399	455	1000	1608	581	1047	1767	716	1088	1925	851	1129	2058	989	1160	2323	1055	1160	
0.9	684	231	913	922	290	951	1160	349	989	1371	475	1033	1581	600	1077	1741	734	1116	1900	868	1154	2031	1004	1185	2349	1069	1185	
1.0	---	---	---	---	---	---	1129	369	1025	1341	494	1066	1553	618	1106	1713	751	1143	1872	884	1179	2001	1017	1209	2375	1099	1209	
1.1	---	---	---	---	---	---	1097	388	1060	1310	511	1098	1522	634	1135	1682	766	1170	1841	898	1204	1966	1028	1233	2401	1113	1233	
1.2	---	---	---	---	---	---	1063	405	1095	1276	527	1129	1488	648	1163	1647	779	1196	1806	909	1228	1925	1034	1257	2427	1124	1257	
1.3	---	---	---	---	---	---	1026	420	1128	1239	540	1159	1451	659	1190	1609	788	1221	1767	917	1252	1879	1036	1281	2453	1130	1281	
1.4	---	---	---	---	---	---	985	431	1160	1197	548	1188	1409	665	1216	1566	793	1245	1723	920	1274	1825	1033	1304	2479	1130	1304	

BLOWER DATA

1.0 HP | 3 ROW (048)

BLOWER TABLE INCLUDES RESISTANCE FOR BASE UNIT ONLY WITH DRY INDOOR COIL AND AIR FILTERS IN PLACE.

FOR ALL UNITS ADD:

- 1- Any factory installed options air resistance (heat section, economizer, etc).
- 2- Any field installed accessories air resistance (duct resistance, diffuser, etc).

Minimum Air Volume Required for Different Gas Heat Sizes:

Standard Heat - 1075 cfm; Medium Heat - 1150 cfm; High Heat - 1500 cfm

See page 26 for wet coil and options/accessory air resistance data.

DOWNFLOW

External Static Pressure in. w.g.	Percentage of Total Motor Torque																												
	20%			30%			40%			50%			60%			70%			80%			90%			100%				
	Cfm	RPM	Watts	Cfm	RPM	Watts	Cfm	RPM	Watts	Cfm	RPM	Watts	Cfm	RPM	Watts	Cfm	RPM	Watts	Cfm	RPM	Watts	Cfm	RPM	Watts	Cfm	RPM	Watts	Cfm	RPM
0	1115	124	488	1344	200	572	1573	276	655	1747	377	724	1920	477	792	2041	581	844	2161	684	896	2304	852	964	2354	936	992	992	
0.1	1012	101	536	1253	181	614	1493	261	691	1677	366	755	1860	471	819	1990	578	868	2119	685	916	2277	860	980	2339	951	1006	1006	
0.2	926	88	584	1177	172	656	1427	256	728	1619	365	788	1811	473	848	1949	583	894	2086	693	939	2256	873	999	2328	969	1024	1024	
0.3	854	86	634	1113	173	701	1372	260	767	1572	371	823	1772	482	878	1916	595	921	2059	707	963	2240	891	1019	2319	991	1043	1043	
0.4	794	91	684	1061	181	746	1328	270	807	1535	383	859	1741	496	910	1890	611	950	2038	725	989	2226	913	1042	2311	1014	1065	1065	
0.5	745	104	734	1019	195	791	1292	286	847	1504	401	895	1715	515	942	1868	631	979	2020	747	1016	2214	936	1066	2301	1039	1089	1089	
0.6	704	122	785	983	215	837	1262	307	888	1478	423	932	1693	538	976	1849	654	1011	2004	770	1045	2201	960	1092	2288	1063	1114	1114	
0.7	671	145	836	954	238	883	1237	331	929	1456	447	969	1674	562	1009	1831	678	1041	1988	794	1073	2185	983	1118	2270	1085	1140	1140	
0.8	643	171	886	929	264	928	1215	357	969	1435	472	1006	1655	587	1043	1813	703	1073	1970	818	1103	2164	1005	1145	2246	1104	1168	1168	
0.9	619	199	935	907	291	973	1194	383	1010	1415	498	1043	1635	612	1076	1792	726	1104	1948	840	1132	2138	1024	1173	2212	1119	1196	1196	
1.0	596	228	983	884	319	1016	1172	410	1049	1392	523	1079	1612	635	1109	1766	747	1135	1920	859	1161	2104	1038	1200	2200	1200	1200	1200	
1.1	---	---	---	---	---	---	---	---	---	---	---	---	---	---	---	---	---	---	---	---	---	---	---	---	---	---	---	---	---
1.2	---	---	---	---	---	---	---	---	---	---	---	---	---	---	---	---	---	---	---	---	---	---	---	---	---	---	---	---	---
1.3	---	---	---	---	---	---	---	---	---	---	---	---	---	---	---	---	---	---	---	---	---	---	---	---	---	---	---	---	---
1.4	---	---	---	---	---	---	---	---	---	---	---	---	---	---	---	---	---	---	---	---	---	---	---	---	---	---	---	---	---

HORIZONTAL

External Static Pressure in. w.g.	Percentage of Total Motor Torque																														
	20%			30%			40%			50%			60%			70%			80%			90%			100%						
	Cfm	RPM	Watts	Cfm	RPM	Watts	Cfm	RPM	Watts	Cfm	RPM	Watts	Cfm	RPM	Watts	Cfm	RPM	Watts	Cfm	RPM	Watts	Cfm	RPM	Watts	Cfm	RPM	Watts	Cfm	RPM	Watts	Cfm
0	1087	111	493	1304	184	579	1520	257	665	1689	368	738	1857	478	810	1972	588	864	2087	698	918	2196	844	975	2283	925	1000	1000			
0.1	1021	104	537	1246	180	618	1470	255	699	1646	368	768	1821	480	837	1941	592	888	2061	704	938	2179	852	992	2255	926	1017	1017			
0.2	961	102	582	1193	181	658	1425	259	734	1607	373	799	1789	487	864	1914	601	912	2039	714	960	2163	864	1012	2231	932	1034	1034			
0.3	906	106	628	1145	186	699	1384	266	769	1572	382	831	1759	498	892	1889	613	938	2018	728	984	2149	879	1033	2209	941	1053	1053			
0.4	855	113	674	1101	196	740	1347	278	806	1540	396	864	1732	513	921	1866	629	965	1999	744	1008	2134	896	1054	2177	954	1077	1077			
0.5	808	125	720	1060	209	781	1312	293	842	1509	412	896	1706	530	950	1843	646	992	1980	762	1033	2119	915	1077	2155	974	1101	1101			
0.6	764	139	766	1022	225	823	1279	310	879	1481	430	930	1682	549	980	1821	666	1019	1960	782	1058	2102	935	1101	2134	974	1125	1125			
0.7	722	155	812	985	242	864	1247	328	916	1452	449	964	1657	569	1011	1799	686	1048	1940	803	1084	2084	955	1125	2155	974	1125	1125			
0.8	682	172	858	949	260	906	1216	348	953	1424	469	997	1632	589	1041	1776	706	1076	1919	823	1111	2063	974	1150	2177	974	1125	1125			
0.9	643	191	903	914	279	946	1185	367	989	1396	489	1030	1606	610	1071	1751	727	1104	1895	843	1137	2039	992	1175	2209	992	1125	1125			
1.0	---	---	---	---	---	---	---	---	---	---	---	---	---	---	---	---	---	---	---	---	---	---	---	---	---	---	---	---	---		
1.1	---	---	---	---	---	---	---	---	---	---	---	---	---	---	---	---	---	---	---	---	---	---	---	---	---	---	---	---	---		
1.2	---	---	---	---	---	---	---	---	---	---	---	---	---	---	---	---	---	---	---	---	---	---	---	---	---	---	---	---	---		
1.3	---	---	---	---	---	---	---	---	---	---	---	---	---	---	---	---	---	---	---	---	---	---	---	---	---	---	---	---	---		
1.4	---	---	---	---	---	---	---	---	---	---	---	---	---	---	---	---	---	---	---	---	---	---	---	---	---	---	---	---	---		

BLOWER DATA

1.0 HP | 4 ROW (060)

BLOWER TABLE INCLUDES RESISTANCE FOR BASE UNIT ONLY WITH DRY INDOOR COIL AND AIR FILTERS IN PLACE.

FOR ALL UNITS ADD:

1- Any factory installed options air resistance (heat section, economizer, etc).

2- Any field installed accessories air resistance (duct resistance, diffuser, etc).

Minimum Air Volume Required for Different Gas Heat Sizes:

Standard Heat - 1075 cfm; Medium Heat - 1150 cfm; High Heat - 1500 cfm

See page 26 for wet coil and options/accessory air resistance data.

DOWNFLOW

External Static Pressure in. w.g.	Percentage of Total Motor Torque																																			
	20%				30%				40%				50%				60%				70%				80%				90%				100%			
	Cfm	RPM	Watts	RPM	Cfm	RPM	Watts	RPM	Cfm	RPM	Watts	RPM	Cfm	RPM	Watts	RPM	Cfm	RPM	Watts	RPM	Cfm	RPM	Watts	RPM	Cfm	RPM	Watts	RPM	Cfm	RPM	Watts	RPM	Cfm	RPM	Watts	RPM
0	1101	120	494	1328	196	578	1555	272	662	1728	374	731	1901	475	800	2023	580	852	2145	684	903	2292	854	970	2348	942	998									
0.1	1002	99	541	1241	180	620	1479	260	698	1662	366	763	1845	471	827	1976	579	876	2106	687	924	2268	865	987	2334	958	1013									
0.2	918	88	589	1167	173	663	1416	257	736	1608	366	796	1800	475	856	1938	586	902	2076	697	947	2249	880	1006	2324	978	1031									
0.3	848	86	638	1106	174	706	1364	261	774	1564	373	830	1763	485	886	1907	599	929	2051	712	972	2234	899	1028	2316	1000	1052									
0.4	790	92	688	1056	183	751	1321	273	814	1527	387	866	1733	501	918	1882	617	958	2031	732	998	2221	921	1051	2307	1024	1074									
0.5	742	105	738	1015	197	796	1287	289	854	1498	405	902	1709	520	950	1862	637	988	2014	754	1025	2208	944	1076	2296	1048	1099									
0.6	703	124	788	981	217	841	1258	310	894	1473	427	939	1688	543	984	1843	660	1019	1998	777	1053	2194	968	1101	2281	1071	1124									
0.7	670	146	838	952	240	887	1233	334	935	1451	451	976	1668	568	1017	1826	685	1050	1982	801	1082	2177	991	1128	2260	1092	1151									
0.8	642	172	888	927	266	932	1211	360	975	1431	477	1013	1650	593	1051	1807	709	1081	1963	825	1111	2155	1012	1155	2233	1109	1178									
0.9	618	200	937	904	294	976	1190	387	1015	1410	502	1050	1629	617	1084	1785	732	1112	1940	846	1140	2127	1029	1182	1251	1288										
1.0	595	229	985	882	321	1020	1168	413	1054	1387	526	1086	1605	639	1117	1758	752	1143	1911	864	1169	2090	1042	1209	1288											
1.1	572	258	1034	859	348	1068	1144	437	1092	1360	548	1120	1576	659	1148	1725	769	1173	1874	878	1197	2043	1049	1236	1312											
1.2	552	287	1081	836	375	1112	1115	458	1129	1328	566	1154	1540	674	1179	1685	780	1202	1829	886	1225	1985	1049	1262	1331											
1.3	532	316	1128	813	402	1163	1080	475	1163	1288	579	1186	1496	683	1208	1634	785	1230	1772	887	1251	1913	1042	1288	1350											
1.4	512	345	1174	790	428	1206	1037	487	1196	1239	587	1216	1441	686	1236	1572	783	1256	1703	880	1275	1826	1024	1312	1379											

HORIZONTAL

External Static Pressure in. w.g.	Percentage of Total Motor Torque																																			
	20%				30%				40%				50%				60%				70%				80%				90%				100%			
	Cfm	RPM	Watts	RPM	Cfm	RPM	Watts	RPM	Cfm	RPM	Watts	RPM	Cfm	RPM	Watts	RPM	Cfm	RPM	Watts	RPM	Cfm	RPM	Watts	RPM	Cfm	RPM	Watts	RPM	Cfm	RPM	Watts	RPM	Cfm	RPM	Watts	RPM
0	1077	113	502	1282	175	585	1486	237	668	1670	363	746	1854	489	823	1993	623	884	2131	757	944	2216	882	995	2268	926	1009									
0.1	1016	109	546	1227	172	624	1437	234	701	1626	361	775	1814	488	848	1956	623	906	2098	757	964	2194	887	1011	2242	928	1026									
0.2	962	111	591	1177	174	663	1392	236	735	1585	364	805	1777	492	874	1923	627	930	2069	762	985	2175	895	1029	2218	935	1044									
0.3	913	118	636	1133	181	703	1352	244	770	1548	372	836	1744	500	902	1893	636	955	2042	772	1007	2157	907	1048	2196	945	1063									
0.4	868	130	682	1092	193	744	1315	256	806	1515	384	868	1714	512	930	1866	648	980	2018	784	1030	2139	922	1069	2251	985	1082									
0.5	827	146	728	1054	209	785	1281	271	842	1484	399	901	1687	526	959	1841	663	1007	1995	799	1054	2121	938	1090	2281	1024	1103									
0.6	789	165	775	1019	227	827	1249	288	879	1455	416	934	1660	543	988	1816	679	1034	1972	815	1079	2102	955	1113	2311	1052	1122									
0.7	752	185	821	986	247	869	1219	308	916	1427	435	967	1634	562	1018	1792	698	1061	1949	833	1104	2081	972	1136	2341	1081	1151									
0.8	718	208	867	954	268	910	1189	328	953	1399	455	1000	1608	581	1047	1767	716	1088	1925	851	1129	2058	989	1160	2371	1110	1180									
0.9	684	231	913	922	290	951	1160	349	989	1371	475	1033	1581	600	1077	1741	734	1116	1900	868	1154	2031	1004	1185	2401	1139	1209									
1.0	652	254	959	899	313	1000	1129	369	1025	1341	494	1066	1553	618	1106	1713	751	1143	1872	884	1179	2001	1017	1209	2431	1168	1233									
1.1	622	277	1006	878	336	1048	1097	388	1060	1310	511	1098	1522	634	1135	1682	766	1170	1841	898	1204	1966	1028	1233	2461	1197	1257									
1.2	592	300	1054	857	359	1095	1063	405	1095	1276	527	1129	1488	648	1163	1647	779	1196	1806	909	1228	1925	1034	1257	2491	1226	1281									
1.3	562	323	1102	836	382	1142	1026	420	1128	1239	540	1159	1451	659	1190	1609	788	1221	1767	917	1252	1879	1036	1281	2521	1255	1304									
1.4	532	346	1149	815	405	1189	985	431	1160	1197	548	1188	1409	665	1216	1566	793	1245	1723	920	1274	1825	1033	1304	2551	1280	1339									

BLOWER DATA

1.5 HP | 3 ROW (036, 048)

BLOWER TABLE INCLUDES RESISTANCE FOR BASE UNIT ONLY WITH DRY INDOOR COIL AND AIR FILTERS IN PLACE.

See page 26 for wet coil and options/accessory air resistance data.

DOWNFLOW

Total Air cfm	Total Static Pressure - in. w.c.																									
	0.1		0.2		0.3		0.4		0.5		0.6		0.7		0.8		0.9		1.0		1.1		1.2		1.3	
	RPM	Watts	RPM	Watts	RPM	Watts	RPM	Watts	RPM	Watts	RPM	Watts	RPM	Watts	RPM	Watts	RPM	Watts	RPM	Watts	RPM	Watts	RPM	Watts	RPM	Watts
400	718	19	803	41	878	60	---	---	---	---	---	---	---	---	---	---	---	---	---	---	---	---	---	---	---	---
600	845	50	929	72	1008	92	1080	111	1149	127	1226	129	1307	126	1386	124	---	---	---	---	---	---	---	---	---	---
800	971	79	1057	101	1138	123	1214	143	1286	160	1362	168	1439	173	1510	181	1574	197	1630	220	1681	250	1731	279	1779	307
1000	1136	113	1215	135	1293	157	1367	177	1438	196	1510	209	1579	222	1642	239	1697	263	1747	293	1796	324	1844	353	1890	379
1200	1335	151	1406	172	1476	193	1544	213	1611	232	1675	250	1735	272	1788	299	1834	332	1878	368	1923	400	1970	428	2015	454
1400	1560	177	1617	204	1675	231	1732	257	1788	283	1841	310	1891	339	1936	371	1978	405	2019	439	2063	469	2108	496	2152	522
1600	1742	245	1792	278	1842	311	1892	344	1940	376	1988	406	2035	434	2080	461	2125	486	2169	513	2213	541	2256	570	2297	601
1800	1922	330	1970	363	2017	395	2064	426	2110	457	2155	485	2200	512	2244	539	2287	568	2328	600	2369	634	2408	671	2447	708
2000	2112	405	2158	438	2202	471	2246	503	2289	536	2331	568	2373	602	2413	640	2452	681	2490	723	2527	766	2564	809	2599	851
2200	2305	493	2347	531	2389	569	2429	608	2469	648	2508	691	2546	737	2582	784	2619	832	2654	878	2690	923	2724	965	2758	1007
2400	2499	617	2539	660	2578	704	2615	748	2652	794	2688	841	2722	890	2757	939	2791	986	2825	1031	2858	1075	2891	1117	2923	1158
2600	2697	773	2733	818	2769	864	2803	911	2837	957	2871	1005	2903	1052	2936	1099	2968	1143	3000	1186	3031	1228	3062	1270	3092	1311
2800	2896	944	2929	990	2962	1036	2993	1082	3025	1128	3056	1173	3087	1216	3118	1259	3147	1300	3177	1341	3206	1382	3236	1423	3264	1463
3000	3093	1115	3124	1160	3154	1205	3184	1249	3214	1293	3243	1335	3272	1376	3300	1416	3327	1456	3355	1495	3383	1536	3410	1576	3437	1615

Total Air cfm	Total Static Pressure - in. w.g.																							
	1.4		1.5		1.6		1.7		1.8		1.9		2.0											
	RPM	Watts	RPM	Watts	RPM	Watts	RPM	Watts	RPM	Watts	RPM	Watts	RPM	Watts										
800	1826	333	---	---	---	---	---	---	---	---	---	---	---	---										
1000	1935	403	1979	424	2021	444	2064	464	2106	485	2149	509	2191	533										
1200	2058	476	2100	498	2142	518	2184	541	2226	565	2267	592	2308	619										
1400	2194	548	2235	574	2275	601	2316	629	2356	658	2395	689	2433	720										
1600	2337	632	2377	665	2415	698	2453	733	2490	768	2527	803	2563	839										
1800	2484	746	2521	785	2557	824	2592	863	2627	902	2661	942	2695	981										
2000	2634	894	2668	935	2701	977	2735	1018	2768	1058	2802	1099	2834	1139										
2200	2790	1049	2823	1090	2855	1130	2887	1170	2919	1210	2952	1250	2984	1289										
2400	2954	1200	2986	1240	3017	1280	3048	1320	3080	1360	3111	1399	3142	1437										
2600	3123	1351	3153	1391	3184	1431	3215	1470	3245	1509	3276	1548	3306	1586										
2800	3294	1502	3323	1542	3352	1580	3382	1619	3412	1658	3442	1696	3472	1734										
3000	3464	1653	3492	1691	3520	1729	3549	1767	3578	1805	3608	1844	3638	1882										

BLOWER DATA

1.5 HP | 3 ROW (036, 048)

BLOWER TABLE INCLUDES RESISTANCE FOR BASE UNIT ONLY WITH DRY INDOOR COIL AND AIR FILTERS IN PLACE.

See page 26 for wet coil and options/accessory air resistance data.

DOWNFLOW

Total Air cfm	Total Static Pressure - in. w.c.																															
	0.1		0.2		0.3		0.4		0.5		0.6		0.7		0.8		0.9		1.0		1.1		1.2		1.3							
	RPM	Watts	RPM	Watts	RPM	Watts	RPM	Watts	RPM	Watts	RPM	Watts	RPM	Watts	RPM	Watts	RPM	Watts	RPM	Watts	RPM	Watts	RPM	Watts	RPM	Watts						
400	708	16	793	37	872	53	1000	82	1077	95	1149	107	1221	109	1365	148	1434	154	1497	163	1555	179	1607	200	1656	226	1704	254	---	---	---	
600	835	46	918	65	1000	82	1077	95	1149	107	1221	109	1365	148	1434	154	1497	163	1555	179	1607	200	1656	226	1704	254	---	---	---	---		
800	981	75	1064	92	1144	109	1221	124	1294	139	1365	148	1434	154	1497	163	1555	179	1607	200	1656	226	1704	254	---	---	---	---	---	---		
1000	1166	105	1241	124	1315	141	1387	159	1454	176	1520	191	1582	207	1638	227	1689	252	1737	279	1783	308	1829	335	1873	362	---	---	---	---	---	
1200	1374	142	1440	162	1506	182	1569	203	1630	224	1687	246	1739	271	1787	299	1832	330	1876	361	1920	391	1964	419	2007	444	---	---	---	---	---	
1400	1591	183	1647	209	1701	235	1755	263	1806	291	1854	320	1899	351	1942	382	1984	412	2026	442	2068	469	2110	496	2153	520	---	---	---	---	---	
1600	1778	258	1827	290	1876	323	1923	355	1970	386	2015	416	2059	444	2102	470	2144	494	2185	519	2227	545	2268	572	2309	600	---	---	---	---	---	
1800	1973	352	2018	383	2063	415	2107	445	2151	476	2194	504	2237	531	2279	557	2319	584	2359	613	2397	645	2435	679	2471	713	---	---	---	---	---	
2000	2182	437	2224	468	2265	499	2306	531	2346	563	2385	596	2424	630	2461	666	2496	705	2530	745	2564	786	2598	826	2631	866	---	---	---	---	---	
2200	2388	540	2426	576	2464	613	2500	651	2536	691	2571	731	2605	774	2637	819	2668	863	2700	907	2732	949	2764	990	2795	1029	---	---	---	---	---	
2400	2589	679	2624	719	2658	761	2691	803	2724	846	2756	890	2786	935	2816	980	2846	1025	2876	1068	2907	1109	2937	1149	2967	1188	---	---	---	---	---	
2600	2787	845	2819	887	2850	930	2881	973	2911	1017	2941	1060	2970	1104	2999	1147	3028	1189	3057	1230	3087	1270	---	---	---	---	---	---	---	---	---	
2800	2983	1021	3013	1063	3042	1106	3070	1149	3099	1191	---	---	---	---	---	---	---	---	---	---	---	---	---	---	---	---	---	---	---	---	---	---

Total Air cfm	Total Static Pressure - in. w.g.																																
	1.4		1.5		1.6		1.7		1.8		1.9		2.0																				
	RPM	Watts	RPM	Watts	RPM	Watts	RPM	Watts	RPM	Watts	RPM	Watts	RPM	Watts																			
800	---	---	---	---	---	---	---	---	---	---	---	---	---	---	---	---	---	---	---	---	---	---	---	---	---	---	---	---	---	---	---	---	
1000	1916	386	1957	408	1998	428	2037	447	2077	465	---	---	---	---	---	---	---	---	---	---	---	---	---	---	---	---	---	---	---	---	---	---	
1200	2049	468	2089	490	2128	510	2168	529	2207	549	2246	569	2285	591	---	---	---	---	---	---	---	---	---	---	---	---	---	---	---	---	---	---	
1400	2194	543	2235	565	2274	588	2313	611	2350	637	2387	664	2423	694	---	---	---	---	---	---	---	---	---	---	---	---	---	---	---	---	---	---	
1600	2349	627	2387	657	2423	688	2457	722	2490	757	2522	793	2554	830	---	---	---	---	---	---	---	---	---	---	---	---	---	---	---	---	---	---	
1800	2506	749	2539	787	2571	825	2602	864	2632	903	2662	942	2692	981	---	---	---	---	---	---	---	---	---	---	---	---	---	---	---	---	---	---	
2000	2663	906	2694	945	2725	985	2755	1024	2785	1063	2815	1101	2845	1138	---	---	---	---	---	---	---	---	---	---	---	---	---	---	---	---	---	---	
2200	2826	1068	2857	1107	2887	1146	2916	1184	2946	1221	2975	1259	3005	1296	---	---	---	---	---	---	---	---	---	---	---	---	---	---	---	---	---	---	
2400	2997	1227	3027	1266	3056	1304	3085	1342	---	---	---	---	---	---	---	---	---	---	---	---	---	---	---	---	---	---	---	---	---	---	---	---	---
2600	---	---	---	---	---	---	---	---	---	---	---	---	---	---	---	---	---	---	---	---	---	---	---	---	---	---	---	---	---	---	---	---	---
2800	---	---	---	---	---	---	---	---	---	---	---	---	---	---	---	---	---	---	---	---	---	---	---	---	---	---	---	---	---	---	---	---	---

BLOWER DATA

1.5 HP | 4 ROW (060)

BLOWER TABLE INCLUDES RESISTANCE FOR BASE UNIT ONLY WITH DRY INDOOR COIL AND AIR FILTERS IN PLACE.

See page 26 for wet coil and options/accessory air resistance data.

DOWNFLOW

Total Air cfm	Total Static Pressure - in. w.c.																												
	0.1		0.2		0.3		0.4		0.5		0.6		0.7		0.8		0.9		1.0		1.1		1.2		1.3				
	RPM	Watts	RPM	Watts	RPM	Watts	RPM	Watts	RPM	Watts	RPM	Watts	RPM	Watts	RPM	Watts	RPM	Watts	RPM	Watts	RPM	Watts	RPM	Watts	RPM	Watts			
400	720	20	805	41	880	60	1083	112	1152	128	1229	130	1310	126	1389	125	1514	183	1578	198	1634	222	1684	252	1734	281	1783	309	
600	849	51	933	73	1011	93	1083	112	1152	128	1229	130	1310	126	1389	125	1514	183	1578	198	1634	222	1684	252	1734	281	1783	309	
800	978	81	1064	103	1145	124	1220	144	1291	162	1367	170	1443	175	1514	183	1578	198	1634	222	1684	252	1734	281	1783	309	328	1896	382
1000	1147	116	1225	138	1302	159	1376	179	1446	198	1517	211	1586	224	1648	242	1703	266	1753	296	1801	327	1849	356	1896	382	408	2021	458
1200	1347	154	1418	175	1487	196	1555	216	1620	235	1684	253	1743	275	1795	302	1841	336	1884	373	1930	405	1976	433	2021	458	480	2156	537
1400	1571	182	1629	209	1686	236	1742	262	1798	288	1850	315	1899	346	1943	380	1984	417	2025	453	2068	485	2113	512	2156	537	560	2302	621
1600	1753	252	1803	286	1853	318	1902	351	1951	383	1998	415	2043	447	2087	478	2130	508	2173	539	2216	568	2259	595	2302	621	640	2458	714
1800	1935	339	1983	371	2030	403	2076	434	2122	465	2167	495	2210	524	2253	554	2295	586	2337	618	2378	650	2418	682	2458	714	730	2614	855
2000	2127	415	2172	448	2217	481	2260	513	2303	546	2345	579	2385	614	2425	653	2464	693	2503	734	2541	774	2578	814	2614	855	870	2770	1023
2200	2321	507	2363	545	2404	583	2444	623	2484	664	2522	707	2560	753	2596	801	2632	848	2667	895	2703	939	2737	981	2936	1176	1190	3107	1330
2400	2516	635	2556	679	2594	723	2631	767	2668	813	2703	861	2737	909	2772	958	2805	1005	2839	1050	2872	1093	2905	1135	2936	1176	1190	3107	1330
2600	2715	796	2751	841	2786	887	2820	933	2854	980	2887	1027	2919	1074	2952	1120	2983	1164	3015	1207	3046	1249	3077	1290	3107	1330	1350	3280	1485
2800	2915	970	2947	1016	2979	1062	3011	1107	3042	1152	3073	1197	3104	1240	1282	1328	3164	1323	3193	1364	3222	1404	3251	1445	3280	1485	1500	3453	1638
3000	3112	1142	3142	1187	3172	1232	3202	1276	3232	1319	3261	1361	3289	1401	3317	1441	3344	1480	3371	1520	3399	1560	3426	1600	3453	1638	1650	3626	1811

Total Air cfm	Total Static Pressure - in. w.g.													
	1.4		1.5		1.6		1.7		1.8		1.9		2.0	
	RPM	Watts	RPM	Watts	RPM	Watts	RPM	Watts	RPM	Watts	RPM	Watts	RPM	Watts
800	1830	335	1983	426	2026	446	2068	466	2111	488	2154	512	2196	536
1000	1940	405	2106	501	2148	522	2190	544	2232	569	2273	595	2314	623
1200	2064	480	2241	584	2282	608	2323	634	2363	664	2402	694	2440	726
1400	2199	560	2384	675	2424	706	2462	740	2498	776	2535	811	2571	848
1600	2344	647	2533	788	2568	829	2602	872	2636	914	2671	953	2705	992
1800	2497	749	2681	941	2714	986	2746	1030	2779	1072	2812	1112	2845	1152
2000	2648	898	2835	1105	2867	1145	2899	1186	2931	1225	2964	1265	2995	1303
2200	2803	1064	2999	1258	3031	1298	3062	1337	3093	1377	3124	1415	3156	1454
2400	2968	1217	3168	1411	3199	1450	3229	1489	3260	1528	3290	1566	3321	1604
2600	3138	1371	3338	1563	3368	1602	3398	1640	3428	1678	3458	1717	3488	1755
2800	3309	1524	3508	1715	3537	1752	3566	1790	3595	1828	3625	1866	3655	1904
3000	3481	1677	3698	1904	3727	1944	3756	1994	3825	1981	3854	1994	3923	2032

BLOWER DATA

1.5 HP | 4 ROW (060)

BLOWER TABLE INCLUDES RESISTANCE FOR BASE UNIT ONLY WITH DRY INDOOR COIL AND AIR FILTERS IN PLACE.

See page 26 for wet coil and options/accessory air resistance data.

DOWNFLOW

Total Air cfm	Total Static Pressure - in. w.c.																									
	0.1		0.2		0.3		0.4		0.5		0.6		0.7		0.8		0.9		1.0		1.1		1.2		1.3	
	RPM	Watts	RPM	Watts	RPM	Watts	RPM	Watts	RPM	Watts	RPM	Watts	RPM	Watts	RPM	Watts	RPM	Watts	RPM	Watts	RPM	Watts	RPM	Watts	RPM	Watts
400	711	16	796	38	---	---	---	---	---	---	---	---	---	---	---	---	---	---	---	---	---	---	---	---	---	---
600	840	47	924	66	1006	83	1083	96	1154	107	1226	109	---	---	---	---	---	---	---	---	---	---	---	---	---	---
800	990	76	1072	94	1153	111	1230	126	1301	140	1372	148	1441	155	1503	165	1560	181	1612	203	1661	229	---	---	---	---
1000	1179	108	1253	126	1326	144	1397	161	1464	178	1530	194	1590	210	1646	231	1696	255	1744	283	1790	312	1836	340	1880	365
1200	1388	146	1454	166	1519	186	1582	207	1641	228	1697	251	1749	276	1797	305	1842	336	1885	367	1929	397	1973	424	2016	450
1400	1606	189	1661	216	1715	242	1768	270	1818	298	1866	328	1911	358	1953	390	1995	420	2037	449	2079	476	2121	503	2163	527
1600	1794	268	1842	301	1890	333	1938	364	1984	396	2029	426	2073	453	2115	479	2157	503	2199	528	2240	553	2281	581	2321	609
1800	1991	364	2035	395	2079	426	2123	456	2167	486	2210	515	2252	541	2294	568	2334	596	2374	625	2412	657	2448	692	2484	727
2000	2202	451	2242	482	2283	513	2323	545	2363	577	2402	611	2440	646	2477	683	2512	722	2546	763	2579	804	2613	844	2645	884
2200	2408	559	2446	596	2483	633	2520	672	2555	712	2590	753	2623	796	2655	841	2686	885	2717	928	2748	970	2780	1010	2812	1050
2400	2609	703	2644	744	2678	786	2711	829	2744	872	2776	916	2806	961	2835	1006	2865	1050	2895	1092	2925	1133	2955	1172	2985	1212
2600	2808	874	2840	916	2871	959	2902	1003	2932	1046	2961	1090	2990	1133	3019	1176	3048	1217	3077	1257	3106	1297	3135	1336	3164	1374
2800	3006	1054	3035	1096	3064	1139	3092	1181	3121	1223	3149	1265	3177	1305	3205	1344	3234	1383	3262	1421	3290	1460	3317	1498	3345	1536
3000	3202	1228	3229	1270	3257	1312	3284	1353	3312	1394	3339	1433	3366	1472	3393	1509	3419	1547	3446	1584	3472	1622	3499	1660	3525	1698

Total Air cfm	Total Static Pressure - in. w.g.													
	1.4		1.5		1.6		1.7		1.8		1.9		2.0	
	RPM	Watts	RPM	Watts	RPM	Watts	RPM	Watts	RPM	Watts	RPM	Watts	RPM	Watts
800	---	---	---	---	---	---	---	---	---	---	---	---	---	---
1000	1923	389	1964	411	2004	431	2043	450	2083	468	---	---	---	---
1200	2057	473	2097	494	2136	514	2176	534	2215	553	2254	574	2293	596
1400	2205	549	2245	571	2284	594	2322	618	2360	644	2396	672	2432	702
1600	2360	637	2398	667	2434	699	2468	733	2501	768	2532	805	2563	842
1800	2519	763	2552	801	2583	840	2614	879	2644	918	2674	957	2704	995
2000	2677	924	2708	963	2739	1003	2769	1041	2799	1080	2829	1118	2859	1155
2200	2842	1089	2873	1127	2902	1166	2932	1203	2962	1241	2991	1278	3021	1315
2400	3015	1250	3044	1289	3074	1327	3103	1364	3132	1402	3162	1439	3192	1476
2600	3192	1412	3221	1450	3250	1488	3279	1525	3308	1562	3337	1599	3367	1635
2800	3372	1574	3400	1611	3428	1648	3456	1685	3485	1721	3514	1758	3543	1794
3000	3552	1735	3578	1772	3605	1808	3633	1844	3660	1880	3689	1916	3717	1952

BLOWER DATA

FACTORY INSTALLED OPTIONS/FIELD INSTALLED ACCESSORY AIR RESISTANCE - in. w.g.

Air Volume cfm	Wet Indoor Coil		Economizer	Electric Heat	Filters		
	024, 036, 048	060			MERV 8	MERV 13	MERV 16
800	0.01	0.01	0.04	0.01	0.04	0.05	0.04
1000	0.02	0.01	0.04	0.03	0.04	0.07	0.05
1200	0.02	0.01	0.04	0.06	0.04	0.07	0.05
1400	0.03	0.02	0.04	0.09	0.04	0.07	0.06
1600	0.04	0.03	0.04	0.12	0.04	0.07	0.08
1800	0.05	0.04	0.05	0.15	0.05	0.07	0.09
2000	0.06	0.05	0.05	0.18	0.05	0.08	0.10
2200	0.08	0.06	0.05	0.20	0.05	0.08	0.11
2400	0.09	0.07	0.05	0.22	0.05	0.08	0.12

POWER EXHAUST FAN PERFORMANCE

Return Air System Static Pressure in. w.g.	Air Volume Exhausted cfm
0.00	2000
0.05	1990
0.10	1924
0.15	1810
0.20	1664
0.25	1507
0.30	1350
0.35	1210

CEILING DIFFUSERS AIR RESISTANCE (in. w.g.)

Air Volume - cfm	RTD11-95S Step-Down Diffuser			FD9-65S Flush Diffuser	RTD11-95S Step-Down Diffuser			FD11-95S Flush Diffuser
	2 Ends Open	1 Side & 2 Ends Open	All Ends & Sides Open		2 Ends Open	1 Side & 2 Ends Open	All Ends & Sides Open	
800	0.15	0.13	0.11	0.11	---	---	---	---
1000	0.19	0.16	0.14	0.14	---	---	---	---
1200	0.25	0.20	0.17	0.17	---	---	---	---
1400	0.33	0.26	0.20	0.20	---	---	---	---
1600	0.43	0.32	0.20	0.24	---	---	---	---
1800	0.56	0.40	0.30	0.30	0.13	0.11	0.09	0.09
2000	0.73	0.50	0.36	0.36	0.15	0.13	0.11	0.10
2200	0.95	0.63	0.44	0.44	0.18	0.15	0.12	0.12
2400	---	----	---	---	0.21	0.18	0.15	0.14

CEILING DIFFUSER AIR THROW DATA

Air Volume - cfm	1 Effective Throw - ft.	
	RTD11-95S	FD11-95S
800	10 - 17	14 - 18
1000	10 - 17	15 - 20
1200	11 - 18	16 - 22
1400	12 - 19	17 - 24
1600	12 - 20	18 - 25
1800	13 - 21	20 - 28
2000	14 - 23	21 - 29
2200	16 - 25	22 - 30

¹ Effective throw based on terminal velocities of 75 ft. per minute.

Refrigerant Leak Detection System

A-System Test

- 1 - Initiate Refrigerant Leak Detection System Test by using the following mobile service app menu path:

RTU MENU > COMPONENT TEST > LEAK DETECTION > START TEST

- 2 - Ensure that indoor blower, outdoor fan, and combustion air blower (LGT only) are energized.

Start-Up

IMPORTANT

If unit is equipped with a crankcase heater make sure heater is energized 24 hours before unit start-up to prevent compressor damage as a result of slugging.

A-Start-Up

Heating - LHX024 Unit Only

In heat pump heating, 024 units will automatically stage-up for outdoor temperatures below 40°F (for increased performance and efficiency). No external demand is required, this operation is completely automatic. At temperatures above 40°F, compressor will automatically stage-down to maintain operational efficiency.

Heating

- 1 - Set thermostat or temperature control device to initiate a first-stage heating demand.
- 2 - A first-stage heating demand (W1) will energize compressor 1 and outdoor fan.

NOTE - L1 Reversing Valve is de-energized in the heating mode.

LH Units With Optional Electric Heat

An increased heating demand (W2) will energize electric heat. Electric heat is also energized during the defrost cycle to maintain discharge air temperature.

Cooling

NOTE - 024 units are single-speed cooling operation only.

- 1 - Initiate full load cooling operation using the following mobile service app menu path:

RTU MENU > COMPONENT TEST > COOLING > COOLING STAGE 2

- 2 - Units contain one refrigerant circuit.

NOTE - Units are equipped with two-stage compressors.

- 3 - Unit is charged with R-454B refrigerant. See unit rating plate for correct amount of charge.
- 4 - Refer to Refrigerant Charge and Check section for proper method to check refrigerant charge.

B-Three Phase Scroll Compressor Voltage Phasing

Three phase scroll compressors must be phased sequentially to ensure correct compressor and blower rotation and operation. Compressor and blower are wired in phase at the

factory. Power wires are color-coded as follows: line 1-red, line 2-yellow, line 3-blue.

- 1 - Observe suction and discharge pressures and blower rotation on unit start-up.
- 2 - Suction pressure must drop, discharge pressure must rise, and blower rotation must match rotation marking.

If pressure differential is not observed or blower rotation is not correct:

- 3 - Disconnect all remote electrical power supplies.
- 4 - Reverse any two field-installed wires connected to the line side of K1 contactor. Do not reverse wires at blower contactor.

Make sure the connections are tight.

Discharge and suction pressures should operate at their normal start-up ranges.

C-Refrigerant Charge and Check - Fin/Tube Coil

WARNING - Do not exceed nameplate charge under any condition.

This unit is factory charged and should require no further adjustment. If the system requires additional refrigerant, reclaim the charge, evacuate the system, and add required nameplate charge.

NOTE - System charging is not recommended below 60°F (15°C). In temperatures below 60°F (15°C), the charge must be weighed into the system.

If weighing facilities are not available, or to check the charge, use the following procedure:

- 1 - Attach gauge manifolds and operate unit in cooling mode on HIGH SPEED with economizer disabled until system stabilizes (approximately five minutes). Make sure outdoor air dampers are closed.

NOTE - Use mobile service app menu path:

RTU MENU > COMPONENT TEST > COOLING > COOLING STAGE 2

- 2 - Use a thermometer to accurately measure the outdoor ambient temperature.
- 3 - Apply the outdoor temperature to TABLE 5 through TABLE 8 to determine normal operating pressures. Pressures are listed for sea level applications at 80°F dry bulb and 67°F wet bulb return air.
- 4 - Compare the normal operating pressures to the pressures obtained from the gauges. Minor variations in these pressures may be expected due to differences in installations. Significant differences could mean that the system is not properly charged or that a problem exists with some component in the system. **Correct any system problems before proceeding.**
- 5 - If discharge pressure is high, remove refrigerant from the system. If discharge pressure is low, add refrigerant to the system.
 - Add or remove charge in increments.

- Allow the system to stabilize each time refrigerant is added or removed.
- 6 - Use one of the following charge verification methods along with the normal operating pressures to confirm readings.

Charge Verification - Approach Method - AHRI Testing

- 1 - Using the same thermometer, compare liquid temperature to outdoor ambient temperature.
- Approach Temperature = Liquid temperature (at condenser outlet) minus ambient temperature.
- 2 - Approach temperature should be 3.8°F +/- 1 (2.1°C +/- 0.5). An approach temperature greater than this value indicates an under-charge. An approach temperature less than this value indicates an over-charge.

The approach method is not valid for grossly over or undercharged systems. Use TABLE 9 as a guide for typical approach temperatures.

TABLE 5 581329-01 024 NORMAL OPERATING PRESSURES		
Outdoor Coil Entering Air Temp	Discharge ± 10 psig	Suction ± 5 psig
65°F	222	140
75°F	259	68
85°F	301	140
95°F	349	141
100°F	402	143
115°F	464	145

TABLE 6 581330-01 036 NORMAL OPERATING PRESSURES		
Outdoor Coil Entering Air Temp	Discharge ± 10 psig	Suction ± 5 psig
65°F	242	137
75°F	281	138
85°F	325	140
95°F	374	141
100°F	428	143
115°F	489	145

TABLE 7 581331-01 048 NORMAL OPERATING PRESSURES		
Outdoor Coil Entering Air Temp	Discharge ± 10 psig	Suction ± 5 psig
65°F	232	133
75°F	269	135
85°F	310	136
95°F	354	138
100°F	404	140
115°F	457	142

TABLE 8 581332-01 060 NORMAL OPERATING PRESSURES		
Outdoor Coil Entering Air Temp	Discharge ± 10 psig	Suction ± 5 psig
65°F	247	132
75°F	284	133
85°F	324	134
95°F	371	135
100°F	422	137
115°F	476	139

TABLE 9 APPROACH TEMPERATURES	
Unit	Liquid Temperature (At Condenser Outlet) Minus Ambient Temperature
024	5°F +/- 1 (2.8°C +/- 0.5)
036	9°F +/- 1 (5.0°C +/- 0.5)
048	6°F +/- 1 (3.3°C +/- 0.5)
060	8°F +/- 1 (4.4°C +/- 0.5)

Refrigerant Charge R-454B		
Unit	M _c (lbs)	M _c (kg)
LHX024	12.5	5.67
LHX036	12	5.44
LHX048	16.75	7.60
LHX060	15.63	7.09

In addition to conventional charging procedures, the following requirements shall be followed.

- Ensure that contamination of different refrigerants does not occur when using charging equipment. Hoses or lines shall be as short as possible to minimize the amount of refrigerant contained in them.
- Cylinders shall be kept in an appropriate position according to the instructions.
- Ensure that the unit is earth grounded prior to charging the system with refrigerant.
- Label the system when charging is complete (if not already).
- Extreme care shall be taken not to overfill the unit.

Prior to recharging the system, it shall be pressure-tested with the appropriate purging gas. The system shall be leak-tested on completion of charging but prior to commissioning. A follow up leak test shall be carried out prior to leaving the site.

- When removing refrigerant from a system, either for servicing or decommissioning, it is recommended good practice that all refrigerants are removed safely.
- When transferring refrigerant into cylinders, ensure that only appropriate refrigerant recovery cylinders are employed. Ensure that the correct number of cylinders for holding the total system charge is available. All cylinders to be used are designated for the recovered refrigerant and labelled for that refrigerant (i. e. special cylinders for the recovery of

refrigerant). Cylinders shall be complete with pressure-relief valve and associated shut-off valves in good working order. Empty recovery cylinders are evacuated and, if possible, cooled before recovery

- The recovery equipment shall be in good working order with a set of instructions concerning the equipment that is at hand and shall be suitable for the recovery of all appropriate refrigerants including, when applicable, flammable refrigerants. In addition, a set of calibrated weighing scales shall be available and in good working order. Hoses shall be complete with leak-free disconnect couplings and in good condition. Before using the recovery machine, check that it is in satisfactory working order, has been properly maintained and that any associated electrical components are sealed to prevent ignition in the event of a refrigerant release. Consult manufacturer if in doubt.
- The recovered refrigerant shall be returned to the refrigerant supplier in the correct recovery cylinder, and the relevant waste transfer note arranged. Do not mix refrigerants in recovery units and especially not in cylinders.
- If compressors or compressor oils are to be removed, ensure that they have been evacuated to an acceptable level to make certain that flammable refrigerant does not remain within the lubricant. The evacuation process shall be carried out prior to returning the compressor to the suppliers. Only electric heating to the compressor body shall be employed to accelerate this process. When oil is drained from a system, it shall be carried out safely.

NOTE - System charging is not recommended below 60°F (15°C). In temperatures below 60°F (15°C), the charge must be weighed into the system.

If weighing facilities are not available, or to check the charge, use the following procedure:

- 1 - Make sure outdoor coil is clean. Attach gauge manifolds and operate unit at full CFM in cooling mode with economizer disabled until system stabilizes (approximately five minutes). Make sure all outdoor air dampers are closed.
- 2 - Compare the normal operating pressures to the pressures obtained from the gauges. Check unit components if there are significant differences.
- 3 - Measure the outdoor ambient temperature and the suction pressure. Refer to the charging curve to determine a target liquid temperature.

NOTE - Pressures are listed for sea level applications.

- 4 - Use the same thermometer to accurately measure the liquid temperature (in the outdoor section).
 - If measured liquid temperature is higher than the target liquid temperature, add refrigerant to the system.

- If measured liquid temperature is lower than the target liquid temperature, recover some refrigerant from the system..
- 5 - Add or remove charge in increments. Allow the system to stabilize each time refrigerant is added or removed.
 - 6 - Continue the process until measured liquid temperature agrees with the target liquid temperature. Do not go below the target liquid temperature when adjusting charge. Note that suction pressure can change as charge is adjusted.
 - 7 - Example: At 95°F outdoor ambient and a measured suction pressure of 130psig, the target liquid temperature is 97°F. For a measured liquid temperature of 106°F, add charge in increments until measured liquid temperature agrees with the target liquid temperature.

C-Compressor Controls

See unit wiring diagram to determine which controls are used on each unit. Optional controls are identified on wiring diagrams by arrows at junction points.

1 - High Pressure Switch (S4)

The compressor circuit is protected by a high pressure switch which opens at 640 psig \pm 10 psig (4413 kPa \pm 70 kPa) and automatically resets at 475 psig \pm 20 psig (3275kPa \pm 138 kPa).

2 - Low Pressure Switch (S87)

The compressor circuit is protected by a loss of charge switch. Switch opens at 25 psig \pm 5 psig (172 \pm 34 kPa) and automatically resets at 40 psig \pm 5 psig (246 kPa \pm 34 kPa).

3 - Diagnostics Sensors (RT46, RT48)

Two thermistors are located on specific points in the refrigeration circuit. The thermistors provide constant temperature feedback to the Unit Controller to protect the compressor. Thermistors take the place of the freezestat and low ambient pressure switch.

4 - Defrost Controls (RT48, RT17)

Both sensors provide input to the defrost control which cycles defrost. The ambient sensor is located on the inside of the corner mullion on the back of the outdoor coil section. The coil sensor is located on a return bend on the front of the outdoor coil.

5 - Compressor Crankcase Heater (HR1)

Crankcase heater must be energized at all times to prevent compressor damage due to refrigerant migration. Energize crankcase heater 24 hours before unit start-up by setting thermostat so that there is no cooling demand (to prevent compressor from cycling) and apply power to unit.

Defrost Control

The defrost control ensures that the heat pump outdoor coil does not ice excessively during the heating mode. The defrost control uses input from the coil and ambient sensor to issue demand defrost controls from the Unit Controller. If the system fails to calibrate or obtain readings for demand defrost, defrost will run-time at field setting.

Defrost Test or Forced Defrost Option

A TEST option is provided for troubleshooting. The TEST mode may be started at any time using the mobile service app. Defrost mode may be started by entering the Defrost Mode in the Component Test Menu. When defrost is started, unit will run in Defrost Mode for a maximum of 5 minutes or when the outdoor coil reaches 100°F, whichever occurs first.

Diagnostic Sensors

Units are equipped with two factory-installed thermistors (RT46 and RT48) located on different points on the refrigerant circuit.

The thermistors provide the Unit Controller with constant temperature readings of two specific locations on the refrigeration circuit. These temperatures are used as feedback in certain modes of unit operation. In addition, the Unit Controller uses these temperatures to initiate alarms such as loss of condenser or evaporator airflow and loss of charge.

Each thermistor must be specifically placed for proper unit operation and to initiate valid alarms. See TABLE 10 for proper locations.

**TABLE 10
THERMISTOR LOCATION**

Unit	Sensor Yellow	Figure
024, 036, 048, 060 Indoor Coil	RT46	FIGURE 20
024, 036, 048 Outdoor Coil	RT48	FIGURE 21
060 Outdoor Coil	RT48	FIGURE 22

LHX024, 036, 048, 060
EVAPORATOR COIL
RT46

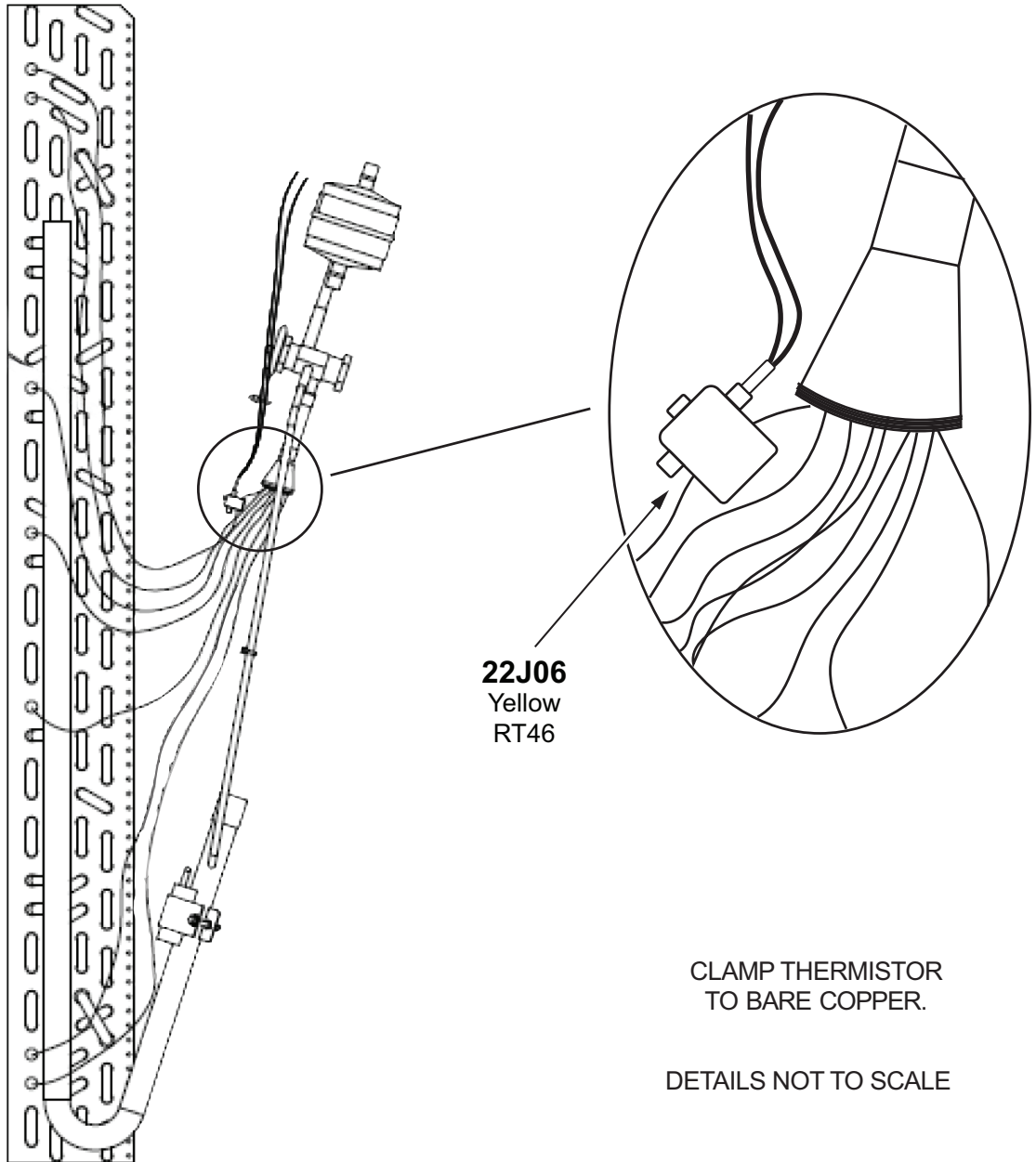
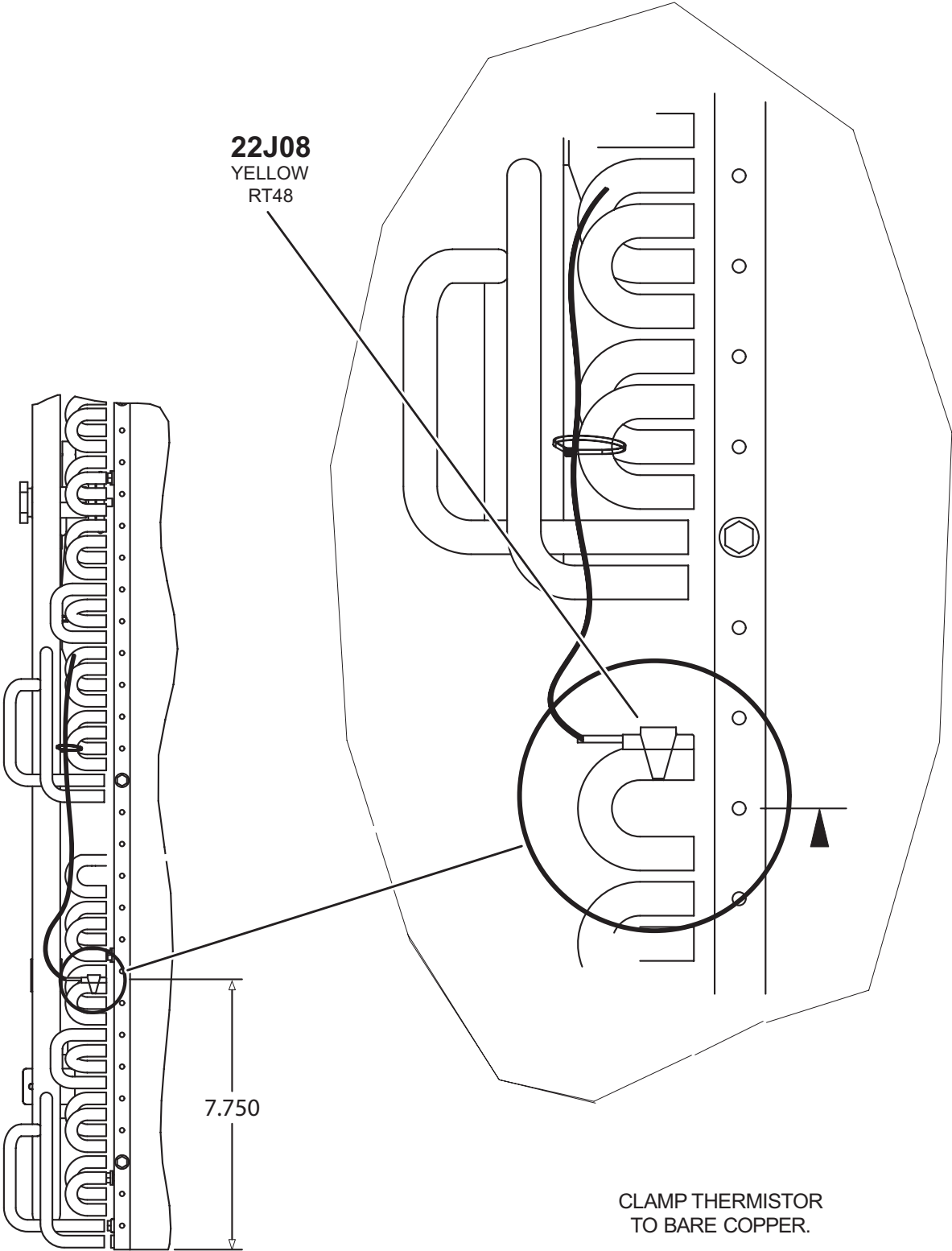

FIGURE 20

LHX024, 036, 048
CONDENSER COIL
RT48



22J08
YELLOW
RT48

7.750

CLAMP THERMISTOR
TO BARE COPPER.

DETAILS NOT TO SCALE

FIGURE 21

LHX060
CONDENSER COIL
RT48

22J08
YELLOW
RT48

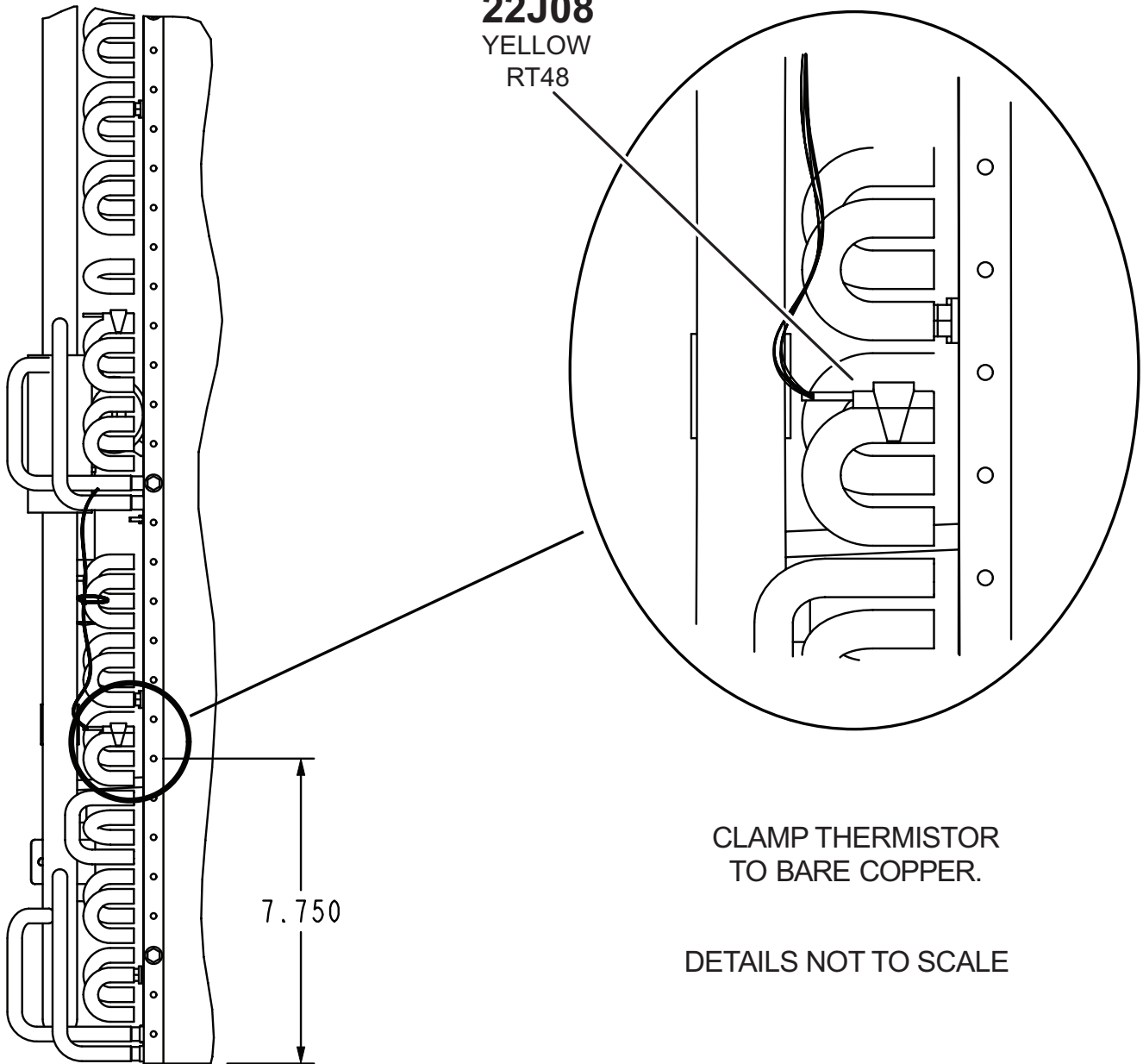

CLAMP THERMISTOR
TO BARE COPPER.

DETAILS NOT TO SCALE

FIGURE 22

RDS Sensors

Units are equipped with factory-installed RDS Sensors located on different points on the unit. The RDS sensors provide the Unit Controller with continuous readings for leaked refrigerant concentration levels and sensor health status (Good or Fault). These readings are used to modify unit operation to disperse the leaked refrigerant and to remove possible ignition sources. In addition, the Unit Controller uses these readings to initiate alarms to alert the operator of a refrigerant leak or faulty sensor(s).

Each sensor must be specifically placed for proper unit operation and to initiate valid alarms. To identify sensor locations see TABLE 11.

TABLE 11

RDS Sensor Figures

Model	Qty.	Type	Figure
LHX024-060	1 sensor	INDOOR SENSOR	FIGURE 23

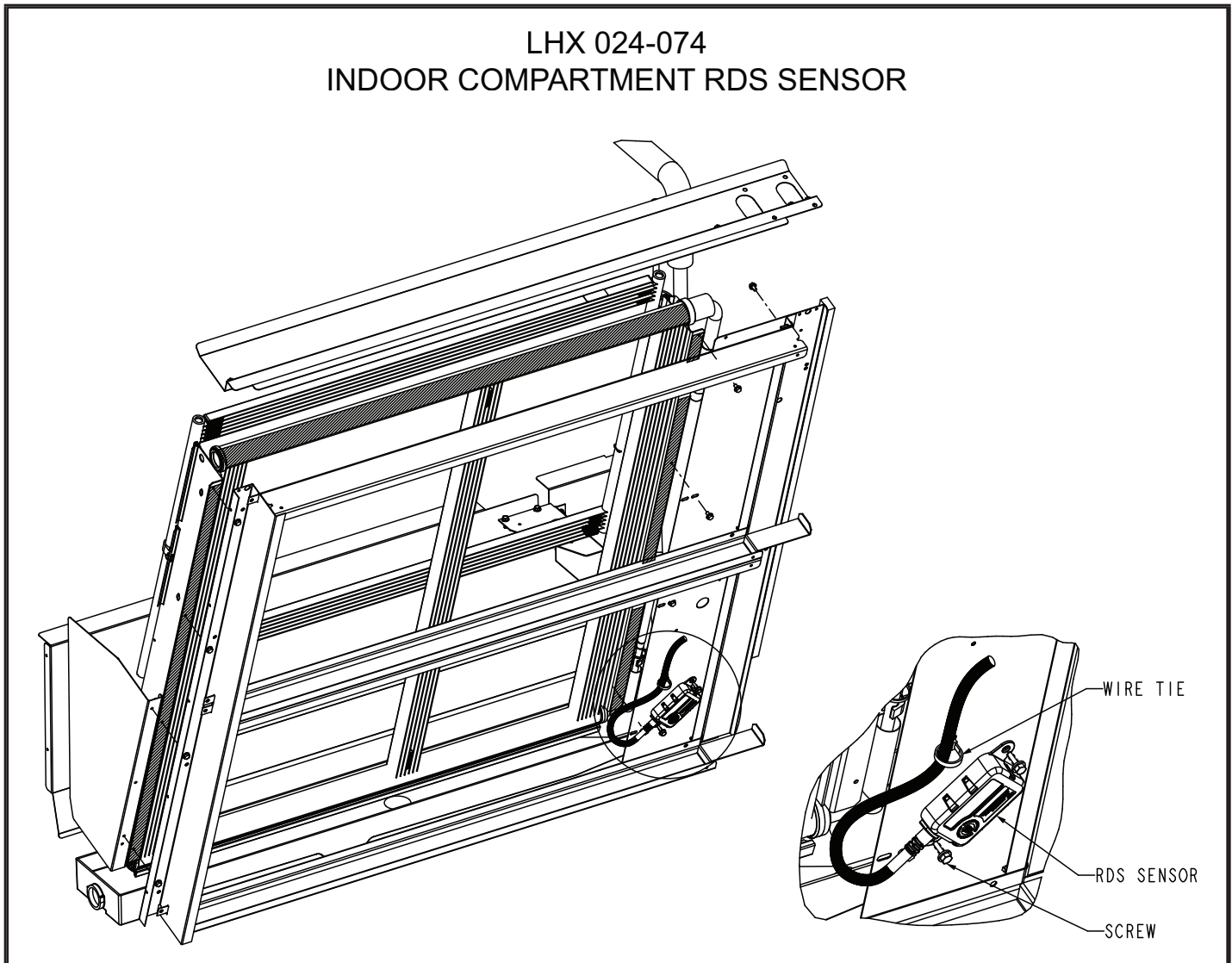

FIGURE 23

Cooling Operation

A-Two-Stage Thermostat

1 - Economizer With Outdoor Air Suitable

Y1 Demand -

Compressor Off
Blower Low
Dampers Modulate

Y2 Demand -

Compressor On (024 units only)
Compressor Low (036-060)
Blower High
Dampers Full Open

NOTE - Compressor is energized after damper has been at full open for three minutes.

2 - No Economizer or Outdoor Air Not Suitable

Y1 Demand -

Compressor On (024 units only)
Compressor Low (036-060)
Blower Low
Dampers Minimum Position

Y2 Demand -

Compressor On (024 units only)
Compressor High (036-060)
Blower High
Dampers Minimum Position

B-Three-Stage Thermostat OR Room Sensor

1 - Economizer With Outdoor Air Suitable

Y1 Demand -

Compressors Off
Blower Low
Dampers Modulate

Y2 Demand -

Compressor On (024 units only)
Compressor Low (036-060)
Blower High
Dampers Full Open

NOTE - Compressor is energized after damper has been at full open for three minutes.

Y3 Demand -

Compressor On (024 units only)
Compressor High (036-060)
Blower High
Dampers Full Open

2 - No Economizer or Outdoor Air Not Suitable

Y1 Demand -

Compressor On (024 units only)
Compressor Low (036-060)
Blower Low
Dampers Minimum Position

Y2 Demand -

Compressor On (024 units only)
Compressor High (036-060)
Blower High
Dampers Minimum Position

Y3 Demand -

Compressor On (024 units only)
Compressor High (036-060)
Blower High
Dampers Minimum Position

High speed compressor cooling operation:

**RTU MENU > COMPONENT TEST > COOLING >
COOLING STAGE 2**

Low speed compressor cooling operation:

**RTU MENU > COMPONENT TEST > COOLING >
COOLING STAGE 1**

NOTE - For 024 units, either menu path will result in single-speed output.

Heating Operation

A-Heat Pump Operation

W1 Demand -

Compressor High
Blower Heating Speed
Reversing Valve De-Energized

W2 Demand (Optional Electric Heat) -

Compressor High Speed
Blower Heating Speed
Reversing Valve De-Energized
Optional Electric Heat Energized

NOTE - Electric heat is also energized during the defrost cycle.

B-Gas Heat Operation

1 - Outdoor Temperature ABOVE Balance Point Setpoint

W1 Demand -

Compressor High
Blower Heating Speed
Reversing Valve De-Energized

W2 Demand -

Compressor Off
Blower Heating Speed
Low Gas Heat Energized

NOTE - Gas heat is also energized during the defrost cycle.

2 - Outdoor Temperature BELOW Balance Point Setpoint

W1 Demand -

Compressor Off
Blower Heating Speed
Low Gas Heat Energized

W2 Demand -

Compressor Off
Blower Heating Speed
High Gas Heat Energized

NOTE - Gas heat is also energized during the defrost cycle.

High speed compressor heating operation:

RTU MENU > COMPONENT TEST > HEATING

Defrost Operation Test:

RTU MENU > COMPONENT TEST > DEFROST

C-Heat Pump Heating - 024 Units Only

In heat pump heating, 024 units will automatically stage-up for outdoor temperatures below 40°F (for increased performance and efficiency). No external demand is required, this operation is completely automatic. At temperatures above 40°F, compressor will automatically stage-down to maintain operational efficiency.

Heat Start-Up

Optional electric heat will stage on and cycle with thermostat demand. See electric heat wiring diagram on unit for sequence of operation.

SCR Electric Heat Controller

Optional factory-installed SCR (A38) will provide small amounts of power to the electric heat elements to efficiently maintain warm duct air temperatures when there is no heating demand. The SCR maintains duct air temperature based on input from a field-provided and installed thermostat (A104) and duct sensor (RT20). SCR is located in the compressor section on the left wall. Use only with a thermostat or specified DDC control system.

Use the instructions provided with the thermostat to set DIP switches as follows: S1 On, S2 Off, S3 Off. Use the instructions provided with the duct sensor to install sensor away from electric element radiant heat and in a location where discharge air is a mixed average temperature.

Once power is supplied to unit, zero SCR as follows:

- 1 - Adjust thermostat (A104) to minimum position.
- 2 - Use a small screwdriver to slowly turn the ZERO potentiometer on the SCR until the LED turns solid red.
- 3 - Very slowly adjust the potentiometer the opposite direction until the LED turns off.

Preventative Maintenance / Repair

IMPORTANT MAINTENANCE / REPAIR SAFETY INSTRUCTIONS

Prior to beginning work on systems containing FLAMMABLE REFRIGERANTS, safety checks are necessary to ensure that the risk of ignition is minimized.

Work shall be undertaken under a controlled procedure to minimize the risk of a flammable gas or vapor being present while the work is being performed.

All maintenance staff and others working in the local area shall be instructed on the nature of work being carried out. Work in confined spaces shall be avoided.

The area shall be checked with an appropriate refrigerant detector prior to and during work, to ensure the technician is aware of potentially toxic or flammable atmospheres. Ensure that the leak detection equipment being used is suitable for use with all applicable refrigerants, i.e. non-sparking, adequately sealed or intrinsically safe.

If any hot work is to be conducted on the refrigerating equipment or any associated parts, appropriate fire extinguishing equipment shall be available to hand. Have a dry powder or CO2 fire extinguisher adjacent to the charging area.

No person carrying out work in relation to a REFRIGERATING SYSTEM which involves exposing any pipe work shall use any sources of ignition in such a manner that it may lead to the risk of fire or explosion. All possible

ignition sources, including cigarette smoking, should be kept sufficiently far away from the site of installation, repairing, removing and disposal, during which refrigerant can possibly be released to the surrounding space. Prior to work taking place, the area around the equipment is to be surveyed to make sure that there are no flammable hazards or ignition risks. "No Smoking" signs shall be displayed.

Where electrical components are being changed, they shall be fit for the purpose and to the correct specification. At all times, the manufacturer's maintenance and service guidelines shall be followed. If in doubt, consult the manufacturer's technical department for assistance.

The following checks shall be applied to installations using **FLAMMABLE REFRIGERANTS**:

- the actual REFRIGERANT CHARGE is in accordance with the room size within which the refrigerant containing parts are installed;
- the ventilation machinery and outlets are operating adequately and are not obstructed;
- if an indirect refrigerating circuit is being used, the secondary circuit shall be checked for the presence of refrigerant;
- marking to the equipment continues to be visible and legible. Markings and signs that are illegible shall be corrected;
- refrigerating pipe or components are installed in a position where they are unlikely to be exposed to any substance which may corrode refrigerant containing components, unless the components are constructed of materials which are inherently resistant to being corroded or are suitably protected against being so corroded.

During repairs to sealed electrical components, the components shall be replaced. Replacement parts shall be in accordance with the manufacturer's specifications.

During repairs to intrinsically safe components, the components must be replaced. Replace components only with parts specified by the manufacturer. Other parts may result in the ignition of refrigerant in the atmosphere from a leak.

The unit should be inspected once a year by a qualified service technician.

⚠ WARNING	
	Electric shock hazard. Can cause injury or death. Before attempting to perform any service or maintenance, turn the electrical power to unit OFF at disconnect switch(es). Unit may have multiple power supplies.

⚠ CAUTION
Label all wires prior to disconnection when servicing controls. Wiring errors can cause improper and dangerous operation. Verify proper operation after servicing.

A-Filters

Units are equipped with temporary filters which must be replaced prior to building occupation. Use four 20 X 20 X 2" (508 X 508 X 51mm) filters. Refer to local codes or appropriate jurisdiction for approved filters.

⚠ WARNING
Units are shipped from the factory with temporary filters. Replace filters before building is occupied. Damage to unit could result if filters are not replaced with approved filters. Refer to appropriate codes.

Approved filters should be checked monthly and replaced when necessary. Take note of air flow direction marking on filter frame when reinstalling filters. See FIGURE 24.

NOTE - Filters must be U.L.C. certified or equivalent for use in Canada.

B-Lubrication

All motors are lubricated at the factory. No further lubrication is required.

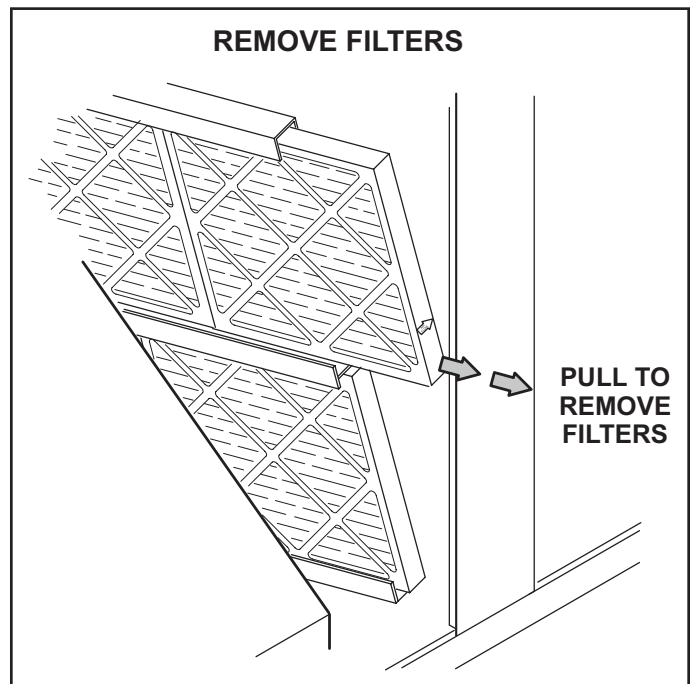

FIGURE 24

C-Evaporator Coil

Inspect and clean coil at beginning of each cooling season. Clean using mild detergent or commercial coil cleaner. Flush coil and condensate drain with water taking care not to get insulation, filters and return air ducts wet.

D-Condenser Coil

Clean condenser coil annually with detergent or commercial coil cleaner and inspect monthly during the cooling season.

Condenser coils are made of single and two formed slabs. On units with two slabs, dirt and debris may become

trapped between the slabs. To clean between slabs, carefully separate coil slabs and wash them thoroughly. See FIGURE 25. Flush coils with water following cleaning.

NOTE - Remove all screws and gaskets prior to cleaning procedure and replace upon completion.

E-Supply Air Blower Wheel

Annually inspect supply air blower wheel for accumulated dirt or dust. Turn off power before attempting to remove access panel or to clean blower wheel.

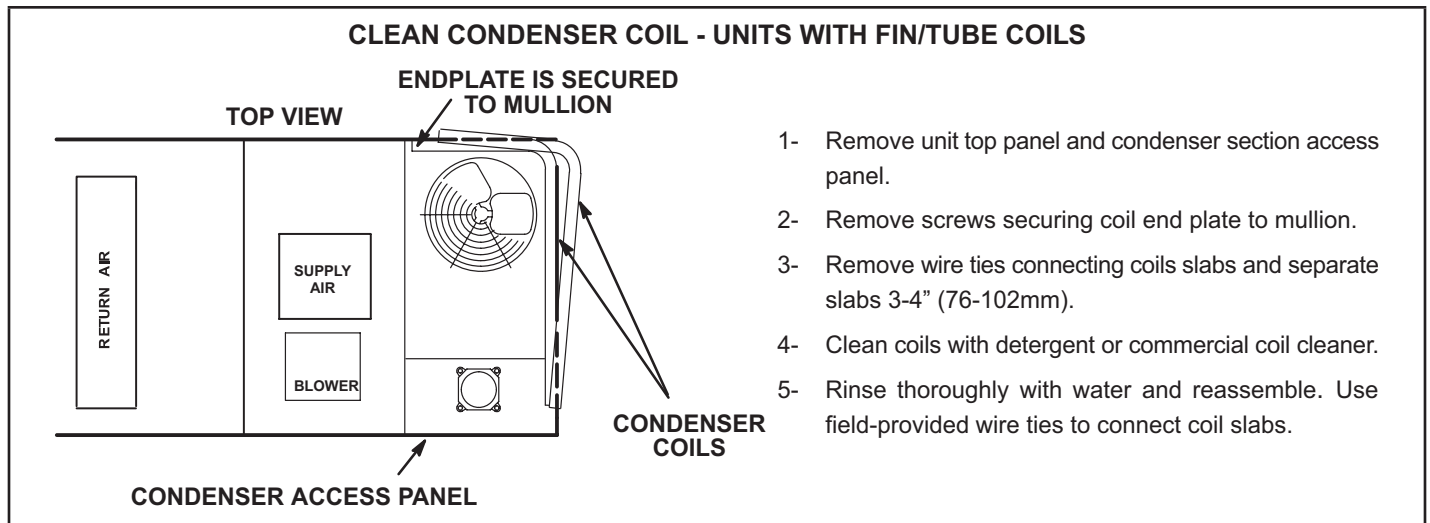

FIGURE 25

F-Needlepoint Bipolar Ionizer (Optional)

The optional, brush-type ionizer produces positive and negative ions to clean air and reduce airborne contaminants. The ionizer was designed to be low maintenance. The device should be checked semi-annually to confirm the brushes are clean for maximum output. The ionizer is located behind on the blower deck to the left of the blower. See FIGURE 27.

- 1 - On the back side of the unit, remove the screw securing the back of the ionizer bracket. See FIGURE 26. Retain the screw to secure the back side of the ionizer bracket.
- 2 - Remove two screws securing the front side of the ionizer bracket and pull out of unit and clean brushes.
- 3 - Replace ionizer in the reverse order it was removed.

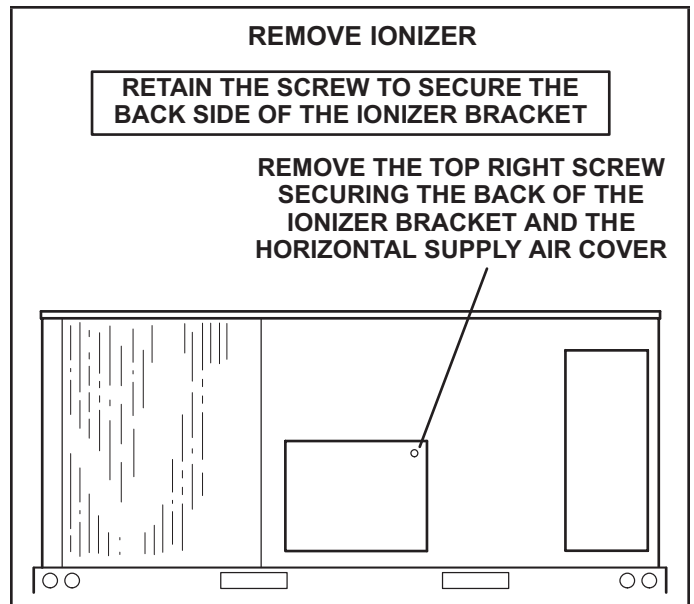

FIGURE 26

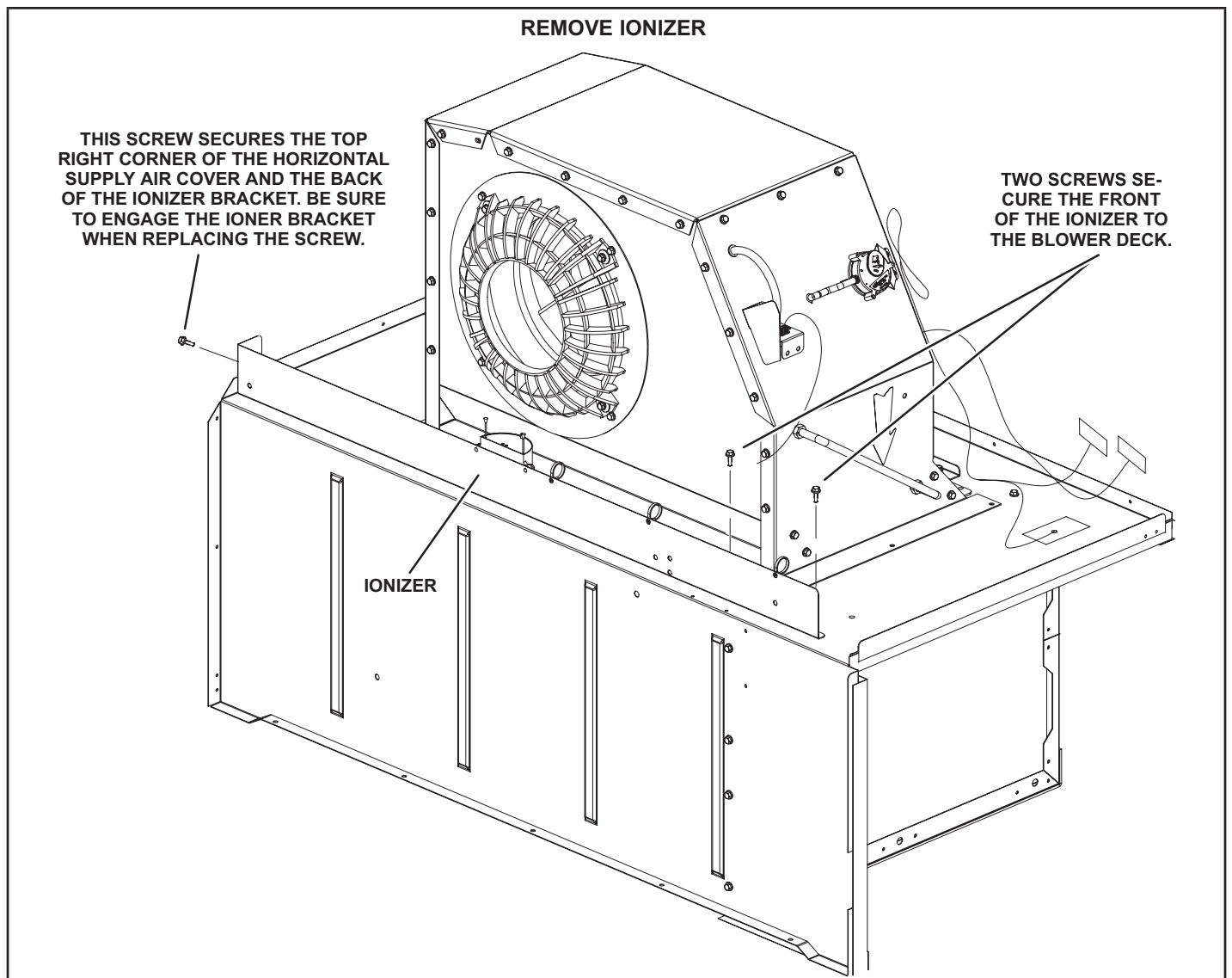

FIGURE 27

G-UVC Light (Optional)

When field-installed, use only UVC Light Kit assembly 106881-01 (21A92) with this appliance.

Factory-Installed UVC Light

When the UVC light is factory installed, the lamp is shipped attached to the filter rack. Remove the lamp and install into the UVC light assembly as shown in steps 2 through 11.

- 1 - Cut wire ties and remove the UVC lamp attached to the filter rack. See FIGURE 28.

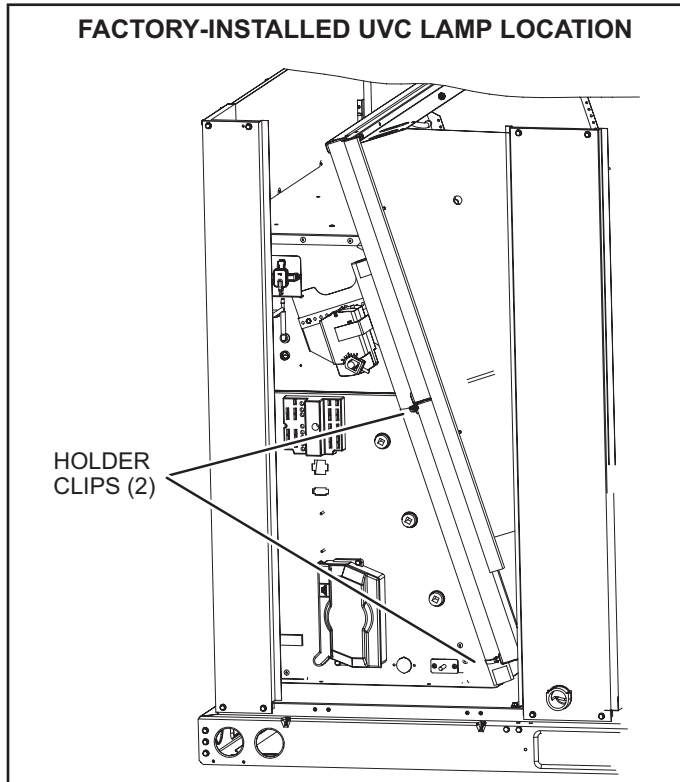

FIGURE 28

Annual Lamp Replacement

⚠ WARNING

Personal Burn Hazard.

Personal injury may result from hot lamps. During replacement, allow lamp to cool for 10 minutes before removing lamp from fixture.

The lamp should be replaced every 12 months, as UVC energy production diminishes over time.

- 1 - Obtain replacement lamp 102337-01 for your germicidal light model.
- 2 - Disconnect power to the rooftop unit before servicing the UVC kit.
- 3 - Open the blower access door.
- 4 - Remove the screw in wire tie from the UVC assembly and disconnect the 4-pin connector from the lamp end.

- 5 - Remove the (2) mounting screws of the UVC assembly. Carefully slide the complete UVC assembly out through the blower access door.
- 6 - Allow 10 minutes before touching the lamps. Then, carefully remove the old lamp from the lamp holder clips.
- 7 - Wear cotton gloves or use a cotton cloth when handling the new lamp. Place the new lamp in the holder clips of the UVC assembly. Verify that the lamp flange at the connector end is sandwiched between the lamp holder clip and the sheet-metal end stop (see FIGURE 29).
- 8 - Carefully place the UVC assembly on the blower deck. Line up the mounting holes on the UVC assembly with the mounting holes on the blower deck. See FIGURE 30. Use the #10 screws provided to attach the UVC assembly in place.
- 9 - Make sure to reapply the black convoluted tubing used to shield electrical wiring in the rooftop unit. Convoluted tubing is provided when the ionizer is factory- or field-installed. However, if there is any concern, aluminum foil tape (not provided) can also be used to cover any exposed component.
- 10 - Close the blower access door.
- 11 - Reconnect power to the rooftop unit.
- 12 - Open the filter access door and look through the view port in the triangular sheet-metal panel to verify that the UVC light is on.

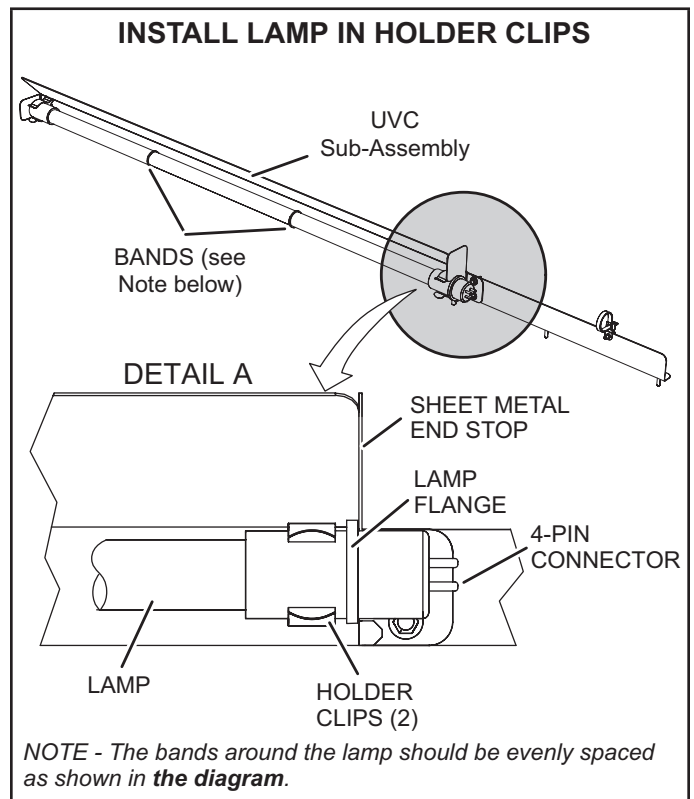

FIGURE 29

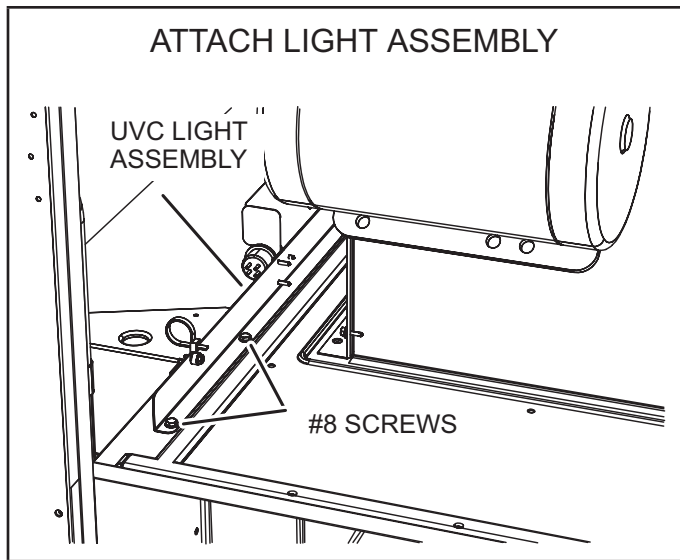

FIGURE 30

Lamp Disposal

Hg-LAMP Contains Mercury - Manage in accordance with local, state and federal disposal laws. Refer to www.lamprecycle.org or call 800-953-6669.

Proper Clean-up Technique in Case of Lamp Breakage

Wear protective gloves, eye wear and mask.

Sweep the broken glass and debris into a plastic bag, seal the bag, and dispose of properly. Contact your local waste management office for proper disposal.

Do not use a vacuum cleaner. Do not incinerate.

Maintenance

- For all maintenance, contact a qualified HVAC technician.
- Read the maintenance instructions before opening unit panels.
- Unintended use of the unit or damage to the unit housing may result in the escape of dangerous UVC radiation. UVC radiation may, even in small doses, cause harm to the eyes and skin.
- Do not operate units that are obviously damaged.
- Do not discard the triangular UVC light shield or any barriers with an ultraviolet radiation symbol.
- Do not override the door interlock switch that interrupts power to the UVC light.
- Do not operate the UVC light outside of the unit.

M-Replacement Fuses

See the following tables for the proper replacement fuse sizes.

ELECTRIC HEAT REPLACEMENT FUSES				
	Electric Heat	Qty.	Rating	
			Amp	Volt
1	E1EH0050N-1P	2	30	250
2	T1/E1EH0075AN1Y	3	25	250
3	E1EH0100N-1P	4	30	250
4	T1/E1EH0150AN1Y	3	50	250
5	T1/E1EH0225AN1Y	6	45	250
6	T1/E1EH0300N-1Y	6	60	250
7	E2EH0300N-1Y	6	60	250
8	K1EH0050A-1P	2	30	250
9	T1/E1EH0075AN1P	2	40	250
10	T1EH0100A-1P	4	30	250
11	T1/E1EH0150AN1P	4	40	250
12	T1/E1EH0225AN1P	6	40	250
13	T1/E1EH0075AN1J	3	15	600
14	T1/E1EH0150AN1J	3	20	600
15	T1/E1EH0225AN1J	3	30	600
16	T1/E1EH0300N-1J	3	40	600
17	T1/E1EH0075AN1G	3	15	600
18	T1/E1EH0150AN1G	3	25	600
19	T1/E1EH0225AN1G	3	35	600
20	T1/E1EH0300N-1G	3	50	600

LHX024																		
Electric Heat Size			7.5 KW								15 KW							
Unit Voltage			208/230V - 1 Ph		208/230V - 3 Ph		460V - 3Ph		575V - 3Ph		208/230V - 1 Ph		208/230V - 3 Ph		460V - 3Ph		575V - 3Ph	
Power Exhaust Option			W/ P.E.	W/O P.E.	W/ P.E.	W/O P.E.	W/ P.E.	W/O P.E.	W/ P.E.	W/O P.E.	W/ P.E.	W/O P.E.	W/ P.E.	W/O P.E.	W/ P.E.	W/O P.E.	W/ P.E.	W/O P.E.
Diagram Key	Class	Blower HP																
F4	RK or K	0.5	40	35	25	25	15	15	15	15	40	35	25	25	15	15	15	15
CB10	-	0.5	50	45	35	30	20	15	15	15	90	90	60	60	30	30	25	25

LHX036																		
Electric Heat Size			7.5 KW								15 KW							
Unit Voltage			208/230V - 1 Ph		208/230V - 3 Ph		460V - 3Ph		575V - 3Ph		208/230V - 1 Ph		208/230V - 3 Ph		460V - 3Ph		575V - 3Ph	
Power Exhaust Option			W/ P.E.	W/O P.E.	W/ P.E.	W/O P.E.	W/ P.E.	W/O P.E.	W/ P.E.	W/O P.E.	W/ P.E.	W/O P.E.	W/ P.E.	W/O P.E.	W/ P.E.	W/O P.E.	W/ P.E.	W/O P.E.
Diagram Key	Class	Blower HP																
F4	RK or K	0.5	40	35	25	25	15	15	15	15	40	35	25	25	15	15	15	15
F4	RK or K	1.0	50	45	35	30	20	15	15	15	-	-	30	30	15	15	15	15
CB10	-	0.5	50	45	35	30	20	15	15	15	90	90	60	60	30	30	25	25
CB10	-	1.0	60	50	35	35	20	20	15	15	100	90	60	60	30	30	25	25

LHX048																		
Electric Heat Size			7.5 KW								15 KW							
Unit Voltage			208/230V - 1 Ph		208/230V - 3 Ph		460V - 3Ph		575V - 3Ph		208/230V - 1 Ph		208/230V - 3 Ph		460V - 3Ph		575V - 3Ph	
Power Exhaust Option			W/ P.E.	W/O P.E.	W/ P.E.	W/O P.E.	W/ P.E.	W/O P.E.	W/ P.E.	W/O P.E.	W/ P.E.	W/O P.E.	W/ P.E.	W/O P.E.	W/ P.E.	W/O P.E.	W/ P.E.	W/O P.E.
Diagram Key	Class	Blower HP																
F4	RK or K	1.0	50	45	35	30	20	15	15	15	50	45	35	30	20	15	15	15
CB10	-	1.0	60	50	35	35	20	20	15	15	100	90	60	60	30	30	25	25

LHX060																		
Electric Heat Size			7.5 KW								15 KW							
Unit Voltage			208/230V - 1 Ph		208/230V - 3 Ph		460V - 3Ph		575V - 3Ph		208/230V - 1 Ph		208/230V - 3 Ph		460V - 3Ph		575V - 3Ph	
Power Exhaust Option			W/ P.E.	W/O P.E.	W/ P.E.	W/O P.E.	W/ P.E.	W/O P.E.	W/ P.E.	W/O P.E.	W/ P.E.	W/O P.E.	W/ P.E.	W/O P.E.	W/ P.E.	W/O P.E.	W/ P.E.	W/O P.E.
Diagram Key	Class	Blower HP																
F4	RK or K	1.0	60	60	40	35	20	15	15	15	60	60	40	35	20	15	15	15
F4	RK or K	2.0	-	-	50	50	25	25	20	20	-	-	50	50	25	25	20	20
CB10	-	1.0	60	60	40	35	20	20	15	15	100	90	60	60	30	30	25	25
CB10	-	2.0	-	-	35	35	20	15	15	15	-	-	60	60	30	30	25	25

LHX060 (continued)

Electric Heat Size			22.5 KW							
Unit Voltage			P Volt		Y Volt		G Volt		J Volt	
Power Exhaust Option			W / P.E.	W / O.P.E.	W / P.E.	W / O.P.E.	W / P.E.	W / O.P.E.	W / P.E.	W / O.P.E.
Diagram Key	Class	Blower HP								
F4	RK or K	1.0	60	60	40	35	20	15	15	15
F4	RK or K	2.0	50	50	50	50	25	25	20	20
CB10	-	1.0	150	150	80	80	45	40	35	35
CB10	-	2.0	80	70	90	80	45	40	35	35

Factory Unit Controller Settings

Use the mobile service app to adjust parameters; menu paths are shown in each table. Refer to the Unit Controller manual provided with each unit.

TABLE 12 and TABLE 13 show factory settings. Record adjusted settings on the label located inside the compressor access panel.

When field installing optional kits and accessories, the Unit Controller must be configured to identify the option before it will function. Refer to FIGURE 31 and FIGURE 32 to determine whether the Unit Controller configuration I.D. must change. To configure the option, use MAIN MENU > SETUP > INSTALL menu path. Press SAVE until CONFIGURATION ID 1 or 2 appears depending on the option installed. Change the appropriate character in the configuration I.D. For example, when an economizer is installed using a single enthalpy sensor, change configuration I.D. 1, the second character, to "S".

TABLE 12
581038

Units With BACnet Settings
RTU Menu > Network Integration > Network Setup Wizard > BACnet MS/TP > See BACnet MAC Address
BACNET MAC ADDRESS:
Units With Room Sensor, CPC/LSE Gateway Settings
RTU Menu > Network Integration > Network Setup Wizard > SBUS > Set SBUS Address
LCONN ADDRESS:

TABLE 13
581037-01

Units With LonTalk Settings
Use menu RTU Menu > Network Integration > Network Setup Wizard
> Set "LONTALK"

Configuration ID 1

1 2 3 4 5 6 7 8

Humiditrol [1]

Not Installed = **N**
 Humiditrol Installed = **H**
 Unconfigured = **U**

Economizer [2]

Not Installed = **N**
 Motorized Outdoor Air
 Damper Only = **M**
 Economizer - Temperature = **T**
 Economizer Global = **G**
 Economizer - Single
 Enthalpy = **S**
 Economizer - Dual Enthalpy = **D**
 Unconfigured = **U**

Power Exhaust [3]

Not Installed = **N**
 Single-Stage = **S**
 Dual-Stage = **D**
 Unconfigured = **U**

Power Exhaust Control [4]

Not Installed = **N**
 Damper Position = **A**
 A34 Pressure Sensor = **C**

[8] Outdoor Air CFM Control

N = Not applicable (for future use)
L = Outdoor Air Control Installed with A24 Sensor set for low range.
M = Outdoor Air Control Installed with A24 Sensor set for medium range.
H = Outdoor Air Control Installed with A24 Sensor set for high range.

[7] System Blower Subtype

N = Not applicable (default)
B = Belt Drive Blower (MODBUS)
L = ECM Direct-Drive Blower (PWM)
H = Direct-Plus Blower (MODBUS)

[6] Blower Variable Frequency Drive Bypass

N = Not Installed
A = Automatic Bypass
M = Manual Bypass
U = Unconfigured

[5] Network Module

N = Not Installed
L = LonTalk (Lennox)

FIGURE 31

Configuration ID 2

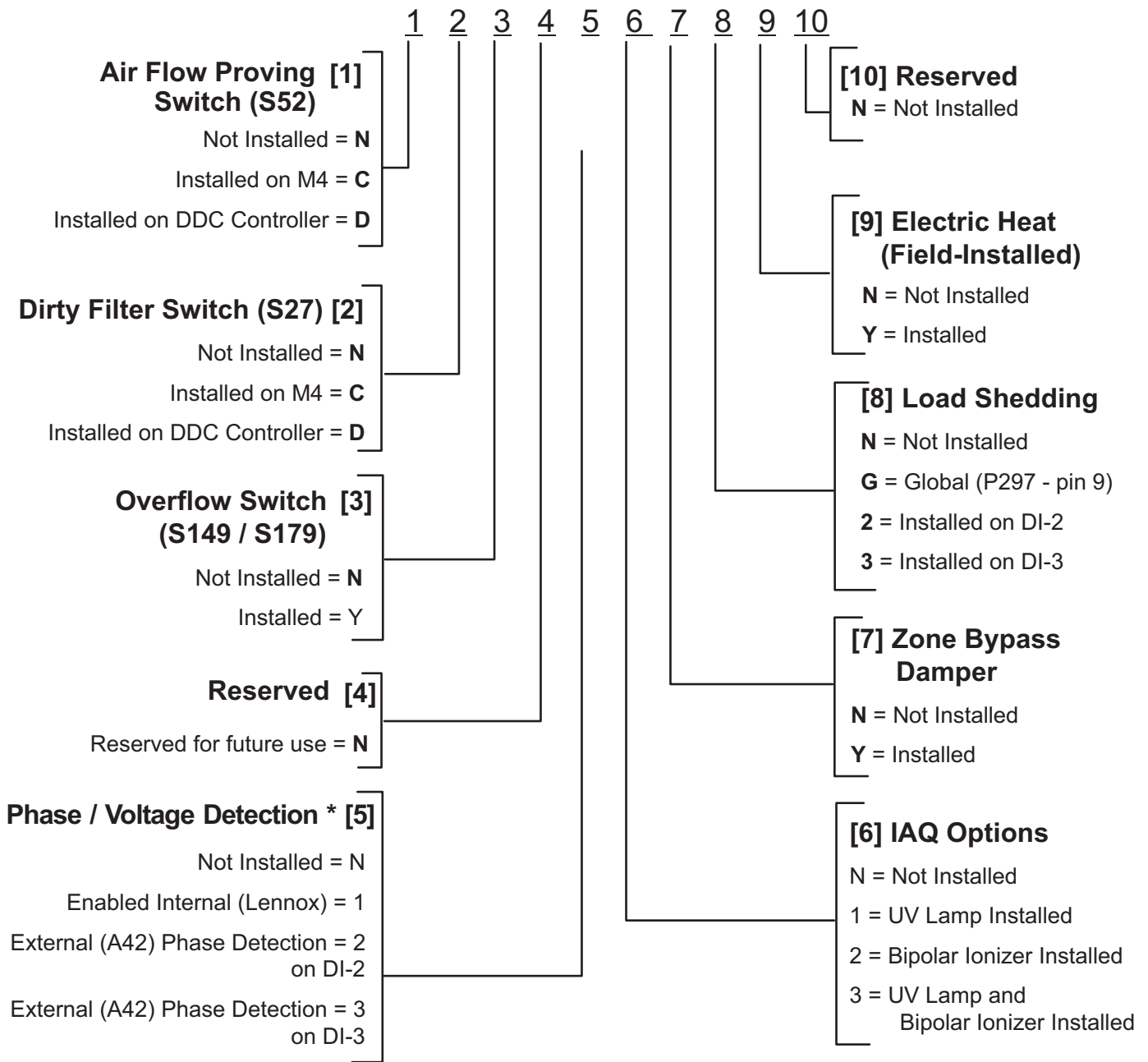

* When phase detection and voltage monitoring is enabled and wired incorrectly, the system will go into demand hold status and restart after six minutes.

FIGURE 32

Decommissioning

Before carrying out this procedure, it is essential that the technician is completely familiar with the equipment and all its detail. It is recommended good practice that all refrigerants are recovered safely.

Prior to the task being carried out, an oil and refrigerant sample shall be taken in case analysis is required prior to re-use of recovered refrigerant. It is essential that electrical power is available before starting decommissioning.

- a) Become familiar with the equipment and its operation.
- b) Isolate system electrically.
- c) Before attempting the procedure, ensure that:
 - mechanical handling equipment is available, if required, for handling refrigerant cylinders;
 - all personal protective equipment is available and being used correctly;
 - the recovery process is supervised at all times by a competent person;
 - recovery equipment and cylinders conform to the appropriate standards.
- d) Pump down refrigerant system, if possible.
- e) If a vacuum is not possible, make a manifold so that refrigerant can be removed from various parts of the system.

f) Make sure that cylinder is situated on the scales before recovery takes place.

g) Start the recovery machine and operate in accordance with instructions.

h) Do not overfill cylinders (no more than 80% volume liquid charge).

i) Do not exceed the maximum working pressure of the cylinder, even temporarily.

j) When the cylinders have been filled correctly and the process completed, make sure that the cylinders and the equipment are removed from site promptly and all isolation valves on the equipment are closed off.

k) Recovered refrigerant shall not be charged into another REFRIGERATING SYSTEM unless it has been cleaned and checked.



IMPORTANT

Equipment shall be labelled stating that it has been decommissioned and emptied of refrigerant. The label shall be signed and dated. Ensure that there are labels on the equipment that state the flammability of the refrigerant used.

START-UP REPORT

Job Name: _____
 Store No. _____ Start-Up Date: _____
 Address: _____
 City: _____ State: _____
 Start-Up Contractor: _____
 Technician: _____
 Model No.: _____
 Serial No.: _____
 RTU No.: _____ Catalog No.: _____

Inspections and Checks			
Damage?	Yes	No	R454B <input type="checkbox"/>
If yes, reported to: _____			
Verify factory and field-installed accessories.			
Check electrical connections. Tighten if necessary.			
Supply voltage: L1-L2 _____ L1-L3 _____ L2-L3 _____			
If unit contains a 208-230/240 volt transformer:			
Check primary transformer tap <input type="checkbox"/>			
Transformer secondary voltage: _____			

Cooling Checks												
Compressor Rotation <input type="checkbox"/> Ambient Temp. _____ Return Air Temp. _____ Supply Air Temp. _____												
	Compressor Amps			Compressor Volts			Pressures		Condenser Fan Amps			CC Heater Amps
	L1	L2	L3	L1-L2	L1-L3	L2-L3	Disch.	Suct.	L1	L2	L3	L1
1												
2												
3												
4												

Blower Checks			
Pulley/Belt Alignment <input type="checkbox"/>	Blower Rotation <input type="checkbox"/>		
Set Screws Tight <input type="checkbox"/>	Belt Tension <input type="checkbox"/>		
Nameplate Amps: _____		Volts: _____	
Motor	Amps	Volts	
	L1 _____	L1-L2 _____	
	L2 _____	L1-L3 _____	
	L3 _____	L2-L3 _____	

Heating Checks - Electric							
Return Air Temp.: _____ Supply Air Temp.: _____							
Limits Operate: <input type="checkbox"/>							
	Amps						
	L1	L2	L3		L1	L2	L3
1				10			
2				11			
3				12			
4				13			
5				14			
6				15			
7				16			
8				17			
9				18			

Heating Checks - Gas		
Fuel type: Nat. <input type="checkbox"/> LP <input type="checkbox"/> Inlet Pressure: _____ in. w.c.		
Return Air Temp.: _____ Supply Air Temp.: _____		
Altitude: _____ Primary Limits Operate: <input type="checkbox"/>		
CO ₂ %: _____		
Gas Valve	Manifold Pressure	
	Low Fire	High Fire
GV1		
GV2		

Accessory Checks	
Power Exhaust Amps	
1 _____	2 _____ None <input type="checkbox"/>
Economizer Operation	
Min. Pos. <input type="checkbox"/>	Motor travel full open/close <input type="checkbox"/>

Control Type