

INSTALLATION INSTRUCTIONS

⚠ WARNING

Improper installation, adjustment, alteration, service or maintenance can cause property damage, personal injury or loss of life. Installation and service must be performed by a licensed professional HVAC installer or equivalent, service agency, or the gas supplier.

Table of Contents

Unit Dimensions	4
Parts Arrangement	7
Shipping and Packing List	8
General	8
Requirements	8
Unit Support	10
Duct Connection	11
Rigging for Lifting	11
Condensate Drains	11
Connect Gas Piping	12
Pressure Test Gas Piping	13
High Altitude Derate	13
Electrical Connections - Power Supply	13
Electrical Connections - Control Wiring	14
Mobile Service App	16
Multi-Stage Air Volume Start-Up	19

LGX/LCX180S (15 Ton)

LGX/LCX210S (17.5 Ton)

LGX/LCX240S (20 Ton)

LGX/LCX300S (25 Ton)

ROOFTOP PACKAGED UNITS

508515-01

7/2024

R-454B

Blower Operation and Adjustments	21
Refrigerant Leak Detection System	27
Cooling Start-Up	27
Prognostic Sensors	41
RDS Sensors	44
Gas Heat Start-Up (Gas Units)	45
Heating Operation and Adjustments	46
Electric Heat Start-Up (LCX Units)	47
Preventative Maintenance / Repair	50
Adjusting Factory Unit Controller Settings	55
Decommissioning	58

RETAIN THESE INSTRUCTIONS FOR FUTURE REFERENCE

Attention!

Use this QR code to download the mobile service app. Follow the prompts to pair the app with the Unit Controller. Refer to the "Mobile Service App" section in this manual. The QR code is also available in the unit control area.



The app can be downloaded from the appropriate iOS or Android store. Look for the following icon.



⚠ CAUTION

As with any mechanical equipment, contact with sharp sheet metal edges can result in personal injury. Take care while handling this equipment and wear gloves and protective clothing.

⚠ WARNING

Only manufacturer approved auxiliary devices are permitted to be installed in this unit.

⚠ WARNING

If this appliance is conditioning a space with an area smaller than T_{Amin} or stored in a space with an area smaller than A_{min} as defined by this instruction, then that space must be without continuously operating open flames (e.g. an operating gas appliance) or other potential ignition sources (e.g. an operating electric heater or similar hot surface). A flame-producing device may be installed in the same space if the device is provided with an effective flame arrest system.

⚠ WARNING

- Do not use means to accelerate the defrosting process or to clean, other than those recommended by the manufacturer.
- The appliance shall be stored in a room without continuously operating ignition sources (for example: open flames, an operating gas appliance, or an operating electric heater).
- Do not pierce or burn.
- Be aware that refrigerants may not contain an odor.

⚠ CAUTION

Auxiliary devices which may be a potential ignition source shall not be installed in the duct work. Examples of such potential ignition sources are hot surfaces with a temperature exceeding 700°C and electric switching devices.

⚠ CAUTION

Any personnel installing, decommissioning, or performing maintenance on the unit must be properly trained with A2L refrigerants.

⚠ CAUTION

Leak Detection System installed. Unit must be powered except for service.

⚠ CAUTION

Servicing shall be performed only as recommended by the manufacturer.

⚠ WARNING

•This appliance must be installed in accordance with local and national wiring regulations.

•If the appliance is not fitted with an option for full disconnection from power, a means of disconnection must be incorporated in the fixed wiring in accordance with national and local wiring regulations.

⚠ WARNING

Ducts connected to an appliance shall not contain a potential ignition source.

⚠ CAUTION

The appliance is not to be used by persons (including children) with reduced physical, sensory or mental capabilities, or lack of experience and knowledge, unless they have been given supervision or instruction

⚠ CAUTION

Children should be supervised not to play with the appliance.

⚠ IMPORTANT

Pipe work, including piping material, pipe routing, and installation shall include protection from physical damage in operation and service, and be in compliance with national and local codes and standards, such as ASHRAE 15, ASHRAE 15.2, IAPMO Uniform Mechanical Code, ICC International Mechanical Code, or CSA B52. All field joints shall be accessible for inspection prior to being covered or enclosed.

⚠ IMPORTANT

Refrigerant sensors for refrigerant detection systems shall only be replaced with sensors specified by the appliance manufacturer.

⚠ CAUTION

This unit is equipped with electrically powered safety measures. To be effective, the unit must be electrically powered at all times after installation, other than when servicing.

A2L Refrigerant Considerations

Ensure that the work area is adequately ventilated before breaking into the system or conducting any hot work. A degree of ventilation shall continue during the period that the work is carried out. The ventilation should safely disperse any released refrigerant and preferably expel it externally into the atmosphere.

Check that cabling will not be subject to wear, corrosion, excessive pressure, vibration, sharp edges or any other adverse environmental effects, taking into account the effects of aging or continual vibration from sources such as compressors or fans.

Under no circumstances shall potential sources of ignition be used when searching for or detecting refrigerant leaks. A halide torch (or any other detector using a naked flame) shall not be used. Electronic leak detectors may be used to detect refrigerant leaks but, in the case of flammable refrigerants, the sensitivity may not be adequate, or may need re-calibration. (Detection equipment shall be calibrated in a refrigerant-free area.) Ensure that the detector is not a potential source of ignition and is suitable for the refrigerant used. Leak detection equipment shall be set at a percentage of the LFL of the refrigerant and shall be calibrated to the refrigerant employed, and the appropriate percentage of gas (25% maximum) is confirmed. Leak detection fluids are also suitable for use with most refrigerants but the use of detergents containing chlorine shall be avoided as the chlorine may react with the refrigerant and corrode the copper pipe-work. If a leak is suspected, all naked flames shall be removed/ extinguished. If a leakage of refrigerant is found which requires brazing, all of the refrigerant shall be recovered from the system, or isolated (by means of shut off valves) in a part of the system remote from the leak.

When breaking into the refrigerant circuit to make repairs – or for any other purpose – conventional procedures shall be used. However, for flammable refrigerants it is important that best practices be followed since flammability is a consideration. The following procedure shall be adhered to:

- Safely remove refrigerant following local and national regulations.
- Evacuate the circuit.
- Purge the circuit with inert gas.
- Evacuate.
- Purge the circuit with inert gas.
- Open the circuit

The refrigerant charge shall be recovered into the correct recovery cylinders if venting is not allowed by local and national codes. For appliances containing flammable refrigerants, the system shall be purged with oxygen-free nitrogen to render the appliance safe for flammable refrigerants. This process might need to be repeated several times. Compressed air or oxygen shall not be used for purging refrigerant systems. Refrigerants purging shall be achieved by breaking the vacuum in the system with oxygen-free nitrogen and continuing to fill until the working pressure is achieved, then venting to atmosphere, and finally pulling down to a vacuum. This process shall be vented down to atmospheric pressure to enable work to take place. Ensure that the outlet for the vacuum pump is not close to any potential ignition sources and that ventilation is available.

⚠ WARNING

To prevent serious injury or death:

- 1- Lock-out, tag-out before performing maintenance.
- 2- If system power is required (e.g., smoke detector maintenance), disable power to blower, remove fan belt where applicable, and ensure all controllers and thermostats are set to the OFF position before performing maintenance.
- 3- Always keep hands, hair, clothing, jewelry, tools, etc., away from moving parts.

LGX/LCX180S, 210S Unit Dimensions - Inches (mm) - Gas Heat Section Shown

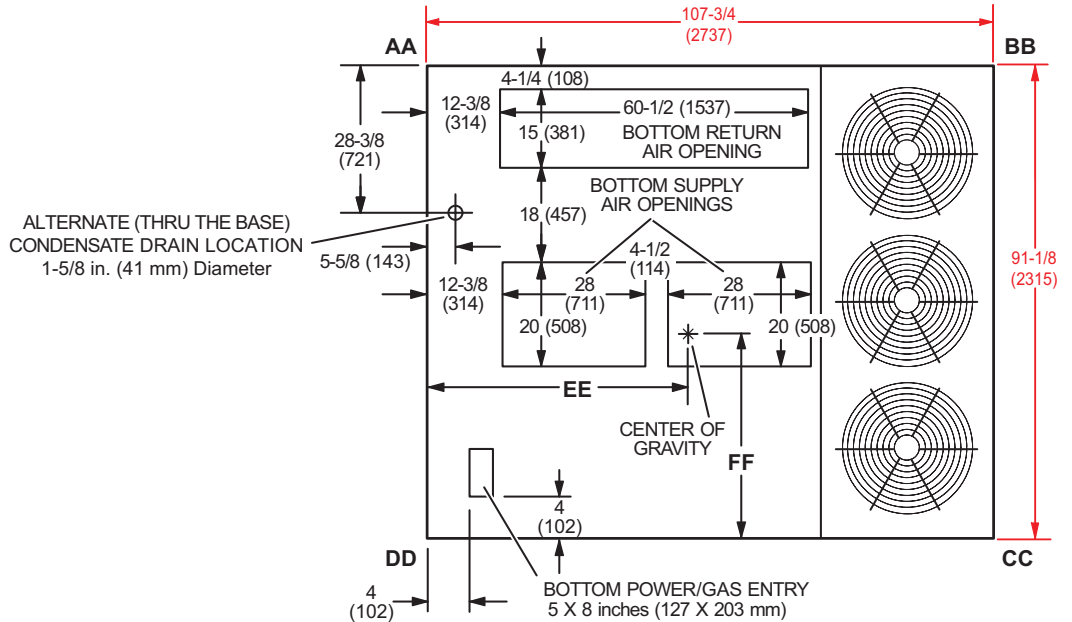

TOP VIEW

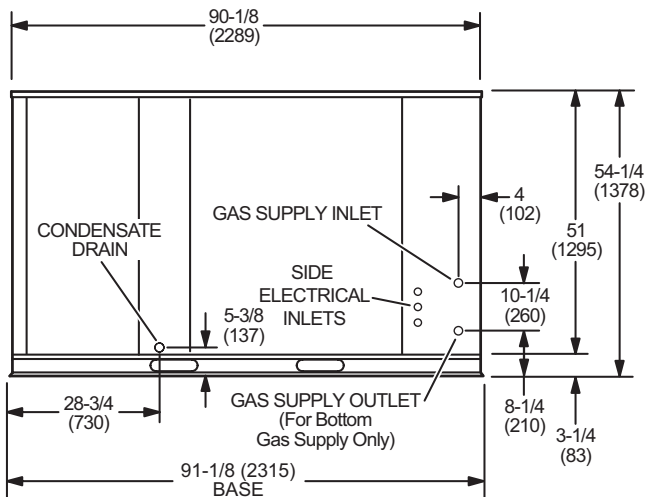

END VIEW

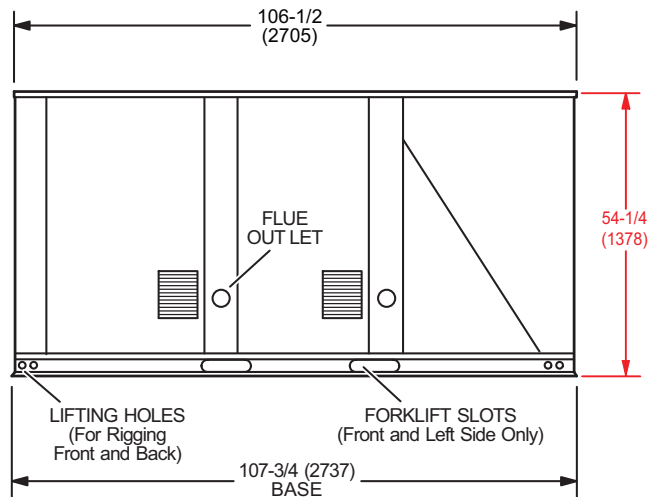

SIDE VIEW

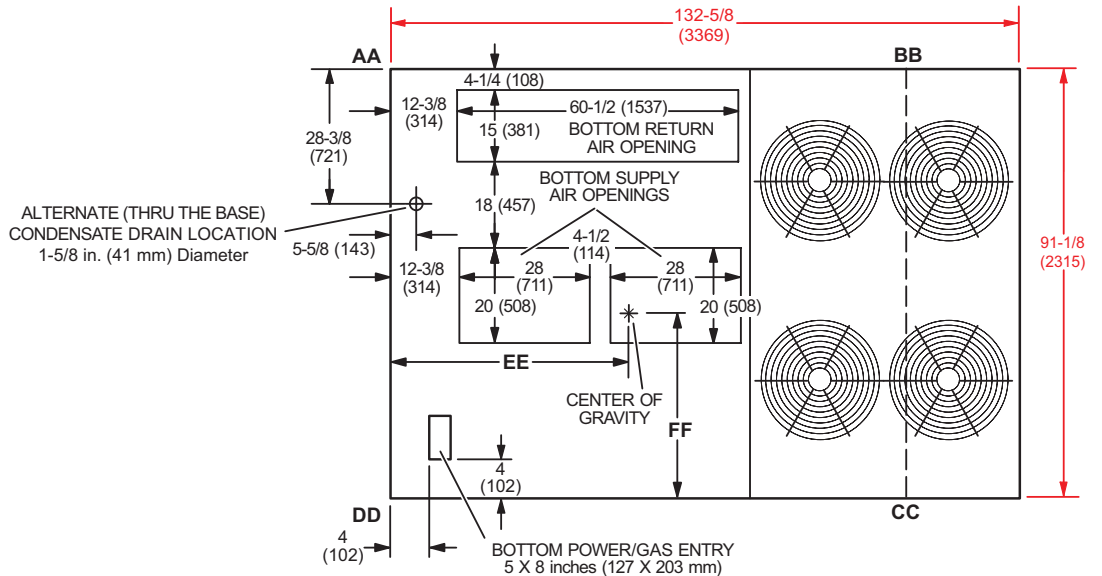

TOP VIEW

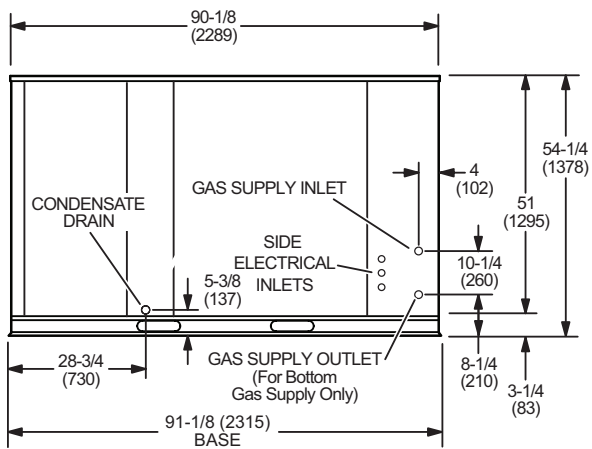

END VIEW

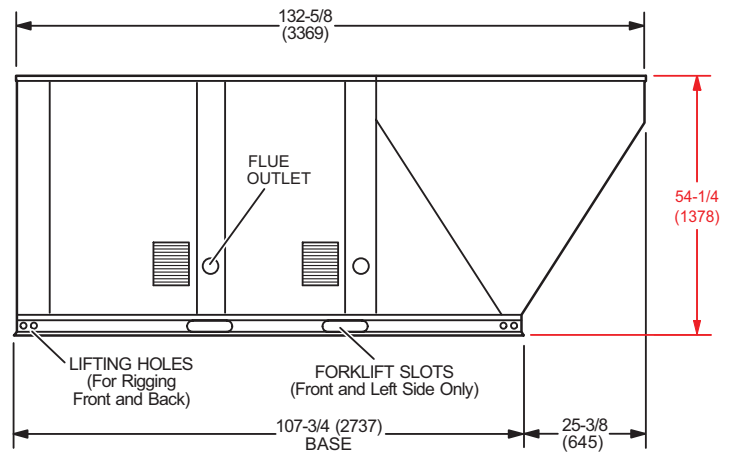

SIDE VIEW

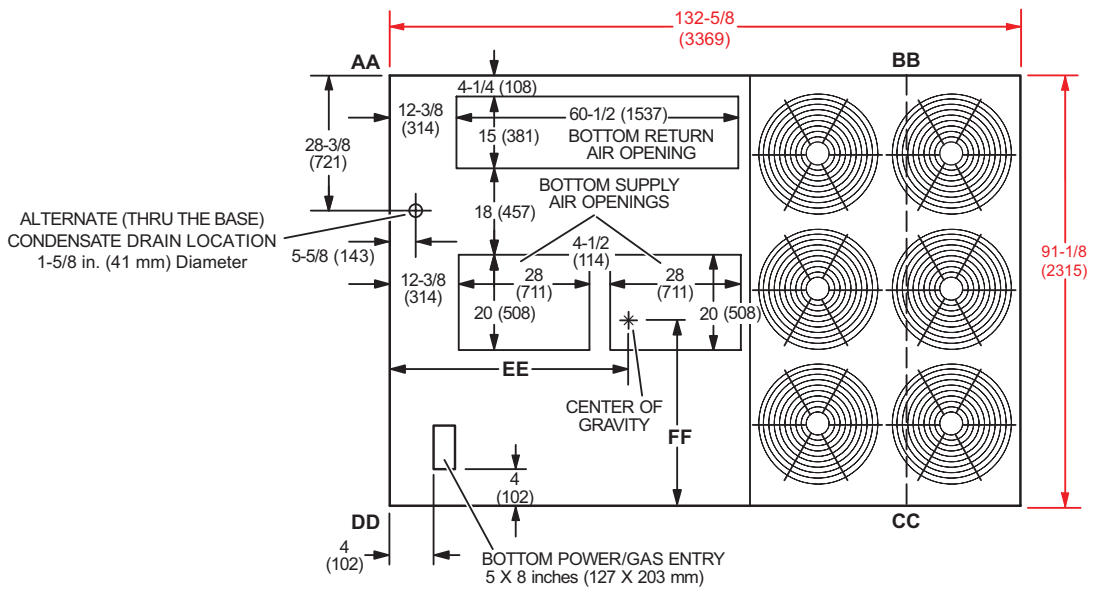

TOP VIEW

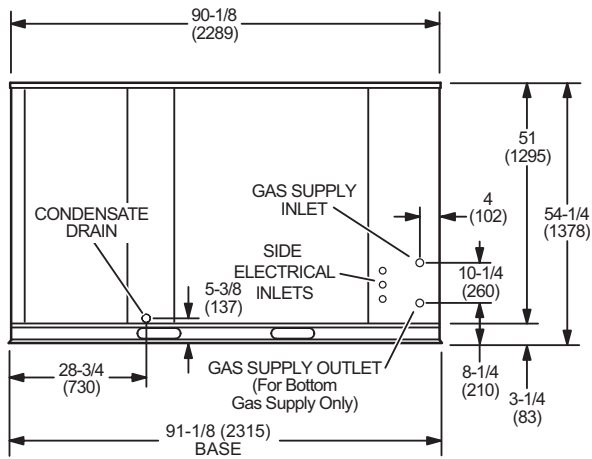

END VIEW

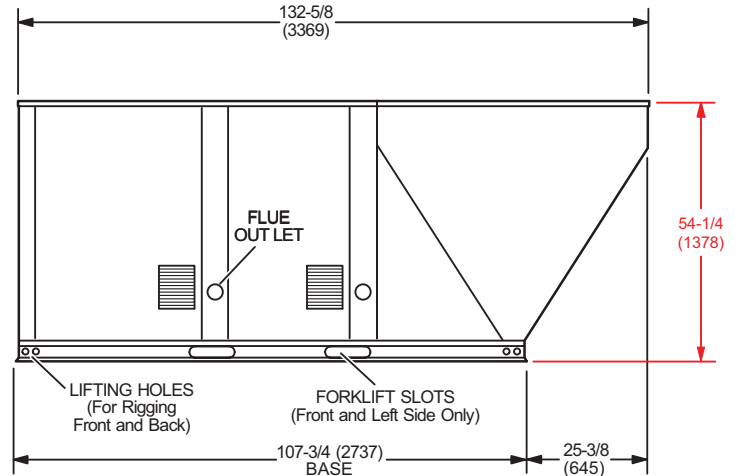

SIDE VIEW

LGX 180, 210, 240, 300 PARTS ARRANGEMENT

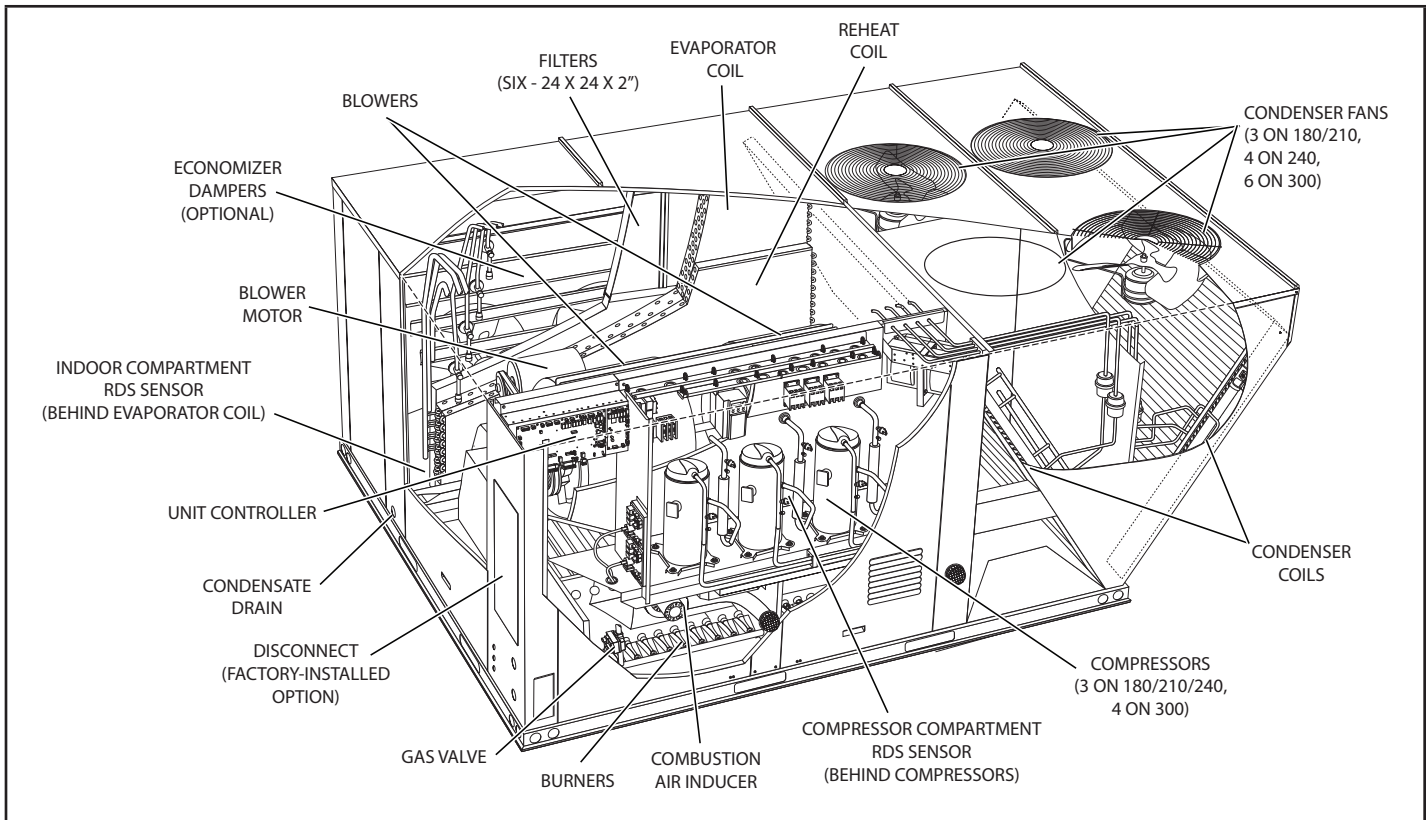

LCX 180, 210, 240, 300 PARTS ARRANGEMENT

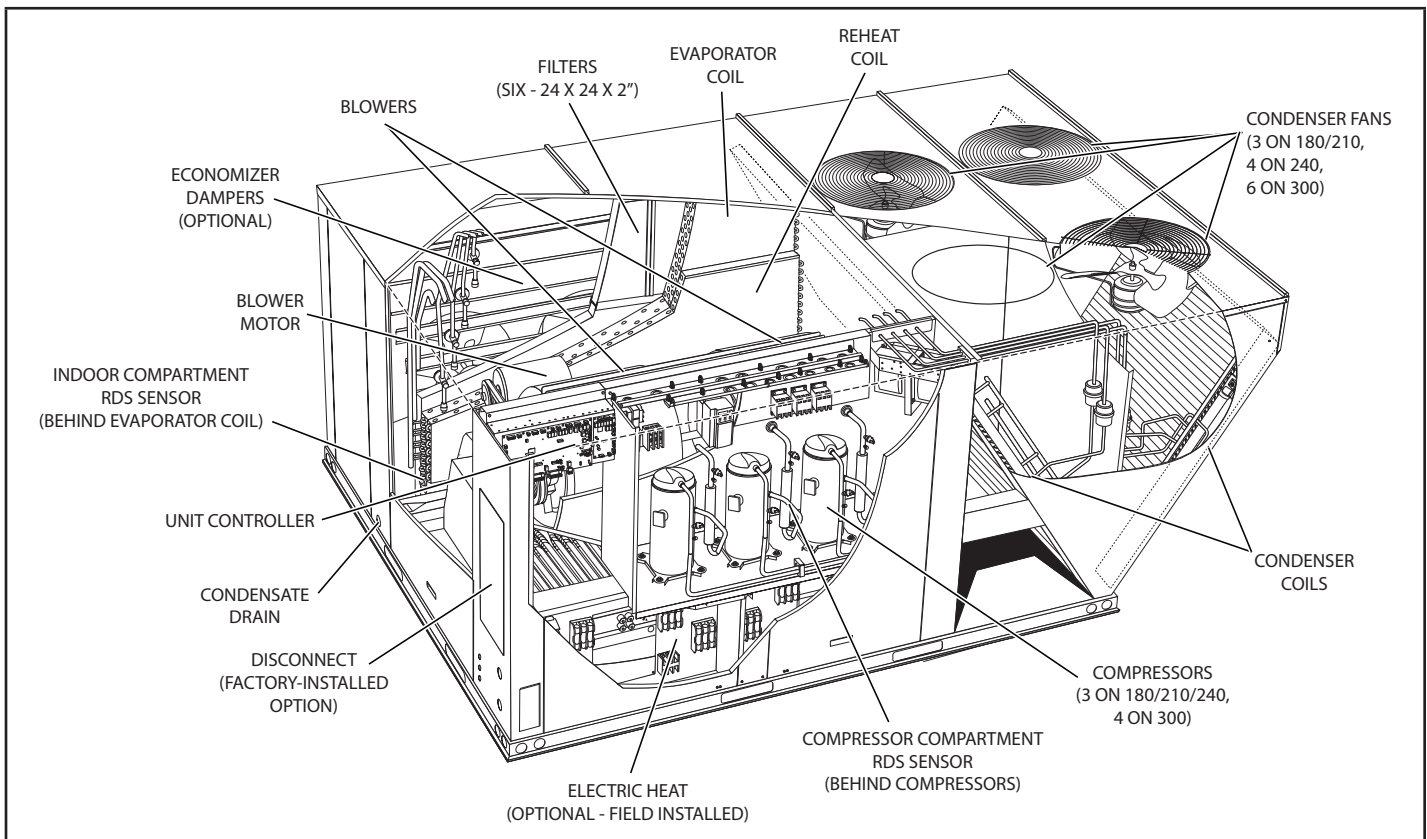

Shipping and Packing List

Package 1 of 1 contains:

1 - Assembled unit

Check unit for shipping damage. Receiving party should contact last carrier immediately if shipping damage is found.

General

These instructions are intended as a general guide and do not supersede local codes in any way. Authorities having jurisdiction should be consulted before installation.

The LGX180, 210, 240, & 300 gas/electric packaged rooftop units are available in 260,000, 360,000, or 480,000 Btuh heating inputs.

The LCX cooling packaged rooftop unit is the same basic design as the LGX unit except for the heating section. Optional electric heat is field-installed in LCX units.

LGX and LCX units have identical refrigerant circuits with respective 15, 17-1/2, 20 and 25 ton cooling capacities. 180, 210, and 240 units contain 3 compressors; all are fixed speed. 300 units contain four compressors; all are fixed speed compressors.

Units come standard with a factory-installed, all-aluminum condenser coil.

Units use R454B, an ozone-friendly HFC refrigerant. Refer to the Cooling Start-Up section for precautions when installing unit.

⚠ WARNING



Electric shock hazard and danger of explosion. Can cause injury, death or product or property damage. Turn off gas and electrical power to unit before performing any maintenance or servicing operations on the unit. Follow lighting instructions attached to unit when putting unit back into operation and after service or maintenance.

Requirements

See FIGURE 1 for unit clearances.

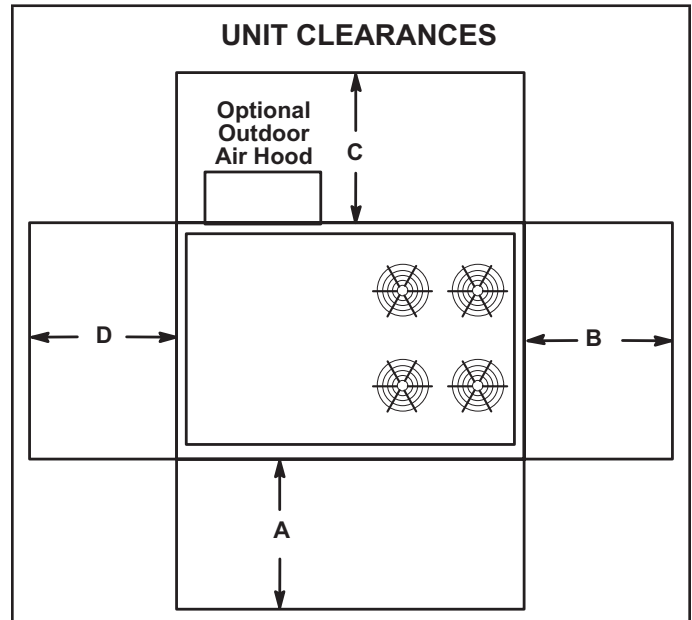

FIGURE 1

Unit Clearance	A in.(mm)	B in.(mm)	C in.(mm)	D in.(mm)	Top Clearance
Service Clearance	60 (1524)	36 (914)	36 (914)	66 (1676)	Unobstructed
Clearance to Combustibles	36 (914)	1 (25)	1 (25)	1 (25)	Unobstructed
Minimum Operation Clearance	36 (914)	36 (914)	36 (914)	41 (1041)	Unobstructed

NOTE - Entire perimeter of unit base requires support when elevated above mounting surface.

Service Clearance - Required for removal of serviceable parts

Clearance to Combustibles - Required clearance to combustible material (gas units). On LCX units, see clearance to combustible materials on heater rating plate.

Minimum Operation Clearance - Required clearance for proper unit operation.

Minimum R454B Space and CFM Requirements

Minimum Airflow ¹		
Unit	Q _{min} (CFM)	Q _{min} (m ³ h)
LGX/LCX180	177	301
LGX/LCX210	206	350
LGX/LCX240	193	328
LGX/LCX300	156	265

¹ **NOTE** - The minimum airflow is the lowest CFM allowed during venting operation (leak mitigation).

Refrigerant Charge R-454B		
Unit	M _c (lbs)	M _c (kg)
LGX/LCX180	6.7	3.04
LGX/LCX210	7.8	3.54
LGX/LCX240	7.3	3.31
LGX/LCX300	5.9	2.68

Minimum Room Area of Conditioned Space ²		
Unit	TA _{min} (ft ²)	TA _{min} (m ²)
LGX/LCX180	98.2	9.12
LGX/LCX210	114.3	10.62
LGX/LCX240	106.9	9.93
LGX/LCX300	86.4	8.03

² **NOTE** - The minimum room area of conditioned space is the smallest area the unit can service.

Altitude Adjustment Factor ³									
Halt	0	200	400	600	800	1000	1200	1400	1600
AF	1	1	1	1	1.02	1.05	1.04	1.1	1.12
Halt	1600	1800	2000	2200	2400	2600	2800	3000	3200
AF	1.12	1.15	1.18	1.21	1.25	1.28	1.32	1.36	1.4

³ **NOTE** - Use the Altitude Adjustment Factor to adjust the values in the tables above to different altitudes. Find the relevant altitude above sea level in the two "Halt" rows and then multiply the value needed from the tables above by the altitude factor number. Example: For the minimum airflow in CFM for an LGX/LCX180 at 1000 ft. above sea level, multiply 177 by 1.05 to get 185.85 CFM as the new Q_{min}.

NOTICE

Roof Damage!

This system contains both refrigerant and oil. Some rubber roofing material may absorb oil, causing the rubber to swell. Bubbles in the rubber roofing material can cause leaks. Protect the roof surface to avoid exposure to refrigerant and oil during service and installation. Failure to follow this notice could result in damage to roof surface.

Use of this unit as a construction heater or air conditioner is not recommended during any phase of construction. Very low return air temperatures, harmful vapors and operation of the unit with clogged or misplaced filters will damage the unit.

If this unit has been used for heating or cooling of buildings or structures under construction, the following conditions must be met or the warranty will be void:

- The vent hood must be installed per these installation instructions.
- A room thermostat must control the unit. The use of fixed jumpers that will provide continuous heating or cooling is not allowed.
- A pre-filter must be installed at the entry to the return air duct.
- The return air duct must be provided and sealed to the unit.
- Return air temperature range between 55°F (13°C) and 80°F (27°C) must be maintained.
- Air filters must be replaced and pre-filters must be removed upon construction completion.
- The input rate and temperature rise must be set per the unit rating plate.
- The heat exchanger, components, duct system, air filters and evaporator coil must be thoroughly cleaned following final construction clean-up.
- The unit operating conditions (including airflow, cooling operation, ignition, input rate, temperature rise and venting) must be verified according to these installation instructions.

This appliance is not intended for use by persons (including children) with reduced physical, sensory, or mental capabilities, or lack of experience and knowledge, unless they have been given supervision or instruction concerning use of the appliance by a person responsible for their safety.

IMPORTANT

The Clean Air Act of 1990 bans the intentional venting of refrigerant (CFC's and HCFC's) as of July 1, 1992. Approved methods of recovery, recycling or reclaiming must be followed. Fines and/or incarceration may be levied for non-compliance.

Unit Support

In downflow discharge installations, install the unit on a non-combustible surface only. Unit may be installed on combustible surfaces when used in horizontal discharge applications or in downflow discharge applications when installed on an C1CURB14C roof mounting frame.

NOTE - Securely fasten roof frame to roof per local codes.

CAUTION

To reduce the likelihood of supply / return air bypass and promote a proper seal with the RTU, duct work / duct drops / diffuser assemblies must be supported independently to the building structure.

A-Downflow Discharge Application

Roof Mounting with C1CURB

- 1 - The C1CURB roof mounting frame must be installed, flashed and sealed in accordance with the instructions provided with the frame.
- 2 - The C1CURB roof mounting frame should be square and level to 1/16" per linear foot (5mm per linear meter) in any direction.
- 3 - Duct must be attached to the roof mounting frame and not to the unit; supply and return plenums must be installed before setting the unit.

Installer's Roof Mounting Frame

Many types of roof frames can be used to install the unit depending upon different roof structures. Items to keep in mind when using the building frame or supports are:

- 1 - The base is fully enclosed and insulated, so an enclosed frame is not required.
- 2 - The frames or supports must be constructed with non-combustible materials and should be square and level to 1/16" per linear foot (5mm per linear meter) in any direction.
- 3 - Frame or supports must be high enough to prevent any form of moisture from entering unit. Recommended minimum frame height is 14" (356mm).
- 4 - Duct must be attached to the roof mounting frame and not to the unit. Supply and return plenums must be installed before setting the unit.

- Units require support along all four sides of unit base. Supports must be constructed of steel or suitably treated wood materials.

NOTE - When installing a unit on a combustible surface for downflow discharge applications, an C1CURB14C roof mounting frame is required.

B-Horizontal Discharge Applications

- Units installed in horizontal airflow applications must use an C1CURB14C horizontal roof mounting frame. The supply air duct connects to the horizontal supply air opening on the C1CURB14C. The return air duct connects to the unit horizontal return air opening. Refer to unit dimensions.
- Specified installation clearances must be maintained when installing units. Refer to FIGURE 1.
- Top of support slab should be approximately 4" (102mm) above the finished grade and located so no run-off water from higher ground can collect around the unit.
- Units require support along all four sides of unit base. Supports must be constructed of steel or suitably treated wood materials.

Duct Connection

All exterior ducts, joints and openings in roof or building walls must be insulated and weather-proofed with flashing and sealing compounds in accordance with applicable codes. Any duct passing through an unconditioned space must be insulated.

⚠ CAUTION

In downflow applications, do not drill or punch holes in base of unit. Leaking in roof may occur if unit base is punctured.

Rigging for Lifting

Rig unit for lifting by attaching four cables to holes in unit base rail. See FIGURE 2.

- Detach wooden base protection before rigging.
- Connect rigging to the unit base using both holes in each corner.
- All panels must be in place for rigging.
- Place field-provided H-style pick in place just above top edge of unit. Frame must be of adequate strength and length. (H-style pick prevents damage to unit.)

RIGGING

Unit	*Weight	
	Lbs.	Kg.
LGX/LCX180	2404	1090
LGX/LCX210	2574	1167
LGX/LCX240	2746	1246
LGX/LCX300	2950	1338

*Maximum weight with all available factory-installed accessories.

LIFTING POINT SHOULD BE DIRECTLY ABOVE CENTER OF GRAVITY

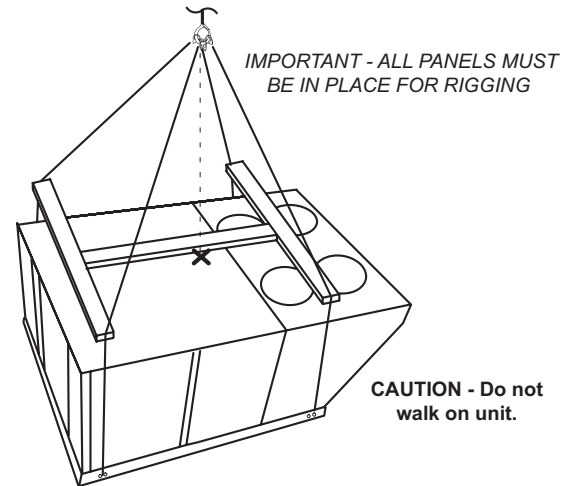

FIGURE 2

Condensate Drains

Remove cap and make drain connection to the 1" N.P.T. drain coupling provided on unit. A trap must be installed between drain connection and an open vent for proper condensate removal. See FIGURE 3. It is sometimes acceptable to drain condensate onto the roof or grade; however, a tee should be fitted to the trap to direct condensate downward. The condensate line must be vented. Check local codes concerning condensate disposal. Refer to page 4, page 5, page 6 and page 7 for condensate drain location.

NOTE - The drain pan is made with a glass reinforced engineered plastic capable of withstanding typical joint torque but can be damaged with excessive force. Tighten pipe nipple hand tight and turn an additional quarter turn.

CONDENSATE DRAIN CONNECTION

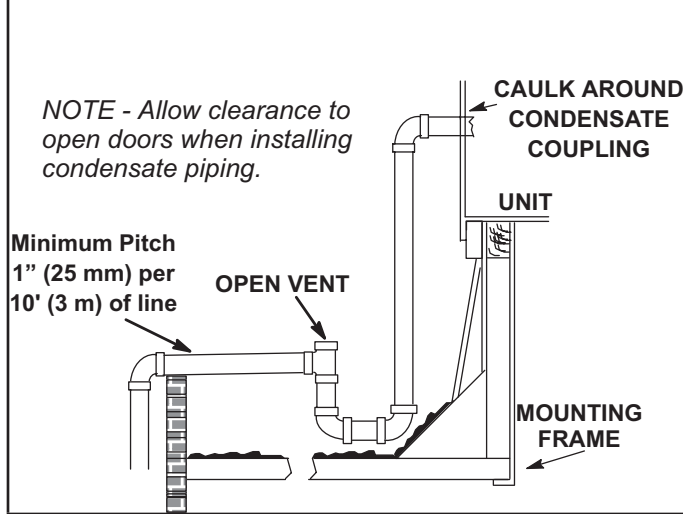

FIGURE 3

Connect Gas Piping

Before connecting piping, check with gas company or authorities having jurisdiction for local code requirements. When installing gas supply piping, length of run from gas meter must be considered in determining pipe size for 0.5" w.c. (.12kPa) maximum pressure drop. Do not use supply pipe smaller than unit gas connection. For natural gas units, operating pressure at the unit gas connection must be a minimum of 4.7" w.c. (1.17kPa) and a maximum of 10.5" (2.60kPa) w.c. For LP/propane gas units, operating pressure at the unit gas connection must be a minimum of 11" w.c. (2.74kPa) and a maximum of 13.5" w.c. (3.36kPa).

When making piping connections a drip leg should be installed on vertical pipe runs to serve as a trap for sediment or condensate. A 1/8" N.P.T. plugged tap is located on gas valve for test gauge connection. Refer to Heating Start-Up section for tap location. Install a ground joint union between the gas control manifold and the main manual shut-off valve. See FIGURE 4 for gas supply piping entering outside the unit. See FIGURE 5 for gas supply entering through bottom of unit.

Compounds used on threaded joints of gas piping shall be resistant to the action of liquefied petroleum gases.

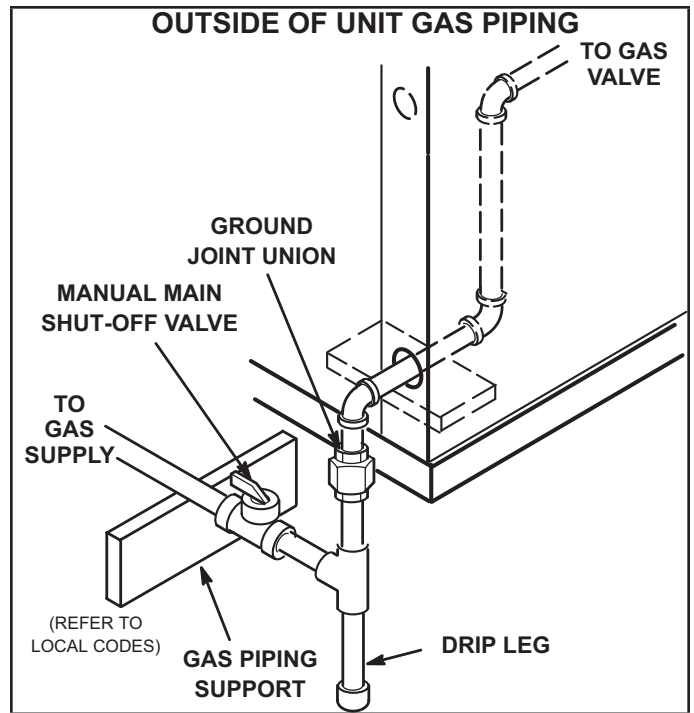

FIGURE 4

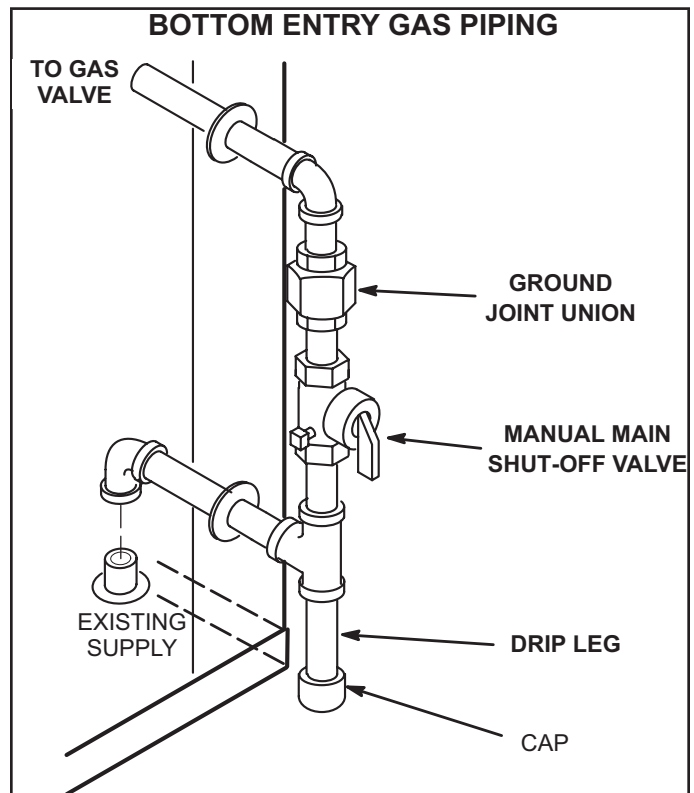

FIGURE 5

Pressure Test Gas Piping

When pressure testing gas lines, the gas valve must be disconnected and isolated. Gas valves can be damaged if subjected to more than 0.5 psig (3.48kPa). See FIGURE 6.

NOTE - Codes may require that manual main shut-off valve and union (furnished by installer) be installed in gas line external to unit. Union must be of the ground joint type.

After all connections have been made, check all piping connections for gas leaks. Also check existing unit gas connections up to the gas valve; loosening may occur during installation. Use a leak detection solution or other preferred means. Do not use matches, candles, or other sources of ignition to check for gas leaks.

NOTE - In case emergency shut down is required, turn off the main manual shut-off valve and disconnect main power to unit. These devices should be properly labeled by the installer.

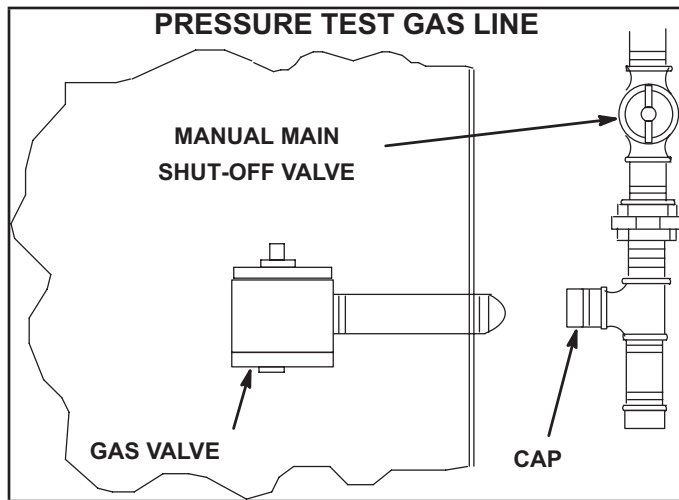

FIGURE 6

⚠ CAUTION

Some soaps used for leak detection are corrosive to certain metals. Carefully rinse piping thoroughly after leak test has been completed. Do not use matches, candles, flame or other sources of ignition to check for gas leaks.

⚠ WARNING



Danger of explosion. Can cause injury or product or property damage. Do not use matches, candles, flame or other sources of ignition to check for leaks.

High Altitude Derate

Locate the high altitude conversion sticker in the unit literature bag. Fill out the conversion sticker and affix next to the unit nameplate. High altitude kits are available for field-installation.

Refer to TABLE 1 for high altitude adjustments.

TABLE 1
HIGH ALTITUDE DERATE

Unit	Altitude Ft.*	Gas Manifold Pressure
2000-4500	2000-4500	See Unit Nameplate
169 KBtuh	4500 & Above	Derate 2% / 1000 Ft. Above Sea Level
260-380 KBtuh	4500 & Above	Derate 4% / 1000 Ft. Above Sea Level

*Units installed at 0-2000 feet do not need to be modified

NOTE - This is the only permissible derate for these units.

Electrical Connections - Power Supply

A-Wiring

Route field wiring in conduit between bottom power entry and disconnect. See FIGURE 7. This does not supersede local codes or authorities having jurisdiction.

Do not apply power or close disconnect switch until installation is complete. Refer to start-up directions. Refer closely to unit wiring diagram.

Refer to unit nameplate for minimum circuit ampacity and maximum fuse size.

- 1 - Units are factory-wired for 240/460/575 volt supply. For 208V supply, remove the insulated terminal cover from the 208V terminal on the control transformer. Move the wire from the transformer 240V terminal to the 208V terminal. Place the insulated terminal cover on the unused 240V terminal.
- 2 - Route power through the bottom power entry area and connect to line side of unit disconnect, circuit breaker or terminal block. See unit wiring diagram.
- 3 - Units With Optional 120v GFCI Outlet

Route and connect separate 120v wiring to GFCI outlets. Route field wiring in conduit between bottom power entry and GFCI. See FIGURE 7.

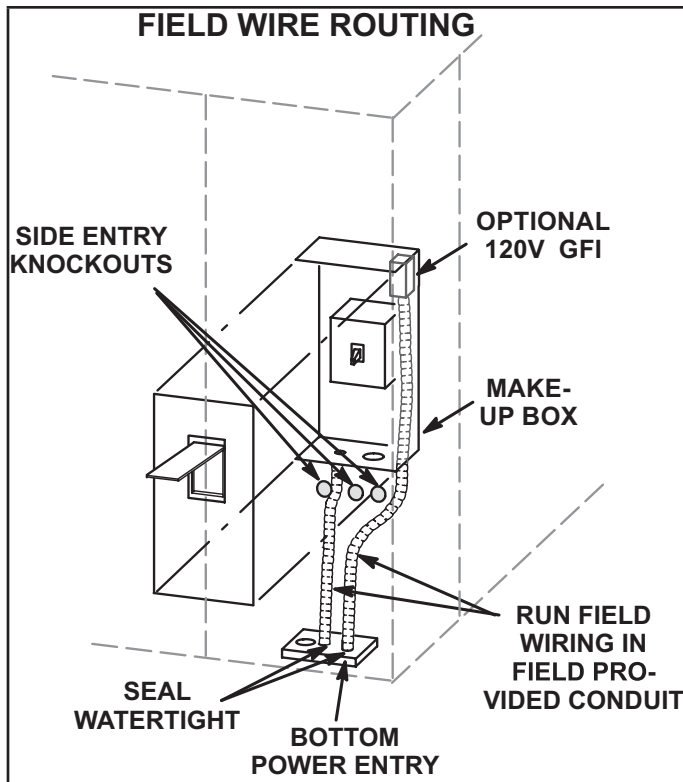

FIGURE 7

B-Unbalanced Three-Phase Voltage

Units equipped with an inverter (VFD) are designed to operate on balanced, three-phase power. Operating units on unbalanced three-phase power will reduce the reliability of all electrical components in the unit. Unbalanced power is a result of the power delivery system supplied by the local utility company.

Factory-installed inverters are sized to drive blower motors with an equivalent current rating using balanced three-phase power. When unbalanced three-phase power is supplied; the installer must replace the existing factory-installed inverter with an inverter that has a higher current rating to allow for the imbalance. Use TABLE 2 to determine the appropriate replacement inverter.

TABLE 2
INVERTER UP-SIZING

Factory-Installed Inverter HP	Replacement Inverter HP
2	5
3	7-1/2
5	10
7.5	15
10	20

Electrical Connections - Control Wiring

Connect either a thermostat, room/zone sensor, or direct digital controller; one of the three are required for unit function. Refer to the literature provided with each device and the following information.

NOTE - Optional wireless sensors are available for use with this unit.

A-Thermostat Location

Room thermostat mounts vertically on a standard 2" X 4" handy box or on any non-conductive flat surface.

Locate thermostat approximately 5 feet (1524mm) above the floor in an area with good air circulation at average temperature. Avoid locating the room thermostat where it might be affected by:

- drafts or dead spots behind doors and in corners
- hot or cold air from ducts
- radiant heat from sun or appliances
- concealed pipes and chimneys

B-Wire Routing

Route thermostat cable or wires from subbase through knockout provided in unit. Use 18 AWG wire for all applications using remotely installed electro-mechanical and electronic thermostats.

IMPORTANT - Unless field thermostat wires are rated for maximum unit voltage, they must be routed away from line voltage wiring.

C-Wire Connections

The Unit Controller will operate the unit from a thermostat or zone sensor based on the System Mode. The default System Mode is the thermostat mode. Refer to the Unit Controller Setup Guide to change the System Mode. Use the mobile service app menu and select:

SETTINGS > INSTALL

NOTE - Unit Controller is capable of up to four stages of cooling in network control mode.

1 - Default Thermostat Mode

The Unit Controller will operate two stages of heating and cooling based on thermostat demands. Install thermostat assembly in accordance with instructions provided with thermostat. See FIGURE 8 for field wiring and refer to wiring diagrams on unit.

IMPORTANT - Terminal connections at the wall plate or subbase must be made securely. Loose control wire connections may result in intermittent operation.

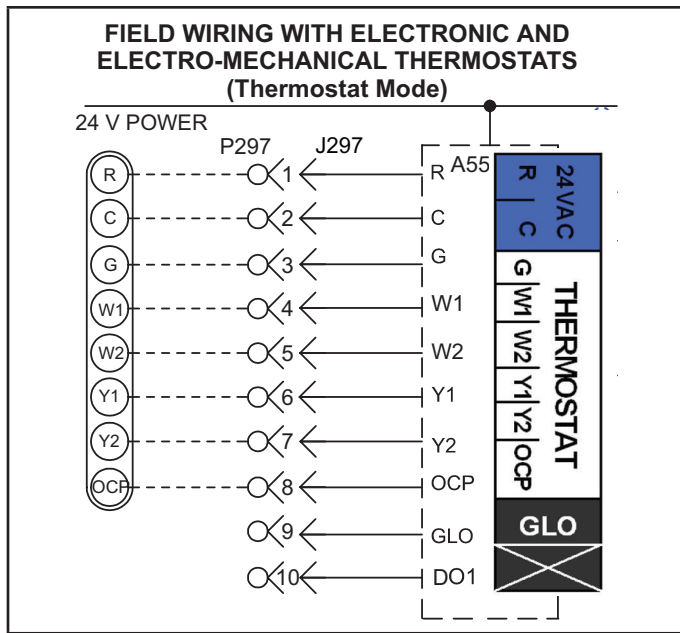

FIGURE 8

2 - Zone Sensor Mode

The Unit Controller will operate heating and cooling based on the Unit Controller internal setpoints and the temperature from the A2 zone sensor. An optional Network Control Panel (NCP) can also be used to provide setpoints. A thermostat or return air sensor can be used as a back-up mode. Make zone sensor wiring connections as shown in FIGURE 9.

NOTE - Install sensor and make communication wiring connections as shown in literature provided with sensor.

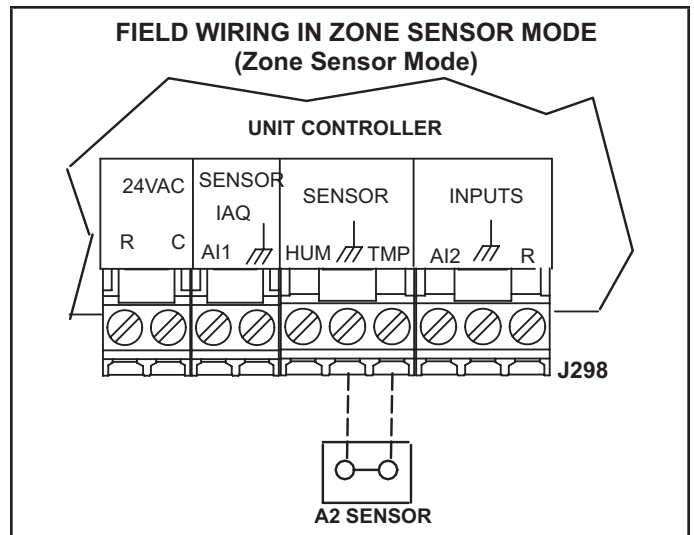

FIGURE 9

Mobile Service App

Setup and configure each rooftop unit using the mobile service app (Android or iOS devices supported).

A-Mobile Device Requirements

- Bluetooth connection.
- Android hardware requires 2GB RAM and a 2Ghz core processor. Tablets are supported.
- The app is available for both iOS 11.0 or higher (App Store) and Android 9.0 or higher (Google Play).

B-Download the App

Use your mobile device to scan the QR code from the cover page and download the mobile service app to your mobile device.

C-Pair the App to the Unit Controller

- 1 - Apply power to the unit and wait until the Unit Controller has booted-up (approximately two minutes).
- 2 - Press and hold the pair button for five seconds.
- 3 - The unit (or list of units) will appear; select the appropriate unit. When the app code matches the four-character code on the Unit Controller display, the unit is paired (within 10 seconds). Note the following:
 - The app will list the units by signal strength; the RTU name will be displayed.
 - Once paired, the RTU name, model number, serial number and firmware version will be displayed.

Please refer to the manufacturer’s website for additional technical information and self-help support.

D-App Menus

See FIGURE 10 for the menu overview. Follow the app prompts in the Install, Network Integration, and Test and Balance menus. Verify the app is setup properly for the unit application (including the date and time). Refer to FIGURE 11, FIGURE 12, and FIGURE 13.

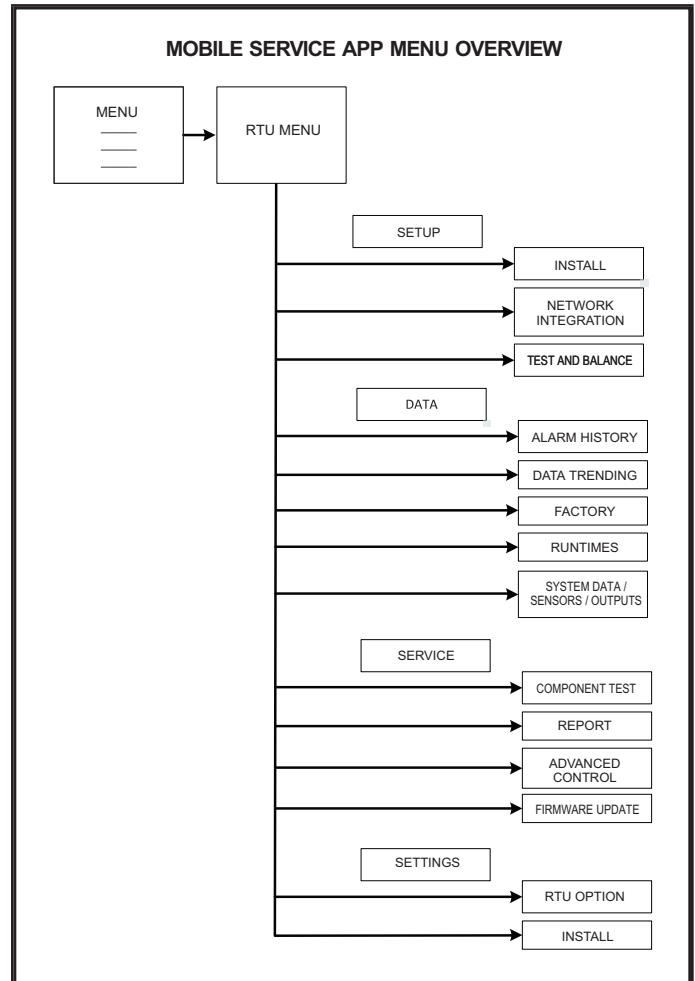

FIGURE 10

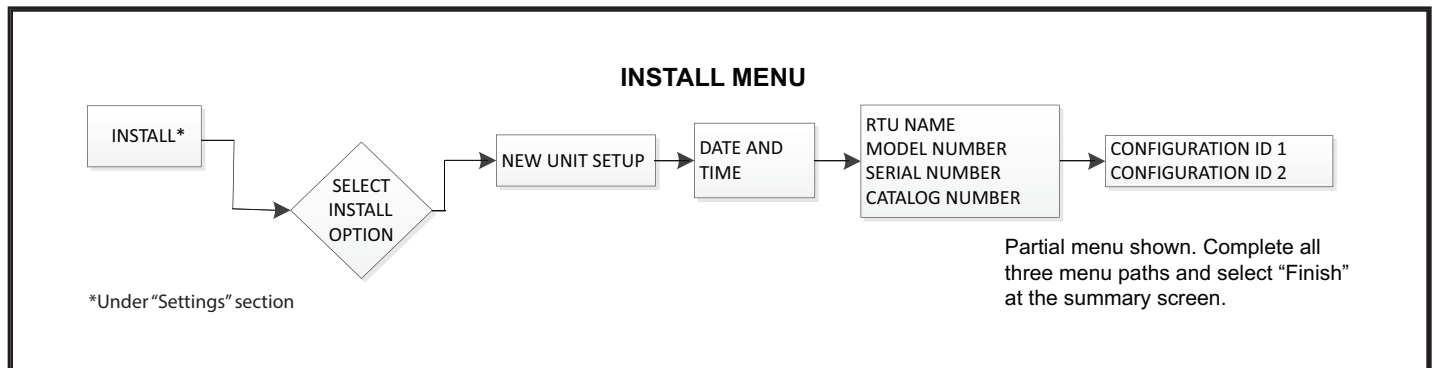

FIGURE 11

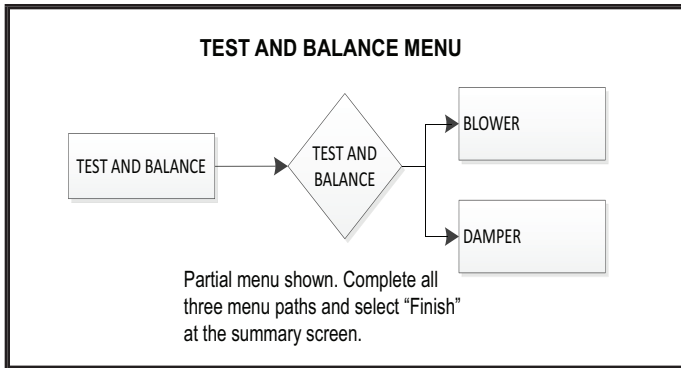

FIGURE 12

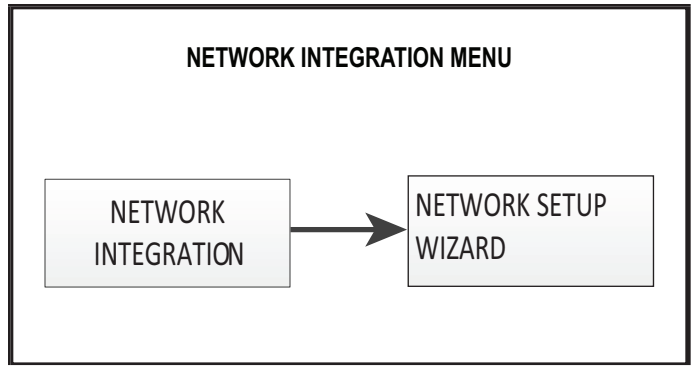

FIGURE 13

E-Unit Controller Components

See FIGURE 14 for Unit Controller components. See FIGURE 15 and TABLE 3 for pushbutton and LED functions.

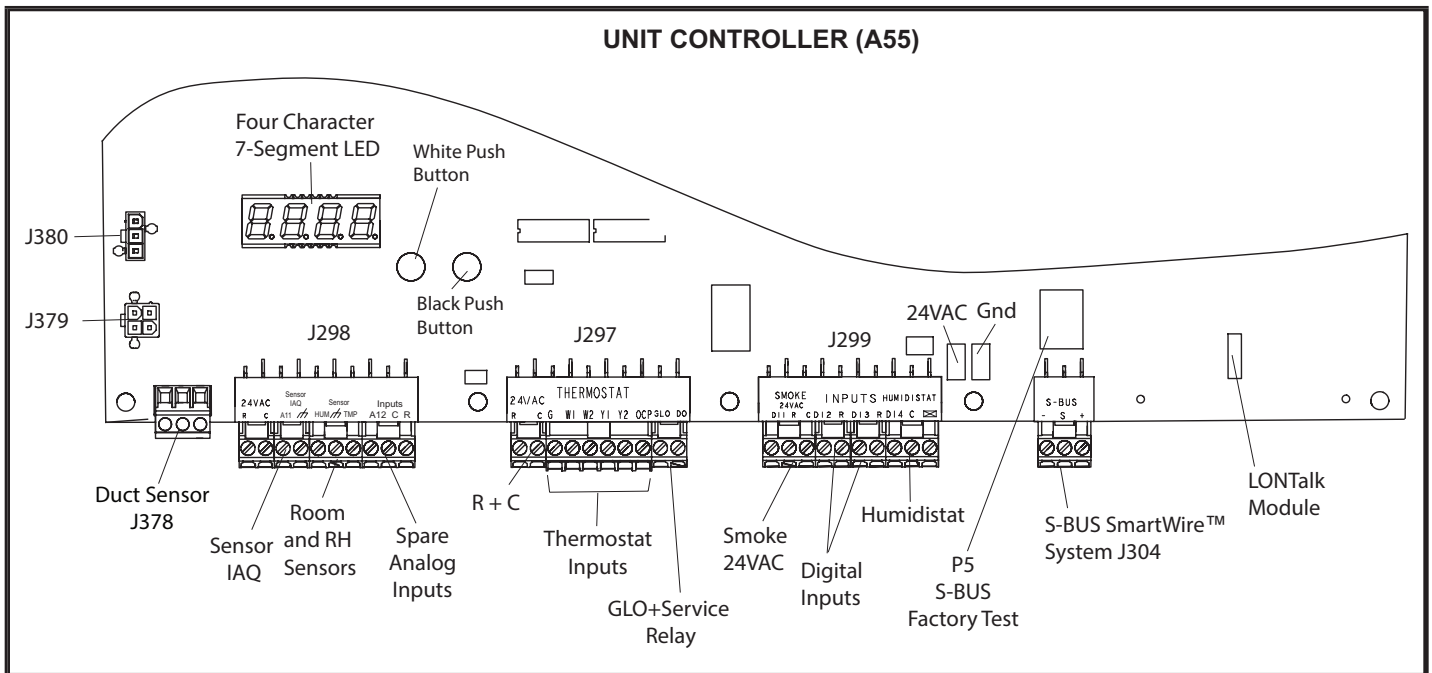

FIGURE 14

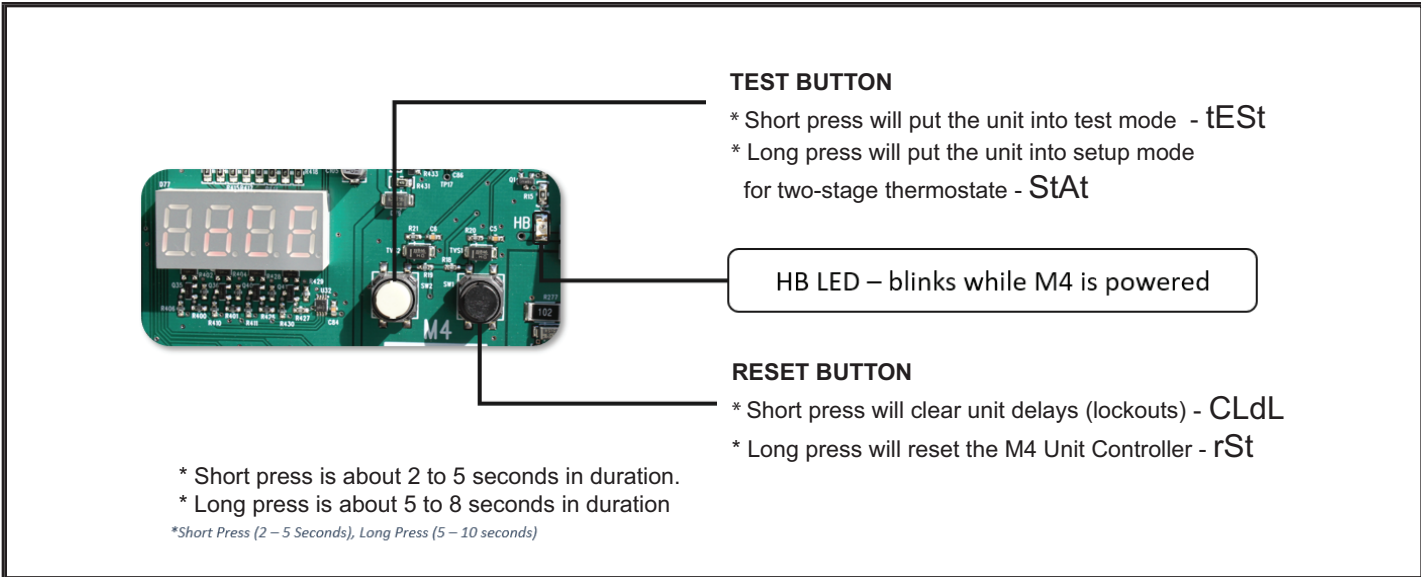

FIGURE 15

TABLE 3
UNIT CONTROLLER PUSHBUTTON CODES

Code	Cause	Action
CLdL	Black Button: Short Press	Clear Delays
rSt	Black Button: Long Press	Reset
tEst	White Button: Short Press	TSTAT Test
StAt	White Button: Long Press (In Pre-Install state)	TSTAT Override
tEst	White Button: Long Press (NOT in Pre-Install State)	TSTAT Test
Short Press : 2 to 5 seconds. Long Press : 5 to 8 seconds.		

Multi-Stage Air Volume Start-Up

The blower rotation will always be correct on units equipped with an inverter. Checking blower rotation is not a valid method of determining voltage phasing for incoming power.

Units Equipped With Optional Voltage or Phase Detection - The Unit Controller checks the incoming power during start-up. If the voltage or phase is incorrect, the Unit Controller will display an alarm and the unit will not start.

A-Design Specifications

Use TABLE 4 to fill in field-provided, design specified blower CFM for appropriate unit.

B-Set Maximum CFM

Use TABLE 4 to determine highest blower CFM for appropriate unit. Adjust the blower pulley to deliver that amount of CFM with only the blower operating. See Determining Unit CFM in the Blower Operation and Adjustment section.

C-Set Blower Speeds

- 1 - Use the following mobile service app menu to enter the blower design specified CFM into the Unit Controller. Make sure blower CFM is within limitations shown in TABLE 5 or TABLE 6.

RTU MENU > RTU OPTIONS > BLOWER > SPEED

- 2 - Enter the following design specifications as shown in TABLE 4.
 - Blower / Heat CFM
 - Cooling High CFM
 - Cooling Low CFM
 - Vent CFM

D-CFM Verification / Adjustment

The design CFM entered into the app for each blower speed should be verified, except for highest blower CFM. All adjustments will be made using ONLY the app.

- 1 - Run the each design CFM (blower speed) using the app.
- 2 - Measure Blower RPM and Static Pressure, then calculate the actual CFM per process in Section "Blower Operation and Adjustments".
- 3 - Adjust app entered design CFM (higher/lower) for this blower speed.
- 4 - Repeat steps 1-3 until actual CFM aligns with design CFM from Table 4.

E-Set Damper Minimum Position

To maintain required minimum ventilation air volumes when the unit is in the occupied mode, two minimum damper positions must be set.

The Unit Controller will open the damper to "Min OCP Blwr High" when blower CFM is at or ABOVE the "midpoint" CFM.

The Unit Controller will open the dampers to "Min OCP Blwr Low" when blower CFM is BELOW a "midpoint" CFM.

The Unit Controller will calculate the "midpoint" CFM.

TABLE 4
Blower CFM Design Specifications

Unit	T'Stat or Zone Control Stages	Blower Speed	Design Specified CFM
180	2	Htg.	
		Clg. High	
		Clg. Low	
		Ventilation	
210	2	Htg.	
		Clg. High	
		Clg. Low	
		Ventilation	
240	2	Htg.	
		Clg. High	
		Clg. Low	
		Ventilation	
300	2	Htg.	
		Clg. High	
		Clg. Low	
		Ventilation	

*Available blower speed vary by unit and thermostat stages.

Set Minimum Position 1

Use the following mobile service app menu to set "Min OCP Blwr High" for the blower CFM above the "midpoint" CFM. When navigating into this menu, the Unit Controller will run damper calibration and allow damper position adjustment.

RTU MENU > SETTINGS > RTU OPTIONS > DAMPER

Tap "Next" to skip tabs and complete damper position calibration until "Damper Calibration Blower Speed High" tab appears.

Measure the intake air CFM. If the CFM is lower than the design specified CFM for ventilation air, use the Unit Controller to increase the damper percent open. If the CFM is higher than specified, decrease the damper percent open.

NOTE - Intake air CFM can also be determined using the outdoor air temperature, return air temperature and mixed air temperature. Refer to the economizer or outdoor air damper installation instructions.

**TABLE 5
HEATING, VENTILATION, & SMOKE MINIMUM AND MAXIMUM CFM**

Tons	Unit			Heating CFM			Vent CFM			Smoke CFM		
	Model	Speed	Heat Code	Default	Min.	Max.	Default	Min.	Max.	Default	Min.	Max.
15	LGX180	Std	S	6000	4325	7200	6000	2250	7200	6000	2250	7200
		Med	M		4500							
		High	H		5125							
	LCX180	15, 30, 45, 60kW	N, E, J, K, L		5200							
17.5	LGX210	Std, Med	S, M	7000	4500	8400	7000	2625	8400	7000	2625	8400
		High	H		5125							
	LCX210	15, 30, 45, 60kW	N, E, J, K, L		5200							
		90kW	P		6000							
20	LGX240	Std, Med	S, M	8000	4500	9600	8000	3000	9600	8000	3000	9600
		High	H		5125							
	LCX240	15, 30, 45, 60kW	N, E, J, K, L		5200							
		90kW	P		6000							
25	LGX300	Std, Med	S, M	10000	4500	12000	10000	3750	12000	10000	3750	12000
		High	H		5125							
	LCX300	15, 30, 45, 60kW	N, E, J, K, L		5200							
		90kW	P		6000							

*Use highest value between Heating and Cooling High CFM Max.

**TABLE 6
COOLING MINIMUM AND MAXIMUM CFM**

LGX/ LCX Unit	Cooling Low CFM			Cooling High CFM		
	Default	Min.	Max.	Default	Min.	Max.
180	3900	2000	7200	5400	5000	7200
210	4550	2500	8400	6300	6000	8400
240	5200	3000	9600	7200	6250	9600
300	6500	3500	12000	9000	7000	12000

*Use Cooling High CFM Max

Set Minimum Position 2

Use the following mobile service app menu in the Unit Controller to set “Min OCP Blwr Low” for the blower CFM below the “midpoint” CFM. When navigating into this menu, the Unit Controller will run damper calibration and allow damper position adjustment.

RTU MENU > SETTINGS > RTU OPTIONS > DAMPER

Tap “Next” to skip tabs and complete damper position calibration until “Damper Calibration Blower Speed High” tab appears.

Measure the intake air CFM. If the CFM is lower than the design specified CFM for ventilation air, use the Unit Controller to increase the damper percent open. If the CFM is higher than specified, decrease the damper percent open.

NOTE - Intake air CFM can also be determined using the outdoor air temperature, return air temperature and mixed air temperature. Refer to the economizer or outdoor air damper installation instructions.

Blower Operation and Adjustments

Supply Air Staged Units - The blower rotation will always be correct on units equipped with an inverter. Checking blower rotation is not a valid method of determining voltage phasing for incoming power.

Supply Air Staged Units and Units Equipped With Optional Voltage or Phase Detection - The Unit Controller checks the incoming power during start-up. If the voltage or phase is incorrect, the Unit Controller will display an alarm and the unit will not start.

A-Blower Operation

Refer to the Unit Controller Setup Guide to energize blower. Use this mobile service app menu:

SERVICE > TEST > BLOWER

Instructions provided with the thermostat may also be used to initiate blower only (G) demand. Unit will cycle on thermostat demand. The following steps apply to applications using a typical electro-mechanical thermostat.

- 1 - Blower operation is manually set at the thermostat subbase fan switch. With fan switch in **ON** position, blowers will operate continuously.
- 2 - With fan switch in **AUTO** position, the blowers will cycle with demand. Blowers and entire unit will be off when system switch is in **OFF** position.

⚠ IMPORTANT

Three Phase Scroll Compressor Voltage Phasing

Three phase scroll compressors must be phased sequentially to ensure correct compressor and blower* rotation and operation. Compressor and blower are wired in phase at the factory. Power wires are color-coded as follows: line 1-red, line 2-yellow, line 3-blue.

- 1- Observe suction and discharge pressures and blower* rotation on unit start-up.
- 2- Suction pressure must drop, discharge pressure must rise, and blower* rotation must match rotation marking.

If pressure differential is not observed or blower* rotation is not correct:

- 3- Disconnect all remote electrical power supplies.
- 4- Reverse any two field-installed wires connected to the line side of S48 disconnect or TB13 terminal strip. Do not reverse wires at blower contactor.
- 5- Make sure the connections are tight.

Discharge and suction pressures should operate at their normal start-up ranges.

*Supply air VFD motors should rotate in the correct direction; verify scroll compressor rotation separately. Contact technical support if the VFD blower is rotating incorrectly.

⚠ WARNING

- 1- Make sure that unit is installed in accordance with the installation instructions and applicable codes.
- 2- Inspect all electrical wiring, both field and factory-installed, for loose connections. Tighten as required.
- 3- Check to ensure that refrigerant lines do not rub against the cabinet or against other refrigerant lines.
- 4- Check voltage at disconnect switch. Voltage must be within range listed on nameplate. If not, consult power company and have voltage condition corrected before starting unit.
- 5- Make sure filters are new and in place before start-up.

B-Blower Access

- 1 - Disconnect jack/plug connector to blower motor. Also disconnect jack/plug connector heating limit switches on gas units.
- 2 - Remove screws on either side of blower assembly sliding base. See FIGURE 17.
- 3 - Pull base toward outside of unit.

C-Determining Unit CFM

IMPORTANT - Multi-staged supply air units are factory-set to run the blower at full speed when there is a blower (G) demand without a heating or cooling demand. Refer to the field-provided, design specified CFM for all modes of operation. Use the following procedure to adjust motor pulley to deliver the highest CFM called for in the design spec. See Inverter Start-Up section to set blower CFM for all modes once the motor pulley is set.

- 1 - The following measurements must be made with a dry indoor coil. Run blower (G demand) without a cooling demand. Measure the indoor blower shaft RPM. Air filters must be in place when measurements are taken.
- 2 - With all access panels in place, measure static pressure external to unit (from supply to return). Blower performance data is based on static pressure readings taken in locations shown in FIGURE 16.

NOTE - Static pressure readings can vary if not taken where shown.

- 3 - Referring to page 24, use static pressure and RPM readings to determine unit CFM. Use page 25 when installing units with any of the optional accessories listed.
- 4 - The blower RPM can be adjusted at the motor pulley. Loosen Allen screw and turn adjustable pulley clockwise to increase CFM. Turn counterclockwise to decrease CFM. See FIGURE 17. Do not exceed minimum and maximum number of pulley turns as shown in TABLE 7.

TABLE 7

MINIMUM AND MAXIMUM PULLEY ADJUSTMENT

Belt	Min. Turns Open	Max. Turns Open
A Section	No minimum	5
B Section	1*	6

*No minimum number of turns open when B belt is used on pulleys 6" O.D. or larger.

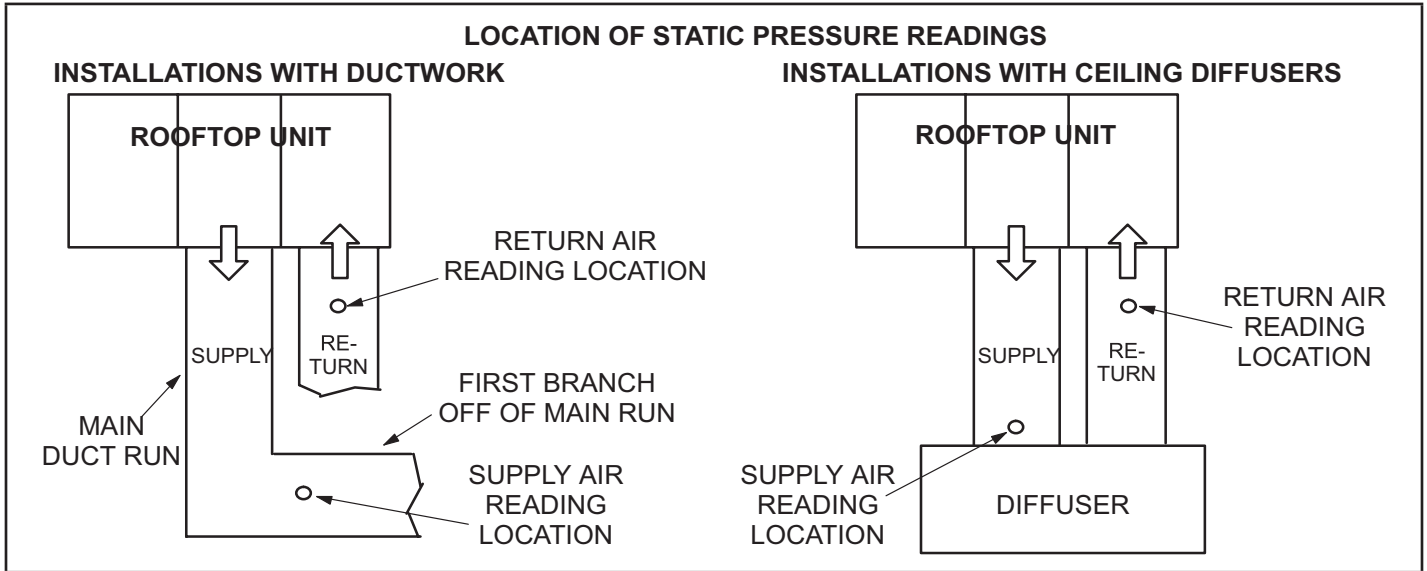

FIGURE 16

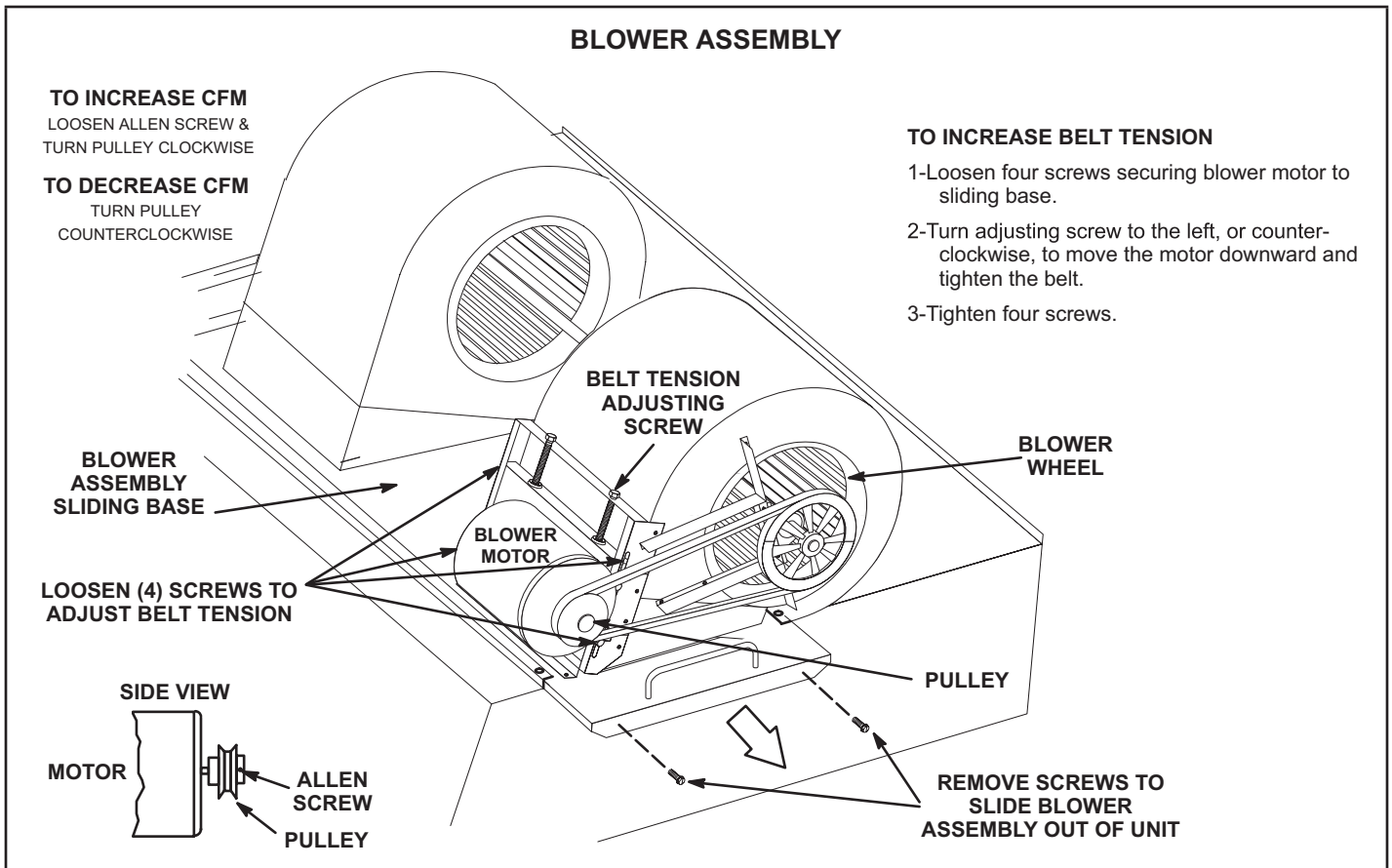

FIGURE 17

D-Blower Belt Adjustment

Maximum life and wear can be obtained from belts only if proper pulley alignment and belt tension are maintained. Tension new belts after a 24-48 hour period of operation. This will allow belt to stretch and seat into pulley grooves. Make sure blower and motor pulley are aligned. See FIGURE 18.

- 1 - Loosen four screws securing blower motor to sliding base. See FIGURE 17.
- 2 - To increase belt tension -
Turn belt tension adjusting screw to the left, or counterclockwise, to tighten the belt. This increases the distance between the blower motor and the blower housing.
To loosen belt tension -
Turn the adjusting screw to the right, or clockwise to loosen belt tension.
- 3 - Tighten four screws securing blower motor to sliding base once adjustments have been made.

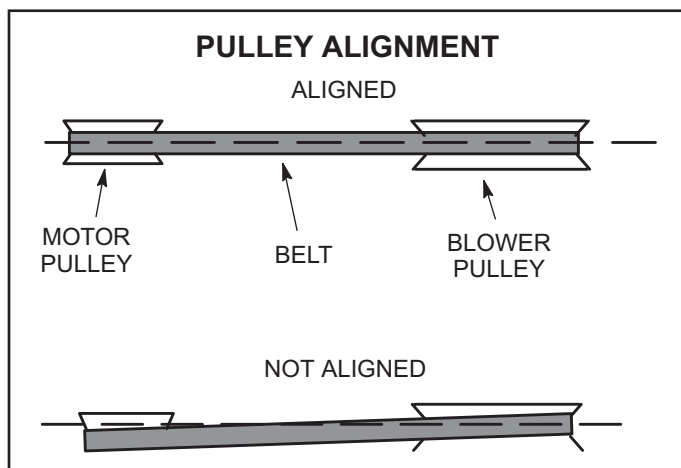

FIGURE 18

E-Check Belt Tension

Overtensioning belts shortens belt and bearing life. Check belt tension as follows:

- 1 - Measure span length X. See FIGURE 19.
- 2 - Apply perpendicular force to center of span (X) with enough pressure to deflect belt 1/64" for every inch of span length or 1.5mm per 100mm of span length.
Example: Deflection distance of a 40" span would be 40/64" or 5/8".
Example: Deflection distance of a 400mm span would be 6mm.
- 3 - Measure belt deflection force. For a used belt, the deflection force should be 5 lbs. (35kPa) . A new belt deflection force should be 7 lbs. (48kPa).

A force below these values indicates and undertensioned belt. A force above these values indicates an overtensioned belt.

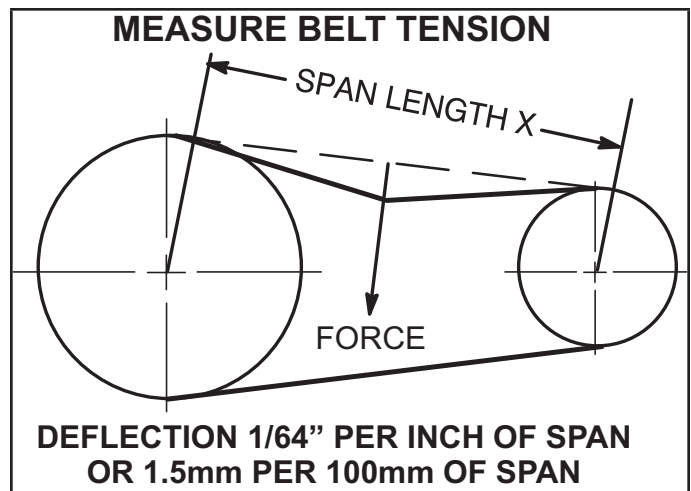

FIGURE 19

F-Field-Furnished Blower Drives

For field-furnished blower drives, use page 24 to determine BHP and RPM required. Reference page 26 to determine the manufacturer's model number.

G-Minimum Airflow For Electric Heat (Field Installed Option)

Electric Heat kW	Minimum CFM
15	5200
30	5200
45	5200
60	5200
90	6000

BLOWER DATA

BLOWER TABLE INCLUDES RESISTANCE FOR BASE UNIT ONLY WITH DRY INDOOR COIL & AIR FILTERS IN PLACE.

FOR ALL UNITS ADD: 1 - Wet indoor coil air resistance of selected unit. 2 - Any factory installed options air resistance (heat section, economizer, etc.) 3 - Any field installed accessories air resistance (heat section, duct resistance, diffuser, etc.).

Then determine from blower table blower motor output and drive required.

See page 25 for wet coil, option/accessory air resistance data, and factory installed drive kit specifications.

MINIMUM AIR VOLUME REQUIRED FOR DIFFERENT GAS HEAT SIZES:

Low, Standard and Medium Heat - 4500 cfm minimum; High Heat - 5125 cfm

MINIMUM AIR VOLUME REQUIRED FOR USE WITH OPTIONAL ELECTRIC HEAT:

LCX units with 15-60KW electric heat require 5200 cfm minimum air; units with 90KW require 6000 cm minimum air.

Air Volume cfm	TOTAL STATIC PRESSURE - Inches Water Gauge (Pa)																										
	0.20		0.40		0.60		0.80		1.00		1.20		1.40		1.60		1.80		2.00		2.20		2.40		2.60		
	RPM	BHP	RPM	BHP	RPM	BHP	RPM	BHP	RPM	BHP	RPM	BHP	RPM	BHP	RPM	BHP	RPM	BHP	RPM	BHP	RPM	BHP	RPM	BHP	RPM	BHP	RPM
2750	385	0.30	0.50	600	0.70	680	0.90	755	1.10	820	1.30	885	1.70	950	2.10	1005	2.550	1110	3.00	1110	3.30	---	---	---	---	---	
3000	395	0.35	0.55	610	0.75	685	1.00	760	1.20	825	1.45	885	1.70	950	2.10	1005	2.550	1110	3.00	1110	3.30	---	---	---	---	---	
3250	405	0.40	0.60	615	0.85	695	1.10	765	1.30	830	1.60	890	1.85	950	2.25	1005	2.550	1110	3.00	1110	3.30	---	---	---	---	---	
3500	415	0.45	0.70	620	0.95	700	1.20	775	1.45	840	1.70	900	2.00	950	2.25	1005	2.550	1110	3.00	1110	3.30	---	---	---	---	---	
3750	425	0.50	0.75	630	1.05	710	1.30	780	1.60	845	1.85	905	2.15	960	2.45	1010	2.700	1110	3.00	1110	3.30	---	---	---	---	---	
4000	435	0.55	0.85	635	1.10	715	1.40	785	1.70	850	2.00	910	2.30	965	2.60	1020	2.900	1110	3.00	1110	3.30	---	---	---	---	---	
4250	445	0.60	0.90	645	1.25	725	1.55	795	1.85	855	2.15	915	2.45	970	2.80	1025	3.100	1110	3.00	1110	3.30	---	---	---	---	---	
4500	455	0.70	1.00	655	1.35	730	1.65	800	2.00	865	2.35	925	2.65	980	3.00	1030	3.300	1110	3.00	1110	3.30	---	---	---	---	---	
4750	470	0.75	1.10	660	1.45	740	1.80	810	2.15	870	2.50	930	2.85	985	3.20	1040	3.500	1110	3.00	1110	3.30	---	---	---	---	---	
5000	480	0.85	1.25	670	1.60	750	1.95	815	2.30	880	2.70	940	3.05	995	3.40	1045	3.800	1110	3.00	1110	3.30	---	---	---	---	---	
5250	495	0.95	1.35	680	1.70	755	2.10	825	2.50	890	2.90	945	3.25	1000	3.65	1050	4.000	1110	3.00	1110	3.30	---	---	---	---	---	
5500	505	1.05	1.45	690	1.85	765	2.25	835	2.65	895	3.05	955	3.45	1010	3.85	1060	4.250	1110	3.00	1110	3.30	---	---	---	---	---	
5750	520	1.15	1.60	700	2.00	775	2.45	840	2.85	905	3.25	960	3.65	1015	4.10	1065	4.500	1110	3.00	1110	3.30	---	---	---	---	---	
6000	530	1.30	1.75	710	2.15	785	2.60	850	3.05	910	3.45	970	3.90	1025	4.35	1075	4.800	1110	3.00	1110	3.30	---	---	---	---	---	
6250	545	1.40	1.90	720	2.35	795	2.80	860	3.25	920	3.70	975	4.15	1030	4.60	1080	5.050	1110	3.00	1110	3.30	---	---	---	---	---	
6500	560	1.55	2.05	730	2.50	805	3.00	870	3.45	930	3.95	985	4.40	1040	4.85	1090	5.350	1110	3.00	1110	3.30	---	---	---	---	---	
6750	570	1.70	2.20	745	2.70	815	3.20	880	3.70	940	4.20	995	4.65	1045	5.10	1095	5.600	1110	3.00	1110	3.30	---	---	---	---	---	
7000	585	1.85	2.35	755	2.90	825	3.40	890	3.95	950	4.45	1005	4.95	1055	5.40	1105	5.950	1110	3.00	1110	3.30	---	---	---	---	---	
7250	600	2.00	2.60	765	3.10	835	3.65	900	4.15	955	4.65	1015	5.25	1065	5.75	1115	6.250	1110	3.00	1110	3.30	---	---	---	---	---	
7500	615	2.20	2.75	775	3.30	845	3.85	910	4.45	965	4.95	1020	5.50	1075	6.05	1125	6.600	1110	3.00	1110	3.30	---	---	---	---	---	
7750	630	2.40	3.00	790	3.55	855	4.10	920	4.70	975	5.25	1030	5.80	1080	6.35	1130	6.900	1110	3.00	1110	3.30	---	---	---	---	---	
8000	640	2.55	3.20	800	3.80	865	4.35	930	4.95	985	5.50	1040	6.10	1090	6.70	1140	7.250	1110	3.00	1110	3.30	---	---	---	---	---	
8250	655	2.80	3.40	810	4.00	880	4.65	940	5.25	995	5.85	1050	6.45	1100	7.05	1150	7.650	1110	3.00	1110	3.30	---	---	---	---	---	
8500	670	3.00	3.65	825	4.30	890	4.90	950	5.55	1005	6.15	1060	6.80	1110	7.40	1160	8.050	1110	3.00	1110	3.30	---	---	---	---	---	
8750	685	3.25	3.90	835	4.55	900	5.20	960	5.85	1015	6.45	1070	7.15	1120	7.75	1165	8.350	1110	3.00	1110	3.30	---	---	---	---	---	
9000	700	3.50	4.20	850	4.85	910	5.50	970	6.15	1025	6.80	1080	7.50	1130	8.15	1175	8.750	1110	3.00	1110	3.30	---	---	---	---	---	
9250	715	3.75	4.45	860	5.15	925	5.85	985	6.55	1040	7.20	1090	7.85	1140	8.55	1185	9.200	1110	3.00	1110	3.30	---	---	---	---	---	
9500	730	4.00	4.75	875	5.45	935	6.15	995	6.90	1050	7.60	1100	8.25	1150	8.95	1195	9.600	1110	3.00	1110	3.30	---	---	---	---	---	
9750	745	4.30	5.05	885	5.75	950	6.55	1005	7.20	1060	7.95	1110	8.65	1160	9.40	1205	10.05	1110	3.00	1110	3.30	---	---	---	---	---	
10,000	760	4.60	5.40	900	6.15	960	6.85	1015	7.60	1070	8.35	1120	9.05	1170	9.80	1215	10.50	1110	3.00	1110	3.30	---	---	---	---	---	
10,250	775	4.90	5.65	910	6.45	970	7.20	1030	8.00	1080	8.75	1135	9.55	1180	10.25	1225	11.00	1110	3.00	1110	3.30	---	---	---	---	---	
10,500	790	5.20	6.00	925	6.85	985	7.65	1040	8.40	1095	9.20	1145	10.00	1190	10.75	1235	11.50	1110	3.00	1110	3.30	---	---	---	---	---	
10,750	805	5.55	6.40	940	7.25	1000	8.05	1055	8.85	1105	9.65	1155	10.45	1200	11.25	1245	12.00	1110	3.00	1110	3.30	---	---	---	---	---	
11,000	820	5.90	6.80	950	7.60	1010	8.45	1065	9.30	1115	10.05	1165	10.85	1210	11.75	1255	12.50	1110	3.00	1110	3.30	---	---	---	---	---	

BLOWER DATA

FACTORY INSTALLED BELT DRIVE KIT SPECIFICATIONS

Nominal hp	Maximum hp	Drive Kit Number	RPM Range
2	2.30	1	535 - 725
2	2.30	2	710 - 965
3	3.45	1	535 - 725
3	3.45	2	710 - 965
5	5.75	3	685 - 856
5	5.75	4	850 - 1045
5	5.75	5	945 - 1185
7.5	8.63	6	850 - 1045
7.5	8.63	7	945 - 1185
7.5	8.63	8	1045 - 1285
10	11.50	7	945 - 1185
10	11.50	10	1045 - 1285
10	11.50	11	1105-1330

NOTE - Using total air volume and system static pressure requirements determine from blower performance tables rpm and motor output required. Maximum usable output of motors furnished are shown. In Canada, nominal motor output is also maximum usable motor output. If motors of comparable output are used, be sure to keep within the service factor limitations outlined on the motor nameplate.

NOTE - All units are limited to a motor service factor of 1.0.

FACTORY INSTALLED OPTIONS/FIELD INSTALLED ACCESSORY AIR RESISTANCE

Air Volum cfm	Wet Indoor Coil		Gas Heat Exchanger			Econo- mizer	Filters			Horizontal Roof Curb	
	180	210, 240, 300	Std. Heat	Medium Heat	High Heat		MERV 8	MERV 13	MERV 16	180-240	300
2750	0.01	0.02	0.02	0.04	0.05	---	0.01	0.03	0.06	0.03	---
3000	0.01	0.02	0.03	0.04	0.05	---	0.01	0.03	0.06	0.04	---
3250	0.01	0.03	0.03	0.05	0.06	---	0.01	0.04	0.07	0.04	0.01
3500	0.01	0.03	0.03	0.05	0.06	---	0.01	0.04	0.08	0.05	0.01
3750	0.01	0.03	0.04	0.06	0.07	---	0.01	0.04	0.08	0.05	0.01
4000	0.02	0.04	0.04	0.06	0.07	---	0.01	0.04	0.09	0.06	0.02
4250	0.02	0.04	0.04	0.06	0.08	---	0.01	0.05	0.1	0.07	0.02
4500	0.02	0.05	0.05	0.07	0.09	---	0.01	0.05	0.1	0.07	0.02
4750	0.02	0.05	0.05	0.08	0.1	---	0.02	0.05	0.11	0.08	0.03
5000	0.02	0.05	0.05	0.09	0.11	---	0.02	0.06	0.12	0.08	0.03
5250	0.02	0.06	0.06	0.1	0.12	---	0.02	0.06	0.12	0.09	0.04
5500	0.02	0.07	0.06	0.1	0.13	---	0.02	0.06	0.13	0.1	0.04
5750	0.03	0.07	0.06	0.11	0.14	---	0.02	0.07	0.14	0.11	0.05
6000	0.03	0.08	0.07	0.12	0.15	---	0.03	0.07	0.14	0.11	0.06
6250	0.03	0.08	0.07	0.12	0.16	0.01	0.03	0.07	0.15	0.12	0.07
6500	0.03	0.09	0.08	0.13	0.17	0.02	0.03	0.08	0.16	0.13	0.08
6750	0.04	0.1	0.08	0.14	0.18	0.03	0.03	0.08	0.17	0.14	0.08
7000	0.04	0.1	0.09	0.15	0.19	0.04	0.04	0.08	0.17	0.15	0.09
7250	0.04	0.11	0.09	0.16	0.2	0.05	0.04	0.09	0.18	0.16	0.1
7500	0.05	0.12	0.1	0.17	0.21	0.06	0.04	0.09	0.19	0.17	0.11
8000	0.05	0.13	0.11	0.19	0.24	0.09	0.05	0.1	0.21	0.19	0.13
8500	0.06	0.15	0.12	0.2	0.26	0.11	0.05	0.1	0.22	0.21	0.15
9000	0.07	0.16	0.13	0.23	0.29	0.14	0.06	0.11	0.24	0.24	0.17
9500	0.08	0.18	0.14	0.25	0.32	0.16	0.07	0.12	0.25	0.26	0.19
10,000	0.08	0.2	0.16	0.27	0.35	0.19	0.07	0.12	0.27	0.29	0.21
10,500	0.09	0.22	0.17	0.3	0.38	0.22	0.08	0.13	0.29	0.31	0.24
11,000	0.11	0.24	0.18	0.31	0.4	0.25	0.09	0.14	0.3	0.34	0.27

**TABLE 8
MANUFACTURER'S NUMBERS**

Drive No.	H.P.	DRIVE COMPONENTS													
		RPM		ADJUSTABLE SHEAVE		FIXED SHEAVE		BELTS (STD.)		BELTS (WITH TENSIONER)		SPLIT BUSHING			
		Min	Max	Supplier No.	OEM Part No.	Supplier No.	OEM Part No.	Supplier No.	OEM Part No.	Supplier No.	OEM Part No.	Supplier No.	OEM Part No.		
1	2, 3	535	725	1VP40X7/8	79J0301	BK95 x 1-3/16	105617-02	BX59	59A5001	BX60	100245-10	N/A	N/A	N/A	
2	2, 3	710	965	1VP40X7/8	79J0301	BK72 x 1-3/16	105617-01	BX55	63K0501	BX57	78L5301	N/A	N/A	N/A	
3	5	685	865	1VP50X1-1/8	P-8-1977	BK100 x 1-3/16	105617-03	BX61	93J9801	5VX660	100245-20	N/A	N/A	N/A	
4	5	850	1045	1VP65X1-1/8	100239-03	BK110H	100788-06	BX65	100245-08	BX66	97J5901	H-1-3/16	105616-02	105616-02	
5	5	945	1185	1VP60X1-1/8	41C1301	BK90H x 1-7/16	100788-04	BX61	93J9801	BX62	57A7701	H-1-3/16	105616-02	105616-02	
6	7.5	850	1045	1VP65X1-3/8	78M7101	BK110H	100788-06	BX66	97J5901	BX67	100245-09	H-1-3/16	105616-02	105616-02	
7	7.5 & 10	945	1185	1VP60X1-3/8	78L5501	BK90H x 1-7/16	100788-04	BX62	57A7701	BX64	97J5801	H-1-3/16	105616-02	105616-02	
8	7.5	1045	1285	1VP65X1-3/8	78M7101	BK90H x 1-7/16	100788-04	BX64	97J5801	5VX670	100245-21	H-1-3/16	105616-02	105616-02	
10	10	1045	1285	1VP65X1-3/8	78M7101	1B5V86	78M8301	5VX660	100245-20	5VX670	100245-21	B-1-3/16	105616-01	105616-01	
11	10	1135	1330	1VP71X1-3/8	100239-06	1B5V90	100240-02	5VX680	100245-35	5VX680	100245-35	B-1-3/16	105616-01	105616-01	

Refrigerant Leak Detection System

A-System Test

- 1 - Initiate Refrigerant Leak Detection System Test by using the following mobile service app menu path:

RTU MENU > COMPONENT TEST > LEAK DETECTION > START TEST

- 2 - Ensure that indoor blower, outdoor fan, and combustion air blower (LGX only) are energized.

Cooling Start-Up

IMPORTANT - The crankcase heater must be energized for 24 hours before attempting to start compressor. Set thermostat so there is no demand to prevent compressors from cycling. Apply power to unit.

NOTE - These units must not be used as a "construction heater" at any time during any phase of construction. Very low return air temperatures, harmful vapors and misplacement of the filters will damage the unit and its efficiency. Additionally, a unit which will be subject to cold temperatures when not in operation must have a vapor barrier installed to seal the duct connections. Failure to protect the unit from moisture laden air or harmful vapors (generated from the construction process and temporary combustion heating equipment) will cause corrosive condensation within the unit. Failure to properly protect the unit in this situation will cause electrical and electronic component failure and could affect the unit warranty status.

A-Preliminary Checks

- 1 - Make sure that unit is installed in accordance with the installation instructions and applicable codes.
- 2 - Inspect all electrical wiring, both field and factory-installed, for loose connections. Tighten as required.
- 3 - Check to ensure that refrigerant lines do not rub against the cabinet or against other refrigerant lines.
- 4 - Check voltage at disconnect switch. Voltage must be within range listed on nameplate. If not, consult power company and have voltage condition corrected before starting unit.
- 5 - Make sure filters are in place before start-up.

B-Start-Up

- 1 - Initiate first and second stage cooling demands using this mobile service app menu path:

SERVICE > TEST > COOLING

Instructions provided with the thermostat may also be used to initiate cooling.

- 2 - First-stage thermostat demand will energize indoor blower in Low Cooling CFM and associated first-stage compressors. Second-stage thermostat demand will energize indoor blower in High Cooling CFM and all remaining compressors.

- 3 - 180, 210, 240 -

Units contain three refrigerant circuits or systems. See FIGURE 20.

300 -

Units contain four refrigerant circuits or systems. See FIGURE 21.

- 4 - Each refrigerant circuit is separately charged with R454B refrigerant. See unit rating plate for correct amount of charge.
- 5 - Refer to the Refrigerant Check and Charge section to check refrigerant charge.

C-R454B Refrigerant

Units charged with R454B refrigerant operate at lower pressures than R410A. The expansion valve and liquid line dryer provided with the unit are approved for use with R454B.

R454B refrigerant is stored in a gray cylinder.

CAUTION

Mineral oils are not compatible with R454B. If oil must be added, it must be a polyolester oil.

Manifold gauge sets used with systems charged with R454B refrigerant must be capable of handling various system operating pressures. The gauges should be rated for use with pressures of 0-800 on the high side and a low side of 30" vacuum to 250 psi with dampened speed to 500 psi. Gauge hoses must be rated for use at up to 800 psi of pressure with a 4000 psi burst rating.

In addition to conventional charging procedures, the following requirements shall be followed.

- Ensure that contamination of different refrigerants does not occur when using charging equipment. Hoses or lines shall be as short as possible to minimize the amount of refrigerant contained in them.
- Cylinders shall be kept in an appropriate position according to the instructions.
- Ensure that the unit is earth grounded prior to charging the system with refrigerant.
- Label the system when charging is complete (if not already).
- Extreme care shall be taken not to overfill the unit.

Prior to recharging the system, it shall be pressure-tested with the appropriate purging gas. The system shall be leak-tested on completion of charging but prior to commissioning. A follow up leak test shall be carried out prior to leaving the site.

- When removing refrigerant from a system, either for servicing or decommissioning, it is a recommended good practice that all refrigerants are removed safely.

- When transferring refrigerant into cylinders, ensure that only appropriate refrigerant recovery cylinders are employed. Ensure that the correct number of cylinders for holding the total system charge is available. All cylinders to be used are designated for the recovered refrigerant and labelled for that refrigerant (i. e. special cylinders for the recovery of refrigerant). Cylinders shall be complete with pressure-relief valve and associated shut-off valves in good working order. Empty recovery cylinders are evacuated and, if possible, cooled before recovery
- The recovery equipment shall be in good working order with a set of instructions concerning the equipment that is at hand and shall be suitable for the recovery of all appropriate refrigerants including, when applicable, flammable refrigerants. In addition, a set of calibrated weighing scales shall be available and in good working order. Hoses shall be complete with leak-free disconnect couplings and in good condition. Before using the recovery machine, check that it is in satisfactory working order, has been properly maintained and that any associated electrical components are sealed to prevent ignition in the event of a refrigerant release. Consult manufacturer if in doubt.
- The recovered refrigerant shall be returned to the refrigerant supplier in the correct recovery cylinder, and the relevant waste transfer note arranged. Do not mix refrigerants in recovery units and especially not in cylinders.
- If compressors or compressor oils are to be removed, ensure that they have been evacuated to an acceptable level to make certain that flammable refrigerant does not remain within the lubricant. The evacuation process shall be carried out prior to returning the compressor to the suppliers. Only electric heating to the compressor body shall be employed to accelerate this process. When oil is drained from a system, it shall be carried out safely.

NOTE - System charging is not recommended below 60°F (15°C). In temperatures below 60°F (15°C), the charge must be weighed into the system.

If weighing facilities are not available, or to check the charge, use the following procedure:

- 1 - Make sure outdoor coil is clean. Attach gauge manifolds and operate unit at full CFM in cooling mode with economizer disabled until system stabilizes (approximately five minutes). Make sure all outdoor air dampers are closed.
- 2 - Compare the normal operating pressures to the pressures obtained from the gauges. Check unit components if there are significant differences.
- 3 - Measure the outdoor ambient temperature and the suction pressure. Refer to the charging curve to determine a target liquid temperature.

180S, 210S UNITS - THREE REFRIGERANT CIRCUITS

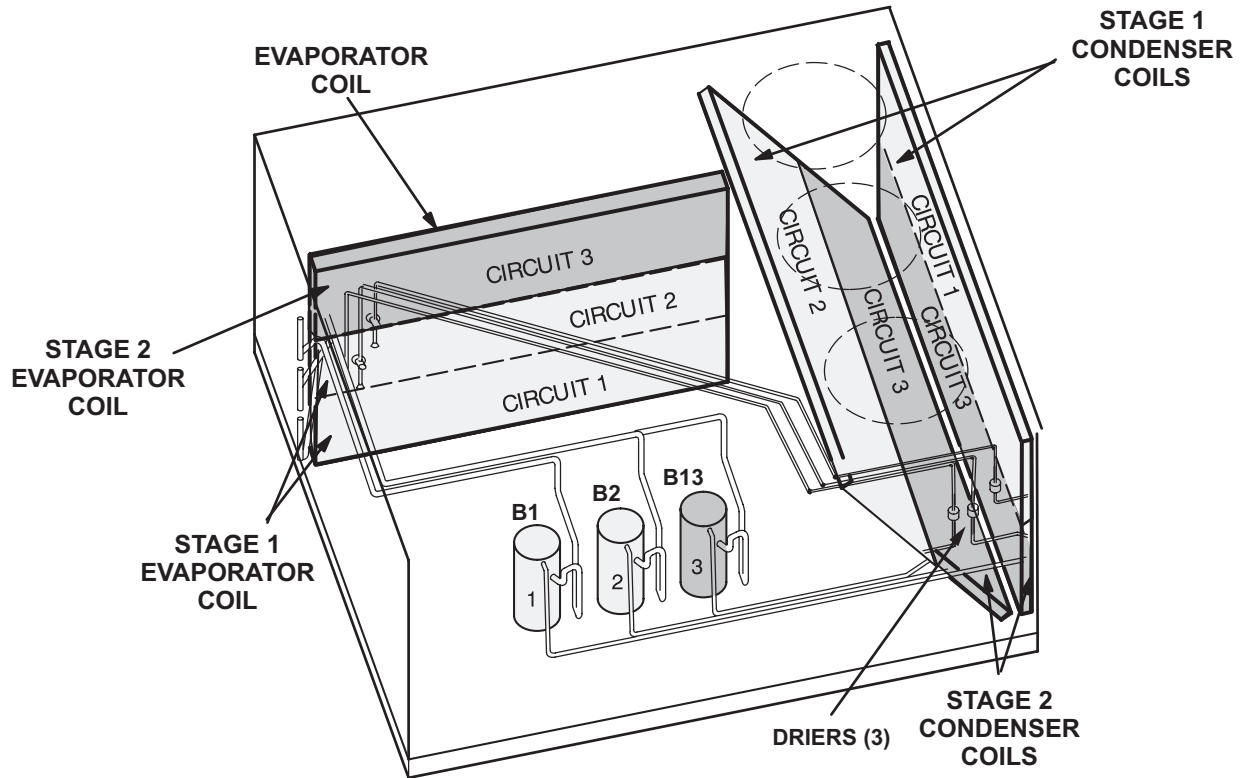

FIGURE 20

240S - THREE REFRIGERANT CIRCUITS

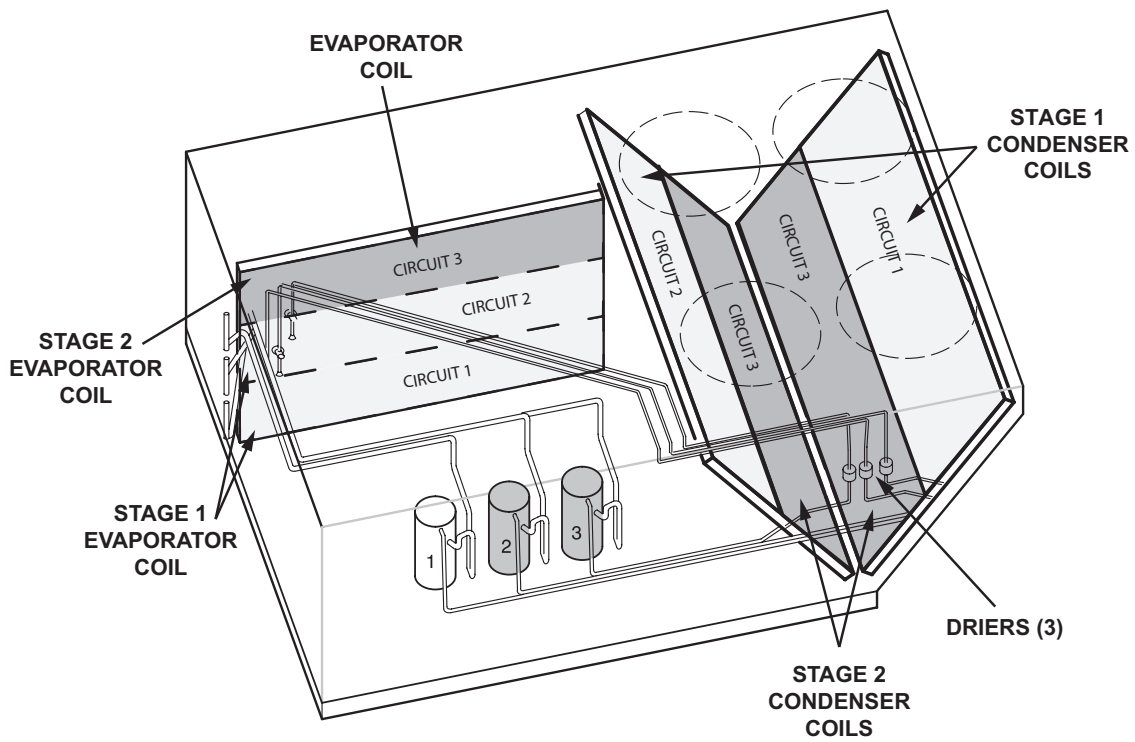

FIGURE 21

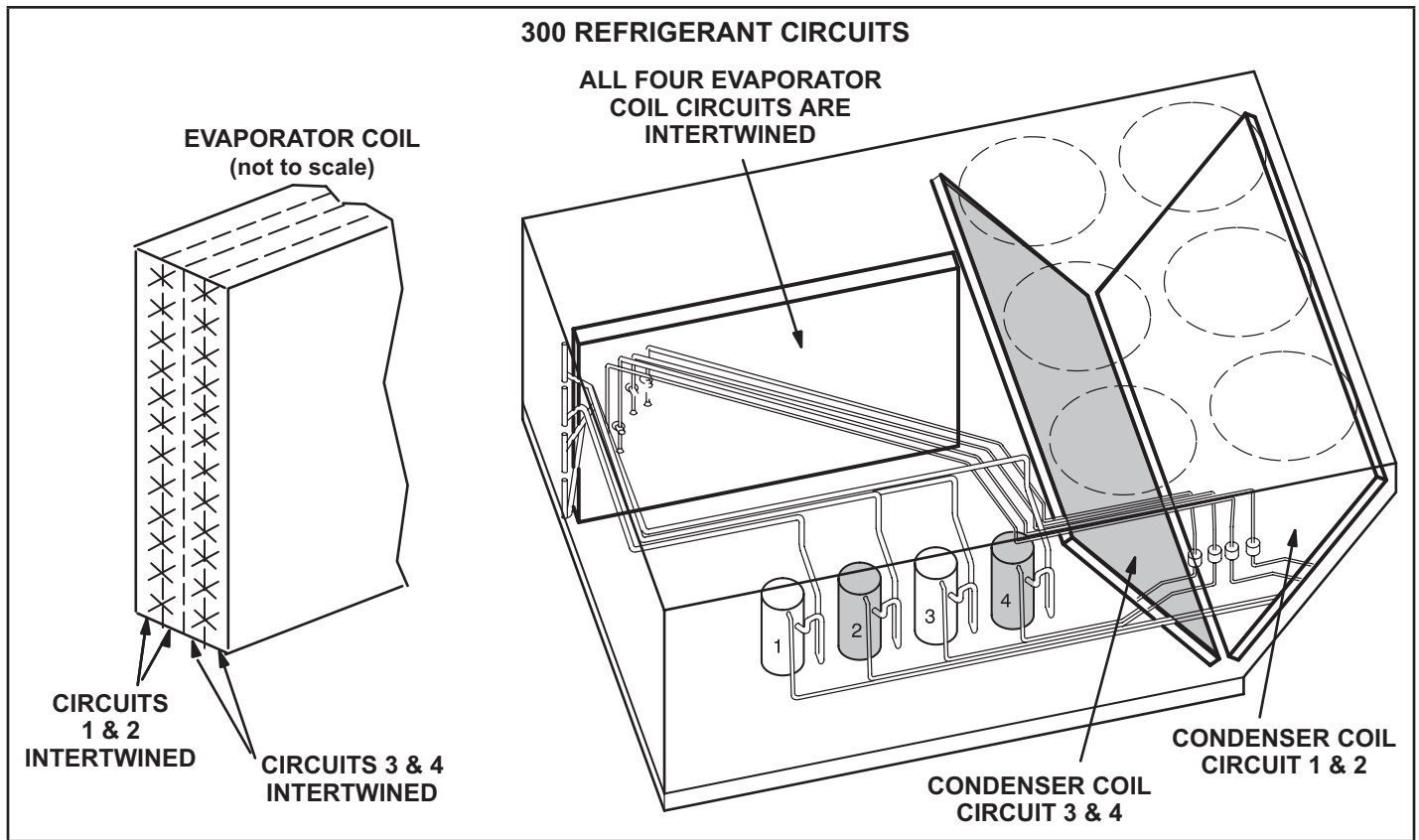

FIGURE 22

D-Refrigerant Charge and Check - All Aluminum Coil

WARNING-Do not exceed nameplate charge under any condition.

This unit is factory charged and should require no further adjustment. If the system requires additional refrigerant, reclaim the charge, evacuate the system, and add required nameplate charge.

NOTE - System charging is not recommended below 60°F (15°C). In temperatures below 60°F (15°C), the charge must be weighed into the system.

If weighing facilities are not available, or to check the charge, use the following procedure:

IMPORTANT - Charge unit in normal cooling mode.

- 1 - Attach gauge manifolds to discharge and suction lines. With the economizer disabled, operate the unit in **cooling mode at high speed** using the following mobile service app menu path:

SERVICE>TEST>COOL

- 2 - Use a thermometer to accurately measure the outdoor ambient temperature.
- 3 - Apply the outdoor temperature to TABLE 9 through TABLE 12 to determine normal operating pressures. Pressures are listed for sea level applications at 80°F dry bulb and 67°F wet bulb return air.
- 4 - Compare the normal operating pressures to the pressures obtained from the gauges. Minor variations in the pressures may be expected due to differences in installations. Significant differences could mean that the system is not properly charged or that a problem exists with some component in the system. **Correct any system problems before proceeding.**
- 5 - If discharge pressure is high, remove refrigerant from the system. If discharge pressure is low, add refrigerant to the system.
 - Add or remove charge in increments.
 - Allow the system to stabilize each time refrigerant is added or removed.
- 6 - Confirm charge amount using liquid temperature plots. Fine tune charge amount(s) to match liquid temperature plots as needed per the next section.

E-Charge Confirmation and Fine Tuning - Liquid Temperature Check

NOTE - Pressures are listed for sea level applications.

- 1 - Use the same thermometer to accurately measure the liquid temperature (in the outdoor section).
 - If measured liquid temperature is higher than the target liquid temperature, add refrigerant to the system.
 - If measured liquid temperature is lower than the target liquid temperature, recover some refrigerant from the system. Add or remove charge in increments. Allow the system to stabilize each time refrigerant is added or removed.
- 2 - Continue the process until measured liquid temperature agrees with the target liquid temperature. Do not go below the target liquid temperature when adjusting charge. Note that suction pressure can change as charge is adjusted.

Example: For the 180 model at 95°F outdoor ambient and a measured suction pressure of 130psig, the target liquid temperature is 100°F. For a measured liquid temperature of 106°F, add charge in increments until measured liquid temperature agrees with the target liquid temperature.

TABLE 9
LGX/LCX 180 NO REHEAT NORMAL OPERATING PRESSURES - ALL-ALUMINUM COIL - 581137-02

Outdoor Coil Entering Air Temperature												
	65°F		75°F		85°F		95°F		105°F		115°F	
	Suct (psig)	Disc (psig)	Suct (psig)	Disc (psig)	Suct (psig)	Disc (psig)	Suct (psig)	Disc (psig)	Suct (psig)	Disc (psig)	Suct (psig)	Disc (psig)
Circuit 1	106	224	107	261	109	303	111	351	112	403	113	460
	113	227	115	264	117	306	119	353	120	405	122	462
	130	234	132	270	135	312	137	358	139	409	141	466
	149	240	151	276	154	317	156	363	159	414	161	470
Circuit 2	105	231	106	269	108	312	110	360	112	413	114	471
	112	234	114	272	116	315	118	363	120	415	122	473
	129	241	131	279	133	321	135	369	138	421	140	478
	149	250	151	287	153	329	155	376	157	428	160	485
Circuit 3	105	249	106	289	108	336	110	388	112	445	114	509
	112	252	114	292	116	338	118	390	120	447	122	511
	130	261	132	300	133	345	135	396	138	453	140	515
	150	270	151	309	153	353	155	404	158	460	160	522

180 CHARGING CURVE CIRCUIT 1 - ALL-ALUMINUM COIL - 581136-02

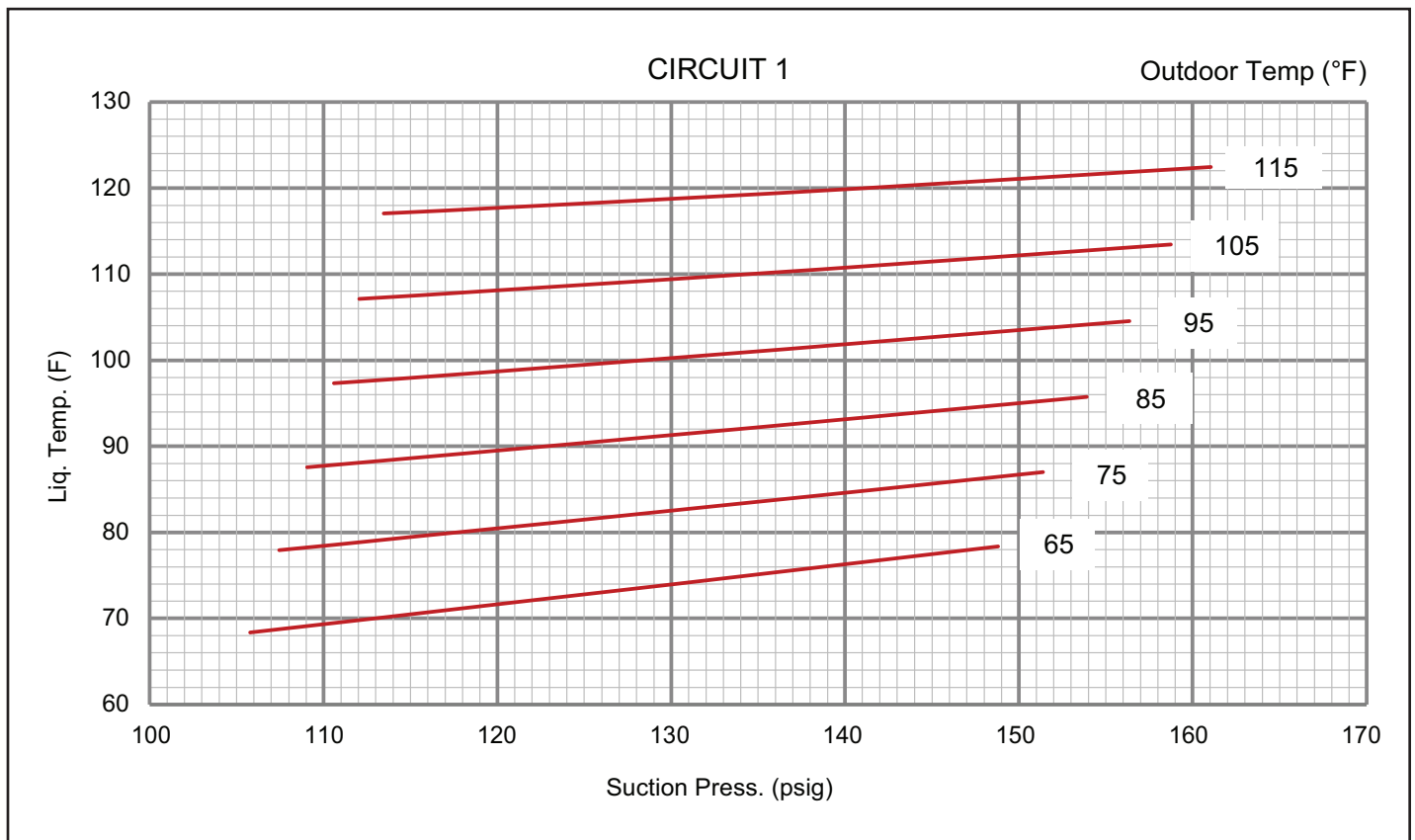

180 CHARGING CURVE CIRCUIT 2 - ALL-ALUMINUM COIL - 581136-02

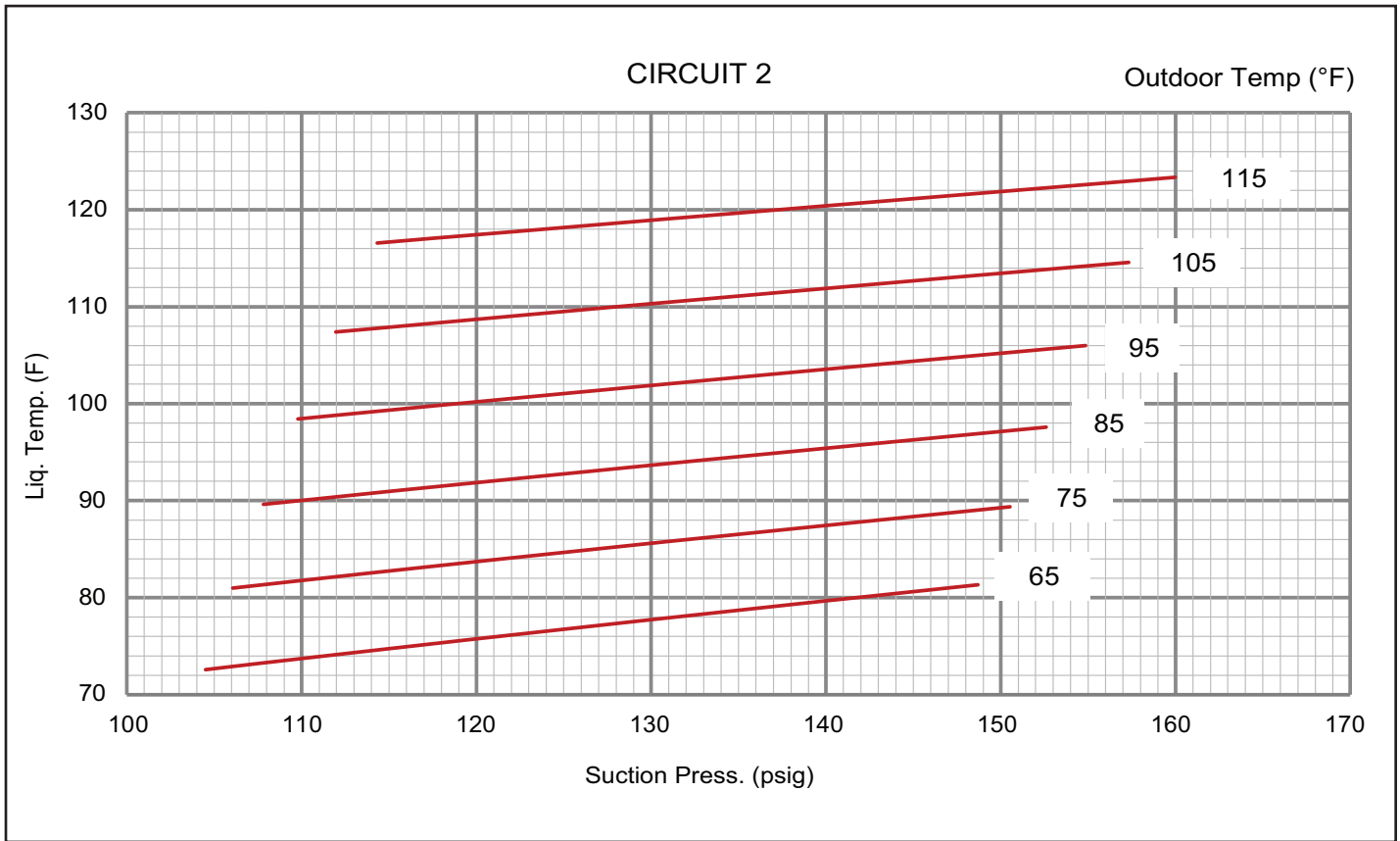

180 CHARGING CURVE CIRCUIT 3 - ALL-ALUMINUM COIL - 581136-02

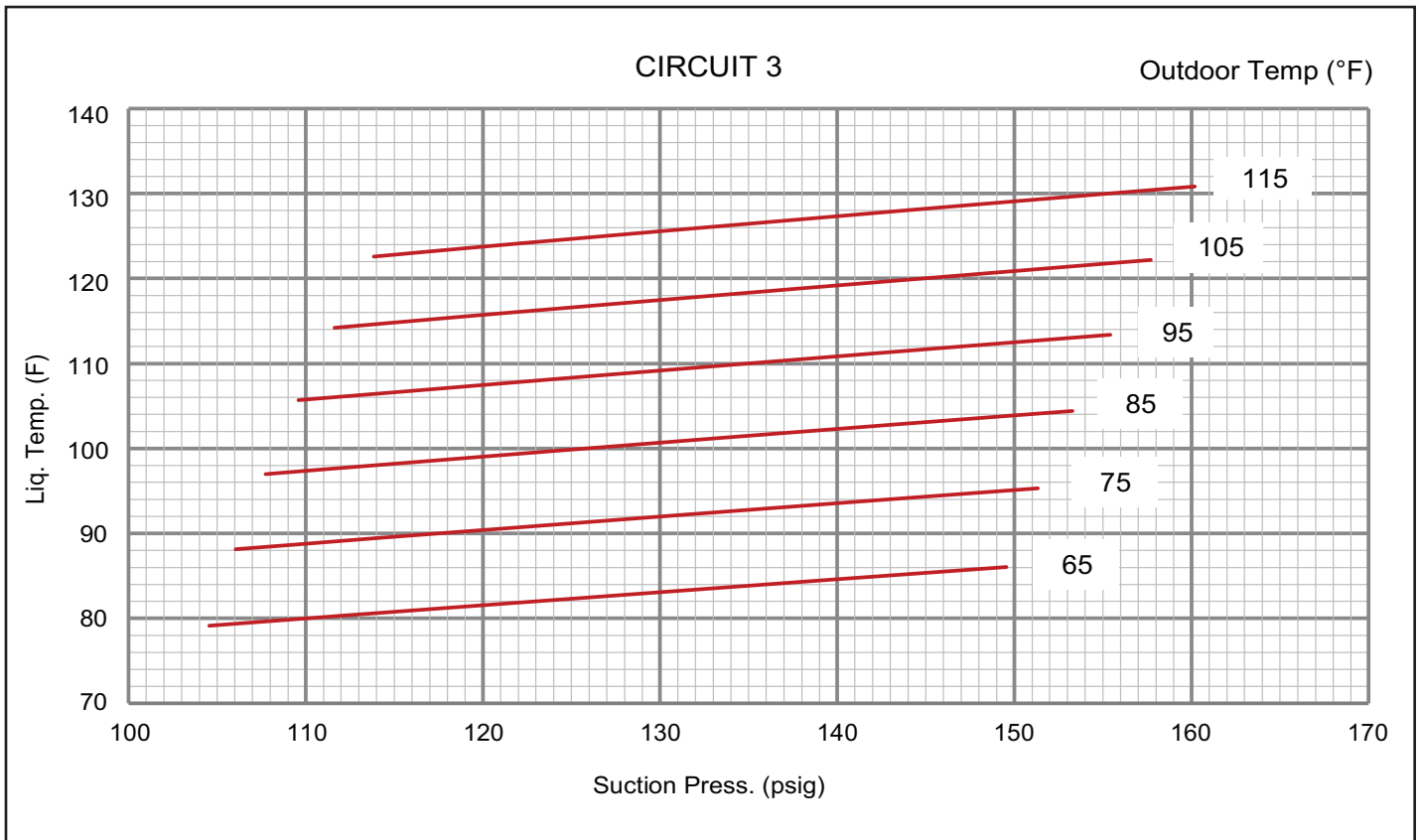
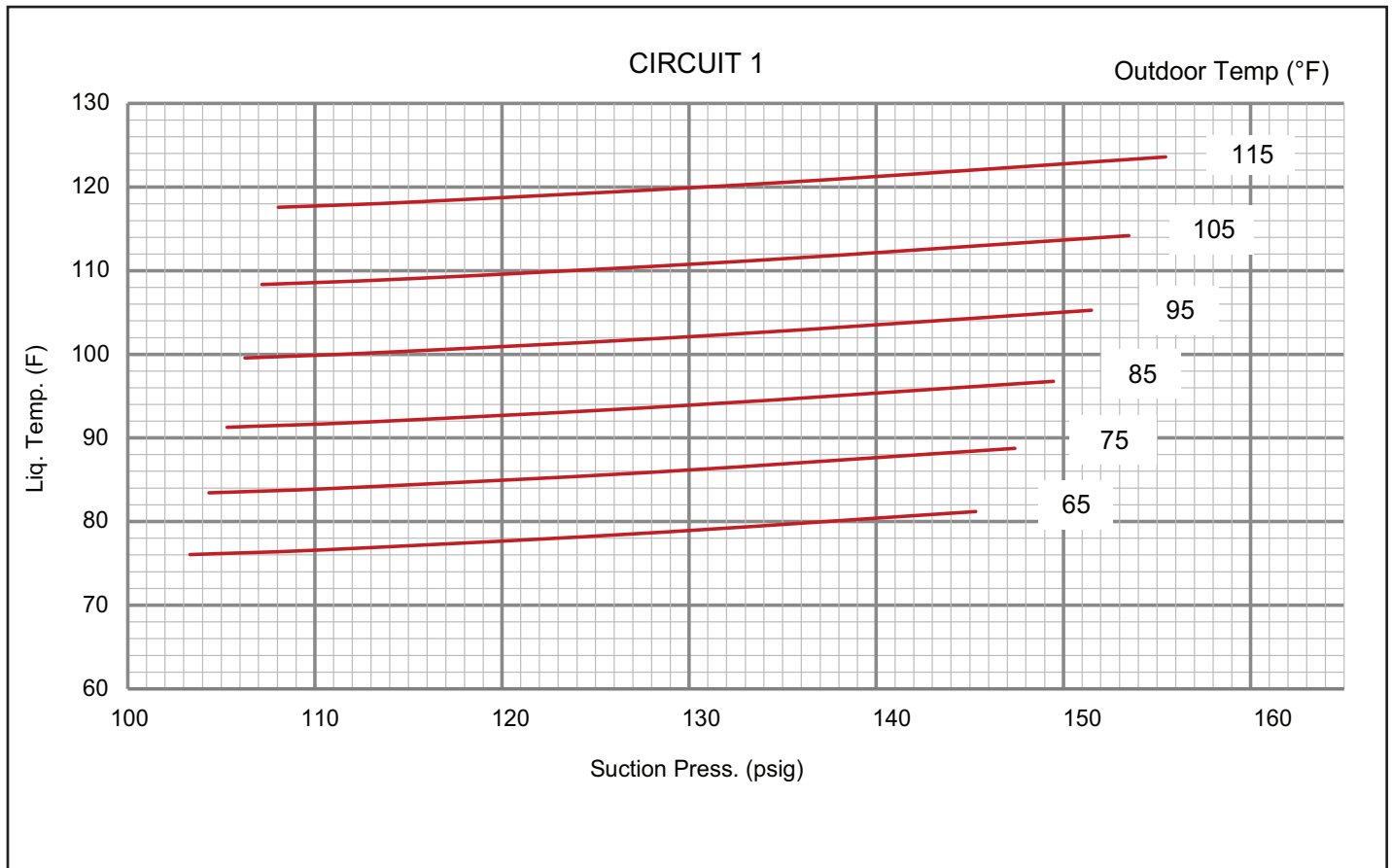

TABLE 10
LGX/LCX 210 NO REHEAT NORMAL OPERATING PRESSURES - ALL-ALUMINUM COIL - 581139-02

Outdoor Coil Entering Air Temperature												
	65°F		75°F		85°F		95°F		105°F		115°F	
	Suct (psig)	Disc (psig)	Suct (psig)	Disc (psig)	Suct (psig)	Disc (psig)	Suct (psig)	Disc (psig)	Suct (psig)	Disc (psig)	Suct (psig)	Disc (psig)
Circuit 1	103	239	104	277	105	321	106	371	107	427	108	489
	110	243	112	280	113	324	114	373	115	429	116	491
	127	250	128	287	130	330	131	379	133	434	135	495
	145	258	147	294	149	336	151	385	153	439	155	500
Circuit 2	102	246	104	285	107	329	109	379	111	433	113	493
	110	250	113	289	115	333	117	383	119	437	121	496
	128	260	131	298	133	342	135	391	137	445	139	504
	148	270	150	309	153	352	155	401	157	454	159	513
Circuit 3	105	254	107	294	110	340	112	392	114	449	115	513
	113	259	116	299	118	344	120	396	122	453	124	515
	130	270	133	309	136	353	138	404	140	460	142	522
	150	282	153	320	155	364	158	413	160	468	162	529

210 CHARGING CURVE CIRCUIT 1 - ALL-ALUMINUM COIL - 581138-02



210 CHARGING CURVE CIRCUIT 2 - ALL-ALUMINUM COIL - 581138-02

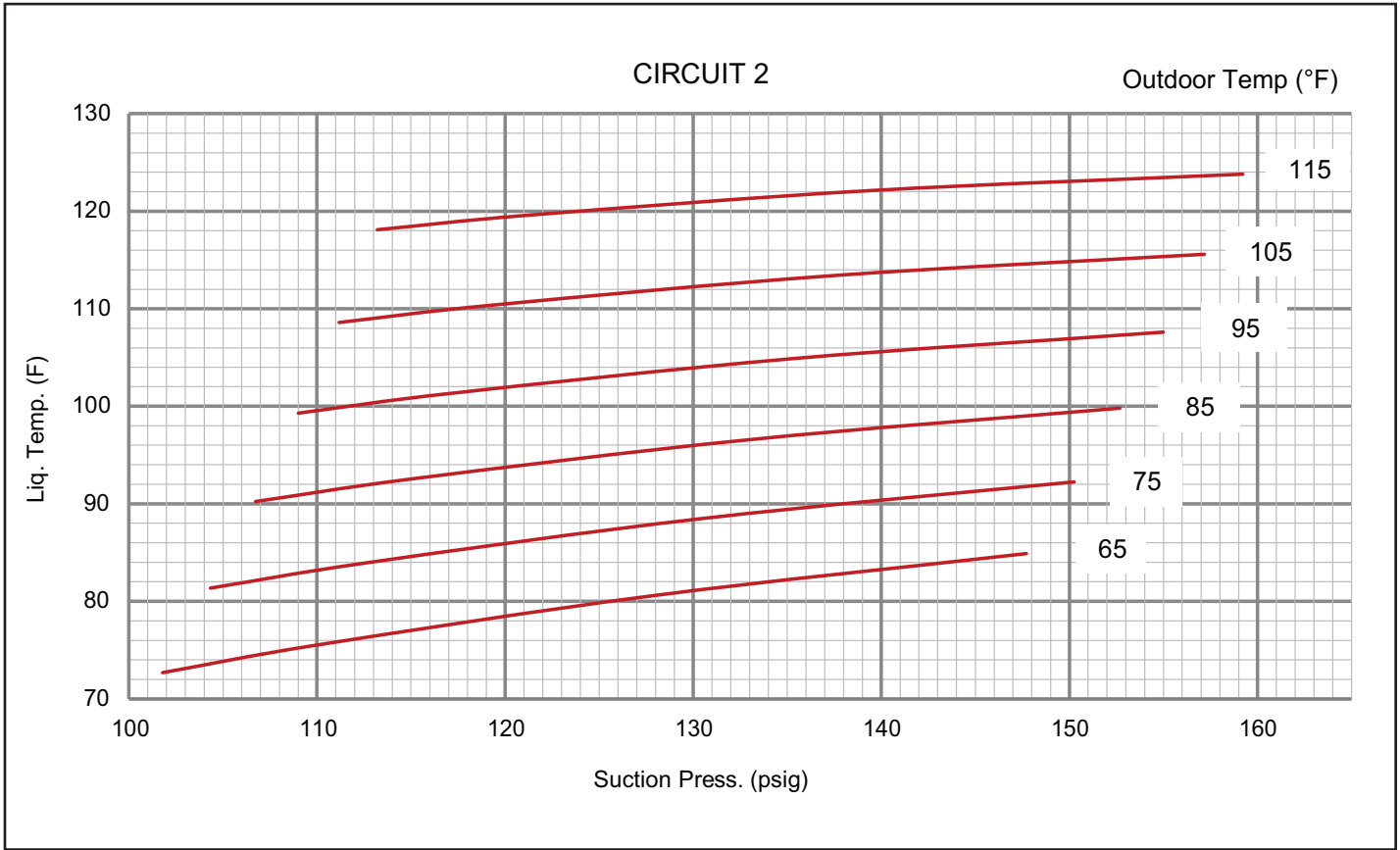

210 CHARGING CURVE CIRCUIT 3 - ALL-ALUMINUM COIL - 581138-02

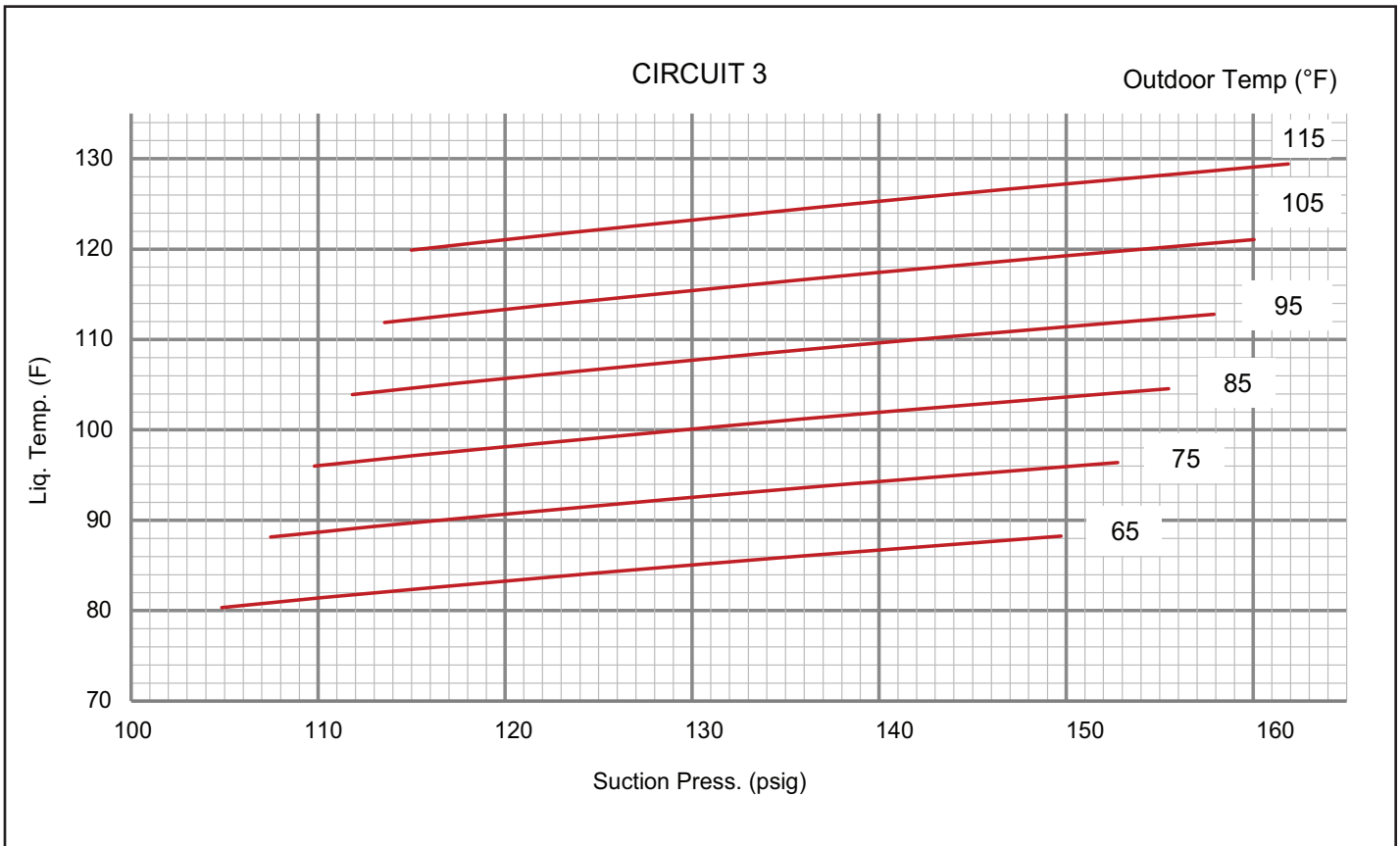
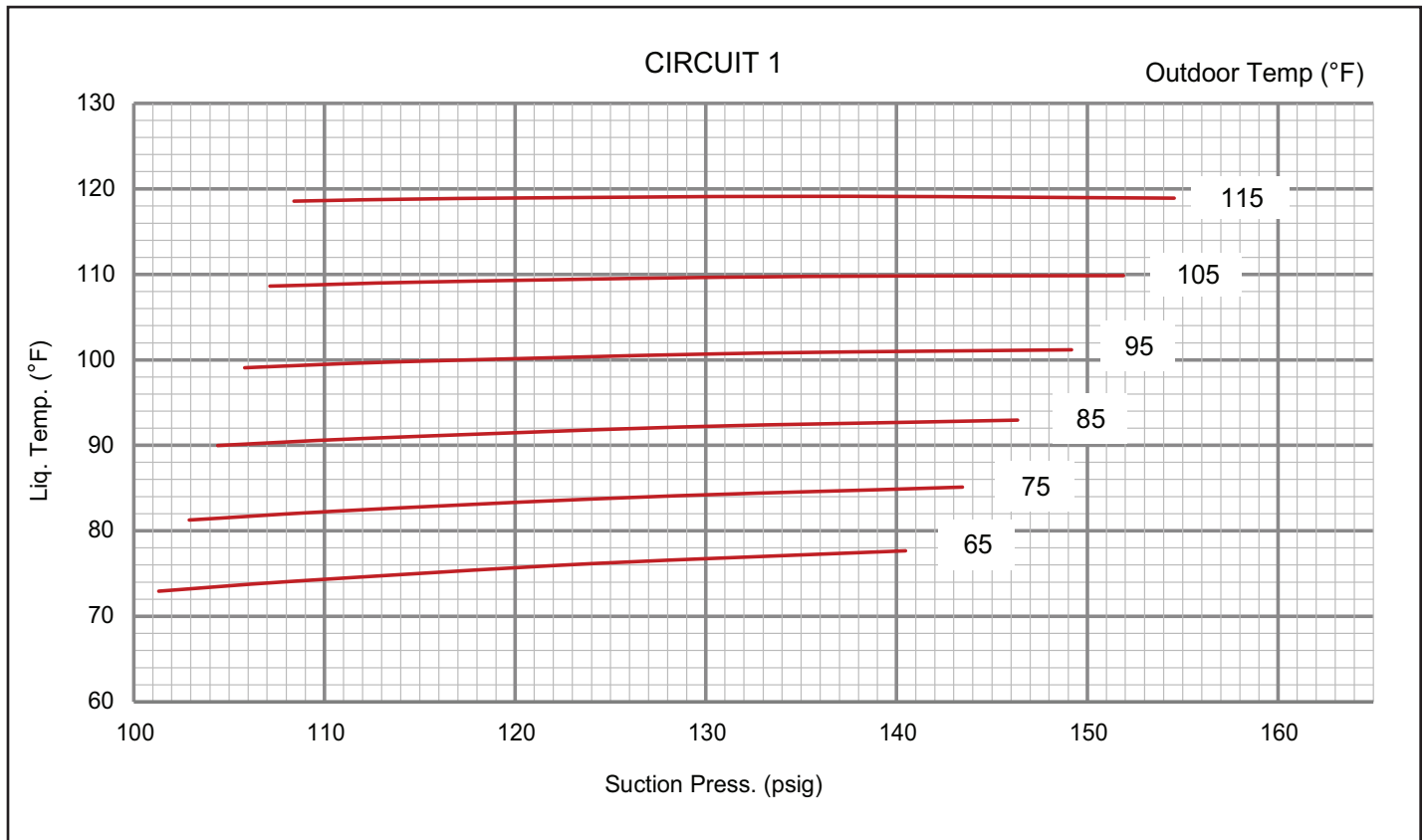

TABLE 11
LGX/LCX 240 NO REHEAT NORMAL OPERATING PRESSURES - ALL-ALUMINUM COIL - 581141-02

Outdoor Coil Entering Air Temperature												
	65°F		75°F		85°F		95°F		105°F		115°F	
	Suct (psig)	Disc (psig)	Suct (psig)	Disc (psig)	Suct (psig)	Disc (psig)	Suct (psig)	Disc (psig)	Suct (psig)	Disc (psig)	Suct (psig)	Disc (psig)
Circuit 1	101	233	103	271	104	315	106	362	107	415	108	471
	109	234	110	272	112	315	114	362	116	414	117	471
	124	238	126	276	129	318	131	365	133	416	135	472
	140	246	143	283	146	324	149	371	152	421	155	476
Circuit 2	104	240	105	281	106	326	106	375	107	426	108	481
	111	242	112	283	114	328	115	375	116	427	117	481
	127	248	129	289	131	332	133	380	135	430	137	484
	144	257	147	297	150	340	153	387	156	436	159	489
Circuit 3	99	247	101	285	104	328	106	374	108	424	109	478
	106	250	109	288	111	331	114	377	116	427	118	481
	121	257	124	296	128	338	130	384	133	434	135	488
	137	266	141	305	144	347	147	393	151	443	153	497

240 CHARGING CURVE CIRCUIT 1 - NO REHEAT - ALL-ALUMINUM COIL - 581140-02



240 CHARGING CURVE CIRCUIT 2 - NO REHEAT - ALL-ALUMINUM COIL - 581140-02

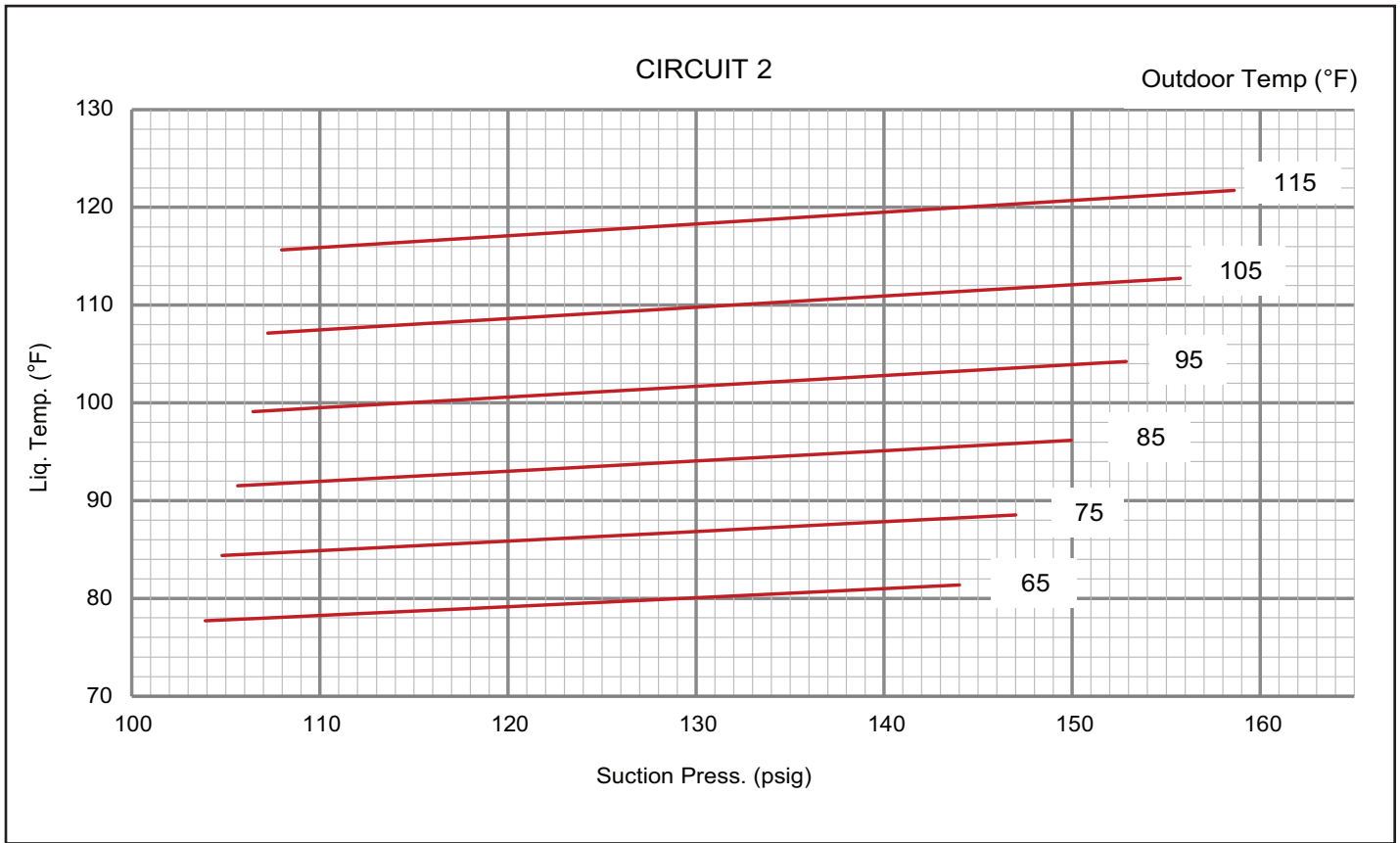

240 CHARGING CURVE CIRCUIT 3 - NO REHEAT - ALL-ALUMINUM COIL - 581140-02

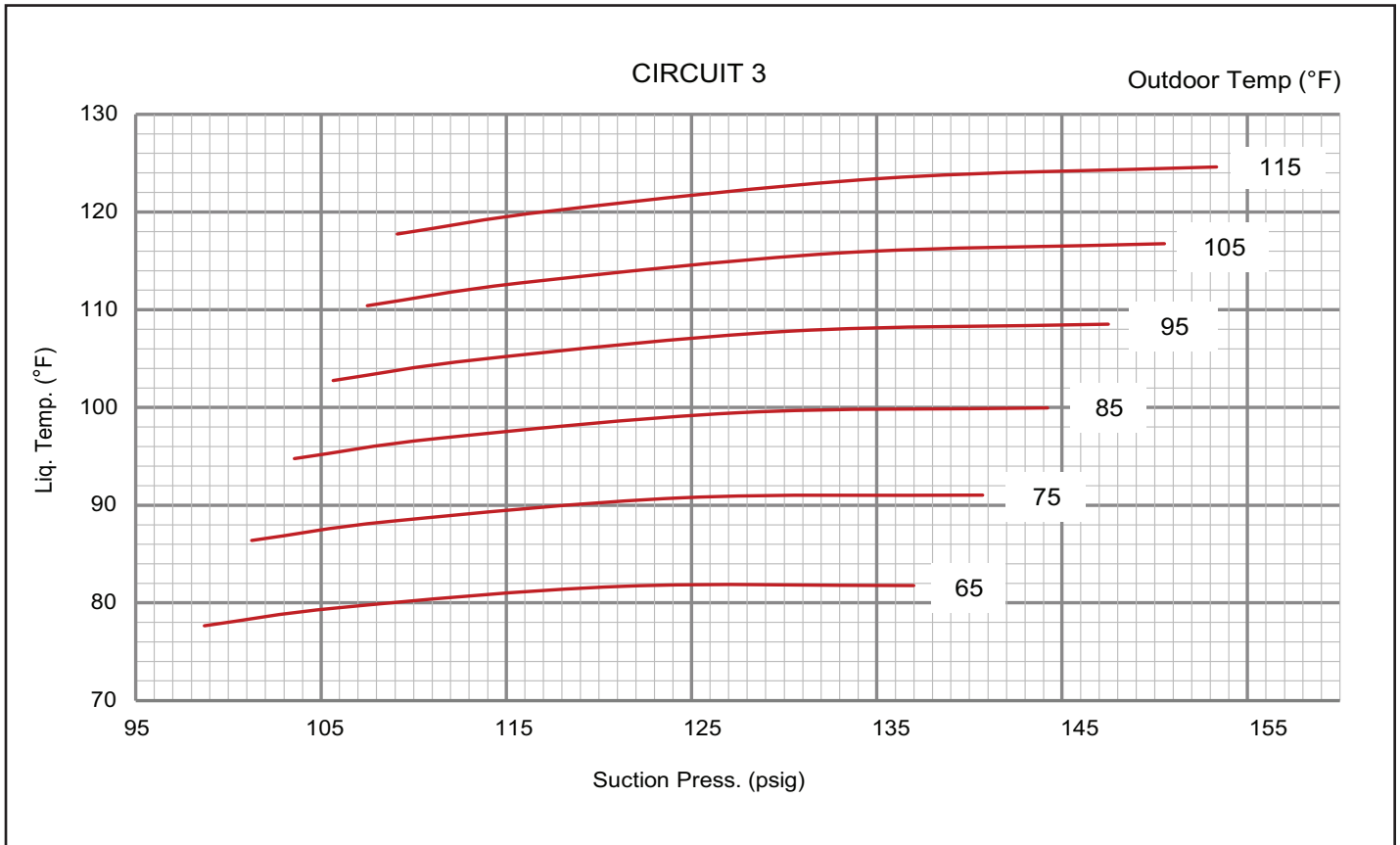
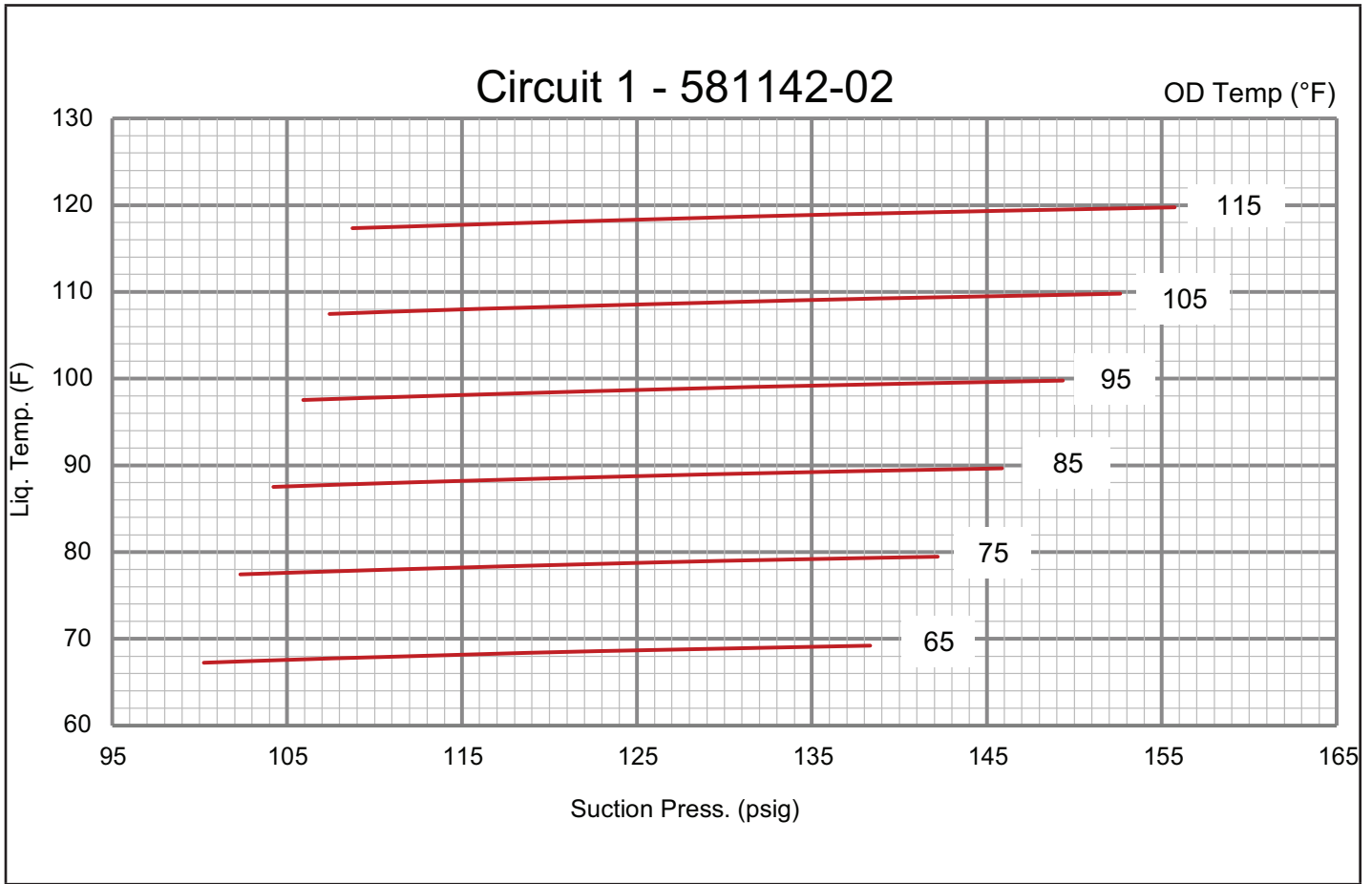
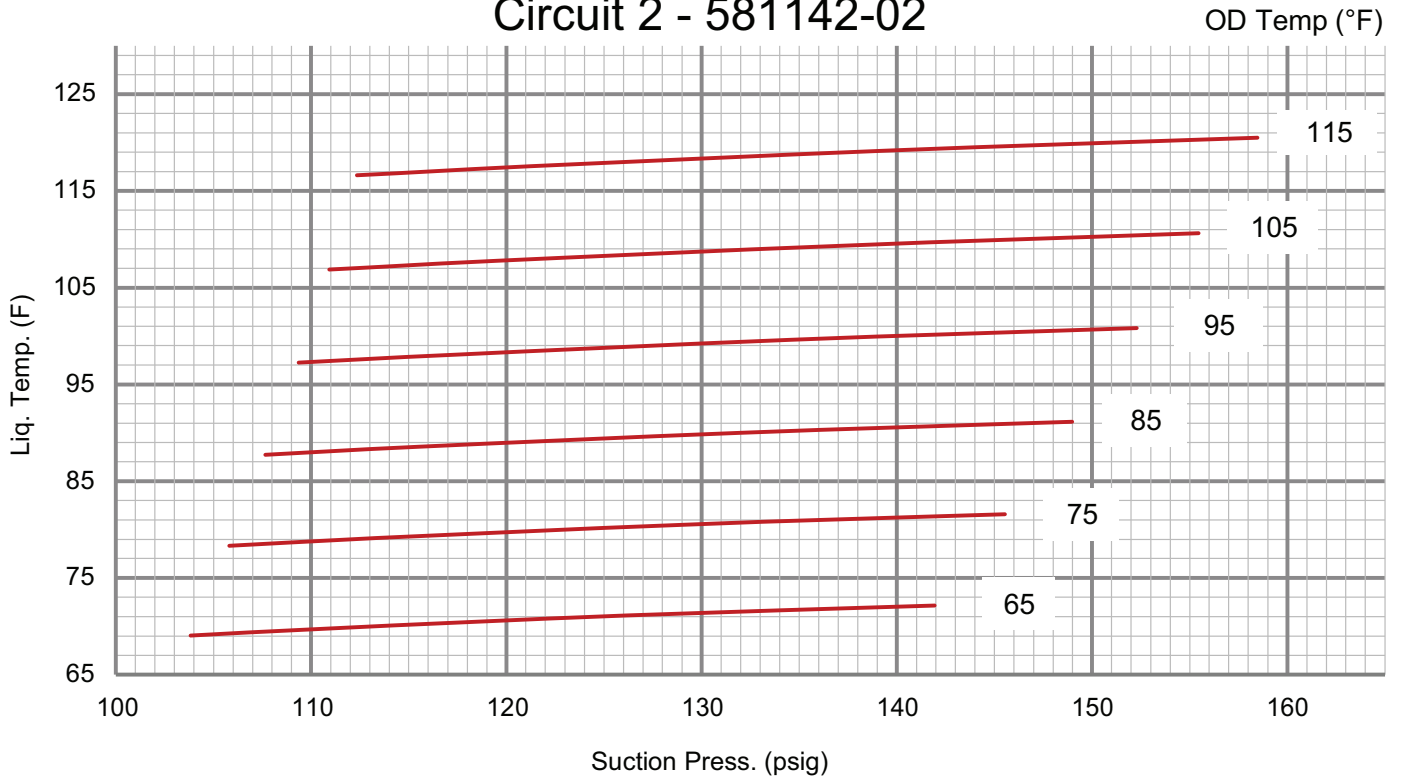

TABLE 12

LGX/LCX 300S NO REHEAT NORMAL OPERATING PRESSURES ALL - ALUMINUM COIL - 581143-02												
	Outdoor Coil Entering Air Temperature											
	65°F		75°F		85°F		95°F		105°F		115°F	
	Suct (psig)	Disc (psig)	Suct (psig)	Disc (psig)	Suct (psig)	Disc (psig)	Suct (psig)	Disc (psig)	Suct (psig)	Disc (psig)	Suct (psig)	Disc (psig)
Circuit 1	100	233	102	269	104	311	106	358	107	410	109	467
	108	236	110	272	112	314	114	361	116	412	118	469
	123	242	126	278	129	319	132	366	134	417	137	474
	138	248	142	284	146	325	149	371	153	422	156	479
Circuit 2	104	238	106	276	108	319	109	367	111	420	112	477
	111	241	113	280	116	323	118	371	119	423	121	481
	126	249	129	287	132	330	135	378	137	431	139	488
	142	256	146	295	149	338	152	385	155	438	158	495
Circuit 3	80	234	82	272	84	315	86	363	88	417	90	476
	87	236	89	273	91	316	93	364	95	418	97	477
	102	242	104	279	106	321	109	369	111	422	113	481
	120	251	122	288	124	330	127	377	129	430	131	488
Circuit 4	87	234	89	272	91	315	92	361	94	412	95	467
	93	238	96	276	98	319	100	365	102	416	103	471
	106	246	109	285	112	327	115	374	118	425	121	480
	120	255	124	294	128	336	132	383	136	434	139	489



Circuit 2 - 581142-02



CIRCUIT 3

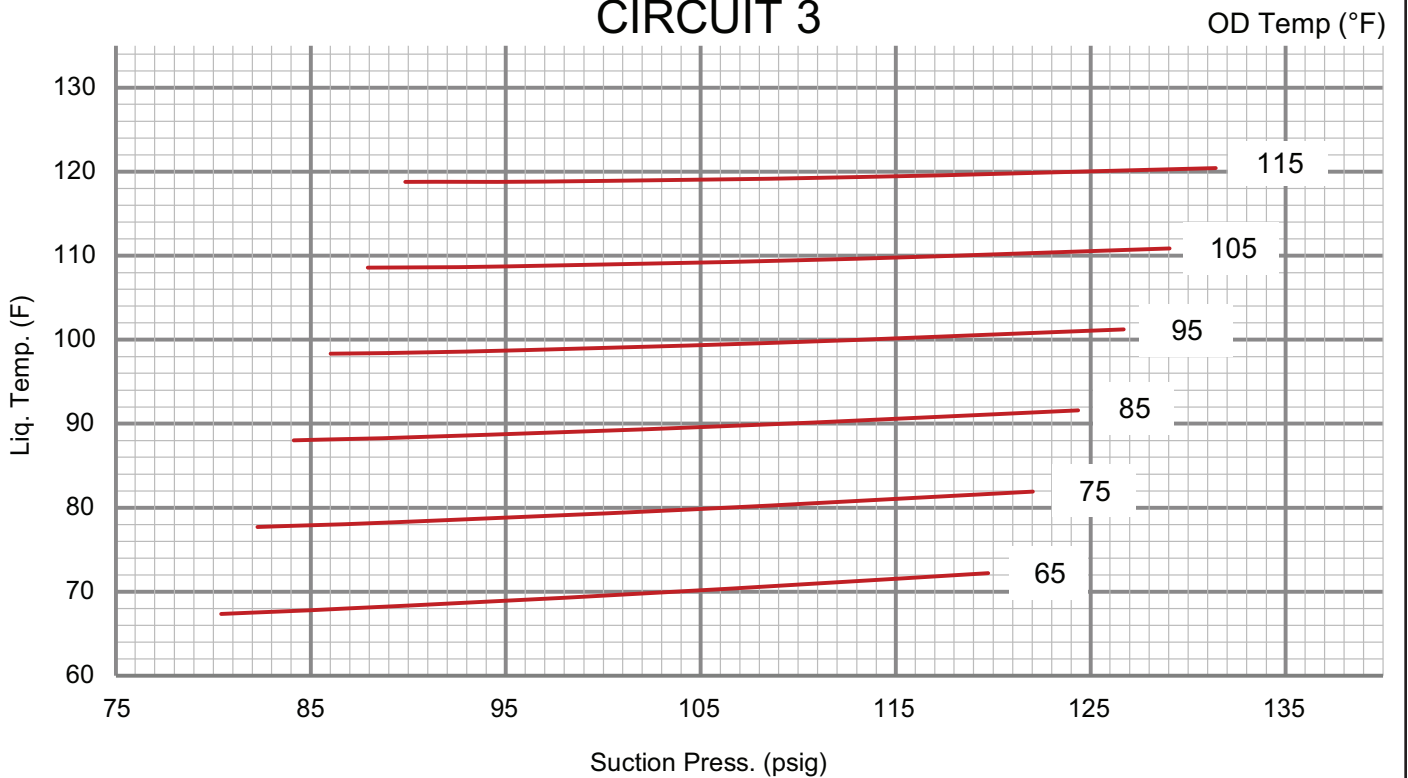

CIRCUIT 4

OD Temp (°F)

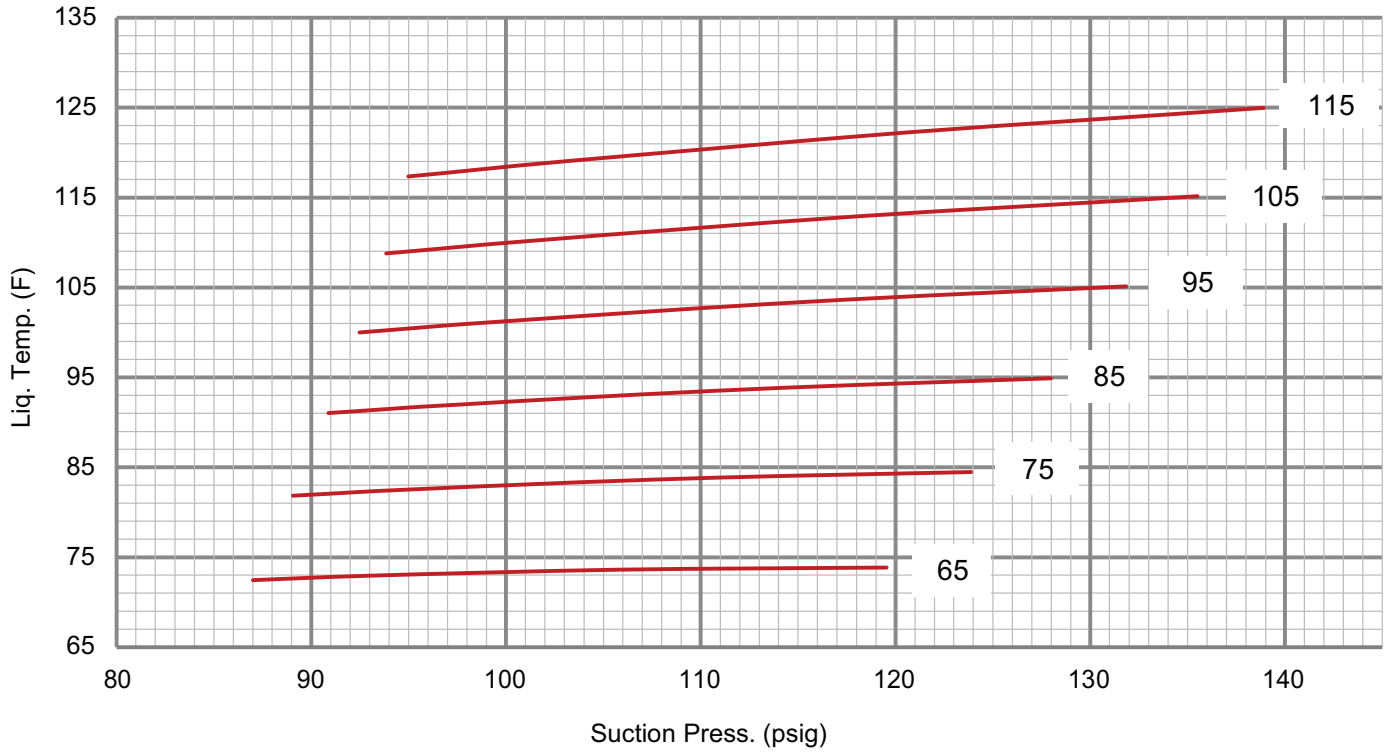

F-Compressor Controls

See unit wiring diagram to determine which controls are used on each unit. Optional controls are identified on wiring diagrams by arrows at junction points.

1 - High Pressure Switches (S4, S7, S28, S96)

Switches open to de-energize appropriate compressor at 640 psig + 20 psig (4413kPa + 138kPa). Switch automatically resets once pressure falls below 475 psig +/- 20 psig.

2 - Low Pressure Switches (S87, S88, S97, S98)

Switches open to de-energize appropriate compressor at 40 psig +/- 5 psig. Switch automatically resets when pressures rise above 90 psig +/- 5 psig.

3 - Crankcase Heater (HR1, HR2, HR5, HR11)

Units have compressors which contain a belly band compressor oil heater which must be on 24 hours before running compressors. Energize by setting thermostat so that there is no cooling demand, to prevent compressor from cycling, and apply power to unit.

Prognostic Sensors

Temperature thermistor sensors are located on specific points for each refrigeration circuit. Temperature thermistors provide continuous temperature input to the unit controller for proper cooling operation as well as system protection. Controller logic will de-energize compressors for each refrigeration circuit when evaporator coil temperature falls below 32°F (0°C) to prevent evaporator freeze-up.

Each thermistor must be specifically placed for proper unit operation and to initiate valid alarms. See TABLE 13 through TABLE 14 for proper locations.

TABLE 13
LGX/LCX180, 210, 240

Cat. No.	Ass'y. No.	Sensor Yellow, Blue, Red	Figure
22J06	623049-01	RT46, 47, 50	FIGURE 23

TABLE 14
LGX/LCX300

Cat. No.	Ass'y. No.	Sensor Yel, Blu, Red, Grn	Figure
22J06	623049-01	RT46, 47, 50, 51	FIGURE 24

LGX/LCX180, 210, 240
EVAPORATOR / INDOOR COIL
RT46, 47, 50

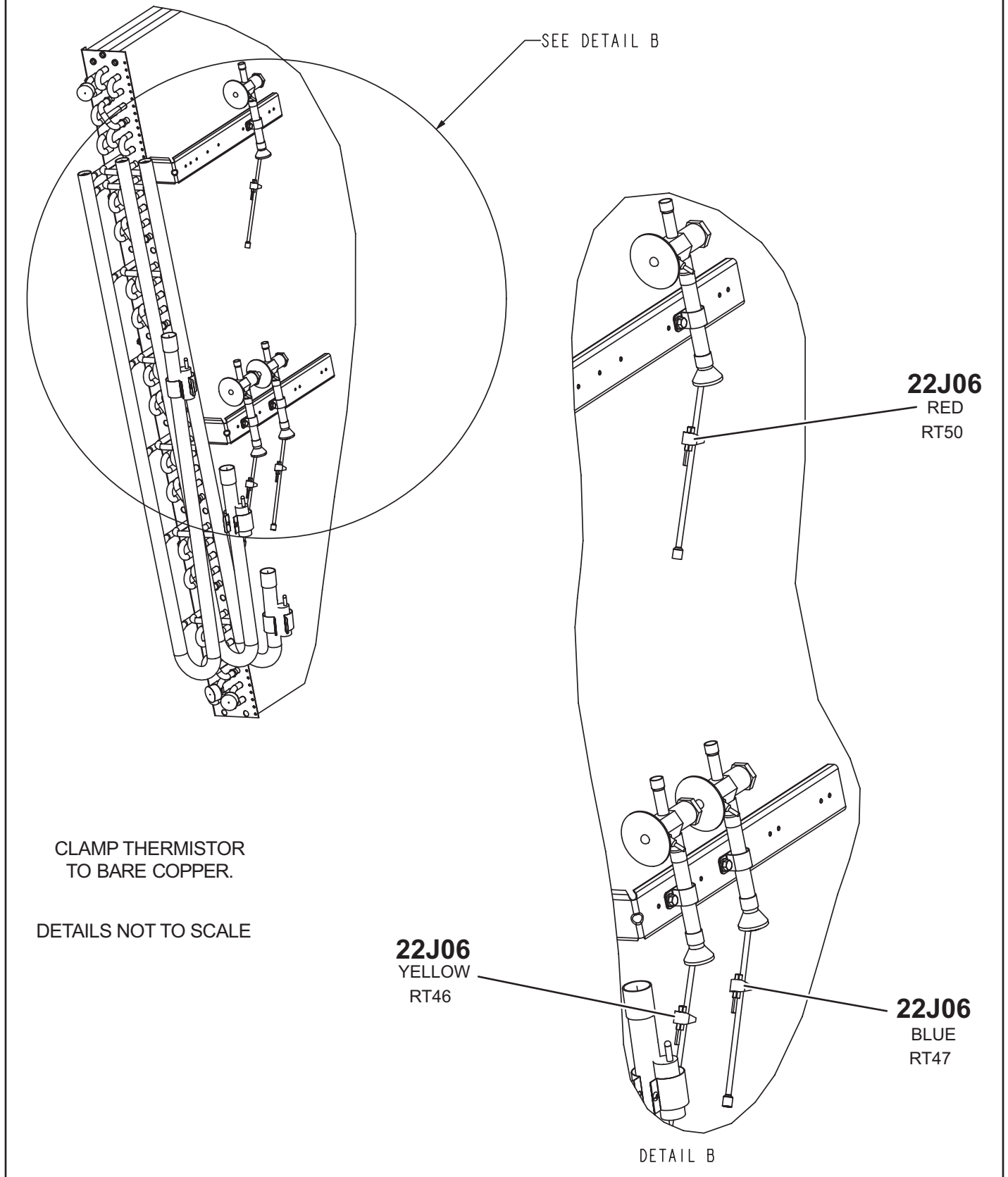
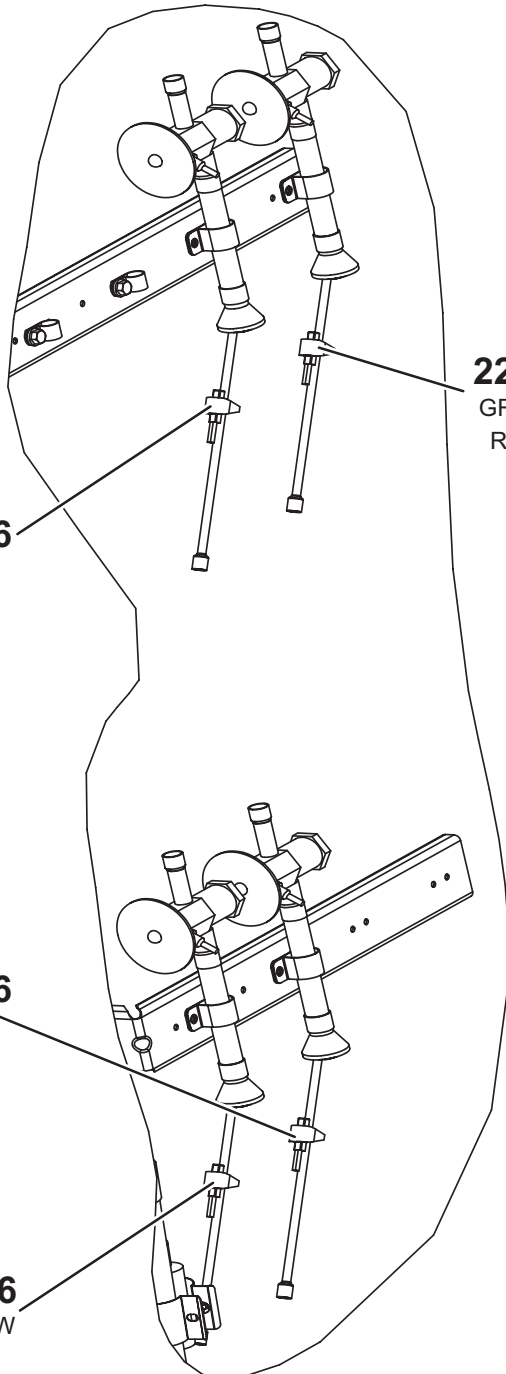
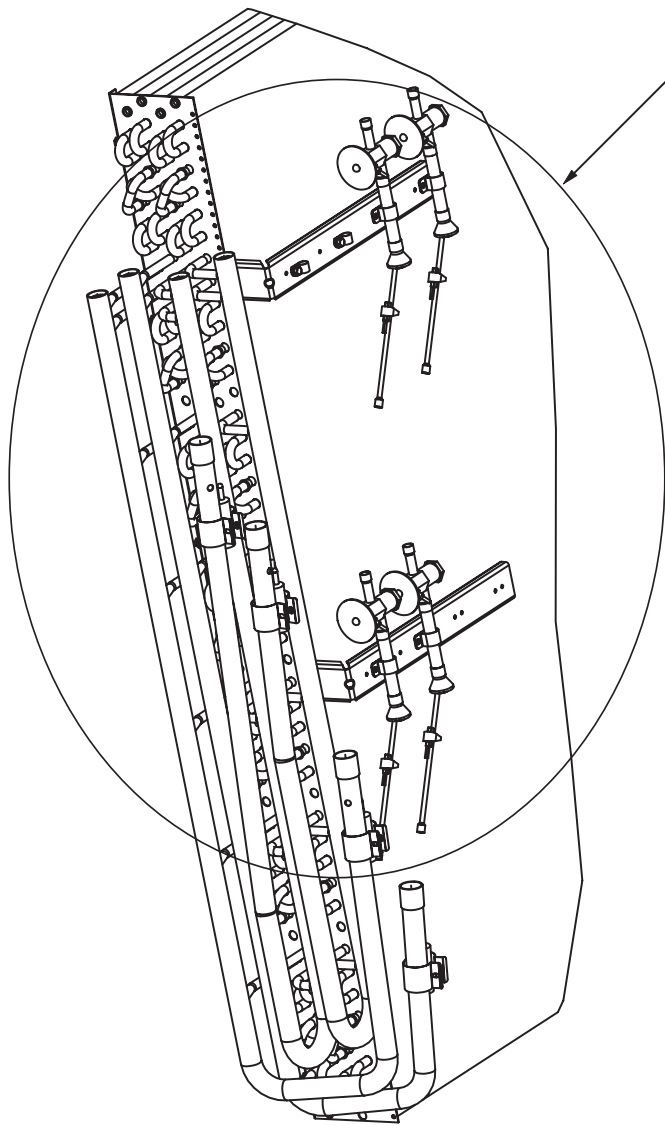

FIGURE 23

LGX/LCX300
EVAPORATOR / INDOOR COIL
RT46, 47, 50, 51

SEE DETAIL C



22J06
GREEN
RT51

CLAMP THERMISTOR
TO BARE COPPER.

DETAILS NOT TO SCALE

DETAIL C

FIGURE 24

RDS Sensors

Units are equipped with factory-installed RDS Sensors located on different points on the unit. The RDS sensors provide the Unit Controller with continuous readings for leaked refrigerant concentration levels and sensor health status (Good or Fault). These readings are used to modify unit operation to disperse the leaked refrigerant and to remove possible ignition sources. In addition, the Unit Controller uses these readings to initiate alarms to alert the operator of a refrigerant leak or faulty sensor(s).

Each sensor must be specifically placed for proper unit operation and to initiate valid alarms. To identify sensor locations see TABLE 15.

TABLE 15
RDS Sensor Figures

Model	Qty.	Type	Figure
LCX/LGX 180-300	2 sensors	INDOOR SENSOR	FIGURE 25
		COMPRESSOR SENSOR	FIGURE 26

LCX/LGX 180-300
INDOOR COMPARTMENT RDS SENSOR

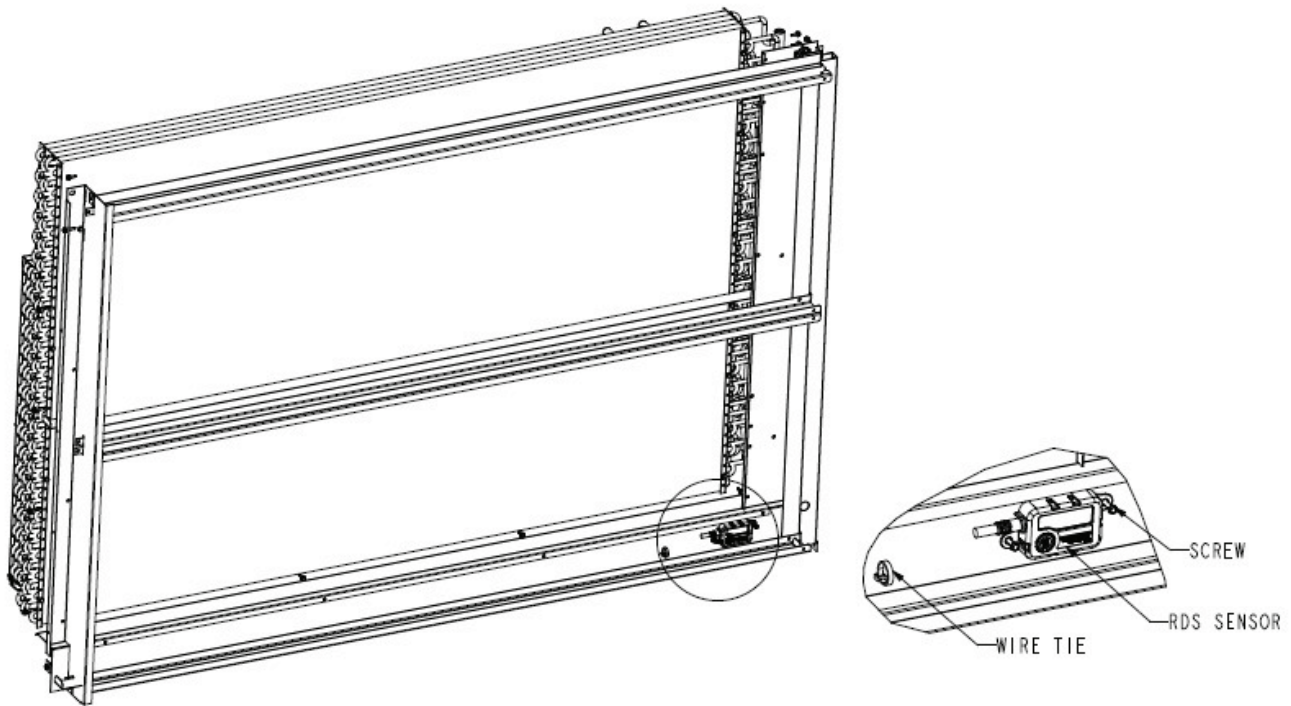

FIGURE 25

LCX/LGX 180-300
COMPRESSOR RDS SENSOR

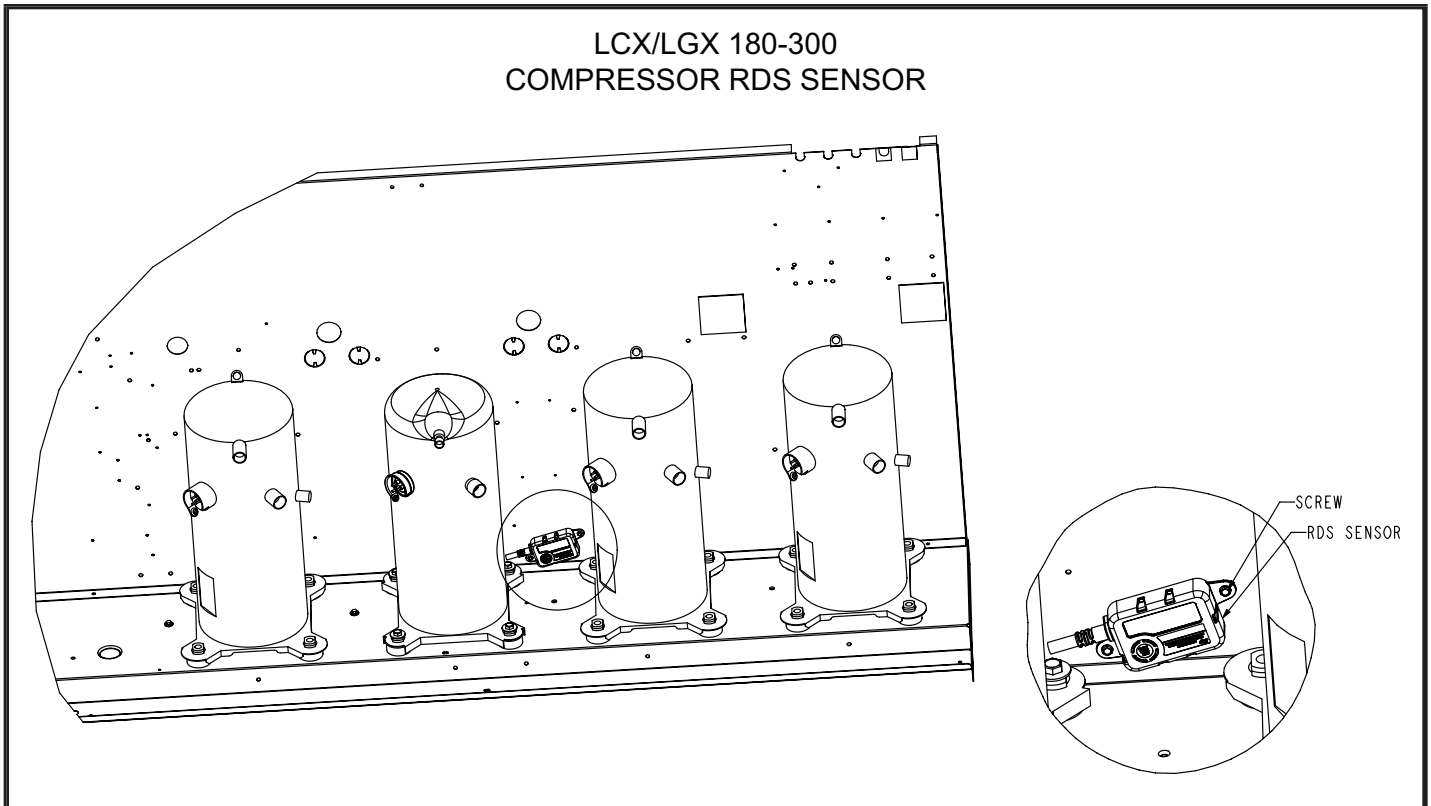

FIGURE 26

Gas Heat Start-Up (Gas Units)

FOR YOUR SAFETY READ BEFORE LIGHTING

BEFORE LIGHTING smell all around the appliance area for gas. Be sure to smell next to the floor because some gas is heavier than air and will settle on the floor.

Use only your hand to push in or turn the gas control knob. Never use tools. If the knob will not push in or turn by hand, do not try to repair it, call a qualified service technician. Force or attempted repair may result in a fire or explosion.

This unit is equipped with an automatic spark ignition system.

There is no pilot. In case of a safety shutdown, move thermostat switch to **OFF** and return the thermostat switch to **HEAT** to reset ignition control.

⚠ WARNING	
	Electric shock hazard. Can cause injury or death. Do not use this unit if any part has been under water. Immediately call a qualified service technician to inspect the unit and to replace any part of the control system and any gas control which has been under water.

⚠ WARNING	
	Danger of explosion. Can cause injury or product or property damage. If overheating occurs or if gas supply fails to shut off, shut off the manual gas valve to the appliance before shutting off electrical supply.

⚠ WARNING	
	Electric shock hazard. Can cause injury or death. Before attempting to perform any service or maintenance, turn the electrical power to unit OFF at disconnect switch(es). Unit may have multiple power supplies.

⚠ WARNING	
SMOKE POTENTIAL	
The heat exchanger in this unit could be a source of smoke on initial firing. Take precautions with respect to building occupants and property. Vent initial supply air outside when possible.	

⚠ WARNING	
	Danger of explosion. Can cause injury or death. Do not attempt to light manually. Unit has a direct spark ignition system.

A-Placing Unit in Operation

⚠ WARNING



Danger of explosion and fire. Can cause injury or product or property damage. You must follow these instructions exactly.

Gas Valve Operation for Honeywell VR8205Q / VR8305Q and White Rodgers 36H54 (FIGURE 27)

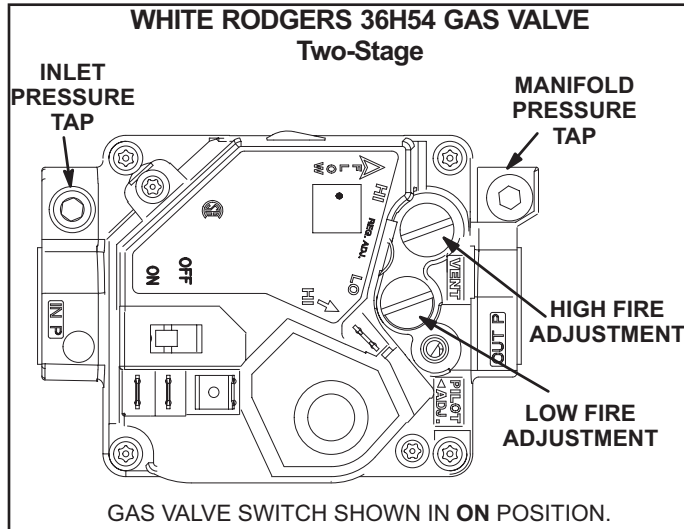

FIGURE 27

- 1 - Set thermostat to lowest setting.
- 2 - Turn off all electrical power to appliance.
- 3 - This appliance is equipped with an ignition device which automatically lights the burner. Do **not** try to light the burner by hand.
- 4 - Open or remove the heat section access panel.
- 5 - Turn gas valve switch to **OFF**. See FIGURE 27.
- 6 - Wait five (5) minutes to clear out any gas. If you then smell gas, **STOP!** Immediately call your gas supplier from a neighbor's phone. Follow the gas supplier's instructions. If you do not smell gas, go to the next step.
- 7 - Turn gas valve switch to **ON**. See FIGURE 27.
- 8 - Close or replace the heat section access panel.
- 9 - Turn on all electrical power to appliance.
- 10 - Set thermostat to desired setting.
- 11 - The ignition sequence will start.
- 12 - If the appliance does not light the first time (gas line not fully purged), it will attempt up to two more ignitions before locking out.
- 13 - If lockout occurs, repeat steps 1 through 10.
- 14 - If the appliance will not operate, follow the instructions "Turning Off Gas to Unit" and call your service technician or gas supplier.

Turning Off Gas to Unit

- 1 - If using an electromechanical thermostat, set to the lowest setting.
- 2 - Before performing any service, turn off all electrical power to the appliance.
- 3 - Open or remove the heat section access panel.
- 4 - Turn gas valve switch to **OFF**.
- 5 - Close or replace the heat section access panel.

⚠ WARNING



Danger of explosion. Can cause injury or death. Do not attempt to light manually. Unit has a direct spark ignition system.

Heating Operation and Adjustments

(Gas Units)

A-Heating Sequence of Operation

- 1 - On a heating demand the combustion air inducer starts immediately.
- 2 - Combustion air pressure switch proves inducer operation. After a 30-second pre-purge, power is allowed to ignition control. Switch is factory set and requires no adjustment.
- 3 - Spark ignitor energizes and gas valve solenoid opens.
- 4 - Spark ignites gas, ignition sensor proves the flame and combustion continues.
- 5 - If flame is not detected after first ignition trial, ignition control will repeat steps 3 and 4 two more times before locking out the gas valve.
- 6 - For troubleshooting purposes, an ignition attempt after lock out may be re-established manually. Move thermostat to **OFF** and return thermostat switch to **HEAT** position.

B-Limit Controls

Limit controls are factory-set and are not adjustable. Two limits are located on the drip shield in the blower compartment. See FIGURE 28.

C-Heating Adjustment

Main burners are factory-set and do not require adjustment. The following manifold pressures are listed on the gas valve.

Natural Gas Units - Low Fire - 1.6" w.c. (not adjustable)

Natural Gas Units - High Fire - 3.7" w.c.

LP Gas Units - Low Fire - 5.5" w.c. (not adjustable)

LP Gas Units - High Fire - 10.5" w.c.

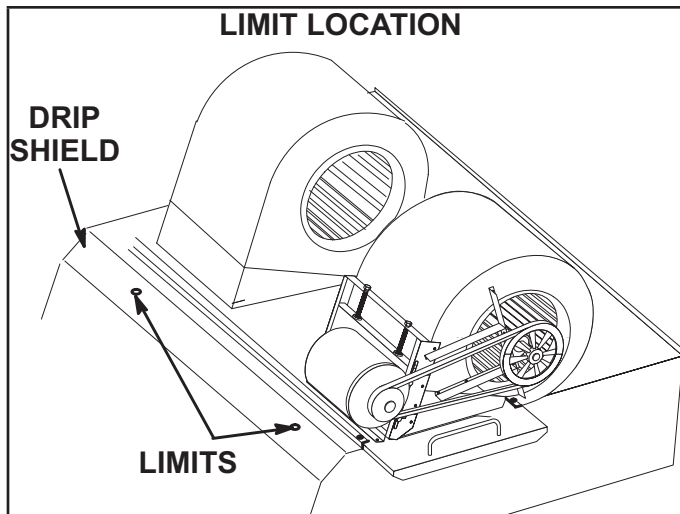

FIGURE 28

Electric Heat Start-Up (LCX Units)

Field-Installed Option

Electric heat will stage on and cycle with thermostat demand. Number of stages of electric heat will vary depending on electric heat assembly. See electric heat wiring diagram on unit for sequence of operation.

SEQUENCE OF OPERATION

MULTI-STAGE AIR VOLUME

180/210/240/300 MODELS (3 AND 4 COMPRESSORS)

UNIT OPERATION WITH 2-STAGE THERMOSTAT (2 COOLING STAGES, Y1, Y2)

SUPPLY AIR BLOWER SPEED

Unit has following supply air blower speed setting:

- Ventilation speed
- Cooling Speed - Low
- Cooling Speed - High
- Heating Speed
- Smoke Speed (Using only in smoke removal option - not discussed)

¹ Unit Features and Economizer and Outdoor Air is Suitable

Y1 Demand:

All compressors are off, supply air blower is on low cooling speed to minimize blower power consumption, economizer modulates (minimum to maximum open position) to maintain 55°F supply air temperature (default unit controller setting).

Y2 Demand:

All compressors are off, supply air blower is on high cooling speed providing higher cooling capacity, and economizer modulates to maintain 55°F supply air temperature. If economizer stays at maximum open for 3 minutes, 1st stage compressors (compressor 1 and 2) are energized while supply air blower stays on high cooling speed providing maximum cooling capacity.

¹ Outdoor air suitability is determined by the energy state of outdoor ambient (enthalpy or sensible) and its ability to achieve the desired free cooling effects. Outdoor air suitability can also be determined by a third party controller and provided to the rooftop unit via a network connection.

Unit Does Not Feature An Economizer Or Outdoor Air Is Not Suitable

Y1 Demand:

1st stage compressors 1 & 2 operate and supply air blower operates at low cooling speed.

Y2 Demand:

All compressors operate and supply air blower operates at high cooling speed.

180/210/240/300 MODELS (3 AND 4 COMPRESSORS)**ZONE SENSOR****SUPPLY AIR BLOWER SPEED**

Unit has following supply air blower speed setting:

- Ventilation speed
- Cooling Speed - Low
- Cooling Speed - High
- Heating Speed
- Smoke Speed (Using only in smoke removal option - not discussed)

¹ Unit Features and Economizer and Outdoor Air is Suitable

3 Compressor Units**Y1 Demand:**

All compressors are off, supply air blower is on low cooling speed to minimize blower power consumption, economizer modulates (minimum to maximum open position) to maintain 55°F supply air temperature (default unit controller setting).

Y2 Demand:

All compressors are off, supply air blower is on high cooling speed providing higher cooling capacity, economizer modulates (minimum to maximum open position) to maintain 55°F supply air temperature (default unit controller setting).

If economizer stays at maximum open for 3 minutes then compressor 1 is energized while supply air blower stays on high cooling speed. After compressor is energized the economizer stays at maximum open.

Y3 Demand:

Compressors 1 and 2 are energized while supply air blower stays on high cooling speed. After compressors are energized the economizer stays at maximum.

Y4 Demand:

All compressors are energized and supply air blower stays on high cooling speed.

4 Compressor Units**Y1 Demand:**

All compressors are off, supply air blower is on low cooling speed to minimize blower power consumption, economizer modulates (minimum to maximum open position) to maintain 55°F supply air temperature (default unit controller setting).

Y2 Demand:

All compressors are off, supply air blower is on high cooling speed providing higher cooling capacity, economizer modulates (minimum to maximum open position) to maintain 55°F supply air temperature (default unit controller setting).

If economizer stays at maximum open for 3 minutes then compressors 1 and 2 are energized while supply air blower stays on high cooling speed. After compressors are energized the economizer stays at maximum open.

Y3 Demand:

Compressors 1, 2 and 3 are energized and supply air blower stays on high cooling speed.

Y4 Demand:

All compressors are energized and supply air blower stays on high cooling speed.

¹ Outdoor air suitability is determined by the energy state of outdoor ambient (enthalpy or sensible) and its ability to achieve the desired free cooling effects. Outdoor air suitability can also be determined by a third party controller and provided to the rooftop unit via a network connection.

180/210/240/300 MODELS (3 AND 4 COMPRESSORS) (CONTINUED)**ZONE SENSOR**

Unit **Does Not** Feature An Economizer Or Outdoor Air Is Not Suitable

3 Compressor Units**Y1 Demand:**

Compressor 1 operates and supply air blower operates at low cooling speed.

Y2 Demand:

Compressors 1 and 2 operate and supply air blower operates at low cooling speed.

Y3 Demand:

Compressors 1, 2, and 3 operate and supply air blower operates at high cooling speed .

4 Compressor Units**Y1 Demand:**

Compressor 1 operates and supply air blower operates at low cooling speed.

Y2 Demand:

Compressors 1 and 2 operate and supply air blower operates at low cooling speed.

Y3 Demand:

Compressors 1, 2, and 3 operate and supply air blower operates at high cooling speed.

Y4 Demand:

All compressors operate and supply air blower operates at high cooling speed.

Preventative Maintenance / Repair

IMPORTANT MAINTENANCE / REPAIR SAFETY INSTRUCTIONS

Prior to beginning work on systems containing FLAMMABLE REFRIGERANTS, safety checks are necessary to ensure that the risk of ignition is minimized.

Work shall be undertaken under a controlled procedure to minimize the risk of a flammable gas or vapor being present while the work is being performed.

All maintenance staff and others working in the local area shall be instructed on the nature of work being carried out. Work in confined spaces shall be avoided.

The area shall be checked with an appropriate refrigerant detector prior to and during work, to ensure the technician is aware of potentially toxic or flammable atmospheres. Ensure that the leak detection equipment being used is suitable for use with all applicable refrigerants, i.e. non-sparking, adequately sealed or intrinsically safe.

If any hot work is to be conducted on the refrigerating equipment or any associated parts, appropriate fire extinguishing equipment shall be available to hand. Have a dry powder or CO₂ fire extinguisher adjacent to the charging area.

No person carrying out work in relation to a REFRIGERATING SYSTEM which involves exposing any pipe work shall use any sources of ignition in such a manner that it may lead to the risk of fire or explosion. All possible ignition sources, including cigarette smoking, should be kept sufficiently far away from the site of installation, repairing, removing and disposal, during which refrigerant can possibly be released to the surrounding space. Prior to work taking place, the area around the equipment is to be surveyed to make sure that there are no flammable hazards or ignition risks. "No Smoking" signs shall be displayed.

Where electrical components are being changed, they shall be fit for the purpose and to the correct specification. At all times, the manufacturer's maintenance and service guidelines shall be followed. If in doubt, consult the manufacturer's technical department for assistance.

Repair and maintenance to electrical components shall include initial safety checks and component inspection procedures. If a fault exists that could compromise safety, then no electrical supply shall be connected to the circuit until it is satisfactorily dealt with. If the fault cannot be corrected immediately but it is necessary to continue operation, an adequate temporary solution shall be used. This shall be reported to the owner of the equipment so all parties are advised.

Initial safety checks shall include:

- that capacitors are discharged: this shall be done in a safe manner to avoid possibility of sparking
- that no live electrical components and wiring are exposed while charging, recovering or purging the system
- that there is continuity of earth bonding

The following checks shall be applied to installations using FLAMMABLE REFRIGERANTS:

- the actual REFRIGERANT CHARGE is in accordance with the room size within which the refrigerant containing parts are installed;
- the ventilation machinery and outlets are operating adequately and are not obstructed;
- if an indirect refrigerating circuit is being used, the secondary circuit shall be checked for the presence of refrigerant;
- marking to the equipment continues to be visible and legible. Markings and signs that are illegible shall be corrected;
- refrigerating pipe or components are installed in a position where they are unlikely to be exposed to any substance which may corrode refrigerant containing components, unless the components are constructed of materials which are inherently resistant to being corroded or are suitably protected against being so corroded.

During repairs to sealed electrical components, the components shall be replaced. Replacement parts shall be in accordance with the manufacturer's specifications.

During repairs to intrinsically safe components, the components must be replaced. Replace components only with parts specified by the manufacturer. Other parts may result in the ignition of refrigerant in the atmosphere from a leak.

The unit should be inspected once a year by a qualified service technician.

A-Filters

Units are equipped with six 24 X 24 X 2" filters. Filters should be checked monthly and replaced when necessary with filters of like kind and size. Take note of air flow direction marking on filter frame when reinstalling filters. See FIGURE 29.

NOTE - Filters must be U.L.C. certified or equivalent for use in Canada.

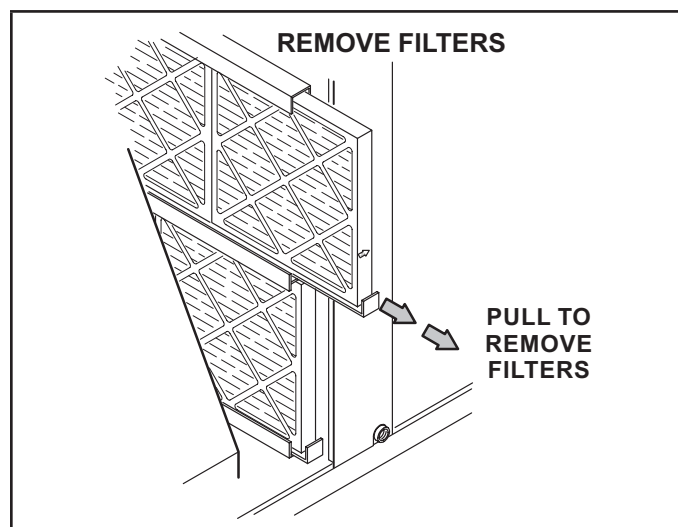

FIGURE 29

⚠ CAUTION

Label all wires prior to disconnection when servicing controls. Wiring errors can cause improper and dangerous operation. Verify proper operation after servicing.

B-Lubrication

All motors are lubricated at the factory. No further lubrication is required.

Blower shaft bearings are prelubricated. For extended bearing life, relubricate at least once every two years with a lithium base grease, such as Alvania 3 (Shell Oil), Chevron BRB2 (Standard Oil) or Regal AFB2 (Texas Oil). Use a hand grease gun for relubrication. Add only enough grease to purge through the bearings so that a bead of grease appears at the seal lip contacts.

C-Burners (Gas Units)

Periodically examine burner flames for proper appearance during the heating season. Before each heating season examine the burners for any deposits or blockage which may have occurred.

Clean burners as follows:

- 1 - Turn off both electrical power and gas supply to unit.
- 2 - Open burner compartment access panel.
- 3 - Remove screws securing burner assembly to burner support and remove assembly. See FIGURE 30. Clean as necessary.
- 4 - Locate the ignitor under the left burners. Check ignitor spark gap with appropriately sized twist drills or feeler gauges. See FIGURE 31.
- 5 - Check the alignment of the ignitor and the sensor as shown in FIGURE 32 and TABLE 16.
- 6 - Replace burners and screws securing burner.
- 7 - Replace access panel.
- 8 - Restore electrical power and gas supply. Follow lighting instructions attached to unit and use inspection port in access panel to check flame.

⚠ WARNING



Danger of explosion. Can cause injury or death. Do not overtighten main burner mounting screws. Snug tighten only.

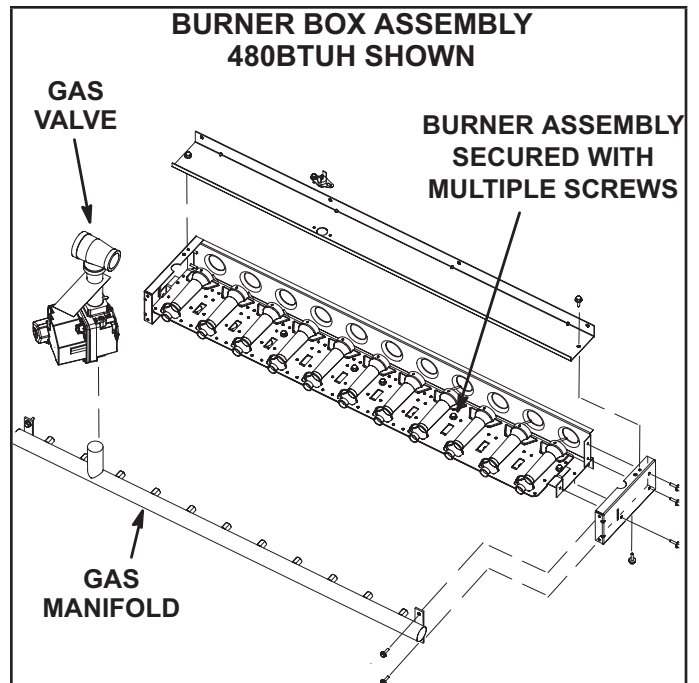

FIGURE 30

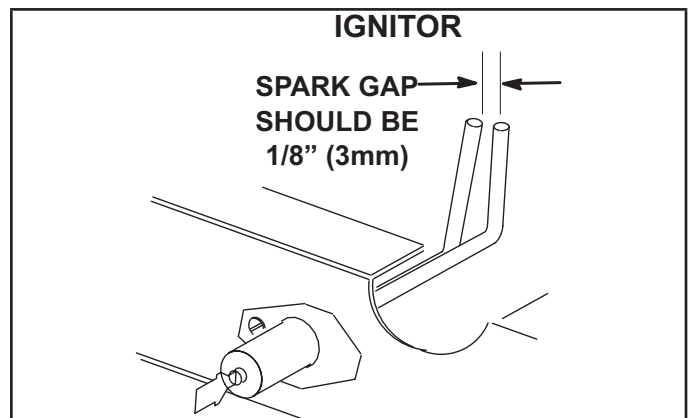

FIGURE 31

TABLE 16

Dimension	Unit Btuh Input	Length - in. (mm)	
		Ignitor	Sensor
A	260K	7-3/4 (197)	11 (279)
B	360K	5 (127)	5-1/2 (140)
C	480K	2-1/4 (57)	2-3/4 (70)

D-Combustion Air Inducer (Gas Units)

A combustion air proving switch checks combustion air inducer operation before allowing power to the gas controller. Gas controller will not operate if inducer is obstructed.

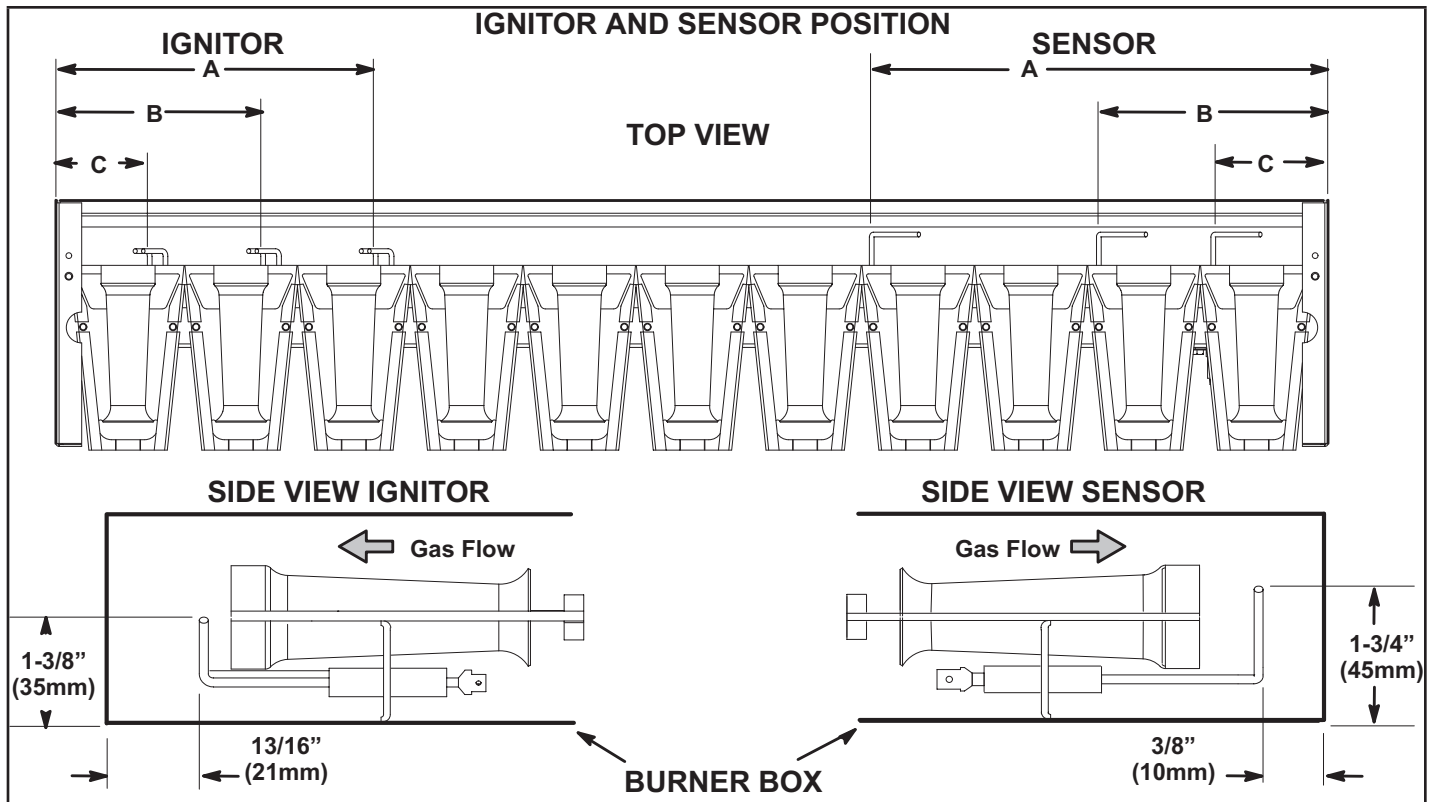

FIGURE 32

Under normal operating conditions, the combustion air inducer wheel should be checked and cleaned prior to the heating season. However, it should be examined periodically during the heating season to establish an ideal cleaning schedule. With power supply disconnected, the condition of the inducer wheel can be determined by looking through the vent opening.

Clean combustion air inducer as follows:

- 1 - Shut off power supply and gas to unit.
- 2 - Disconnect pressure switch air tubing from combustion air inducer port.
- 3 - Remove and retain screws securing combustion air inducer to flue box. Remove and retain two screws from bracket supporting vent connector. See FIGURE 33.
- 4 - Clean inducer wheel blades with a small brush and wipe off any dust from housing. Clean accumulated dust from front of flue box cover.
- 5 - Return combustion air inducer motor and vent connector to original location and secure with retained screws. It is recommended that the combustion air inducer gasket be replaced during reassembly.
- 6 - Clean combustion air inlet louvers on heat access panel using a small brush.

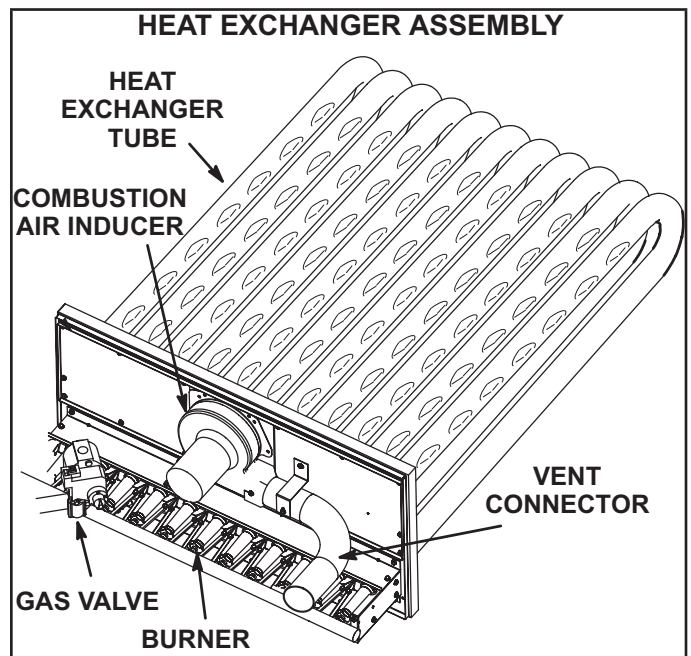

FIGURE 33

E-Flue Passageway and Flue Box (Gas Units)

- 1 - Remove combustion air inducer assembly as described in section D.
- 2 - Remove flue box cover. Clean with a wire brush as required.
- 3 - Clean tubes with a wire brush.

- 4 - Reassemble the unit. The flue box cover gasket and combustion air inducer gasket should also be replaced during reassembly.

F-Evaporator Coil

Inspect and clean coil at beginning of each cooling season. Clean using mild detergent or commercial coil cleaner. Flush coil and condensate drain with water taking care not to get insulation, filters and return air ducts wet.

G-Supply Air Blower Wheel

Annually inspect supply air blower wheel for accumulated dirt or dust. Turn off power before attempting to remove access panel or to clean blower wheel.

H-Condenser Coil

Clean condenser coil annually with detergent or commercial coil cleaner and inspect monthly during the cooling season. Access panels are provided on front and back of condenser section.

L-Replacement Fuses

F4 Fuses (LCX Only) - See the following tables for the proper replacement fuse sizes. To use the tables on page 54, find the model, voltage, and horsepower to identify MOP on TABLE 17. Using MOP, refer to TABLE 18 for replacement fuse details.

F10 fuse (LCX/LGX) - For F10 replacement fuses refer to TABLE 18.

TABLE 17 - Unit MOP (Maximum Overcurrent Protection)**

Model No.	LCX180S								
Voltage - 60Hz	208/230V - 3 Ph			460V - 3 Ph			575V - 3 Ph		
Horsepower	3	5	7.5	3	5	7.5	3	5	7.5
MOP	60	70	90	30	35	40	25	25	30
Model No.	LCX210S								
Voltage - 60Hz	208/230V - 3 Ph			460V - 3 Ph			575V - 3 Ph		
Horsepower	3	5	7.5	3	5	7.5	3	5	7.5
MOP	100	100	110	45	45	50	35	40	40
Model No.	LCX240S								
Voltage - 60Hz	208/230V - 3 Ph			460V - 3 Ph			575V - 3 Ph		
Horsepower	5	7.5	10	5	7.5	10	5	7.5	10
MOP	110	125	125	50	50	60	40	45	45
Model No.	LCX300S								
Voltage - 60Hz	208/230V - 3 Ph			460V - 3 Ph			575V - 3 Ph		
Horsepower	5	7.5	10	5	7.5	10	5	7.5	10
MOP	125	125	150	50	60	60	45	50	50

**factory configured (no electric heat or power exhaust)

TABLE 18 - F4 Fuse Replacement

MOP	Class	Amps	Volts	Qty
25	RK5	25	600	3
30	RK5	30	600	3
35	RK5	35	600	3
40	RK5	40	600	3
45	RK5	45	600	3
50	RK5	50	600	3
60	RK5	60	600	3
70	RK5	70	600	3
80	RK5	80	600	3
90	RK5	90	250	3
100	RK5	100	250	3
110	RK5	110	250	3
125	RK5	125	250	3
150	RK5	150	250	3
175	RK5	175	250	3

TABLE 19 - F10 Fuse Replacement Table

Model No.	LCX/LGX 180/210	LCX/LGX 240/300		LHX
Voltage - 60Hz	All	208/230	460, 575	All
Class	ULCC	ULCC	ULCC	ULCC
QTY	3	3	3	3
AMP	12	30	12	12
Voltage	600	600	600	600

Adusting Factory Unit Controller Settings

Use the mobile service app to adjust parameters; menu paths are shown in each table. Refer to the Unit Controller manual provided with each unit.

TABLE 20 shows factory settings (in degrees, % of fan CFM, etc.). Record adjusted settings on the label located inside the compressor access panel.

When field installing optional kits and accessories, the Unit Controller must be configured to identify the option before it will function. Refer to FIGURE 34 and FIGURE 35 to determine whether the Unit Controller configuration I.D. must change. To configure the option, use MAIN MENU > SETUP > INSTALL menu path. Press SAVE until CONFIGURATION ID 1 or 2 appears depending on the option installed. Change the appropriate character in the configuration I.D. For example, when an economizer is installed using a single enthalpy sensor, change configuration I.D. 1, the second character, to "S".

TABLE 20 - 581318-01

LCX/LGX/LHX Staged Blower Parameters								
Parameter	Factory Setting						Field Setting	Description
	LCX/LGX				LHX			
	180S	210S	240S	300S	180S	240S		
Note: Any changes to Smoke CFM setting must be adjusted before the other CFM settings. Use SETTINGS > RTU OPTIONS > EDIT PARAMETERS (CFM)								
12	6000	7000	8000	10000	6000	8000	CFM	Blower CFM during smoke detection.
SETUP > TEST & BALANCE (can also use SETTINGS > RTU OPTIONS > BLOWER > SPEEDS) (CFM)								
17	3900	4550	5200	6500	3900	5200	CFM	Blower CFM during COOLING LOW operation.
14	6000	7000	8000	10000	5400	7200	CFM	Blower CFM during COOLING HIGH operation.
13	6000	7000	8000	10000	6000	8000	CFM	Blower CFM during Heating operation.
18	6000	7000	8000	10000	6000	8000	CFM	Blower CFM during ventilation.
SETUP > TEST & BALANCE (can also use SETTINGS > RTU OPTIONS > DAMPER) (%)								
9	0%	0%	0%	0%	0%	0%	%	Damper min. position during LOW blower operation.
132	0%	0%	0%	0%	0%	0%	%	Damper min. position during HIGH blower operation
215	50%	50%	50%	50%	50%	50%	%	Min. damper % for stg 1 power exhaust operation.
SETTINGS > RTU OPTIONS > EDIT PARAMETERS (%)								
29	101	101	101	101	101	101	% Open	Damper minimum position during G blower operation.*
219	75	75	75	75	75	75	%	Min. damper % for stg 2 power exhaust operation.
216	10	10	10	10	10	10	%	Deadband % for stage 1 power exhaust operation.
220	10	10	10	10	10	10	%	Deadband % for stage 2 power exhaust operation.
224	100	100	100	100	100	100	Sec.	Stage 1 power exhaust off-delay in seconds.
30	70	70	70	70	70	70	% Speed	Minimum blower speed % for stage 2 power exhaust operation.

Configuration ID 1

1 2 3 4 5 6 7 8

Humiditrol [1]

Not Installed = **N**
 Humiditrol Installed = **H**
 Unconfigured = **U**

Economizer [2]

Not Installed = **N**
 Motorized Outdoor Air
 Damper Only = **M**
 Economizer - Temperature = **T**
 Economizer Global = **G**
 Economizer - Single
 Enthalpy = **S**
 Economizer - Dual Enthalpy = **D**
 Unconfigured = **U**

Power Exhaust [3]

Not Installed = **N**
 Single-Stage = **S**
 Dual-Stage = **D**
 Unconfigured = **U**

Power Exhaust Control [4]

Not Installed = **N**
 Damper Position = **A**
 A34 Pressure Sensor = **C**

[8] Outdoor Air CFM Control

N = Not applicable (for future use)
L = Outdoor Air Control Installed with A24 Sensor set for low range.
M = Outdoor Air Control Installed with A24 Sensor set for medium range.
H = Outdoor Air Control Installed with A24 Sensor set for high range.

[7] System Blower Subtype

N = Not applicable
B = VFD Belt Drive Blower (MODBUS)
H = Direct-Plus Blower (MODBUS)
L = ECM Direct-Drive Blower (PWM)

[6] Blower Variable Frequency Drive Bypass

N = Not Installed
A = Automatic Bypass
M = Manual Bypass
U = Unconfigured

[5] Network Module

N = Not Installed
L = LonTalk (Lennox)

FIGURE 34

Configuration ID 2

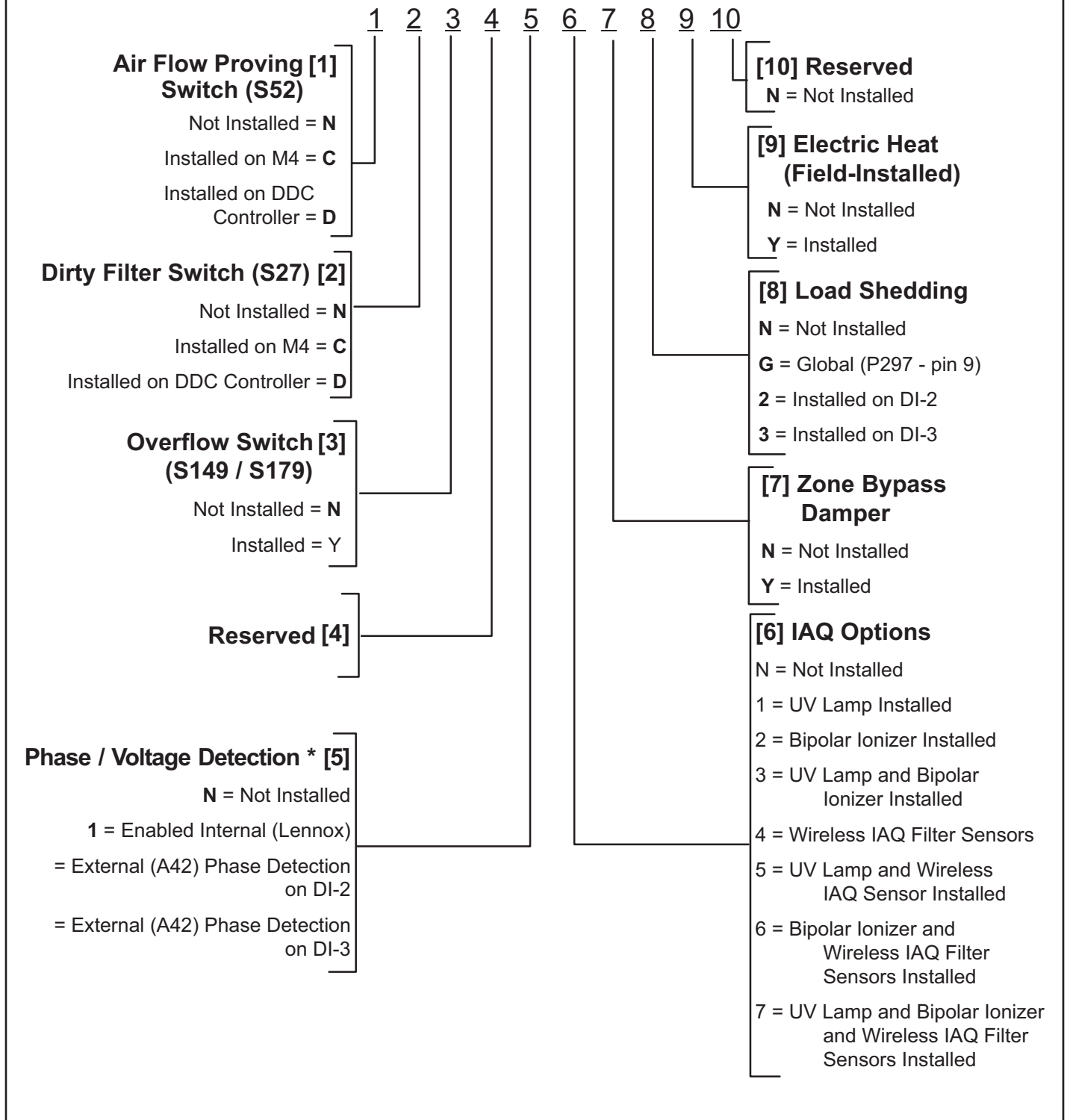

FIGURE 35

Decommissioning

Before carrying out this procedure, it is essential that the technician is completely familiar with the equipment and all its detail. It is recommended good practice that all refrigerants are recovered safely.

Prior to the task being carried out, an oil and refrigerant sample shall be taken in case analysis is required prior to re-use of recovered refrigerant. It is essential that electrical power is available before starting decommissioning.

- a) Become familiar with the equipment and its operation.
- b) Isolate system electrically.
- c) Before attempting the procedure, ensure that:
 - mechanical handling equipment is available, if required, for handling refrigerant cylinders;
 - all personal protective equipment is available and being used correctly;
 - the recovery process is supervised at all times by a competent person;
 - recovery equipment and cylinders conform to the appropriate standards.
- d) Pump down refrigerant system, if possible.
- e) If a vacuum is not possible, make a manifold so that refrigerant can be removed from various parts of the system.
- f) Make sure that cylinder is situated on the scales before recovery takes place.
- g) Start the recovery machine and operate in accordance with instructions.
- h) Do not overfill cylinders (no more than 80% volume liquid charge).
- i) Do not exceed the maximum working pressure of the cylinder, even temporarily.
- j) When the cylinders have been filled correctly and the process completed, make sure that the cylinders and the equipment are removed from site promptly and all isolation valves on the equipment are closed off.
- k) Recovered refrigerant shall not be charged into another REFRIGERATING SYSTEM unless it has been cleaned and checked.



IMPORTANT

Equipment shall be labelled stating that it has been decommissioned and emptied of refrigerant. The label shall be signed and dated. Ensure that there are labels on the equipment that state the flammability of the refrigerant used.

START-UP REPORT

Job Name: _____
 Store No. _____ Start-Up Date: _____
 Address: _____
 City: _____ State: _____
 Start-Up Contractor: _____
 Technician: _____
 Model No.: _____
 Serial No.: _____
 RTU No.: _____ Catalog No.: _____

Inspections and Checks			
Damage?	Yes	No	R454B <input type="checkbox"/>
If yes, reported to: _____			
Verify factory and field-installed accessories.			
Check electrical connections. Tighten if necessary.			
Supply voltage: L1-L2 _____ L1-L3 _____ L2-L3 _____			
If unit contains a 208-230/240 volt transformer:			
Check primary transformer tap <input type="checkbox"/>			
Transformer secondary voltage: _____			

Cooling Checks												
Compressor Rotation <input type="checkbox"/> Ambient Temp. _____ Return Air Temp. _____ Supply Air Temp. _____												
	Compressor Amps			Compressor Volts			Pressures		Condenser Fan Amps			CC Heater Amps
	L1	L2	L3	L1-L2	L1-L3	L2-L3	Disch.	Suct.	L1	L2	L3	L1
1												
2												
3												
4												

Blower Checks			
Pulley/Belt Alignment <input type="checkbox"/>	Blower Rotation <input type="checkbox"/>		
Set Screws Tight <input type="checkbox"/>	Belt Tension <input type="checkbox"/>		
Nameplate Amps: _____		Volts: _____	
Motor	Amps	Volts	
	L1 _____	L1-L2 _____	
	L2 _____	L1-L3 _____	
	L3 _____	L2-L3 _____	

Heating Checks - Electric							
Return Air Temp.: _____ Supply Air Temp.: _____							
Limits Operate: <input type="checkbox"/>							
	Amps						
	L1	L2	L3		L1	L2	L3
1				10			
2				11			
3				12			
4				13			
5				14			
6				15			
7				16			
8				17			
9				18			

Heating Checks - Gas		
Fuel type: Nat. <input type="checkbox"/> LP <input type="checkbox"/> Inlet Pressure: _____ in. w.c.		
Return Air Temp.: _____ Supply Air Temp.: _____		
Altitude: _____ Primary Limits Operate: <input type="checkbox"/>		
CO ₂ %: _____		
Gas Valve	Manifold Pressure	
	Low Fire	High Fire
GV1		
GV2		

Accessory Checks	
Power Exhaust Amps	
1 _____	2 _____ None <input type="checkbox"/>
Economizer Operation	
Min. Pos. <input type="checkbox"/>	Motor travel full open/close <input type="checkbox"/>

Control Type