



**NOTE - EDA is not applicable to variable-capacity outdoor units!**



# Humiditrol Enhance Dehumidification Accessory (EDA) Units

*Installation, Setup and User Guide*

# Table of Contents

- 1. General..... 2**
  - 1.1. Shipping and Packing List.....2
  - 1.2. Additional Parts Required .....3
  - 1.3. Introduction .....3
    - 1.3.1. CS7500 Thermostat ..... 3
    - 1.3.2. Lennox® Communicating Family of Thermostats ..... 3
    - 1.3.3. Operation Overview ..... 3
    - 1.3.4. Operation Notes ..... 4
  - 1.4. Wiring Diagram Locater .....4
  - 1.5. Decision Tree .....5
  - 1.6. Unit Dimensions .....6
  - 1.7. Installation Configuration.....7
    - 1.7.1. Horizontal and Up-flow ..... 7
    - 1.7.2. Down-flow ..... 8
  - 1.8. Component Functions .....10
    - 1.8.1. Charge Compensator..... 10
    - 1.8.2. Check/Flow Restrictor..... 10
    - 1.8.3. Valve Assembly ..... 10
- 2. Installation ..... 11**
  - 2.1. Information ..... 11
    - 2.1.1. Refrigeration..... 11
    - 2.1.2. Releasing Air Charge ..... 11
    - 2.1.3. Refrigerant Line Connections..... 11
  - 2.2. Electrical Wiring ..... 11
  - 2.3. Humiditrol Installation and Checkout Flow Chart ..... 17
  - 2.4. Leak Testing, Evacuating, Charging..... 18
    - 2.4.1. 3-Way Diverting Valve Operation ..... 18
    - 2.4.2. Leak Testing, Evacuating, Charging..... 19
  - 2.5. Insulating and Sealing the Unit ..... 19
  - 2.6. Other System Components..... 19
    - 2.6.1. Blower Control..... 19
    - 2.6.2. Thermostat and Sensor..... 19

- 2.7. Using Humiditrol Comfort Adjust ..... 19
- 2.8. Dehumidification Requirements ..... 20
- 3. Enabling Thermostats for Humiditrol..... 20**
  - 3.1. CS7500 Residential Thermostat ..... 20
  - 3.2. Lennox® Communicating E30 and S30 Thermostats ..... 21
  - 3.3. Lennox® Communicating M30 Thermostat..... 21
- 4. Modes of Operation ..... 21**
  - 4.1. Dehumidification Mode (Cooling ON)..... 21
  - 4.2. Cooling Mode (Dehumidification OFF)..... 22
  - 4.3. Heating Mode (Heat Pump Applications) ..... 22
- 5. Air Resistance ..... 22**
- 6. Thermostat Demand Signal..... 23**
- 7. Checklist ..... 24**

## 1. GENERAL

### 1.1. Shipping and Packing List

**Table 1. Packing List**

| Quantity | Description                                                                                                                                     |
|----------|-------------------------------------------------------------------------------------------------------------------------------------------------|
| 1        | Humiditrol® Enhanced Dehumidification Accessory (EDA), EDA-024B (94M41), EDA-036C (94M42) or EDA-060D (94M43)                                   |
| 1        | Bag assembly (includes check/flow restrictor for use on Humiditrol coil, and Humiditrol EDA notification label).                                |
| 1        | Outdoor fan relay and wiring harness (used in select applications. Refer to system wiring diagrams pages 18 to 21 for applicable applications). |
| 1        | Installation Instruction                                                                                                                        |
| 1        | Warranty (W-772-L8-04)                                                                                                                          |

## 1.2. Additional Parts Required

Separately-ordered components are restricted to those listed in the Product Specifications and the price book

**Table 2. Additional Parts**

| Quantity             | Description                                                                                                                     |
|----------------------|---------------------------------------------------------------------------------------------------------------------------------|
| Application specific | Outdoor Temperature Sensor (X2658)                                                                                              |
|                      | 75VA 24VAC indoor unit transformer (12P61) is required when the Humiditrol unit is installed with a two-stage heat pump system. |
|                      | Humiditrol Insulation and Piping Kit (refer to “Figure 1. Decision Tree” on page 5).                                            |
|                      | Humiditrol Zoning Accessory (39W67). Required when installing in system with Harmony III zoning system.                         |

Humiditrol is compatible with the following Lennox thermostats:

**Table 3. Compatible Lennox Thermostats**

| Description                                              |
|----------------------------------------------------------|
| CS7500 thermostat (13H14)                                |
| Lennox® Communicating E30 Smart Thermostat (15S64)       |
| Lennox® Communicating M30 Thermostat (15Z69)             |
| Lennox® Communicating S30 Ultra Smart Thermostat (12U67) |

## IMPORTANT

The approved application for the Humiditrol unit is restricted to those listed in the Product Specifications and price book

**NOTE:** Due to Lennox’ ongoing commitment to quality, features and options are subject to change without notice and without incurring liability. Improper installation, adjustment, alteration, service or maintenance can cause property damage or personal injury. Installation and service must be performed by a qualified installer and servicing agency.

## 1.3. Introduction

Humiditrol® is designed for installation with a Lennox HFC-410A split-system outdoor unit and an air handler or a furnace with a variable speed blower. It is designed for indoor installations only in either up-flow or horizontal air discharge applications.

**NOTE:** Humiditrol is not compatible with variable-capacity outdoor units!

- Humiditrol is for use only on HFC-410A systems with thermal expansion valve installed.
- Prior to installation, study the decision tree (see “Figure 1. Decision Tree” on page 5) to confirm that all application requirements for Humiditrol installation are met.

- Low ambient pressure switch type control option can be applied to this type of system down to 30°F. For low ambient kit part numbers, refer to the Product Specifications accessories section.

**NOTE:** The low ambient control option (down to 0°F) is not compatible with Humiditrol.

Before beginning installation, be sure the HVAC system components are compatible with the Humiditrol. See “Figure 1. Decision Tree” on page 5 for the system decision tree that describes compatible components of the system. One of the following thermostats is required for the Humiditrol system:

### 1.3.1. CS7500 Thermostat

**NOTE:** When wiring the thermostat into the system, be sure these requirements are met:

- Minimum 18 gauge thermostat wire is used.
- Maximum thermostat wire run length does not exceed 300 feet (90 m).
- Total load from any thermostat connection is less than 1 amp.

### 1.3.2. Lennox® Communicating Family of Thermostats

**NOTE:** When wiring the thermostat into the system, be sure these requirements are met:

- Minimum 18 gauge thermostat wire is used.
- Maximum thermostat wire run length does not exceed 1500 feet (455 m)
- Total load from any thermostat connection is less than 1 amp.

### 1.3.3. Operation Overview

**NOTE:** These instructions are intended as a general guide and do not supersede local codes in any way. Consult authorities having jurisdiction before installation.

- The Humiditrol unit operates to dehumidify, as required, when ambient temperatures are below 95°F.
- However, when temperatures reach 95°F, cooling and dehumidification demands are both serviced by increased cooling system run-time and does not use Humiditrol.
- Neither the CS7500 or any of the Lennox® Communicating family of thermostats will activate Humiditrol when the ambient temperature is at or above 95°F.
- Prior to system checkout, consider the outdoor ambient temperature since the Humiditrol will not operate above 95°F.
- Plan testing to be conducted when temperatures are between 65°F and 95°F to ensure proper Humiditrol set up and checkout operation.
- Humiditrol removes moisture from the indoor air at a greater rate than cooling alone. On a call for dehumidification, the indoor blower is slowed down, the outdoor fan is operated at a lower speed, and the compressor is upstaged to high-stage operation (two-stage units). The indoor cooling coil now operates as a

lower temperature removing additional humidity. At the same time, the Humiditrol three-way valves reposition themselves and the Humiditrol coil becomes active. This allows condenser heat to warm the indoor air to avoid excessive overcooling of the home. During cooling only (no Humiditrol operation) the Humiditrol coil is inactive.

- The Humiditrol coil is added to an HVAC system downstream of the indoor coil. In dehumidification mode, the coil becomes an extension of the outdoor coil and injects heat into the indoor air stream.
- This dehumidification mode allows significantly improved control of the humidity in the conditioned space with less chance of overcooling the space.
- The assembly includes a set of 3-way diverting valves which will either route refrigerant through the Humiditrol coil, or cause the refrigerant to bypass the that coil, depending on the mode of operation.

### 1.3.4. Operation Notes

- Dehumidification will not occur when the outdoor temperature is at or above 95°F or indoor temperature is at or below 65°F.
- When operating in cooling (or heat pump heating) mode, all temperatures and pressures will be as in a normal system.
- When the thermostat is in Humiditrol mode, and after a cooling demand has been satisfied but a dehumidification demand persists, and the room temperature is within the MIN, MID, MAX parameters described in Using Humiditrol Comfort Adjust (see “2.7. Using Humiditrol Comfort Adjust” on page 19), the air handlers will operate at reduced airflow with the compressor at high speed.
- When the unit is in the dehumidification mode, the thermostat will display “dehumidify or an icon” on the home screen.

## IMPORTANT

The Clean Air Act of 1990 bans the intentional venting of all refrigerants (CFC, HFC, and HCFC) as of July 1, 1992. Approved methods of recovery, recycling or reclaiming must be followed. Fines and/or incarceration may be levied for non-compliance

## !WARNING

Improper installation, adjustment, alteration, service or maintenance can cause property damage, personal injury or loss of life.

Installation and service must be performed by a licensed professional HVAC installer (or equivalent) or a service agency.

## !WARNING

Risk of explosion or fire.

Can cause injury or death.

Recover all refrigerant to relieve pressure before opening the system.

### 1.4. Wiring Diagram Locater

Table 4. Wiring Diagram Locater

| Thermostat                          | Indoor Unit Control                             | Outdoor Unit Control                             | Wiring Diagram                                                                                                                   |
|-------------------------------------|-------------------------------------------------|--------------------------------------------------|----------------------------------------------------------------------------------------------------------------------------------|
| CS7500 or Lennox® Communicating M30 | Non-communicating                               | Non-communicating                                | “Figure 11. CS7500 or M30 with any Non-Communicating Indoor and Outdoor Units” on page 12.                                       |
| CS7500 or Lennox® Communicating M30 | Non-communicating                               | Lennox Communicating wired as 24VAC Conventional | “Figure 12. CS7500 or M30 with Non-Communicating Indoor and Communicating Outdoor Units Wired for Non-Communicating” on page 13. |
| CS7500 or Lennox® Communicating M30 | Lennox Communicating wired as non-communicating | Lennox Communicating wired as non-communicating  | “Figure 13. CS7500 or M30 with Communicating Indoor and Outdoor Units with Both Wired Non-Communicating” on page 14.             |
| Lennox® Communicating E30           | Lennox Communicating wired as non-communicating | Lennox Communicating wired as non-communicating  | “Figure 14. E30 with both Indoor and Outdoor Communicating Units Wired for Non-Communicating” on page 15.                        |
| Lennox® Communicating S30           | Lennox Communicating                            | Lennox Communicating                             | “Figure 15. S30 Wired System for Communicating” on page 16.                                                                      |

# 1.5. Decision Tree

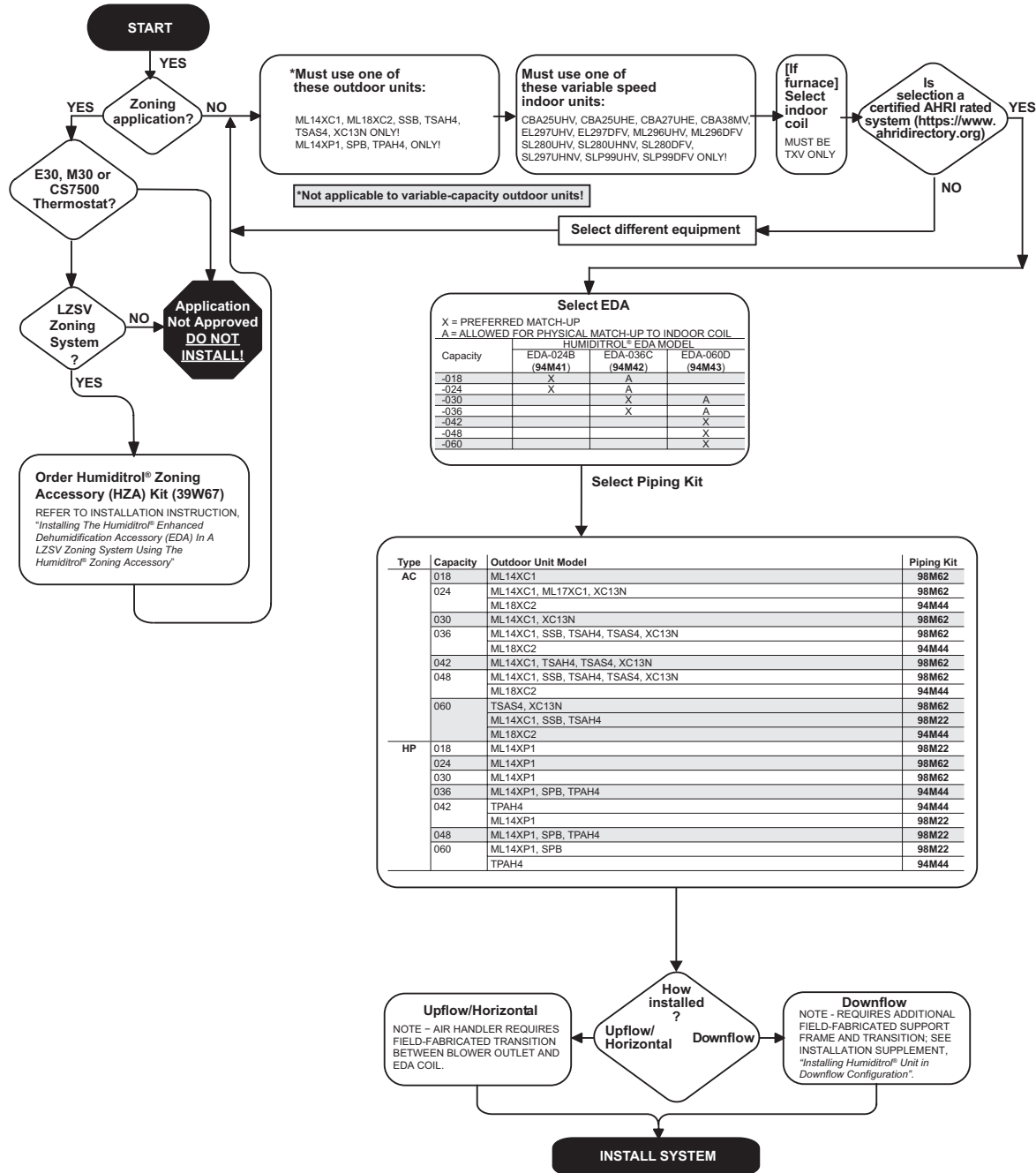

Figure 1. Decision Tree

## 1.6. Unit Dimensions

EDA Model Dimensions - Inches (mm)

| Dimension | EDA-024B     | EDA-036C     | EDA-060D     |
|-----------|--------------|--------------|--------------|
| <b>A</b>  | 17-1/2 (445) | 21 (533)     | 24-1/2 (622) |
| <b>B</b>  | 12-1/4 (311) | 12-1/4 (311) | 14 (356)     |
| <b>C</b>  | 16-1/8 (422) | 19-5/8 (498) | 23-1/8 (587) |
| <b>D</b>  | 16-1/8 (422) | 19-5/8 (498) | 23-1/8 (587) |
| <b>E</b>  | 1-3/8 (35)   | 3-1/8 (79)   | 4-7/8 (124)  |
| <b>F</b>  | 3-1/8 (79)   | 4-7/8 (124)  | 6-5/8 (168)  |
| <b>G</b>  | 3 (76)       | 3-1/4 (83)   | 4-3/4 (121)  |

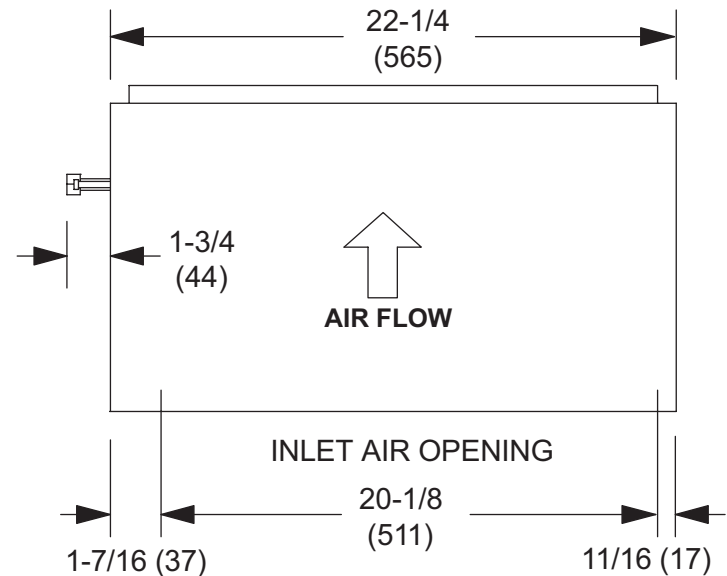
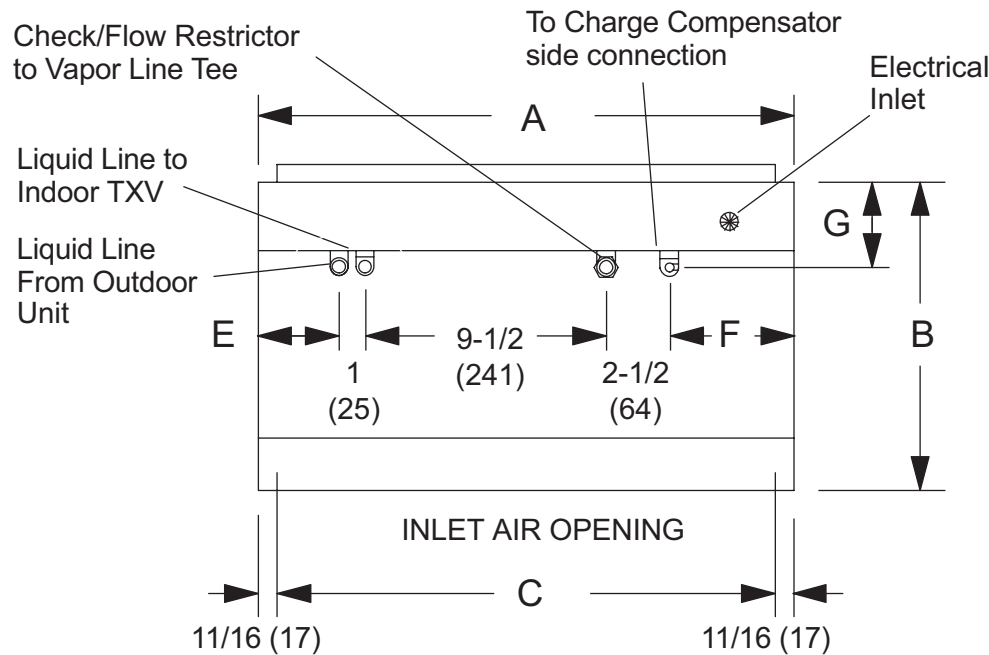
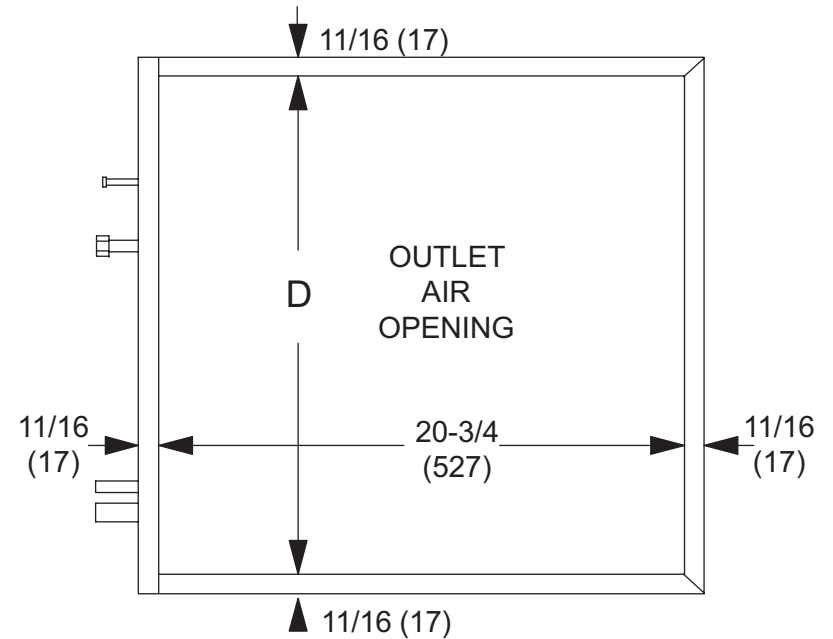

Figure 2. Unit Dimensions

## 1.7. Installation Configuration

### 1.7.1. Horizontal and Up-flow

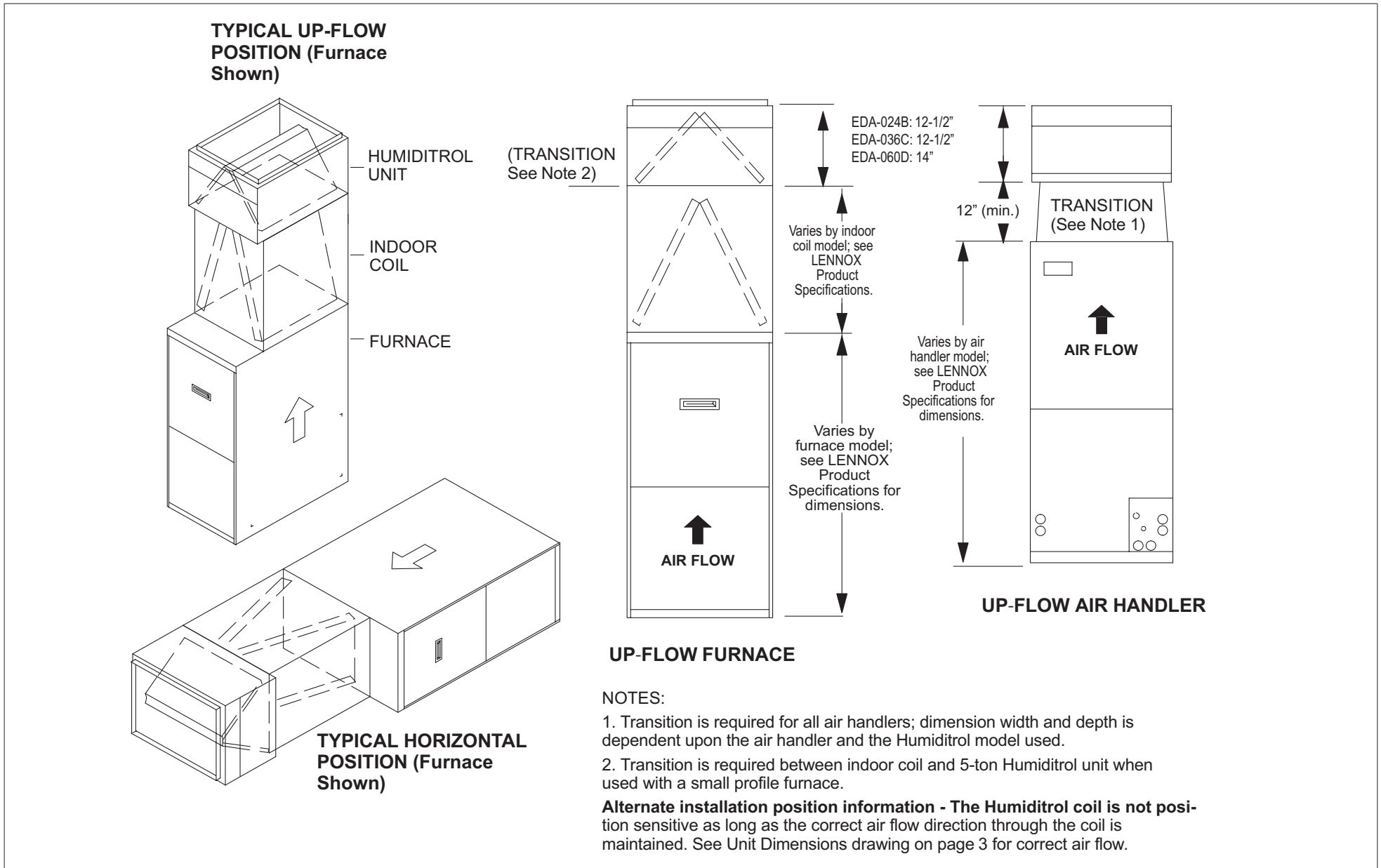

Figure 3. Installation Arrangements (Horizontal and Up-flow)

### 1.7.2. Down-flow

This accessory is designed for indoor installations in either up-flow or horizontal air discharge applications, however, the unit will function in the down-flow configuration, provided the instructions contained herein are followed.

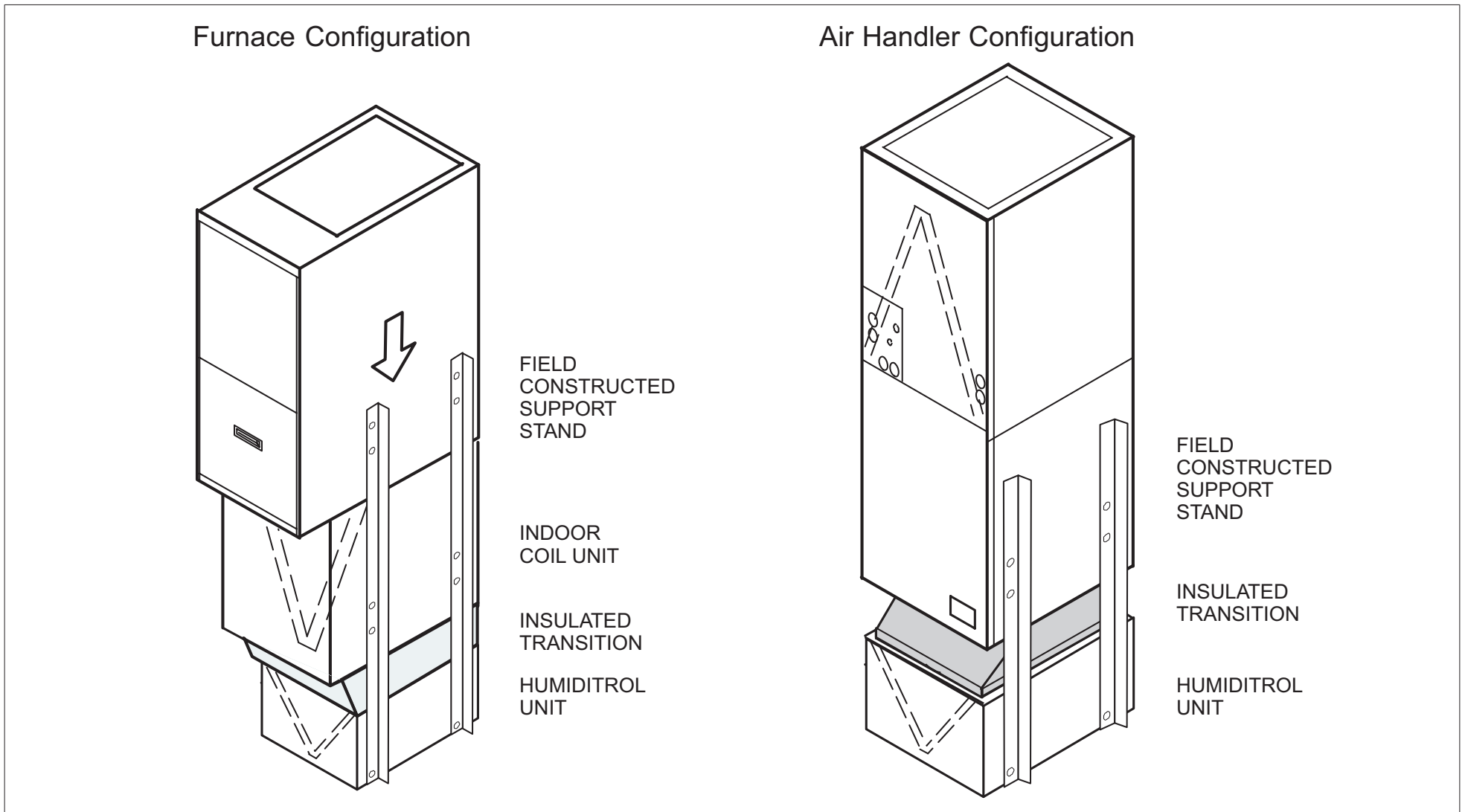
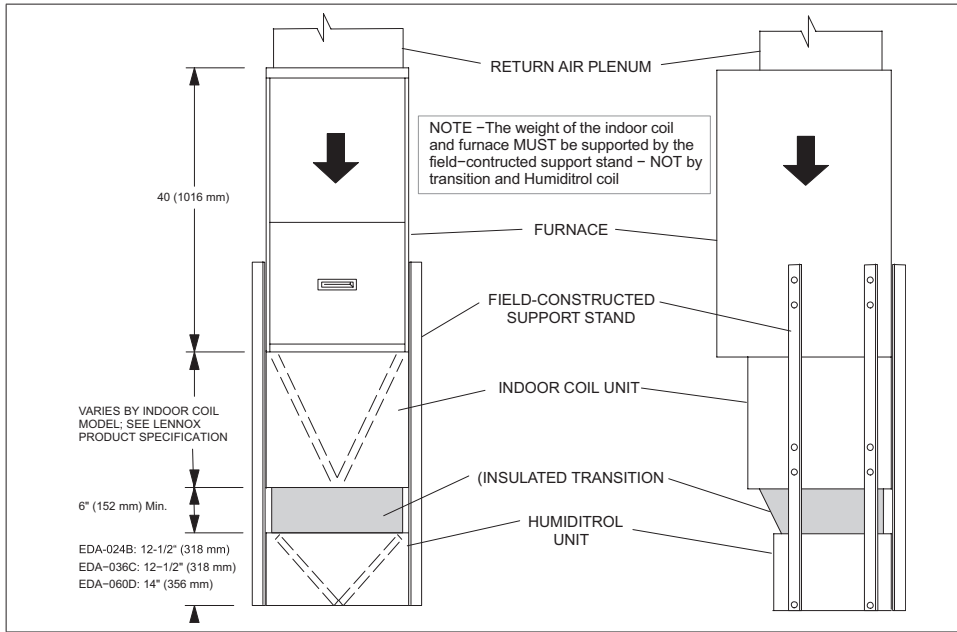
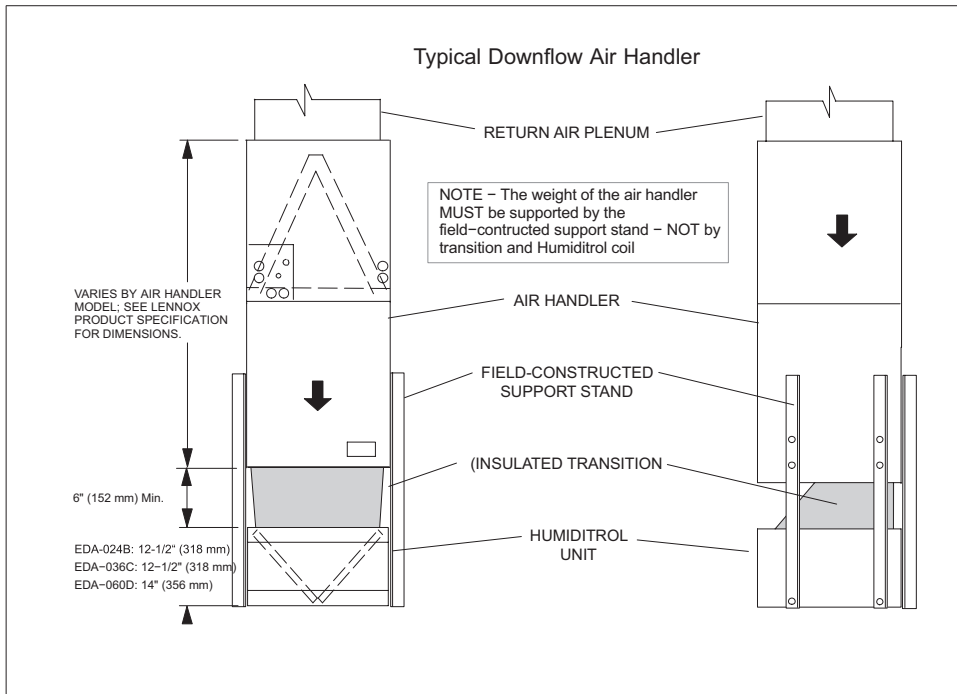

Figure 4. Typical Down-flow Configurations for both Air Handler and Gas Furnace

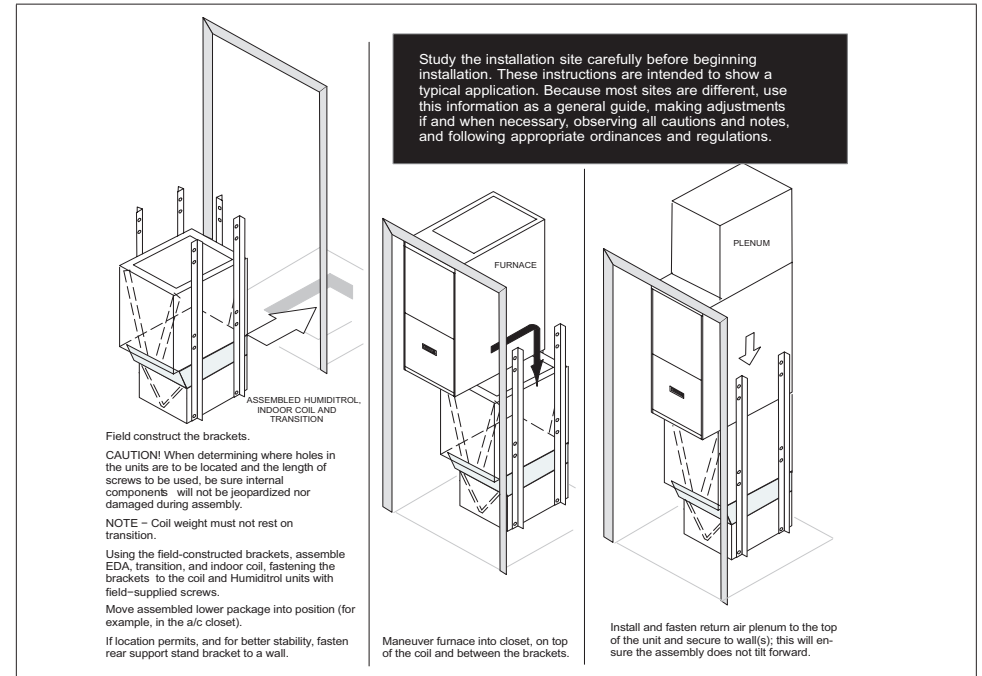



**Figure 5. Typical Down-flow Furnace**



**Figure 6. Typical Down-flow Air Handler**



**Figure 7. Typical Down-flow Furnace Installation**

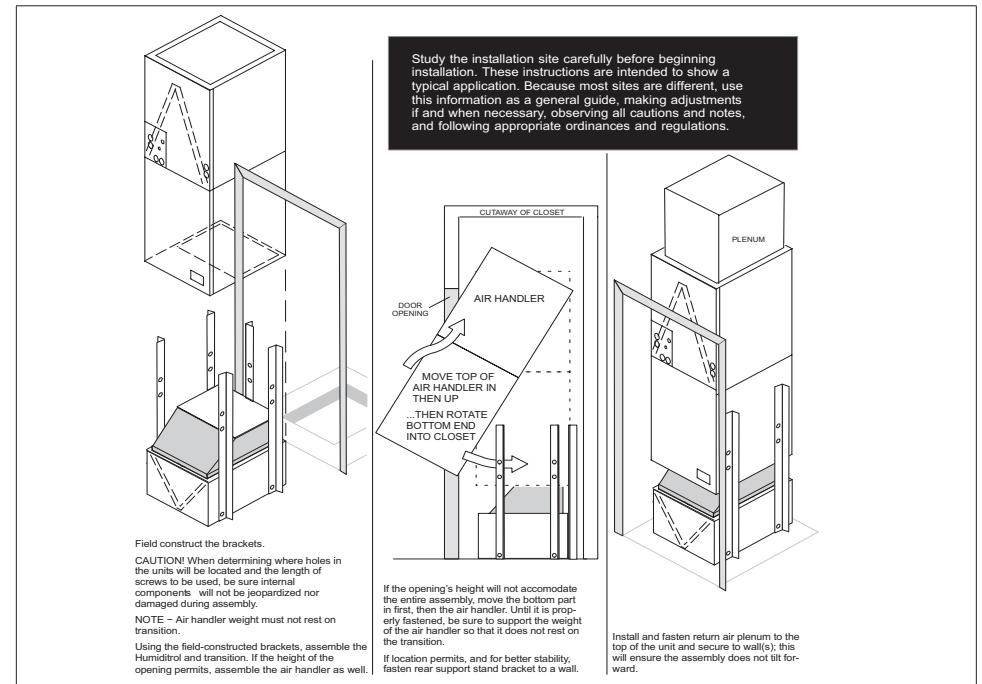

**Figure 8. Typical Down-flow Furnace Installation**

## 1.8. Component Functions

### 1.8.1. Charge Compensator

The charge compensator included in the Installation and Piping kit as shown in “Figure 17. Typical Installation (Horizontal Air Handler Shown)” on page 18 serves to maintain the proper amount of refrigerant circulating in certain systems. (Some systems do not require a charge compensator, but do require a similar Installation and Piping kit to connect into the system [see Product Specifications]).

The charge compensator stores excess refrigerant when the Humiditrol coil is active (dehumidifying) and returns it to the system during normal cooling or heating operations. When the Humiditrol coil is active, less charge is required to obtain the proper amount of sub-cooling because of the additional coil surface and the cooler air which passes over the Humiditrol coil.

### 1.8.2. Check/Flow Restrictor

The check function of the check/flow restrictor (shown in Figure 9) prevents refrigerant from flowing into the inactive components during times when the Humiditrol coil is inactive. The flow restrictor controls the rate of return of charge to the system from the charge compensator and the Humiditrol coil when the system changes from “Humiditrol coil active” to “Humiditrol coil inactive.”

### 1.8.3. Valve Assembly

The first valve of the diverting valve assembly (figure 10, E) directs the flow of refrigerant to either bypass the Humiditrol coil (Humiditrol coil is inactive) or pass through the Humiditrol coil (Humiditrol coil is active). The second valve (figure 10 F) directs the flow of refrigerant back to the liquid line when the first valve (E) allows flow through the Humiditrol coil. When the Humiditrol coil is inactive, the second valve (F) provides a vent path to the suction line, draining the Humiditrol coil and charge compensator of liquid refrigerant.

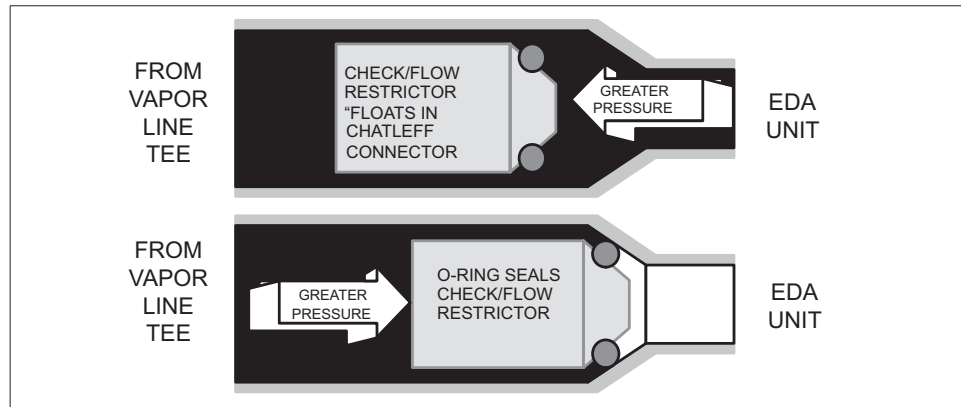

Figure 9. Check/Flow Restrictor Operation

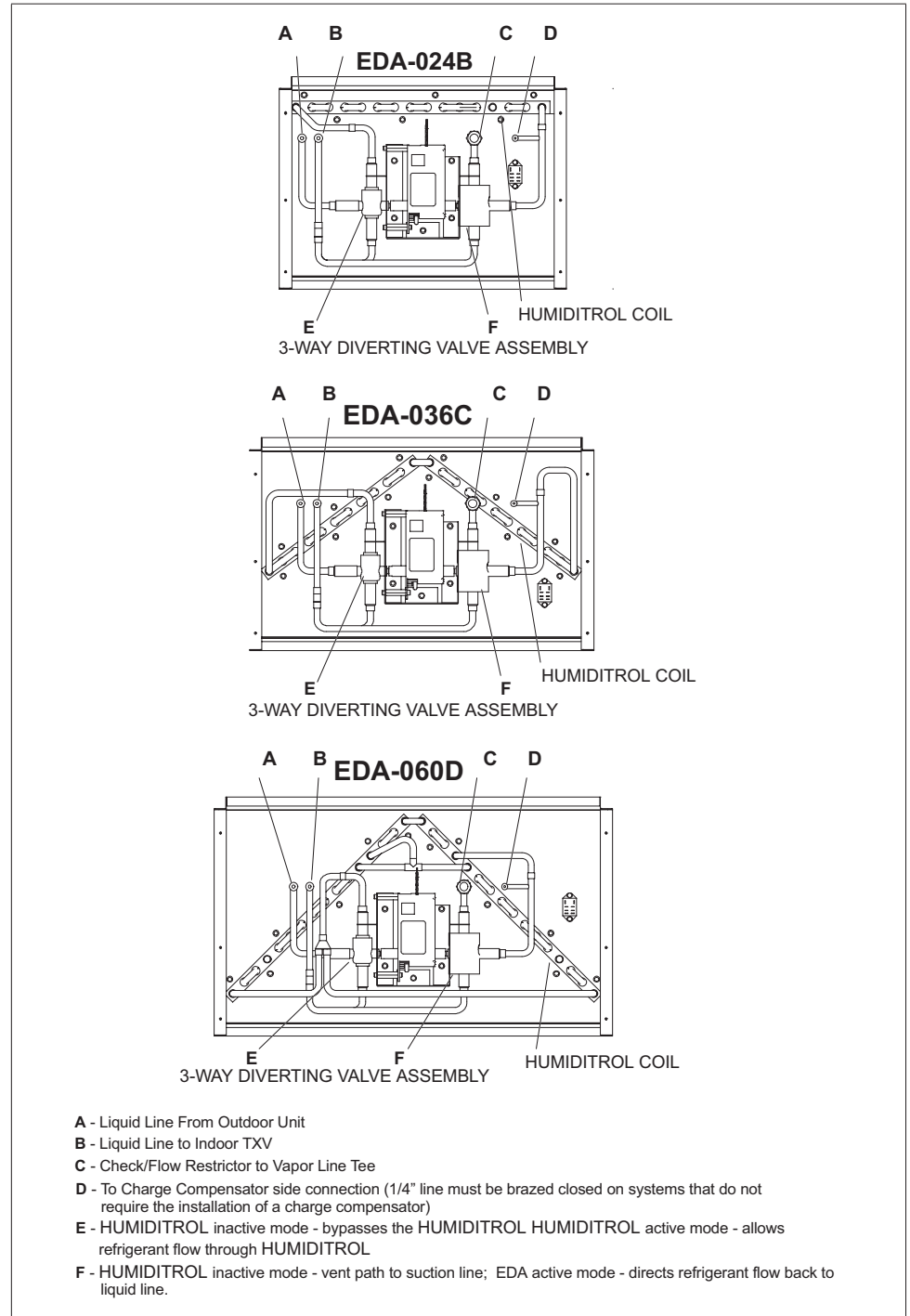

Figure 10. Humiditrol Unit Parts Arrangement

## 2. INSTALLATION

### 2.1. Information

#### **WARNING**

Risk of property damage, injury, or death.

Installation, adjustments, alterations, service and maintenance must be performed by a licensed professional service technician (or equivalent).

#### **CAUTION**

Physical contact with metal edges and corners while applying excessive force or rapid motion can result in personal injury. Be aware of, and use caution when working nearby these areas during installation or while servicing this equipment.

#### **CAUTION**

The Humiditrol coil is shipped from the factory pressurized with dry air. Pierce a hole in the coil's rubber plug vapor line seal to relieve the pressure before removing the seals.

#### 2.1.1. Refrigeration

All Humiditrol coils are shipped with a combination check/flow restrictor. The restrictor is provided in the bag assembly and must be installed. Refer to the appropriate high and/or low side installation instructions for information on the appropriate line sets. Refer to Lennox Refrigerant Piping guide (Corp. 9351-L9) for proper size, type, and application of field-fabricated lines.

#### 2.1.2. Releasing Air Charge

**NOTE:** *Humiditrol units are shipped from the factory with dry air as a holding charge.*

1. Ensure that the coil is void of pressure.
2. Remove the rubber plug from the lines.
3. If there is no pressure when the plugs are pierced, check the unit for leaks before continuing with the installation.

#### 2.1.3. Refrigerant Line Connections

When connecting lines, be careful to avoid damaging the 3-way diverting valve access panel. Place a wet rag against the piping plate and around the Humiditrol unit line connections. A wet rag heat shield must be in place during brazing to guard against damage to the paint.

### 2.2. Electrical Wiring

Review the diagrams before installation to ensure all necessary components are on hand at time of installation.

Connect the Humiditrol unit with the indoor and outdoor units, and to the thermostat. Be sure that the outdoor sensor is installed and connected to the CS7500 thermostat's outdoor sensor terminal block or that discharge air and/or outdoor air sensors are connected to the Lennox® Communicating indoor unit. The table below each wiring diagram shows the requirements for control wiring.

The Lennox® Communicating thermostat can use the outdoor sensor factory supplied and connected in Lennox® Communicating outdoor units.

| System type | NUMBER OF WIRES REQUIRED—Indoor unit to: |                                      |              | Thermostat to:     |
|-------------|------------------------------------------|--------------------------------------|--------------|--------------------|
|             | Humiditrol® EDA                          | CS7500 and Lennox® Communicating M30 | Outdoor Unit | Outdoor Air Sensor |
| 1 stage AC  | 3                                        | 7*                                   | 3            | 2                  |
| 2 stage AC  |                                          | 8*                                   | 4            |                    |
| 1 stage HP  |                                          | 8*                                   | 5            |                    |
| 2 stage HP  |                                          | 9*                                   | 6            |                    |

\*Includes conductor for 2-stage heat

A108

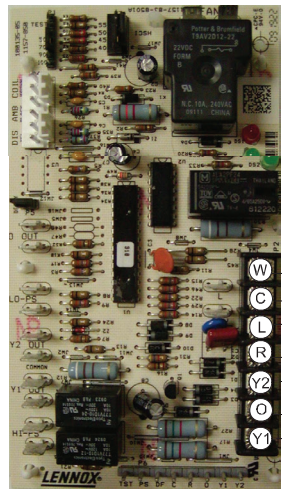

OUTDOOR UNIT DEFROST BOARD (HP)

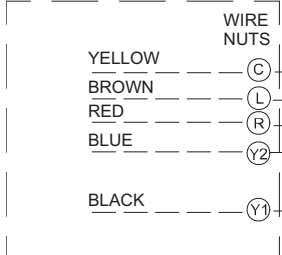

OUTDOOR UNIT CONTROL WIRES (AC)

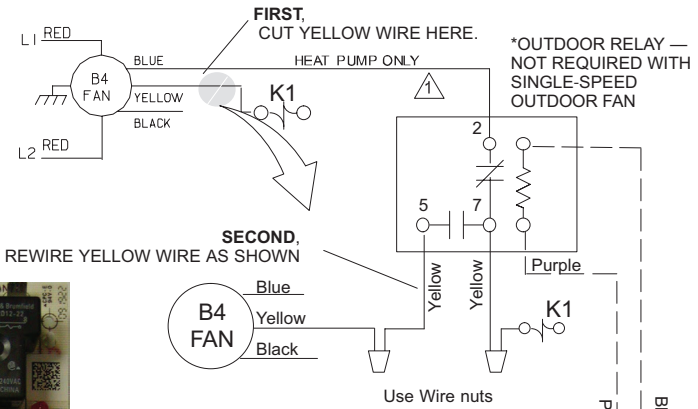

A92

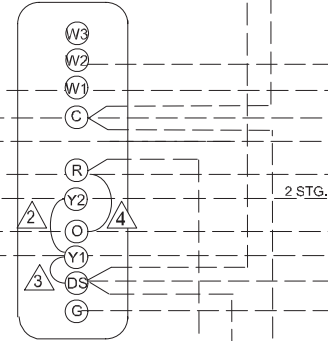

INDOOR UNIT 24 VOLT TERMINAL STRIP

A2

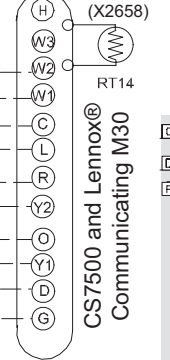

OUTDOOR SENSOR (X2658) RT14 CS7500 and Lennox® Communicating M30

- ⚠️ XP19-024 UNITS COME FACTORY WIRED FOR LOW OUTDOOR FAN SPEED ONLY. HIGH SPEED Y2 (BLUE WIRE) IS NOT CONNECTED. BE SURE TO CONNECT BLUE Y2 WIRE TO TERMINAL OF OUTDOOR RELAY.
- ⚠️ Y1—Y2 JUMPER - ONLY REMOVE IF 2-STAGE COOLING
- ⚠️ DS—Y1 JUMPER - MUST BE REMOVED FOR HUMIDITROL OPERATION
- ⚠️ HEAT PUMP APPLICATIONS ONLY - REMOVE R—O JUMPER.

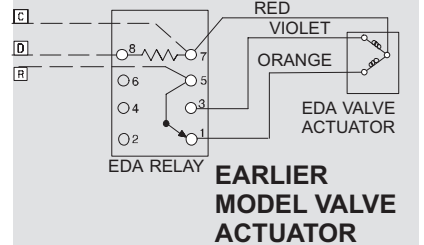

Humiditrol

1N4005 DIODE (shrink wrapped - diode is concealed in the wire.)

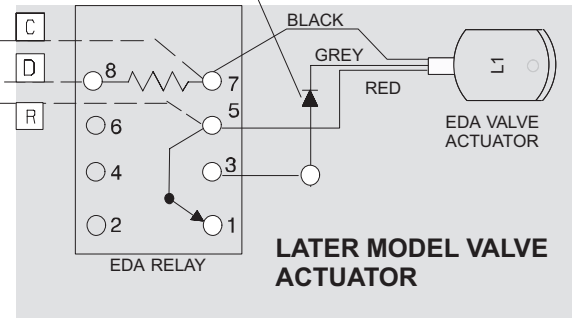

Humiditrol

Figure 11. CS7500 or M30 with any Non-Communicating Indoor and Outdoor Units

OUTDOOR UNITS (A175) - WIRE EITHER CONTROL IDENTICALLY  
EARLY CONTROL  
CURRENT CONTROL

A175

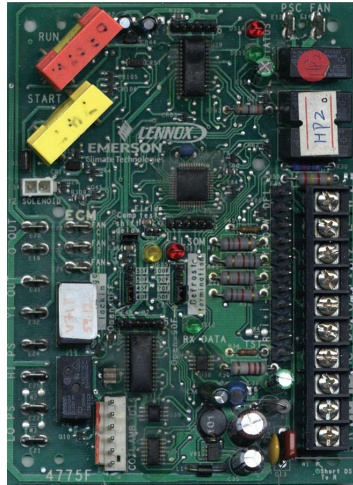

**Operation sequence for dehumidification**

1. REMOVE 24 VOLTS FROM DH AND/OR DS
2. THERMOSTAT CYCLES OUTDOOR UNITS TO Y2
3. INDOOR AND OUTDOOR FAN SPEEDS REDUCED

| NUMBER OF WIRES REQUIRED—Indoor unit to: |               |                                      |              | Thermostat to:     |
|------------------------------------------|---------------|--------------------------------------|--------------|--------------------|
| System Type                              | Humidtrol EDA | CS7500 and Lennox® Communicating M30 | Outdoor Unit | Outdoor Air Sensor |
| 1-stage AC                               | 3             | 7                                    | 4            | 2                  |
| 2-stage AC                               |               | 8                                    | 5            |                    |
| 1-stage HP                               |               | 9                                    | 6            |                    |
| 2-stage HP                               |               | 10                                   | 7            |                    |

⚠️ DS—R (W1) JUMPER - MUST BE CUT FOR HUMIDITROL OPERATION. SEE W1 JUMPER DETAIL.

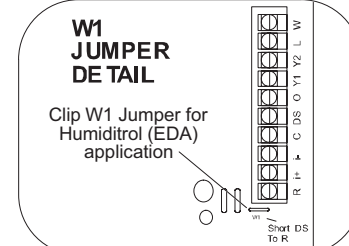

⚠️ DS—R TRACE ON A175 - MUST BE CUT FOR HUMIDITROL OPERATION. SEE TRACE CUT DETAIL.

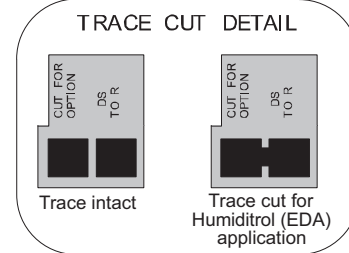

⚠️ DS TO R ON A92 - ON-BOARD LINK MUST BE CUT FOR DEHUMIDIFICATION.

⚠️ DS—Y1 JUMPER - MUST BE REMOVED FOR HUMIDITROL OPERATION

⚠️ HEAT PUMP APPLICATIONS ONLY - REMOVE R—O JUMPER.

⚠️ (2-STAGE ONLY) FOR HUMIDITROL OPERATION (EDA), CONNECT FIELD PROVIDED WIRE FROM DS ON A92 TO DS ON A175.

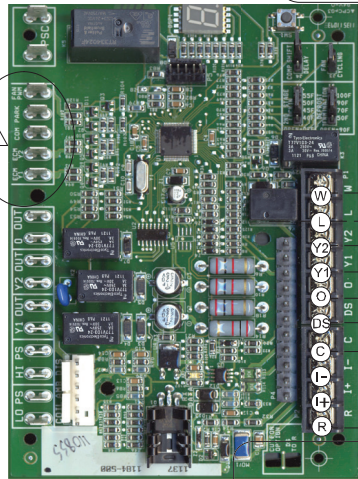

⚠️ SEE W1 JUMPER DETAIL

⚠️ SEE TRACE CUT DETAIL

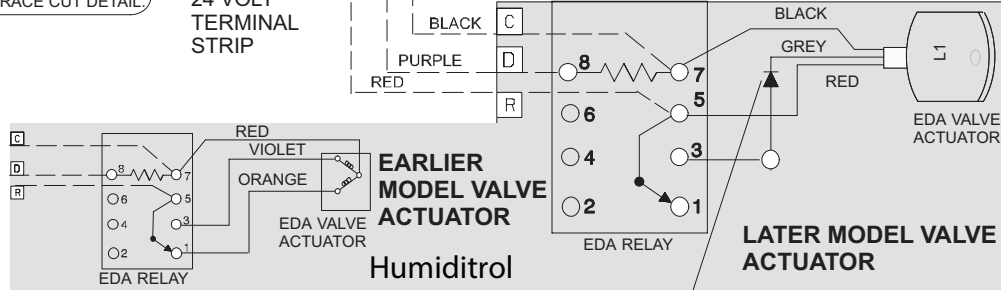
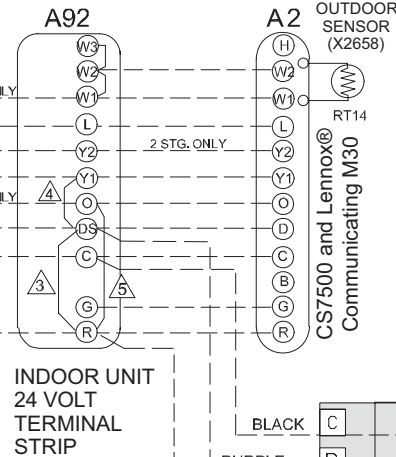

1N4005 DIODE (shrink wrapped - diode is concealed in the wire.)

Figure 12. CS7500 or M30 with Non-Communicating Indoor and Communicating Outdoor Units Wired for Non-Communicating

OUTDOOR UNITS (A175) - WIRE EITHER CONTROL IDENTICALLY  
EARLY CONTROL  
CURRENT CONTROL

A175

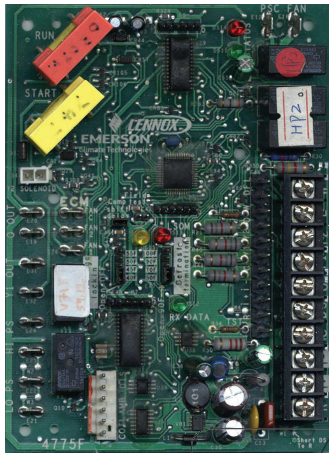

SEE W1 JUMPER DETAIL.

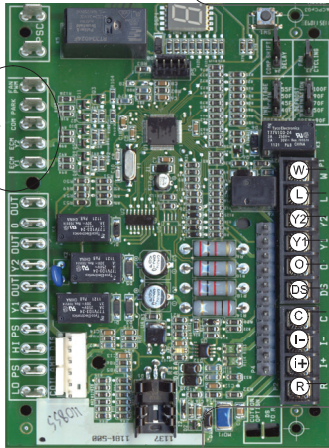

SEE TRACE CUT DETAIL.

**Operation sequence for dehumidification**

1. REMOVE 24 VOLTS FROM DH AND/OR DS
2. THERMOSTAT CYCLES OUTDOOR UNITS TO Y2
3. INDOOR AND OUTDOOR FAN SPEEDS REDUCED

| System Type | NUMBER OF WIRES REQUIRED—Indoor unit to: |     | Air Sensors (Optional)               |                     |   |   |
|-------------|------------------------------------------|-----|--------------------------------------|---------------------|---|---|
|             | Humiditrol                               | EDA | Outdoor unit                         | Outdoor / Discharge |   |   |
| 1-stage AC  | 3                                        |     | CS7500 and Lennox® Communicating M30 | 4                   | 2 | 2 |
| 2-stage AC  |                                          |     | 8                                    | 5                   |   |   |
| 1-stage HP  |                                          |     | 10                                   | 6                   |   |   |
| 2-stage HP  |                                          |     | 10                                   | 7                   |   |   |

A92

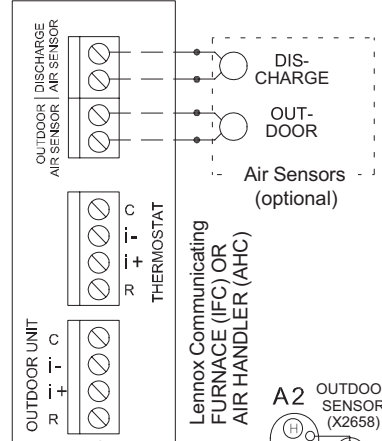

⚠️ DS-R (W1) JUMPER - MUST BE CUT FOR HUMIDITROL OPERATION. SEE W1 JUMPER DETAIL.

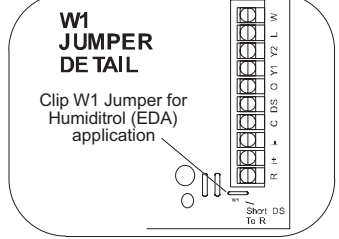

⚠️ DS-R TRACE - MUST BE CUT FOR HUMIDITROL OPERATION. SEE TRACE CUT DETAIL.

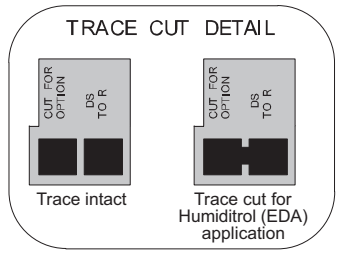

1N4005 DIODE (shrink wrapped - diode is concealed in the wire.)

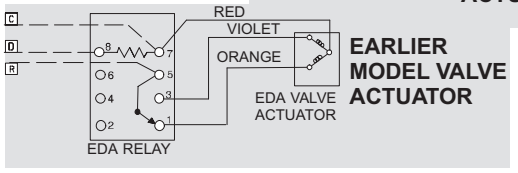
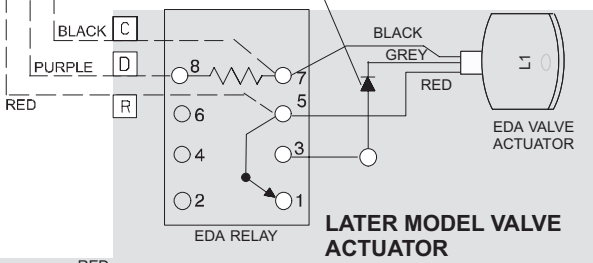

Humiditrol

Figure 13. CS7500 or M30 with Communicating Indoor and Outdoor Units with Both Wired Non-Communicating

OUTDOOR UNITS (A175) - WIRE EITHER CONTROL IDENTICALLY  
CURRENT CONTROL

A175

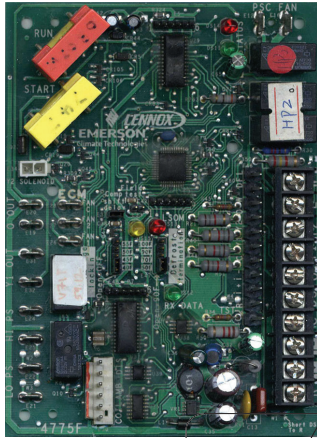

SEE W1 JUMPER DETAIL

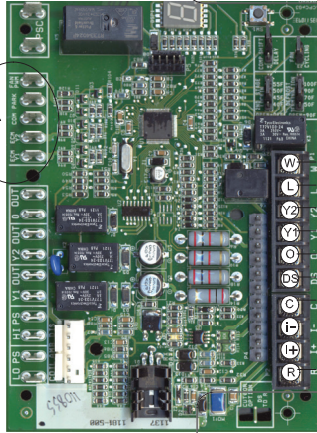

SEE TRACE CUT DETAIL

**Operation sequence for dehumidification**

1. REMOVE 24 VOLTS FROM DH AND/OR DS
2. THERMOSTAT CYCLES OUTDOOR UNITS TO Y2
3. INDOOR AND OUTDOOR FAN SPEEDS REDUCED

| System Type | NUMBER OF WIRES REQUIRED—Indoor unit to: |     |                           | Air Sensors (Optional) |           |
|-------------|------------------------------------------|-----|---------------------------|------------------------|-----------|
|             | Humiditrol                               | EDA | Lennox® Communicating E30 | Outdoor                | Discharge |
| 1-stage AC  | 3                                        |     | 8                         | 4                      | 2         |
| 2-stage AC  |                                          |     | 10                        | 5                      |           |
| 1-stage HP  |                                          |     | 8                         | 6                      |           |
| 2-stage HP  |                                          |     | 10                        | 7                      |           |

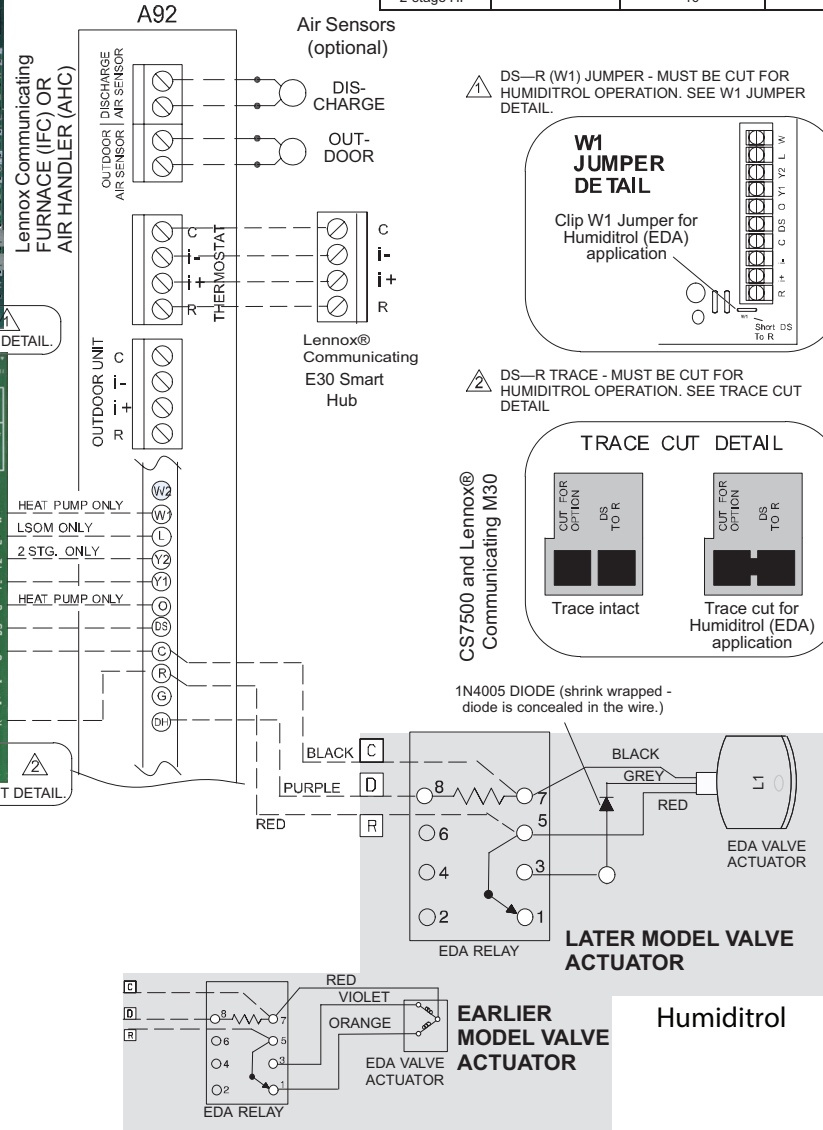
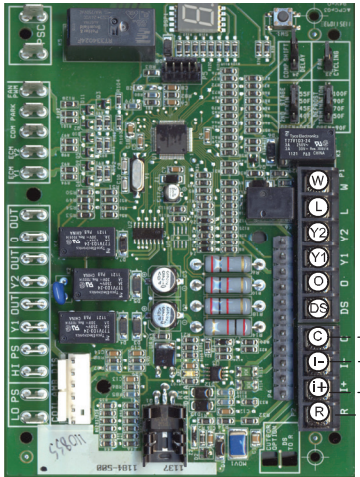

Figure 14. E30 with both Indoor and Outdoor Communicating Units Wired for Non-Communicating

OUTDOOR UNITS (A175) - WIRE EITHER CONTROL IDENTICALLY  
EARLY CONTROL  
CURRENT CONTROL



⚠ IN COMMUNICATING SYSTEM, THERMOSTAT DS INPUT IS NOT USED AND DEHUMIDIFICATION IS CONTROLLED VIA DEHUMIDIFICATION RELAY THAT CONTROLS 24VAC OUTPUT ON DH TERMINAL.

| System Type | NUMBER OF WIRES REQUIRED—Indoor unit to: |                           |              | Air Sensors (Optional) |         |
|-------------|------------------------------------------|---------------------------|--------------|------------------------|---------|
|             | Humiditrol EDA                           | Lennox® Communicating S30 | Outdoor unit | Discharge              | Outdoor |
| 1-stage AC  | 3                                        | 4                         | 4            | 2                      | 2       |
| 2-stage AC  |                                          |                           |              |                        |         |
| 1-stage HP  |                                          |                           |              |                        |         |
| 2-stage HP  |                                          |                           |              |                        |         |

Lennox Communicating FURNACE (IFC) OR AIR HANDLER (AHC)

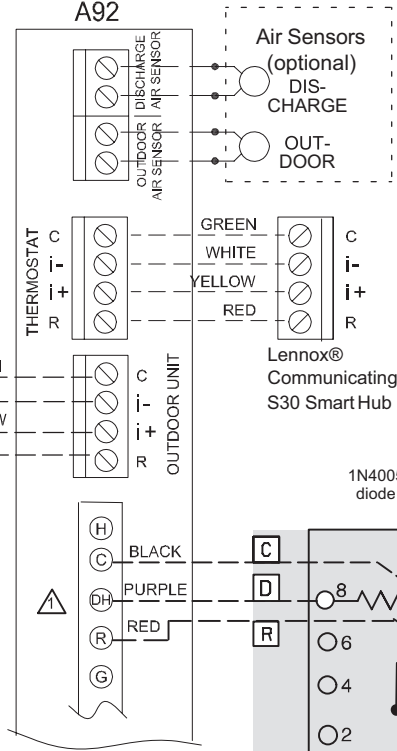

**Operation sequence for dehumidification**

1. REMOVE 24 VOLTS FROM DH AND/OR DS
2. THERMOSTAT CYCLES OUTDOOR UNITS TO Y2
3. INDOOR AND OUTDOOR FAN SPEEDS REDUCED

MAXIMUM TOTAL LENGTH OF ALL CONNECTIONS ON THE RSBUS IS LIMITED TO 1500FT. WIRE GAUGE OF RSBUS WIRE IS 18.

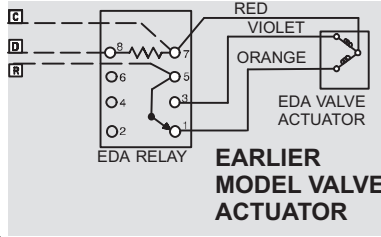

Humiditrol

1N4005 DIODE (shrink wrapped - diode is concealed in the wire.)

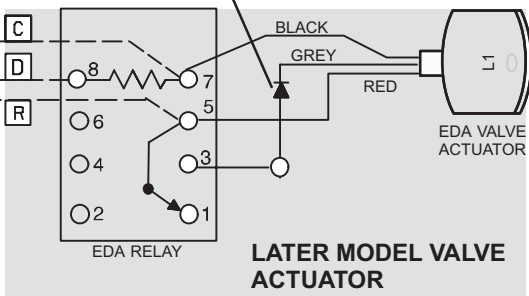

Humiditrol

Figure 15. S30 Wired System for Communicating



## 2.3. Humiditrol Installation and Checkout Flow Chart

Following the procedures reference in this section when installing the Humiditrol and associated components.

**Table 5. Required Parts for Specific Applications**

| Required Parts                                                                                                 | Application                          |                         |                                 |
|----------------------------------------------------------------------------------------------------------------|--------------------------------------|-------------------------|---------------------------------|
|                                                                                                                | Any non-zoning AC or Single Stage HP | Non-Zoning Two Stage HP | AC or HP and Harmony III Zoning |
| <i>NOTE: After confirming that all required parts per this table are available, proceed with installation.</i> |                                      |                         |                                 |
|                                                                                                                |                                      |                         |                                 |
| Humiditrol Unit with check/flow restrictor and label                                                           | Yes                                  | Yes                     | Yes                             |
| Thermostats: CS7500, Lennox® Communicating E30, M30 and S30 Smart Thermostat                                   | All                                  | All                     | CS7500 or M30 (see note)        |
| Outdoor Sensor (X2658, for non-communicating outdoor units)                                                    | Yes                                  | Yes                     | Yes                             |
| Insulation and Piping Kit                                                                                      | Yes                                  | Yes                     | Yes                             |
| 75VA Transformer (12P61)                                                                                       | —                                    | Yes                     | Yes (if two-stage HP)           |
| Humiditrol Zoning Accessory (39W67)                                                                            | —                                    | —                       | Yes                             |
| <i>NOTE: We recommend that for an all full communicating systems that the iHarmony® zoning system is used.</i> |                                      |                         |                                 |

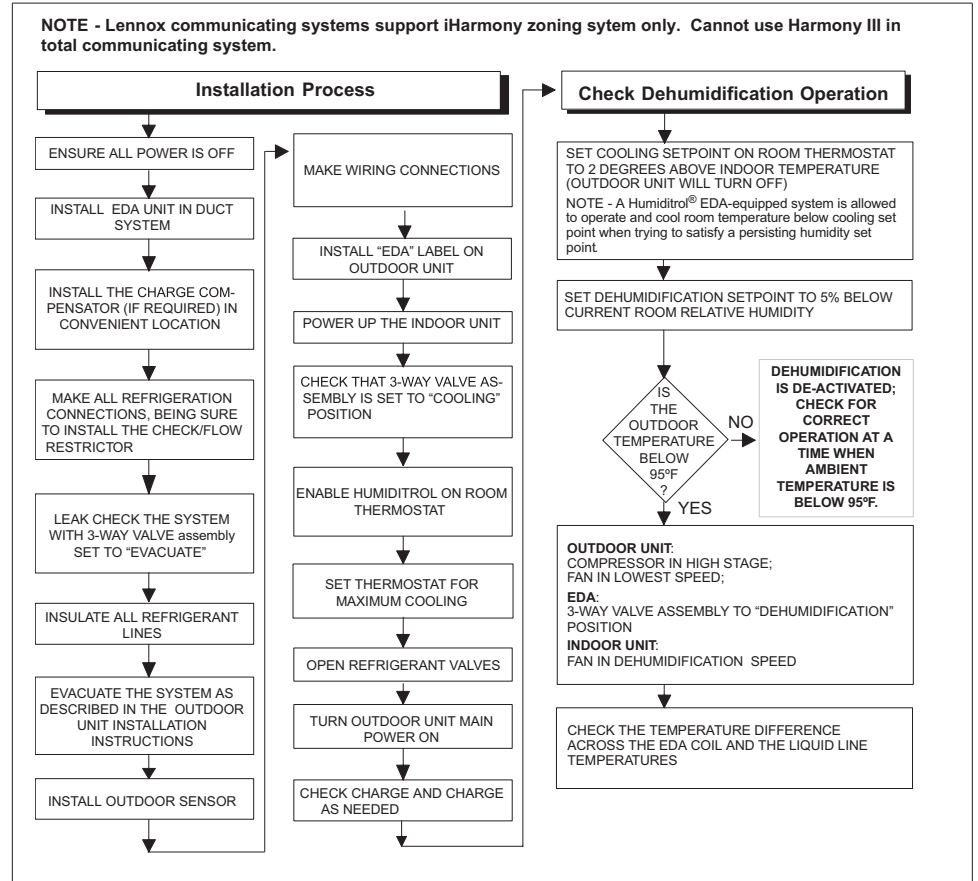

**Figure 16. Humiditrol Installation and Checkout Flow Chart**

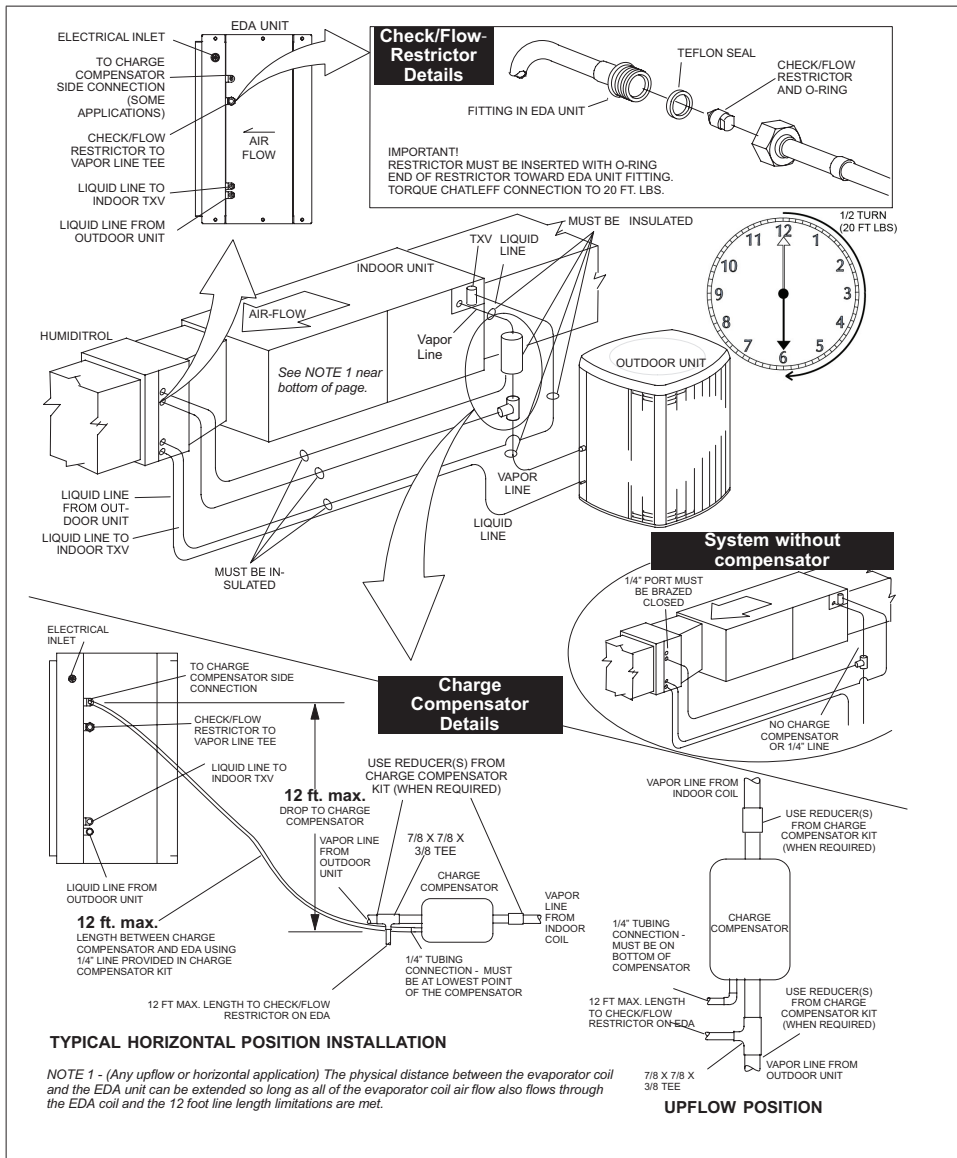

Figure 17. Typical Installation (Horizontal Air Handler Shown)

## 2.4. Leak Testing, Evacuating, Charging

# IMPORTANT

The 3-way diverting valve actuator shaft pinch bolt (see "Figure 19. Setting 3-Way Diverting Valve to Evacuate Position" on page 19) is factory set and is not to be adjusted.

# IMPORTANT

Prior to starting the outdoor unit for charging, be sure the 3-way valve is energized and in the "cooling" (forward) position (see Figure 18).

### 2.4.1. 3-Way Diverting Valve Operation

**NOTE:** During system operation, the 3-way valve requires 24-volt power to drive between cooling and dehumidification.

The 3-way diverting valve is actually two valves connected by a common shaft, designed to open one valve while closing the other, and vice-versa. For evacuating (with power off), the diverting valve can be repositioned using its actuator lever, a long pinch bolt that has been factory-set to a precise point on the common shaft. Do not loosen (unscrew) the pinch bolt. Should the pinch bolt become loose, carefully follow the note in the following figure to position and tighten it.

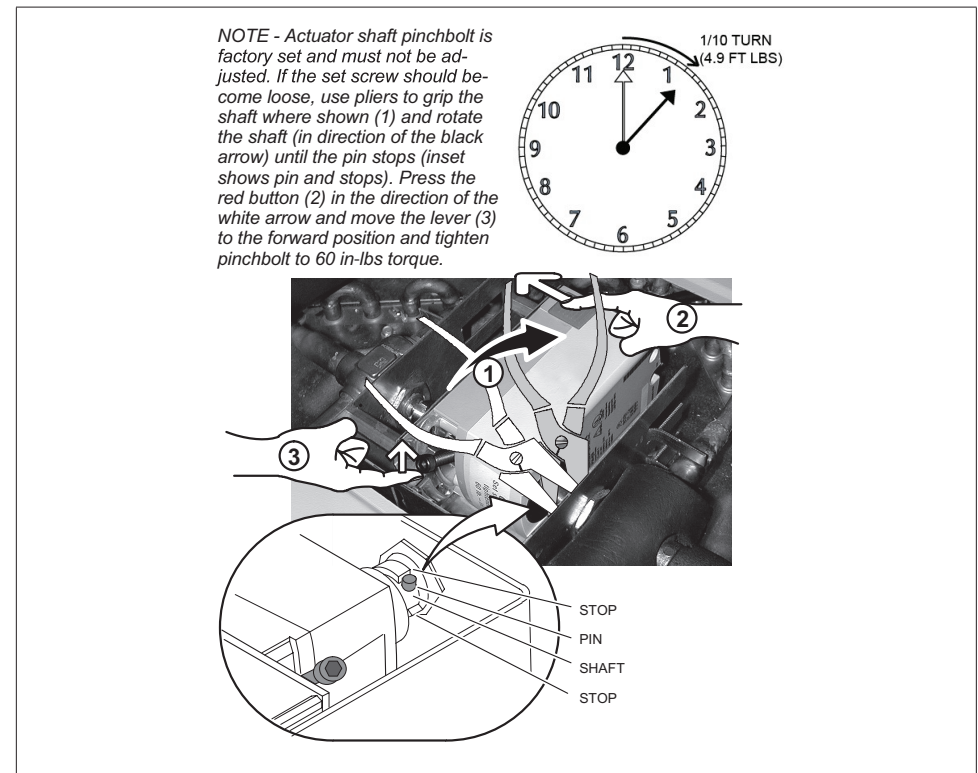

Figure 18. Re-Aligning Pinch Bolt

## 2.4.2. Leak Testing, Evacuating, Charging

1. Set the 3-way diverting valve actuator shaft to the center (evacuate) position for leak testing and evacuation as illustrated in the following figure. **IMPORTANT!** The actuator shaft must be set as described to allow the Humiditrol to evacuate more quickly.
2. Refer to instructions provided with the outdoor unit for leak testing, evacuating and charging procedures
3. Very little charge is required for the additional volume of the Humiditrol unit. When in normal cooling, the components will all be occupied by vapor that has very little weight. At most (depending on the model) an additional 1/4 pound of refrigerant may be required.
4. When shifting from dehumidify mode to cooling, or vice-versa, wait at least 10 minutes for the system to reach stable operating pressure before checking temperatures and pressures, or adjusting refrigerant charge.

**NOTE:** Prior to starting the outdoor unit for charging, set the thermostat to call for cooling (dehumidification OFF). It will take about 90 seconds for the 3-way diverting valve to energize and shift to the cooling position. To ensure that the 3-way diverting valve is energized and in the “cooling” (forward) position, observe the position of the 3-way diverting valve actuator shaft pinch bolt in the following figure; if properly shifted, the pinch bolt will be in the forward position.

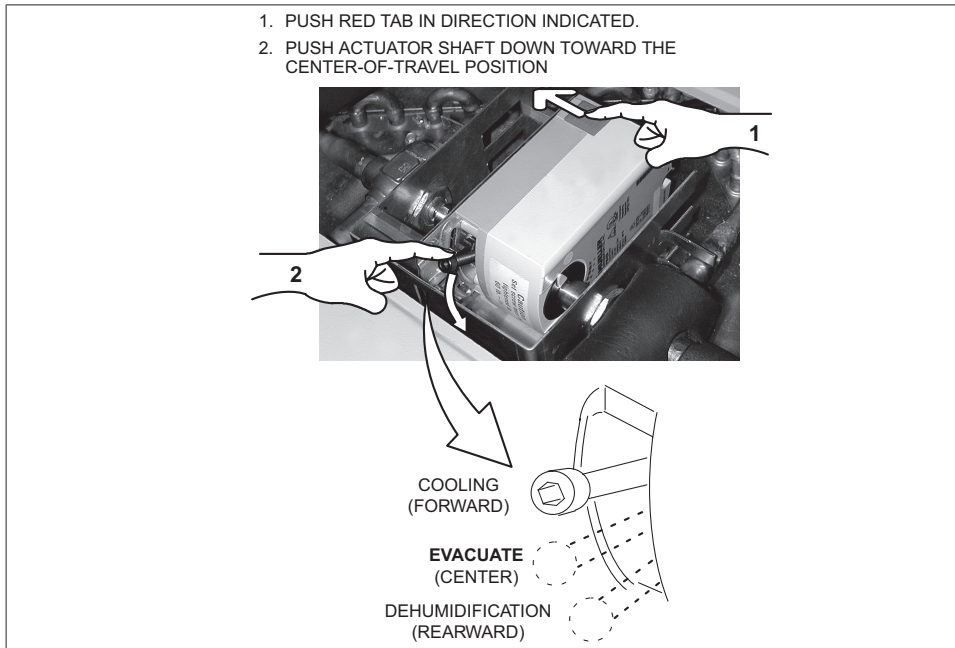

Figure 19. Setting 3-Way Diverting Valve to Evacuate Position

5. The charge must be checked with the system in cooling operation (dehumidification OFF). After testing and charging as required, set the thermostat to force a demand for dehumidification.

## 2.5. Insulating and Sealing the Unit

### IMPORTANT

All piping, metering devices, and connections must be insulated to prevent moisture damage caused by sweating.

Seal the unit so that warm air is not allowed into the cabinet. This is especially important when the unit is installed in an unconditioned area. Make sure the liquid line entry points are sealed with either refrigerant tube insulating material or with Permagum.

## 2.6. Other System Components

### 2.6.1. Blower Control

When Humiditrol units are to be applied with an indoor unit that has a variable speed motor (VSM), then refer to the indoor unit installation instruction for setting blower speed.

### 2.6.2. Thermostat and Sensor

Refer to the CS7500, Lennox® Communicating E30, M30 or S30 Thermostat Installation and Setup Guide for non-communicating installation, wiring, and setup.

**NOTE:** Lennox communicating outdoor units have an outdoor sensor installed. If these units are connected to a Lennox communicating thermostat, an optional outdoor sensor is not needed.

### IMPORTANT

Either a CS7500 or Lennox® Communicating family thermostat along with a properly connected outdoor temperature sensor are required for the Humiditrol unit to function properly.

Install the remote sensor on the outside of a northern wall of the home, away from direct sunlight or other heat sources that may affect its ability to accurately sense outdoor temperature.

## 2.7. Using Humiditrol Comfort Adjust

If Humiditrol is enabled in the installer settings, then the Humiditrol Adjustment in the User Settings affects overcooling operation (see “Table 6. Humiditrol Comfort Adjust Parameters” on page 20 and “Figure 20. Thermostat Operation with Humiditrol Enabled” on page 20 describe the parameters and illustrate Humiditrol operation under typical settings).

Overcooling ranges from 2°F below the cooling setpoint (MIN setting) down to 2°F above the heating setpoint (MAX setting). Halfway between the two settings is the MID setting.

**Table 6. Humiditrol Comfort Adjust Parameters**

| Humiditrol Comfort Adjust parameters | Indoor temperature is greater than:                     |
|--------------------------------------|---------------------------------------------------------|
| Maximum overcooling                  | 2% above heating setpoint                               |
| Midpoint overcooling                 | $\frac{\text{Heat Setpoint} + \text{Cool Setpoint}}{2}$ |
| Minimum overcooling                  | 2°F below cooling set point                             |

## 2.8. Dehumidification Requirements

Humiditrol can only operate when the thermostat is set to COOL or AUTO and meets the parameters described in the following table. If the thermostat is set to HEAT mode, no dehumidification will occur! Thermostat cycles heating ON and OFF to maintain heating setpoint.

**Table 7. Thermostat Operation with Humiditrol Enabled**

| Thermostat set to COOL mode-<br>Dehumidification will only occur if:                                                                                                                                                                                                                                                                                                        | Thermostat set to AUTO changeover-<br>Dehumidification will only occur if:                                                                                                                                                                                                                                                                                                                                                       |
|-----------------------------------------------------------------------------------------------------------------------------------------------------------------------------------------------------------------------------------------------------------------------------------------------------------------------------------------------------------------------------|----------------------------------------------------------------------------------------------------------------------------------------------------------------------------------------------------------------------------------------------------------------------------------------------------------------------------------------------------------------------------------------------------------------------------------|
| <ul style="list-style-type: none"> <li>Outdoor sensor on room thermostat installed and setup</li> <li>Dehumidification enabled on installer settings</li> <li>Dehumidification demand is present</li> <li>Cooling demand is not present</li> <li>Outdoor temperature is less than 95°F</li> <li>Indoor temperature is not cooler than 65°F</li> </ul>                       | <ul style="list-style-type: none"> <li>Outdoor sensor on room thermostat installed and setup</li> <li>Dehumidification enabled on installer settings</li> <li>Dehumidification demand is present</li> <li>Cooling demand is not present</li> <li>Outdoor temperature is less than 95°F</li> <li>Indoor temperature is not cooler than 65°F</li> <li>Indoor temperature is not cooler than 2°F above heating setpoint.</li> </ul> |
| <p>If the conditions above are met, 24VAC is removed from the Humiditrol "D" terminal and cooling begins (Indoor variable speed motor runs at dehumidification speed and outdoor unit begins the cooling cycle). Cooling calls have priority over Humiditrol calls. Humiditrol mode overcooling is user adjustable and is described in Using Humiditrol Comfort Adjust.</p> | <p>In this case, 24VAC is removed from the Humiditrol "D" terminal and cooling begins (Indoor variable speed motor runs at dehumidification speed and outdoor unit begins the cooling cycle). Cooling calls have priority over Humiditrol calls. Humiditrol mode overcooling is user adjustable and is described in Using Humiditrol Comfort Adjust.</p>                                                                         |
| <p>Humiditrol mode overcooling is user adjustable and is described in Using Humiditrol Comfort Adjust.</p>                                                                                                                                                                                                                                                                  |                                                                                                                                                                                                                                                                                                                                                                                                                                  |

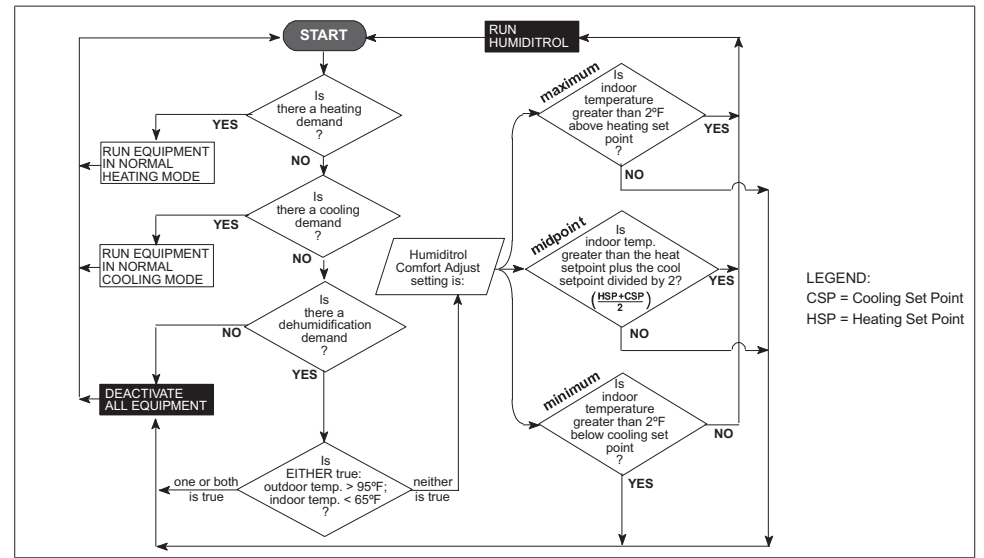
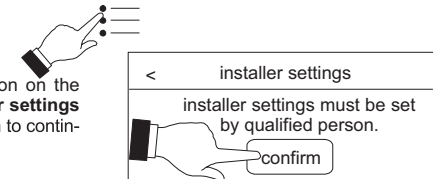

**Figure 20. Thermostat Operation with Humiditrol Enabled**

## 3. ENABLING THERMOSTATS FOR HUMIDITROL

### 3.1. CS7500 Residential Thermostat

- 1 . Touch **menu** option from the home screen.
- 2 . Touch and hold the **settings** option on the menu. This will display the **installer settings** confirmation screen. Touch **confirm** to continue.



A selection option under Installer settings > Humidity settings > Dehumidify > Dehumidify mode must be enabled before the user will have control over the humidity. The mode selected determines how the user can adjust the relative humidity (RH). The installer settings include:

- 1 . **NORMAL**
- 2 . **MAX**
- 3 . **AUXILIARY DEHUMIDIFIER**
- 4 . **HUMIDITROL**
- 5 . **OFF**

*NOTE - Humiditrol operation requires use of an outdoor sensor. If sensor is not connected enable plus Humiditrol selected. "OUTDOOR SENSOR REQUIRED" is displayed in the information display.*

#### Installing Outdoor Sensor

Install the optional (purchase separately) outdoor sensor on a northern wall of the home, away from direct sunlight or other heat sources that may affect its sensitivity.

*NOTE - The outdoor sensor uses standard thermostat wiring; it may be wired using two wires of a multi-wire cable with a wire run not to exceed 300 feet or 100 meters.*

- 1 . Connect outdoor sensor to terminals **Tc** and **To** on thermostat.
- 2 . Outdoor sensor also has to be enabled under **menu > settings > outdoor sensor = yes or no**.

**Figure 21. CS7500 Thermostat—Add and Adjust Humiditrol**

### 3.2. Lennox® Communicating E30 and S30 Thermostats

The thermostat must be configured to properly operate the Humiditrol as follows:

1. Touch the menu option in the upper-right hand corner.
2. Touch the settings icon
3. From the menu along the left side of the screen touch the **advanced settings** option.
4. Touch view dealer control center.
5. Warning message will appear, read and touch **proceed**.
6. From the dealer control center screen, touch **equipment**.
7. From the menu along the left side of the screen touch **add/remove equipment**.
8. Touch **Humiditrol** under the *Dehumidifier* option. A check mark will indicated it has been selected.
9. Go to Equipment > Smart Hub and go down the list until you reach Humiditrol Comfort Adjust.

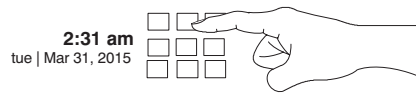

Options are Maximum Overcooling, Midpoint Overcooling and Minimum Overcooling. Default is Maximum Overcooling.

- **Maximum Overcooling:** Indoor temperature > (greater than) 2°F above heating setpoint.
- **Midpoint Overcooling:** Indoor temperature > (greater than) HEAT setpoint + COOL setpoint / 2.
- **Minimum Overcooling:** Indoor temperature > (greater than) 2°F below cooling setpoint.

Maximum allowed set point for humidification. Range is 15 to 45%. Default is 45%. Adjustments

Figure 22. E30 and S30 Thermostats—Add and Adjust Humiditrol

### 3.3. Lennox® Communicating M30 Thermostat

The thermostat must be configured to properly operate the Humiditrol as follows:

1. Touch the menu option in the upper-right hand corner.
2. Touch the settings icon
3. From the menu touch the **advanced settings** option.
4. Touch **humidity** option. Under **Humidity Control**, select **dehumidify** to enable dehumidification. By default it is **disabled**.
5. There are four setting options which are Normal, Max, Humiditrol\* and Aux Dehumidifier (requires hardware accessory installed). Slide bar adjust with a range of 40% to 60% RH.
6. For further details concerning the normal or max setting and normal and max dew point control, refer to the Lennox® Communicating M30 Installation and Setup Guide.

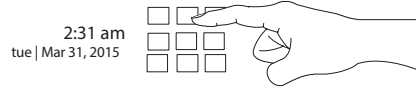

Figure 23. M30 Thermostat—Add and Adjust Humiditrol

## 4. MODES OF OPERATION

### 4.1. Dehumidification Mode (Cooling ON)

If the room thermostat's cooling demand has been satisfied but the dehumidification setting has not been satisfied, the unit continues to run in dehumidification mode. The room thermostat sends a signal to the Humiditrol unit's 3-way diverting valve assembly to begin operating in the dehumidification mode.

Figure 24 shows refrigerant flowing from the outdoor unit, entering the Humiditrol, passing through the first 3-way diverting valve, then entering the Humiditrol coil. The heat from the warm refrigerant is transferred into the indoor air stream. The refrigerant exits the coil through the second 3-way diverting valve and into the indoor coil expansion valve.

During dehumidification, the indoor air blower (and outdoor fan, if an outdoor relay is used) operates at a lower air volume. The cool, dehumidified air leaving the indoor coil is warmed as it passes over the Humiditrol coil. Air temperature rise across the Humiditrol coil can be from 10° to 25°F, depending on the operating ambient and air-conditioned space conditions.

The warm vapor-liquid-refrigerant mixture entering the Humiditrol unit from the outdoor unit will be sub-cooled in the Humiditrol unit and enter the expansion valve at a lower than normal temperature. Liquid temperatures can be in the 65° to 70°F range, with a 10° to 40°F temperature change across the Humiditrol.

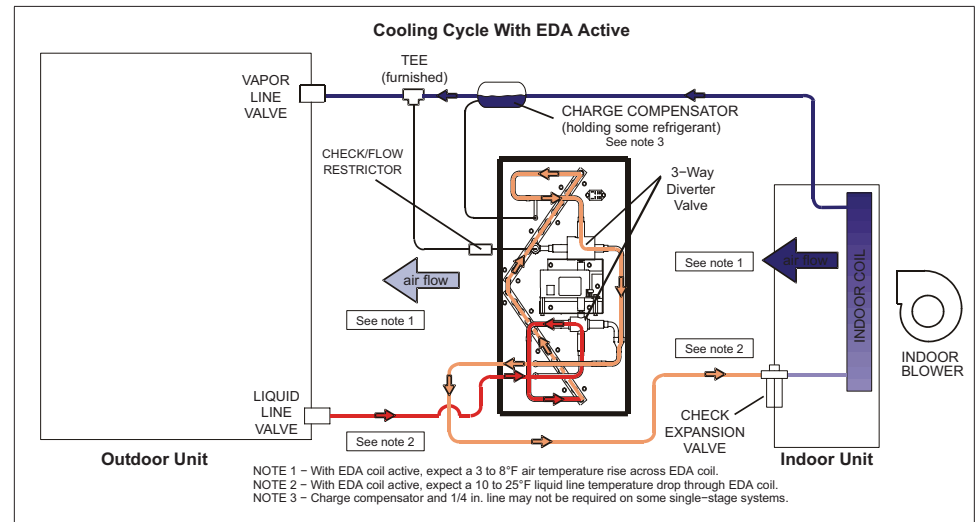
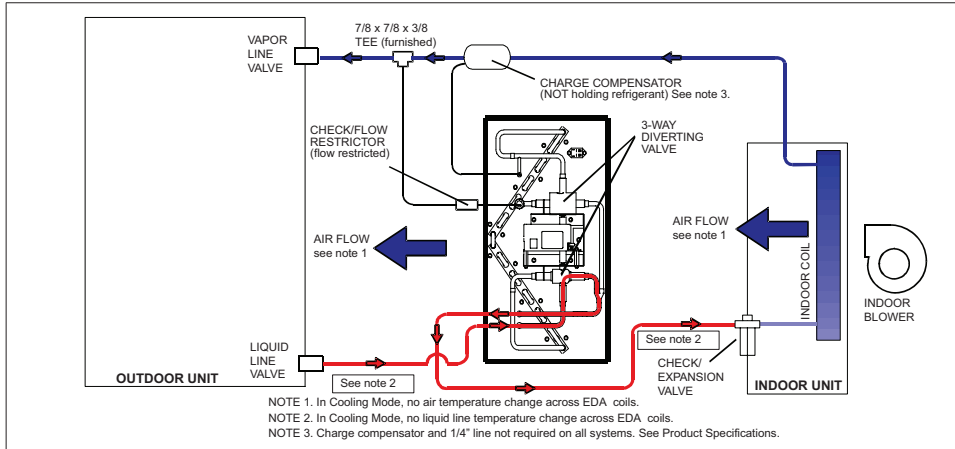

Figure 24. Dehumidification Cycle with Humiditrol Coil Active (Model EDA-036C Shown)

## 4.2. Cooling Mode (Dehumidification OFF)

The following figure illustrates refrigerant flow in cooling mode (dehumidification mode OFF). The liquid refrigerant from the outdoor unit enters the Humiditrol module. Since there is no demand for dehumidification, the 3-way diverting valve assembly directs the flow back out of the Humiditrol module to the indoor unit expansion valve.



**Figure 25. Cooling Cycle with Humiditrol Coil Inactive (Model EDA-036C Shown)**

## 4.3. Heating Mode (Heat Pump Applications)

The following figure illustrates refrigerant flow in the heating mode. In heat pump application heating mode, a system that includes an Humiditrol unit will operate as a conventional heat pump. The Humiditrol unit does not operate in this mode.

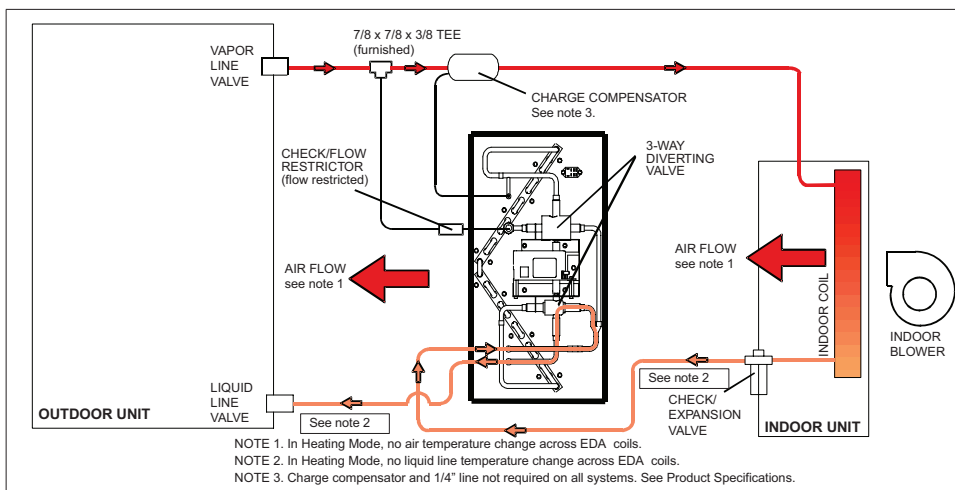

**Figure 26. Heat Pump Heating Cycle with Humiditrol Coil Inactive (Model EDA-036C Shown)**

## 5. AIR RESISTANCE

The following table shows air volume and total air resistance for the available Humiditrol models.

**Table 8. Air Resistance**

| Model No. | Air Volume |      | Total Air Resistance |    |
|-----------|------------|------|----------------------|----|
|           | cfm        | L/s  | in. w.g.             | Pa |
| EDA-024B  | 400        | 190  | 0.05                 | 12 |
|           | 600        | 285  | 0.10                 | 25 |
|           | 800        | 380  | 0.15                 | 37 |
|           | 1000       | 470  | 0.22                 | 55 |
| EDA-036C  | 600        | 285  | 0.05                 | 12 |
|           | 800        | 380  | 0.08                 | 20 |
|           | 1000       | 470  | 0.11                 | 27 |
|           | 1200       | 565  | 0.15                 | 37 |
|           | 1400       | 660  | 0.20                 | 50 |
| EDA-060D  | 1000       | 470  | 0.05                 | 12 |
|           | 1200       | 565  | 0.06                 | 15 |
|           | 1400       | 660  | 0.08                 | 20 |
|           | 1600       | 755  | 0.10                 | 25 |
|           | 1800       | 850  | 0.11                 | 27 |
|           | 2000       | 945  | 0.13                 | 32 |
|           | 2200       | 1040 | 0.15                 | 37 |

## 6. THERMOSTAT DEMAND SIGNAL

| Table 9. Demand Signals - Humiditrol               |      |                   |      |    |    |                   |        |                 |                        |                                                                                                                                                                                                                                                                                                          |
|----------------------------------------------------|------|-------------------|------|----|----|-------------------|--------|-----------------|------------------------|----------------------------------------------------------------------------------------------------------------------------------------------------------------------------------------------------------------------------------------------------------------------------------------------------------|
| Operating Sequence                                 |      | System Demand     |      |    |    |                   |        | System Response |                        |                                                                                                                                                                                                                                                                                                          |
| System Type                                        | Step | Thermostat Demand |      |    |    | Relative Humidity |        | Compr           | Blower CFM<br>(Cool) % | Comments                                                                                                                                                                                                                                                                                                 |
|                                                    |      | Y1                | Y2   | O  | G  | Status            | D      |                 |                        |                                                                                                                                                                                                                                                                                                          |
| <b>Cooling Demand - No Dehumidification Demand</b> |      |                   |      |    |    |                   |        |                 |                        |                                                                                                                                                                                                                                                                                                          |
| Single-stage outdoor unit                          | 1    | ON                | (na) | ON | ON | Acceptable        | 24 VAC | High            | 100                    | Compressor and indoor blower follow thermostat demand.                                                                                                                                                                                                                                                   |
| Two-stage outdoor unit Y1                          | 1    | ON                | -    | ON | ON | Acceptable        | 24 VAC | Low             | 70                     |                                                                                                                                                                                                                                                                                                          |
| Two-stage outdoor unit Y2                          | 2    | ON                | ON   | ON | ON | Acceptable        | 24 VAC | High            | 100                    |                                                                                                                                                                                                                                                                                                          |
| <b>Cooling Demand - Dehumidification Demand</b>    |      |                   |      |    |    |                   |        |                 |                        |                                                                                                                                                                                                                                                                                                          |
| Single-stage outdoor unit                          | 1    | ON                | (na) | ON | ON | Demand            | 24 VAC | High            | 100                    | Cooling operation has priority.                                                                                                                                                                                                                                                                          |
| Two-stage outdoor unit Y1                          | 1    | ON                | -    | ON | ON | Demand            | 24 VAC | Low             | 70                     |                                                                                                                                                                                                                                                                                                          |
| Two-stage outdoor unit Y2                          | 2    | ON                | ON   | ON | ON | Demand            | 24 VAC | High            | 100                    |                                                                                                                                                                                                                                                                                                          |
| <b>No Cooling Demand - Dehumidification Demand</b> |      |                   |      |    |    |                   |        |                 |                        |                                                                                                                                                                                                                                                                                                          |
| Single-stage outdoor unit                          | 1    | ON                | (na) | ON | ON | Demand            | 0 VAC  | High            | 60 - 82*               | A Humiditrol                                                                                                                                                                                                                                                                                             |
| Two-stage outdoor unit Y2                          | 2    | ON                | ON   | ON | ON | Demand            | 0 VAC  | High            | 60 - 82*               | Humiditrol equipped system is allowed to operate and cool room temperature below set point when trying to satisfy a persisting humidity set point (see User Humiditrol Adjust on Page 9); it is not allowed to operate at all when outdoor temperature is >95°F or when the indoor temperature is <65°F. |

**NOTE:** \* Blower CFM speed (percentage) will vary depending on selected indoor equipment (furnace, coil blower, etc.).

## 7. CHECKLIST

**Table 10. Checklist**

| Y”                                                                                                       | Checkpoint                                         | What to Check                  | Action                                                                                                                                                                                        |
|----------------------------------------------------------------------------------------------------------|----------------------------------------------------|--------------------------------|-----------------------------------------------------------------------------------------------------------------------------------------------------------------------------------------------|
|                                                                                                          | Outdoor Temperature Sensor                         | Wiring                         | Confirm outdoor temperature sensor is connected (connects directly to CS7500; in communicating systems, sensor is in outdoor unit and must be connected to indoor unit (see wiring diagrams). |
|                                                                                                          | CS7500                                             | Humiditrol Installer Settings  | Confirm HUMIDITROL is enabled (see “Figure 21. CS7500 Thermostat—Add and Adjust Humiditrol” on page 20).                                                                                      |
|                                                                                                          |                                                    | Humiditrol User Settings       | Confirm HUMIDITROL - Dehumidify - ON is selected (see “Figure 21. CS7500 Thermostat—Add and Adjust Humiditrol” on page 20).                                                                   |
|                                                                                                          |                                                    |                                | Confirm Relative Humidity setting (see “Figure 21. CS7500 Thermostat—Add and Adjust Humiditrol” on page 20).                                                                                  |
|                                                                                                          | Lennox® Communicating E30, M30 and S30 Thermostats | Humiditrol Installer Settings  | Confirm HUMIDITROL is installed and adjusted.                                                                                                                                                 |
|                                                                                                          | Indoor Unit                                        | Variable-Speed Blower Settings | Confirm Settings for “D”: CFM = 60% to 82% of second-stage cool.                                                                                                                              |
|                                                                                                          | Insulation                                         | Charge Compensator             | Confirm insulation is properly installed.                                                                                                                                                     |
|                                                                                                          | Insulation                                         | Liquid Line                    |                                                                                                                                                                                               |
|                                                                                                          | Insulation                                         | Vent Line to Suction Line      |                                                                                                                                                                                               |
|                                                                                                          | Charge Compensator                                 | 1/4” Line                      | Confirm 1/4” port oriented downward to lowest point                                                                                                                                           |
|                                                                                                          | Check/Flow Restrictor                              | 3/8” Line                      | Confirm restrictor installed/oriented properly.                                                                                                                                               |
|                                                                                                          | System Charge                                      | Refrigerant                    | With unit running in cooling mode, check and confirm system is properly charged (see outdoor unit installation instructions).                                                                 |
|                                                                                                          | Outdoor Unit                                       | Fan Relay                      | If non-communicating outdoor unit with variable speed outdoor fan. Confirm relay is installed properly.                                                                                       |
|                                                                                                          | Outdoor Unit                                       | EDA Label                      | Confirm label is installed in prominent location and will be easily visible during servicing.                                                                                                 |
| <b>NOTE:</b> System will NOT operate in dehumidification mode with outdoor temperature at or above 95°F. |                                                    |                                |                                                                                                                                                                                               |
|                                                                                                          | Operational Status                                 | Dehumidification Mode          | Record supply air temperature and confirm that temperature is higher than in cooling mode.                                                                                                    |
|                                                                                                          | Operational Status                                 | Dehumidification Mode          | On units with variable speed outdoor fan, check that fan operates at approximately 250 RPM (lowest speed).                                                                                    |