



**SUBMITTAL DATA – Multi-Position  
AHU MLB048S4S-2P – MMA048S4-1P**  
SINGLE ZONE MINI-SPLIT HEAT PUMP

**Job:** \_\_\_\_\_  
**Location:** \_\_\_\_\_  
**Schedule No.:** \_\_\_\_\_  
**System Designation:** \_\_\_\_\_

**Engineer:** \_\_\_\_\_  
**Architect:** \_\_\_\_\_  
**Date:** \_\_\_\_\_  
**For:**  Reference  Approval  Review  Construction

**FEATURES**

**Outdoor Unit: MLB048S4S-2P**



- Low Ambient Heating/Cooling
- DC Inverter Control
- Compressor Overcurrent Protection
- Base Heater
- Defrost Control

**Indoor Unit: MMA048SM4-1P**



- Constant torque blower motor
- Multi-position cabinet (upflow, downflow, horizontal)
- Completely insulated with foil faced fiberglass insulation
- Low leakage (less than 2%) cabinet
- Furnished Wired Programmable Controller and Wireless Remote Controller

**PIPING**

**Line Set and Elevation Guidelines**

Maximum Line Set Length ft. (m)	213 ft. (65 m)
Maximum Elevation - Outdoor Unit Below/Above Indoor Unit ft. (m)	98 ft. (30 m)
Liquid Line Set Diameter (in.)	3/8
Gas Line Set Diameter (in.)	5/8
Pre-Charged (ft.)	25 ft.
Additional Charge of Refrigerant (oz/ft.)	0.32

**PRODUCT WARRANTY**

Compressor – Twelve year limited warranty\*  
 All other covered components - Twelve year limited warranty\*  
 \*Product registration required

**OPTIONAL ACCESSORIES**

Hail Guard Set (M9GARD21Q-1/24M83)  
 Wired Non-PGM Controller (M0STAT120L-1)  
 M30 Smart Wi-Fi Thermostat (M0STAT64Q-2)



NOTE – Due to Lennox' ongoing commitment to quality, Specifications, Ratings, and Dimensions are subject to change without notice and without incurring liability. Improper installation, adjustment, alteration, service or maintenance can cause property damage or personal injury. Installation and service must be performed by a qualified installer and servicing agency.



**SUBMITTAL DATA – Multi-Position**  
**AHU MLB048S4S-2P – MMA048S4-1P**  
 SINGLE ZONE MINI-SPLIT HEAT PUMP

**OUTDOOR SPECIFICATIONS**

PERFORMANCE	
Cooling Capacity (Btu/h) <sup>1</sup>	47,000
EER2	7.8
SEER2	14.6
Heating Capacity (Btu/h) <sup>1</sup>	48,000
HSPF2	8.9
Outdoor Fan Total Air Volume (CFM)	4,470
Ambient Temperature Operating Range	
Cooling	-22°F - 122°F
Heating	-22°F - 86°F
ELECTRICAL DATA	
Power Supply (V/Hz/Φ)	208-230/60/1
Minimum Circuit Ampacity (A)	36.3
Maximum Overcurrent Protection (A)	50
Outdoor Fan Motor RLA (A)	2 (0.39)
Compressor RLA (A)	
No. of Compressors	2

GENERAL DATA	
Connection Ratio (%)	100%
Max. # of Indoor Units	1 unit
Sound Data (dBA) - Cooling/Heating	65/65
Refrigerant type	R-410A
Factory refrigerant charge	16 lbs. 0 oz.

DIMENSIONS		
Unit Dimensions (in)	Height	52-1/2
	Width	37-1/2
	Depth	15-7/8
Shipping Weight (lb)		256
Net Weight (lb)		228

**NOTES**

1. Cooling and Heating Capacity data is rated at the following conditions:  
 Cooling: 80°FDB / 67°FWB Indoor, 95°FDB Outdoor  
 Heating: 70°FDB Indoor, 47°FDB / 43°FWB Outdoor

**INDOOR SPECIFICATIONS**

PERFORMANCE		
Airflow (CFM)	High	1282
	Medium	1094
	Low	906
External Static Pressure (in. w.g.)		0 - 0.80
Sound Pressure (dBA)	High	53.5
	Medium	47
	Low	43.5
ELECTRICAL DATA		
Power Supply (V/Hz/Φ)	208/230V 60Hz 1Ph	
Maximum Overcurrent Protection (MOCP)		15
Minimum Circuit Ampacity (MCA)		7.5

DIMENSIONS		
Unit Dimensions (in)	Height	I J
	Width	F -1/2
	Depth	G
Shipping Weight (lb)		156

PIPING	
Liquid/Gas O.D. Flare (in.)	3/8 , 5/8
Drain Connection O.D. (in.)	3/4

FILTERS	
Size of filter - in.	19-1/2 x 20 x 1
Optional Electric Heat	Electric Heat - Please see EHB
Electric Heat Net Weight - lbs.	15

**INDOOR DIMENSIONAL DRAWINGS - INCHES (MM)**

Model No.	018 / 024		036 / 048		060	
	in.	mm	in.	mm	in.	mm
A (Height)	45	1143	49	1245	53	1346
B Width)	17-1/2	445	21-1/4	540	24-1/2	622
C	15-5/8	397	19-1/8	486	22-5/8	575
D	15-1/8	384	18-5/8	473	22-1/8	562
E	1-1/4	32	1-1/4	32	1-1/8	28
F	1-1/2	38	1-5/8	41	1-5/8	41
G	5/8	16	5/8	16	3/4	19

NOTE – Due to Lennox' ongoing commitment to quality, Specifications, Ratings, and Dimensions are subject to change without notice and without incurring liability. Improper installation, adjustment, alteration, service or maintenance can cause property damage or personal injury. Installation and service must be performed by a qualified installer and servicing agency.



SUBMITTAL DATA – **Multi-Position**  
**AHU MLB048S4S-2P – MMA048S4-1P**  
SINGLE ZONE MINI-SPLIT HEAT PUMP

**OUTDOOR DIMENSIONAL DRAWINGS - INCHES (MM)**

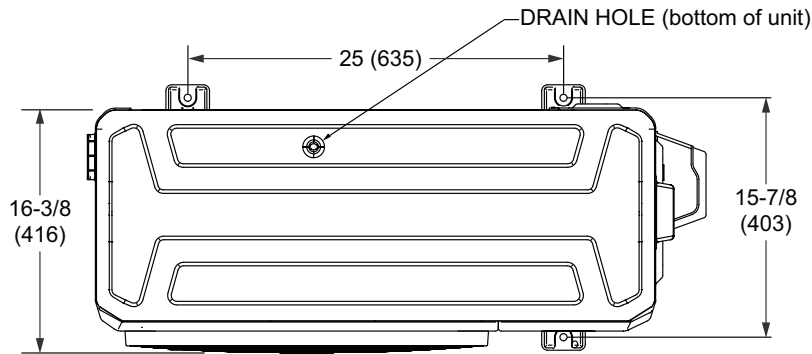

**TOP VIEW**

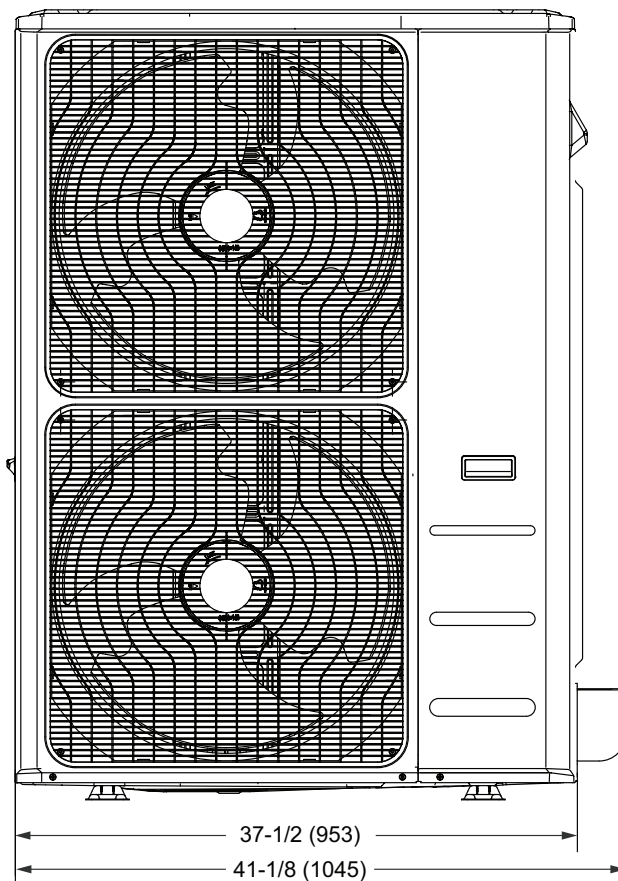

**FRONT VIEW**

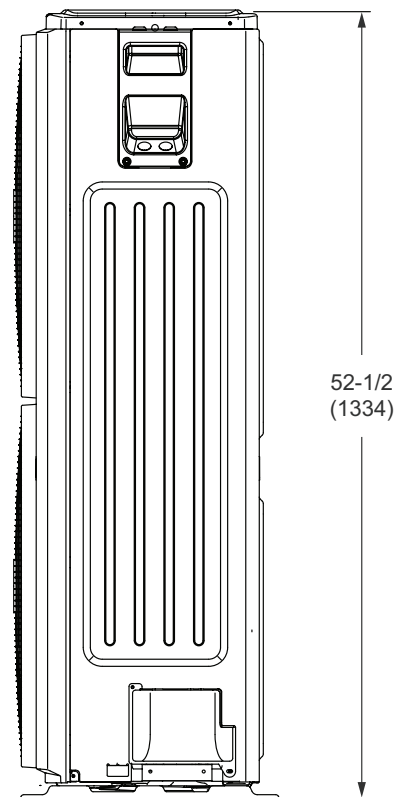

**SIDE VIEW**

NOTE – Due to Lennox' ongoing commitment to quality, Specifications, Ratings, and Dimensions are subject to change without notice and without incurring liability. Improper installation, adjustment, alteration, service or maintenance can cause property damage or personal injury. Installation and service must be performed by a qualified installer and servicing agency.



SUBMITTAL DATA – **Multi-Position**  
**AHU MLB048S4S-2P – MMA048S4-1P**  
 SINGLE ZONE MINI-SPLIT HEAT PUMP

**INDOOR DIMENSIONAL DRAWINGS - INCHES (MM)**

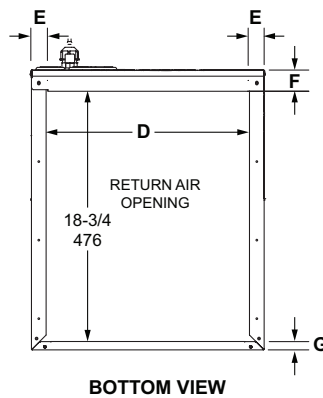
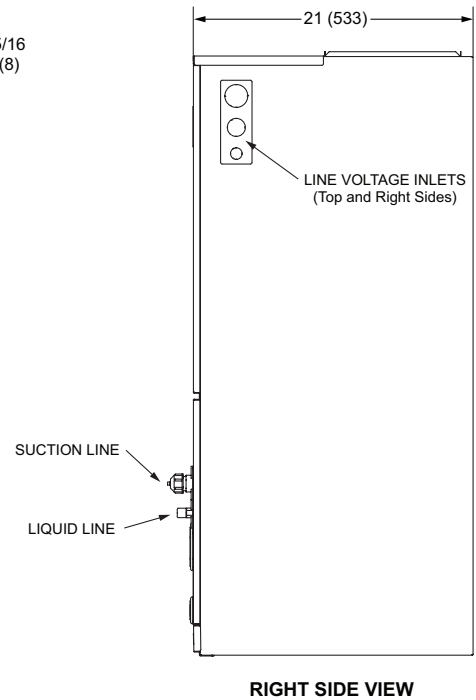
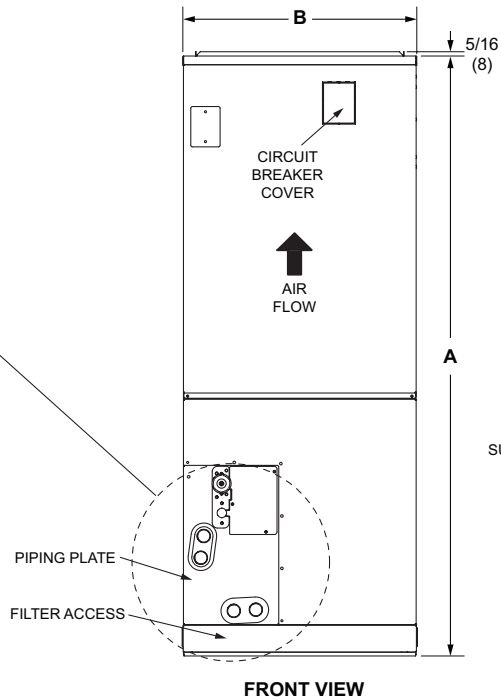
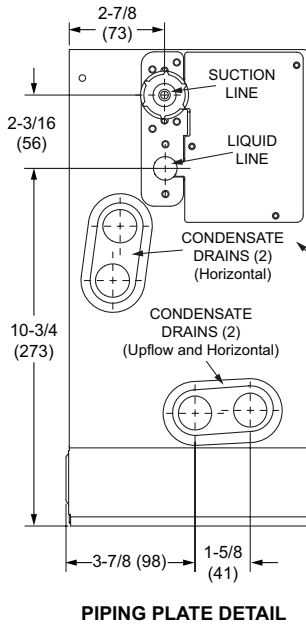
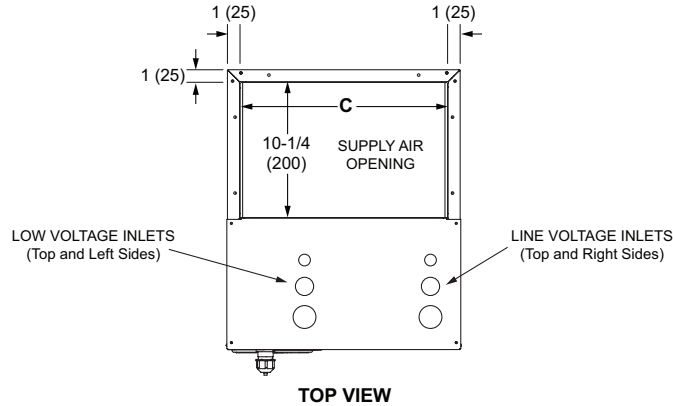

NOTE – Due to Lennox' ongoing commitment to quality, Specifications, Ratings, and Dimensions are subject to change without notice and without incurring liability. Improper installation, adjustment, alteration, service or maintenance can cause property damage or personal injury. Installation and service must be performed by a qualified installer and servicing agency.  
 496006 (202407) ©2024 Lennox Industries, Inc.