

UNIT INFORMATION

Corp. 1806-L1
05/2020

LGH/LCH

35, 40, 45, 50 TON
(123, 140.7, 158.3, 175.9 kW)

Service Literature

LGH/LCH SERIES

The LGH/LCH high and standard efficiency 35, 40, 45 and 50 ton (123, 140.7, 158.3 and 175.9 kW) units, are configured to order units (CTO) with a wide selection of factory installed options. The LGH/LCH rooftop units are available in 500,000 Btuh or 800,000 Btuh (146.5 kW or 234.4kW) heating inputs. Gas heat sections are designed with aluminumized or stainless steel tube heat exchangers. LGH and LCH units are equipped with the same cooling sections and cooling components. The LGH/LCH units utilize four scroll compressors with each compressor equipped with a crankcase heater.

LGH/LCH units are designed for R-410A (high efficiency). Service equipment for R-410A units must be rated for R-410A refrigerant.

Optional electric heat is factory installed in LCH units. Electric heat operates in single or multiple stages depending on the kW input size. 30kW through 90kW heat sections are available for the LCH units in all voltages G, J and Y while 105kW through 180kW heat sections are available for LCH G and J voltage units only.

The LGH/LCH units are designed to accept any of several different energy management thermostat control systems with minimum field wiring. Factory or field provided control options connect to the unit with jack plugs. When "plugged in" the controls become an integral part of the unit wiring.

If the unit must be lifted for service, rig unit by attaching eight cables to the holes located in the unit base rail (two holes at each corner and center of frame). Refer to the installation instructions for the proper rigging technique.

Information contained in this manual is intended for use by qualified service technicians only. All specifications are subject to change. Procedures outlined in this manual are presented as a recommendation only and do not supersede or replace local or state codes.

⚠ IMPORTANT

Improper installation, adjustment, alteration, service or maintenance can cause property damage, personal injury or loss of life. Installation and service must be performed by a qualified installer or service agency.

⚠ WARNING



Electric shock hazard. Can cause injury or death. Before attempting to perform any service or maintenance, turn the electrical power to unit OFF at disconnect switch(es). Unit may have multiple power supplies.

⚠ CAUTION

Danger of sharp metallic edges. Can cause injury. Take care when servicing unit to avoid accidental contact with sharp edges.

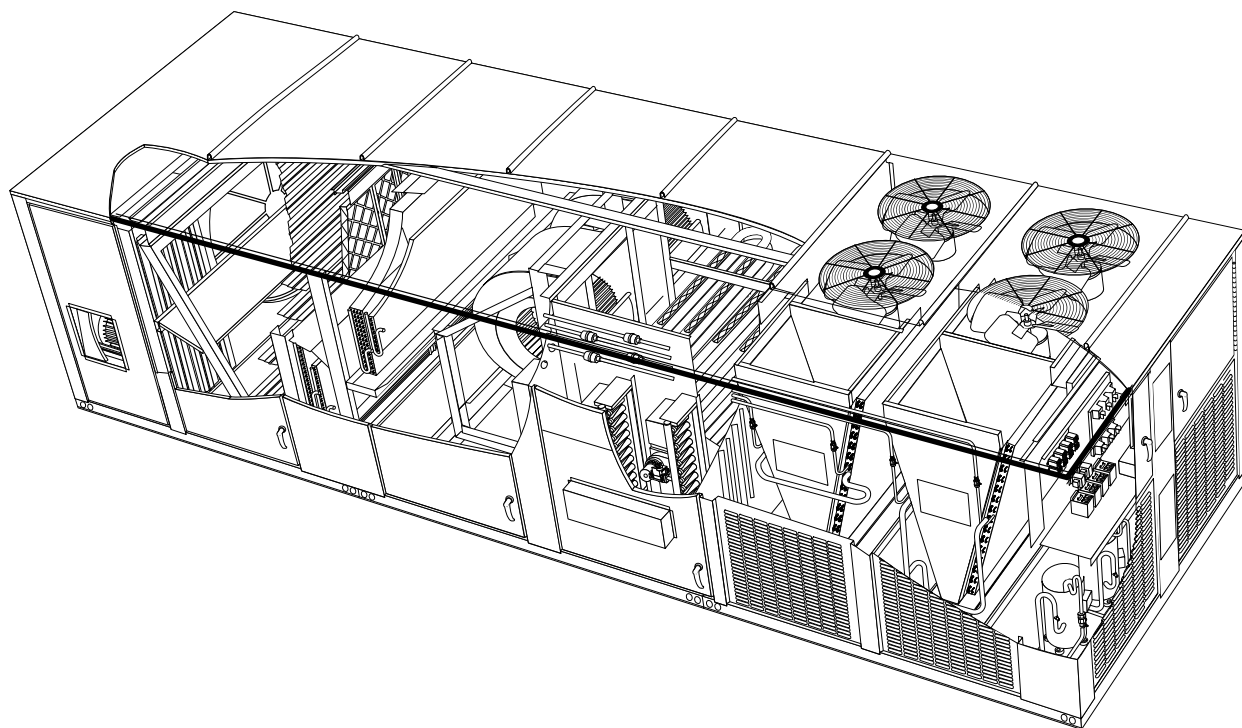

TABLE OF CONTENTS

<p>Introduction Page 1</p> <p>Options / Accessories Page 3</p> <p>Specifications Page 5</p> <p>Blower Data Page 13</p> <p>Blower Drive Kits Page 21</p> <p>Energy Recovery Wheel Specifications .. Page 22</p> <p>Electrical Data Page 23</p> <p>Manufacturer's Drive Numbers Page 43</p> <p>Parts Arrangement Page 44</p> <p>I- UNIT COMPONENTS Page 46</p> <p> Control Box Components Page 46</p> <p> Cooling Components Page 52</p> <p> Blower Compartment Page 55</p> <p> Gas Heat Components Page 59</p> <p> Electric Heat Components Page 64</p> <p>II-PLACEMENT AND INSTALLATION Page 65</p> <p>III- START UP Page 65</p> <p> Preliminary Checks Page 66</p> <p> Cooling Start Up Page 66</p> <p> Charging Page 67</p> <p> Heating Start Up Page 68</p> <p> Safety or Emergency Shutdown Page 69</p> <p>IV-SYSTEM SERVICE CHECKS Page 69</p> <p> Heating System Service Checks Page 69</p> <p> Cooling System Service Checks Page 71</p>	<p>V-MAINTENANCE Page 71</p> <p> Filters Page 71</p> <p> Lubrication Page 72</p> <p> Supply Air Blower Wheel Page 73</p> <p> Evaporator and Condenser Coil Page 73</p> <p> Electrical Page 73</p> <p> Combustion Air Inducer Page 73</p> <p> Burners Page 73</p> <p> Flue Box Page 73</p> <p>VI-ACCESSORIES Page 74</p> <p> Mounting Frame Page 74</p> <p> Outdoor Air Dampers Page 75</p> <p> Economizers Page 75</p> <p> Variable Frequency Drive (VAV) Page 76</p> <p> Gravity Exhaust Dampers Page 77</p> <p> Power Exhaust Fans Page 77</p> <p> Control Systems Page 79</p> <p> Smoke Detectors Page 79</p> <p> Energy Recovery Wheel Page 79</p> <p> Blower Proving Switch Page 80</p> <p> Dirty Filter Switch Page 80</p> <p> Indoor Air Quality Sensor Page 80</p> <p> Drain Pan Overflow Switch Page 80</p> <p> Humiditrol Page 80</p> <p> Modulating Gas Valve Page 83</p> <p> Outdoor Air CFM Control Page 84</p> <p> Hot Gas Bypass Page 84</p> <p>WIRING DIAGRAMS Page 86</p>
--	--

OPTIONS/ACCESSORIES			
Item		Factory	Field
COOLING SYSTEM			
Corrosion Protection - Condenser and Evaporator Coils		O	
Discharge Air Temperature Sensor (MSAV models only)		O	
Drain Pan Overflow Switch		O	
High Efficiency - R-410A (35, 40 Ton Models)		O	
Hot Gas Bypass (Not available with Humiditrol® Dehumidification Option)		O	
Standard Efficiency - R-410A (35, 40, 45, 50 Ton Models)		O	
Service Valves		O	
Spring Isolation (compressor deck)		O	
Stainless Steel Drain Pan		O	
AIR FILTERS			
MERV 8 - Two Inch		O	
MERV 8 - Four Inch		O	
MERV 13 High Efficiency - Two Inch		O	
MERV 13 High Efficiency - Four Inch		O	
Cleanable Metal Mesh - Two Inch		O	
BLOWER			
Supply Motor - 5, 7.5, 10, 15, 20, 25, 30 hp		O	
Supply VFD Blower Bypass		O	
Spring Isolation (blower frame)		O	
CABINET			
Air Flow - Vertical		O	
Air Flow - Horizontal		O	
Double Wall Construction		O	
Hinged Louvered Condenser Section Panels		O	
¹ ROOF CURBS - STANDARD			
14 in. height	E1CURB71E-1		X
24 in. height	E1CURB73E-1		X
CONTROLS			
Blower Proving Switch		O	
Commercial Controls	Prodigy® Control System - BACnet® Module - C0CTRL60AE1L	O	X
	Prodigy® Control System - LonTalk® Module - C0CTRL65FF1	O	X
	Novar® ETM-2051 Unit Controller - E0CTRL30C1	O	
	Novar® LSE Unit Controller	O	
	CPC Einstein Unit Controller	O	
	L Connection® Network Control System		X
Dirty Filter Switch		O	X
General Purpose Control Kit		E1GPBK30C1	X
Supply Static Pressure Limit Switch - Duct Mounted	C0SNSR11AE1 (Switch)		X
	C0SNSR12AE1- (Mounting Kit)		X
Smoke Detector	Return	O	
	Supply	O	
	Supply & Return	O	
ELECTRICAL			
Voltage (60HZ) - 208/230V-3 phase, 460V-3 phase or 575V-3 phase		O	
HACR Circuit Breakers - 70, 80, 90, 100, 110, 125, 150, 175, 200, 225, 250 amp		O	
Not available for units with electric heat and dual point power supply			
Disconnect Switch - 150, 250 amp		O	
Not available for units with electric heat and dual point power supply			
GFI Service Outlets	15 amp non-powered, field-wired (208/230V, 460V, 575V) LTAGFIK10/15	O	X
	15 amp factory-wired and powered (208/230V, 460V, 575V)	O	
	20 amp non-powered, field-wired (575V only) C1GFIC120FF1	O	X
Weatherproof Cover for GFI		C1GFIC199FF1	X

¹ Also available - Roof curbs for vibration isolation, seismic conditions, seismic with wind restraints. Contact your Sales Representative for additional information.

O = Configure to Order (Factory Installed).

X = Field Installed.

OPTIONS/ACCESSORIES

Item	Factory	Field
ELECTRIC HEAT (NOT AVAILABLE WITH HORIZONTAL CONFIGURED UNITS)		
35 ton units - 30-45-60-75-90 kW (all voltages)	O	
35 ton units - 105-120 kW (460V & 575V only)	O	
40 ton units - 30-45-60-75-90 kW (all voltages)	O	
40 ton units - 105-120-135-150 kW (460V & 575V only)	O	
45 ton units - 45-60-75-90 kW (all voltages)	O	
45 ton units - 105-120-135-150-165 kW (460V & 575V only)	O	
50 ton units - 45-60-75-90 kW (all voltages)	O	
50 ton units - 105-120-135-150-165-180 kW (460V & 575V only)	O	
Single-Point Power Supply	O	
HUMIDITROL® CONDENSER REHEAT (MSAV UNITS ONLY)		
Humiditrol® Dehumidification Option	O	
Humidity Sensor Kit, Remote Mounted (required)		X
Remote Sensor Wall Seal Plate		X
indoor air quality		
Sensor - Wall-mount, off-white plastic cover with LCD display	C0SNSR50AE1L	X
Sensor - Wall-mount, off-white plastic cover, no display	C0SNSR52AE1L	X
Sensor - Black plastic case with LCD display, rated for plenum mounting	C0SNSR51AE1L	X
Sensor - Wall-mount, black plastic case, no display, rated for plenum mounting	C0MISC19AE1	X
CO Sensor Duct Mounting Kit - for downflow applications	C0MISC19AE1-	X
Aspiration Box - for duct mounting non-plenum rated CO (87N53 or 77N39) sensors	C0MISC16AE1-	X
ECONOMIZER/OUTDOOR AIR/EXHAUST		
Standard Economizer (Not for Title 24)	O	
High Performance Economizer (Approved for California Title 24 Building Standards / AMCA Class 1A Certified)	O	
Economizer Controls		
Differential Sensible (factory setting)	O	
Global Control	O	
Single Enthalpy (Not for Title 24)	O	
Differential Enthalpy (Not for Title 24)	O	
Fresh Air Tempering	O	
Outdoor Air CFM Control	O	
Outdoor Air Dampers - Manual or Motorized	O	
Barometric Relief Dampers (Exhaust Hood Furnished for Field Installation)	O	
Power Exhaust (see next page for specifications)		
50% Standard Static	O	
100% Standard Static	O	
50% High Static Power Exhaust	O	
100% High Static Power Exhaust	O	
50% High Static Power Exhaust with VFD	O	
100% High Static Power Exhaust with VFD	O	
50% High Static Power Exhaust with VFD and Bypass	O	
100% High Static Power Exhaust with VFD and Bypass	O	
Power Exhaust Controls		
Damper Position Control	O	
¹ Differential Pressure Transducer	O	
Pressure Switch (order two)	C0SNSR10AE1	X
High Static Power Exhaust Options		
Spring Isolation (blower frame)	O	
Energy Recovery Wheel (not available with horizontal configured units)	O	

¹ Furnished as standard with High Static Power Exhaust with VFD.

O = Configure to Order (Factory Installed).

X = Field Installed.

SPECIFICATIONS - OPTIONAL POWER EXHAUST

Standard Static (50%)	(No.) Motor output	(1) 1 hp
	Motor rpm	1140
	(No.) Diameter - in.	(1) 26
	No. of blades	4
Standard Static (100%)	(No.) Motor output	(2) 1 hp
	Motor rpm	1140
	(No.) Diameter - in.	(2) 26
	No. of blades	4
High Static (50%)	(No.) Nominal motor output	(1) 3, 5 or 7.5 hp available See Blower Data Tables for selection
	Motor - Drive Kit	690 to 1065 rpm available See Blower Drive Kit Tables for selection
	(No.) Blower wheel nominal diameter x width	(1) 18 x 15
	(No.) Nominal motor output	(2) 3, 5 or 7.5 hp available See Blower Data Tables for selection
High Static (100%)	Motor - Drive Kit	690 to 1065 rpm available See Blower Drive Kit Tables for selection
	(No.) Blower wheel nominal diameter x width	(2) 18 x 15

SPECIFICATIONS - 35 TON STANDARD EFFICIENCY

General Data		Nominal Tonnage	35 Ton	35 Ton	
		Model No.	420S4M	420S4V	
		Efficiency Type	Standard	Standard	
		Blower Type	MSAV® (Multi-Stage Air Volume)	Variable Air Volume (VAV)	
Cooling Performance	Gross Cooling Capacity - Btuh		433,000	433,000	
	¹ Net Cooling Capacity - Btuh		410,000	410,000	
	AHRI Rated Air Flow - cfm		14,000	14,000	
	Total Unit Power - kW		41.0	41.0	
	¹ EER (Btuh/Watt)		10.0	10.0	
	² IEER (Btuh/Watt)		13.5	13.2	
	Refrigerant Type		R-410A	R-410A	
	Refrigerant Charge Furnished	Circuit 1		22 lbs. 0 oz.	22 lbs. 0 oz.
		Circuit 2		22 lbs. 0 oz.	22 lbs. 0 oz.
		Circuit 3		22 lbs. 0 oz.	22 lbs. 0 oz.
Circuit 4			22 lbs. 0 oz.	22 lbs. 0 oz.	
Refrigerant Charge Furnished with Humiditrol® Dehumidification Option	Circuit 1		27 lbs. 0 oz.	---	
	Circuit 2		27 lbs. 0 oz.	---	
	Circuit 3		22 lbs. 0 oz.	---	
	Circuit 4		22 lbs. 0 oz.	---	
Compressor Type (no.)			Scroll (4)	Scroll (4)	
Condenser Coils	Net face area - sq. ft. total		94.1	94.1	
	Tube diameter - in.		3/8	3/8	
	Number of rows		2	2	
	Fins per inch		20	20	
Condenser Fans	Motor horsepower		(6) 3/4	(6) 3/4	
	Motor rpm		1075	1075	
	Total Motor watts		4800	4800	
	Diameter - in.		(6) 24	(6) 24	
	No. of blades		4	4	
	Total Air volume - cfm		30,000	30,000	
Evaporator Coils	Net face area - sq. ft. total		37.4	37.4	
	Tube diameter - in.		3/8	3/8	
	No. of rows		4	4	
	Fins per inch		14	14	
	Drain connection - number and size		(1) 1 in. NPT coupling	(1) 1 in. NPT coupling	
Expansion device type			Balanced Port Thermostatic Expansion Valve, removeable power head		
Indoor Blower and Drive Selection	Nominal motor output		5 to 30 hp available - See Blower Data Tables for selection		
	Motor - Drive kit		510 to 1340 rpm available - See Blower Drive Kit Tables for selection	510 to 1340 rpm available - See Blower Drive Kit Tables for selection	
	Blower wheel nominal dia. x width - in.		(2) 20 x 15	(2) 20 x 15	
Filters	Type of filter		Disposable, pleated MERV 4		
	No. and size - in.		(11) 25 x 16 x 2		
Electrical characteristics			208/230V, 460V or 575V - 60 hertz - 3 phase		

NOTE - Net capacity includes evaporator blower motor heat deduction. Gross capacity does not include evaporator blower motor heat deduction.

¹ Tested at conditions included in AHRI Standard 340/360; 95°F outdoor air temperature and 80°F db/67°F wb entering evaporator air; minimum external duct static pressure.

² Integrated Energy Efficiency Ratio tested according to AHRI Standard 340/360.

SPECIFICATIONS - 35 TON HIGH EFFICIENCY

General Data		Nominal Tonnage	35 Ton	35 Ton	
		Model No.	420H4M	420H4V	
		Efficiency Type	High	High	
		Blower Type	MSAV® (Multi-Stage Air Volume)	Variable Air Volume (VAV)	
Cooling Performance	Gross Cooling Capacity - Btuh		443,000	443,000	
	¹ Net Cooling Capacity - Btuh		420,000	420,000	
	AHRI Rated Air Flow - cfm		14,000	14,000	
	Total Unit Power - kW		38.9	38.9	
	¹ EER (Btuh/Watt)		10.8	10.8	
	² IEER (Btuh/Watt)		14.5	14.0	
	Refrigerant Type		R-410A	R-410A	
	Refrigerant Charge Furnished	Circuit 1		31 lbs. 0 oz.	31 lbs. 0 oz.
		Circuit 2		31 lbs. 0 oz.	31 lbs. 0 oz.
		Circuit 3		31 lbs. 0 oz.	31 lbs. 0 oz.
Circuit 4			31 lbs. 0 oz.	31 lbs. 0 oz.	
Refrigerant Charge Furnished with Humiditrol® Dehumidification Option	Circuit 1		36 lbs. 0 oz.	---	
	Circuit 2		36 lbs. 0 oz.	---	
	Circuit 3		31 lbs. 0 oz.	---	
	Circuit 4		31 lbs. 0 oz.	---	
Compressor Type (no.)			Scroll (4)	Scroll (4)	
Condenser Coils	Net face area - sq. ft. total		111.2	111.2	
	Tube diameter - in.		3/8	3/8	
	Number of rows		3	3	
	Fins per inch		20	20	
Condenser Fans	Motor horsepower		(6) 1	(6) 1	
	Motor rpm		1140	1140	
	Total Motor watts		5000	5000	
	Diameter - in.		(6) 24	(6) 24	
	No. of blades		4	4	
	Total Air volume - cfm		35,000	35,000	
Evaporator Coils	Net face area - sq. ft. total		37.4	37.4	
	Tube diameter - in.		3/8	3/8	
	No. of rows		4	4	
	Fins per inch		14	14	
	Drain connection - number and size		(1) 1 in. NPT coupling	(1) 1 in. NPT coupling	
Expansion device type			Balanced Port Thermostatic Expansion Valve, removeable power head		
Indoor Blower and Drive Selection	Nominal motor output		5 to 30 hp available - See Blower Data Tables for selection		
	Motor - Drive kit		510 to 1340 rpm available - See Blower Drive Kit Tables for selection	510 to 1340 rpm available - See Blower Drive Kit Tables for selection	
	Blower wheel nominal dia. x width - in.		(2) 20 x 15	(2) 20 x 15	
Filters	Type of filter		Disposable, pleated MERV 4		
	No. and size - in.		(11) 25 x 16 x 2		
Electrical characteristics			208/230V, 460V or 575V - 60 hertz - 3 phase		

NOTE - Net capacity includes evaporator blower motor heat deduction. Gross capacity does not include evaporator blower motor heat deduction.

¹ Tested at conditions included in AHRI Standard 340/360; 95°F outdoor air temperature and 80°F db/67°F wb entering evaporator air; minimum external duct static pressure.

² Integrated Energy Efficiency Ratio tested according to AHRI Standard 340/360.

SPECIFICATIONS - 40 TON STANDARD EFFICIENCY

General Data		Nominal Tonnage	40 Ton	40 Ton	
		Model No.	480S4M	480S4V	
		Efficiency Type	Standard	Standard	
		Blower Type	MSAV® (Multi-Stage Air Volume)	Variable Air Volume (VAV)	
Cooling Performance	Gross Cooling Capacity - Btuh		476,000	476,000	
	¹ Net Cooling Capacity - Btuh		450,000	450,000	
	AHRI Rated Air Flow - cfm		14,800	14,800	
	Total Unit Power - kW		45.0	45	
	¹ EER (Btuh/Watt)		10.0	10.0	
	² IEER (Btuh/Watt)		13.5	13.2	
	Refrigerant Type		R-410A	R-410A	
	Refrigerant Charge Furnished	Circuit 1		22 lbs. 0 oz.	22 lbs . 0 oz.
		Circuit 2		22 lbs. 0 oz.	22 lbs . 0 oz.
		Circuit 3		22 lbs. 0 oz.	22 lbs . 0 oz.
		Circuit 4		22 lbs. 0 oz.	22 lbs . 0 oz.
Refrigerant Charge Furnished with Humiditrol® Dehumidification Option	Circuit 1		27 lbs. 0 oz.	---	
	Circuit 2		27 lbs. 0 oz.	---	
	Circuit 3		22 lbs. 0 oz.	---	
	Circuit 4		22 lbs. 0 oz.	---	
Compressor Type (no.)			Scroll (4)	Scroll (4)	
Condenser Coils	Net face area - sq. ft. total		94.1	94.1	
	Tube diameter - in.		3/8	3/8	
	Number of rows		2	2	
	Fins per inch		20	20	
Condenser Fans	Motor horsepower		(6) 3/4	(6) 3/4	
	Motor rpm		1075	1075	
	Total Motor watts		4800	4800	
	Diameter - in.		(6) 24	(6) 24	
	No. of blades		4	4	
	Total Air volume - cfm		30,000	30,000	
Evaporator Coils	Net face area - sq. ft. total		37.4	37.4	
	Tube diameter - in.		3/8	3/8	
	No. of rows		4	4	
	Fins per inch		14	14	
	Drain connection - number and size		(1) 1 in. NPT coupling	(1) 1 in. NPT coupling	
Expansion device type			Balanced Port Thermostatic Expansion Valve, removeable power head		
Indoor Blower and Drive Selection	Nominal motor output		5 to 30 hp available - See Blower Data Tables for selection		
	Motor - Drive kit		510 to 1340 rpm available - See Blower Drive Kit Tables for selection	510 to 1340 rpm available - See Blower Drive Kit Tables for selection	
	Blower wheel nominal dia. x width - in.		(2) 20 x 15	(2) 20 x 15	
Filters	Type of filter		Disposable, pleated MERV 4		
	No. and size - in.		(11) 25 x 16 x 2		
Electrical characteristics			208/230V, 460V or 575V - 60 hertz - 3 phase		

NOTE - Net capacity includes evaporator blower motor heat deduction. Gross capacity does not include evaporator blower motor heat deduction.

¹ Tested at conditions included in AHRI Standard 340/360; 95°F outdoor air temperature and 80°F db/67°F wb entering evaporator air; minimum external duct static pressure.

² Integrated Energy Efficiency Ratio tested according to AHRI Standard 340/360.

SPECIFICATIONS - 40 TON HIGH EFFICIENCY

General Data		Nominal Tonnage	40 Ton	40 Ton	
		Model No.	480H4M	480H4V	
		Efficiency Type	High	High	
		Blower Type	MSAV® (Multi-Stage Air Volume)	Variable Air Volume (VAV)	
Cooling Performance	Gross Cooling Capacity - Btuh		494,000	494,000	
	¹ Net Cooling Capacity - Btuh		470,000	470,000	
	AHRI Rated Air Flow - cfm		14,000	14,000	
	Total Unit Power - kW		43.5	43.5	
	¹ EER (Btuh/Watt)		10.8	10.8	
	² IEER (Btuh/Watt)		14.5	14.0	
	Refrigerant Type		R-410A	R-410A	
	Refrigerant Charge Furnished	Circuit 1		31 lbs. 0 oz.	31 lbs. 0 oz.
		Circuit 2		31 lbs. 0 oz.	31 lbs. 0 oz.
		Circuit 3		31 lbs. 0 oz.	31 lbs. 0 oz.
Circuit 4			31 lbs. 0 oz.	31 lbs. 0 oz.	
Refrigerant Charge Furnished with Humiditrol® Dehumidification Option	Circuit 1		36 lbs. 0 oz.	---	
	Circuit 2		36 lbs. 0 oz.	---	
	Circuit 3		31 lbs. 0 oz.	---	
	Circuit 4		31 lbs. 0 oz.	---	
Compressor Type (no.)			Scroll (4)	Scroll (4)	
Condenser Coils	Net face area - sq. ft. total		111.2	111.2	
	Tube diameter - in.		3/8	3/8	
	Number of rows		3	3	
	Fins per inch		20	20	
Condenser Fans	Motor horsepower		(6) 1	(6) 1	
	Motor rpm		1140	1140	
	Total Motor watts		5000	5000	
	Diameter - in.		(6) 24	(6) 24	
	No. of blades		4	4	
	Total Air volume - cfm		35,000	35,000	
Evaporator Coils	Net face area - sq. ft. total		37.4	37.4	
	Tube diameter - in.		3/8	3/8	
	No. of rows		4	4	
	Fins per inch		14	14	
	Drain connection - number and size		(1) 1 in. NPT coupling	(1) 1 in. NPT coupling	
Expansion device type			Balanced Port Thermostatic Expansion Valve, removeable power head		
Indoor Blower and Drive Selection	Nominal motor output		5 to 30 hp available - See Blower Data Tables for selection		
	Motor - Drive kit		510 to 1340 rpm available - See Blower Drive Kit Tables for selection	510 to 1340 rpm available - See Blower Drive Kit Tables for selection	
	Blower wheel nominal dia. x width - in.		(2) 20 x 15	(2) 20 x 15	
Filters	Type of filter		Disposable, pleated MERV 4		
	No. and size - in.		(11) 25 x 16 x 2		
Electrical characteristics			208/230V, 460V or 575V - 60 hertz - 3 phase		

NOTE - Net capacity includes evaporator blower motor heat deduction. Gross capacity does not include evaporator blower motor heat deduction.

¹ Tested at conditions included in AHRI Standard 340/360; 95°F outdoor air temperature and 80°F db/67°F wb entering evaporator air; minimum external duct static pressure.

² Integrated Energy Efficiency Ratio tested according to AHRI Standard 340/360.

SPECIFICATIONS - 45 TON STANDARD EFFICIENCY

General Data		Nominal Tonnage	45 Ton	45 Ton	
		Model No.	540S4M	540S4V	
		Efficiency Type	Standard	Standard	
		Blower Type	MSAV® (Multi-Stage Air Volume)	Variable Air Volume (VAV)	
Cooling Performance	Gross Cooling Capacity - Btuh		549,000	549,000	
	¹ Net Cooling Capacity - Btuh		520,000	520,000	
	AHRI Rated Air Flow - cfm		15,000	15,000	
	Total Unit Power - kW		52.0	52.0	
	¹ EER (Btuh/Watt)		10.0	10.0	
	² IEER (Btuh/Watt)		13.7	13.6	
	Refrigerant Type		R-410A	R-410A	
	Refrigerant Charge Furnished	Circuit 1		31 lbs. 0 oz.	31 lbs. 0 oz.
		Circuit 2		31 lbs. 0 oz.	31 lbs. 0 oz.
		Circuit 3		31 lbs. 0 oz.	31 lbs. 0 oz.
Circuit 4			31 lbs. 0 oz.	31 lbs. 0 oz.	
Refrigerant Charge Furnished with Humiditrol® Dehumidification Option	Circuit 1		36 lbs. 0 oz.	---	
	Circuit 2		36 lbs. 0 oz.	---	
	Circuit 3		31 lbs. 0 oz.	---	
	Circuit 4		31 lbs. 0 oz.	---	
Compressor Type (no.)			Scroll (4)	Scroll (4)	
Condenser Coils	Net face area - sq. ft. total		111.2	111.2	
	Tube diameter - in.		3/8	3/8	
	Number of rows		3	3	
	Fins per inch		20	20	
Condenser Fans	Motor horsepower		(6) 3/4	(6) 3/4	
	Motor rpm		1075	1075	
	Total Motor watts		4900	4900	
	Diameter - in.		(6) 24	(6) 24	
	No. of blades		4	4	
	Total Air volume - cfm		29,000	29,000	
Evaporator Coils	Net face area - sq. ft. total		37.4	37.4	
	Tube diameter - in.		3/8	3/8	
	No. of rows		4	4	
	Fins per inch		14	14	
	Drain connection - number and size		(1) 1 in. NPT coupling	(1) 1 in. NPT coupling	
	Expansion device type		Balanced Port Thermostatic Expansion Valve, removeable power head		
Indoor Blower and Drive Selection	Nominal motor output		5 to 30 hp available - See Blower Data Tables for selection		
	Motor - Drive kit		510 to 1340 rpm available - See Blower Drive Kit Tables for selection	510 to 1340 rpm available - See Blower Drive Kit Tables for selection	
	Blower wheel nominal dia. x width - in.		(2) 20 x 15	(2) 20 x 15	
Filters	Type of filter		Disposable, pleated MERV 4		
	No. and size - in.		(11) 25 x 16 x 2		
Electrical characteristics			208/230V, 460V or 575V - 60 hertz - 3 phase		

NOTE - Net capacity includes evaporator blower motor heat deduction. Gross capacity does not include evaporator blower motor heat deduction.

¹ Tested at conditions included in AHRI Standard 340/360; 95°F outdoor air temperature and 80°F db/67°F wb entering evaporator air; minimum external duct static pressure.

² Integrated Energy Efficiency Ratio tested according to AHRI Standard 340/360.

SPECIFICATIONS - 50 TON STANDARD EFFICIENCY

General Data		Nominal Tonnage	50 Ton	50 Ton	
		Model No.	600S4M	600S4V	
		Efficiency Type	Standard	Standard	
		Blower Type	MSAV® (Multi-Stage Air Volume)	Variable Air Volume (VAV)	
Cooling Performance	Gross Cooling Capacity - Btuh		598,000	598,000	
	¹ Net Cooling Capacity - Btuh		565,000	565,000	
	AHRI Rated Air Flow - cfm		16,000	16,000	
	Total Unit Power - kW		56.5	56.5	
	¹ EER (Btuh/Watt)		10.0	10.0	
	² IEER (Btuh/Watt)		13.5	13.2	
	Refrigerant Type		R-410A	R-410A	
	Refrigerant Charge Furnished	Circuit 1		31 lbs. 0 oz.	31 lbs. 0 oz.
		Circuit 2		31 lbs. 0 oz.	31 lbs. 0 oz.
		Circuit 3		31 lbs. 0 oz.	31 lbs. 0 oz.
Circuit 4			31 lbs. 0 oz.	31 lbs. 0 oz.	
Refrigerant Charge Furnished with Humiditrol® Dehumidification Option	Circuit 1		36 lbs. 0 oz.	---	
	Circuit 2		36 lbs. 0 oz.	---	
	Circuit 3		31 lbs. 0 oz.	---	
	Circuit 4		31 lbs. 0 oz.	---	
Compressor Type (no.)			Scroll (4)	Scroll (4)	
Condenser Coils	Net face area - sq. ft. total		111.2	111.2	
	Tube diameter - in.		3/8	3/8	
	Number of rows		3	3	
	Fins per inch		20	20	
Condenser Fans	Motor horsepower		(6) 1	(6) 1	
	Motor rpm		1140	1140	
	Total Motor watts		5000	5000	
	Diameter - in.		(6) 24	(6) 24	
	No. of blades		4	4	
	Total Air volume - cfm		35,000	35,000	
Evaporator Coils	Net face area - sq. ft. total		37.4	37.4	
	Tube diameter - in.		3/8	3/8	
	No. of rows		4	4	
	Fins per inch		14	14	
	Drain connection - number and size		(1) 1 in. NPT coupling	(1) 1 in. NPT coupling	
Expansion device type			Balanced Port Thermostatic Expansion Valve, removeable power head		
Indoor Blower and Drive Selection	Nominal motor output		5 to 30 hp available - See Blower Data Tables for selection		
	Motor - Drive kit		510 to 1340 rpm available - See Blower Drive Kit Tables for selection	510 to 1340 rpm available - See Blower Drive Kit Tables for selection	
	Blower wheel nominal dia. x width - in.		(2) 20 x 15	(2) 20 x 15	
Filters	Type of filter		Disposable, pleated MERV 4		
	No. and size - in.		(11) 25 x 16 x 2		
Electrical characteristics			208/230V, 460V or 575V - 60 hertz - 3 phase		

NOTE - Net capacity includes evaporator blower motor heat deduction. Gross capacity does not include evaporator blower motor heat deduction.

¹ Tested at conditions included in AHRI Standard 340/360; 95°F outdoor air temperature and 80°F db/67°F wb entering evaporator air; minimum external duct static pressure.

² Integrated Energy Efficiency Ratio tested according to AHRI Standard 340/360.

SPECIFICATIONS - GAS HEAT

Gas Heating Performance (2 Stage)		Heat Input Type	Standard 2 Stage	High 2 Stage
	Input - First Stage	Btuh (kW)	330,000 (96.6)	528,000 (154.6)
	Input - Second Stage	Btuh (kW)	500,000 (146.4)	800,000 (234.4)
	Output - First Stage	Btuh (kW)	---	---
	Output - Second Stage	Btuh (kW)	400,000 (117.1)	640,000 (187.4)
Gas Heating Performance (4 Stage)		Heat Input Type	Standard 4 Stage	High 4 Stage
	Input - First Stage	Btuh (kW)	165,000 (48.3)	264,000 (77.4)
	Input - Second Stage	Btuh (kW)	330,000 (96.7)	528,000 (154.7)
	Input - Third Stage	Btuh (kW)	415,000 (121.6)	664,000 (194.6)
	Input - Fourth Stage	Btuh (kW)	500,000 (146.5)	800,000 (234.4)
	Output - First Stage	Btuh (kW)	---	---
	Output - Second Stage	Btuh (kW)	---	---
	Output - Third Stage	Btuh (kW)	---	---
	Output - Fourth Stage	Btuh (kW)	400,000 (117.2)	640,000 (187.5)
Gas Heating Performance (Fully Modulating)		Heat Input Type	Standard Fully Modulating	High Fully Modulating
	Input - Minimum	Btuh (kW)	125,000 (36.6)	200,000 (58.6)
	Input - Full	Btuh (kW)	500,000 (146.5)	800,000 (234.4)
	Output - Minimum	Btuh (kW)	---	---
	Output - Full	Btuh (kW)	400,000 (117.2)	640,000 (187.5)
	Temperature Rise Range - °F		10 - 40	25 - 55
	Thermal Efficiency		80%	
	Gas Supply Connections		1-1/4 in. NPT	
Recommended Gas Supply Pressure	Natural		7 in. w.g. (1.5 kPa)	
	LPG/Propane		11 in. w.g. (2.7 kPa)	

HIGH ALTITUDE INFORMATION

Units are certified for operation from 0 to 2000 feet above sea level. If the unit is installed at altitudes above 2000 feet, the unit must be derated 4% for every 1000 feet above sea level. Thus, at an altitude of 4000 feet, the unit would require a 16% derate.

BLOWER DATA

BLOWER TABLE INCLUDES RESISTANCE FOR BASE UNIT ONLY WITH DRY INDOOR COIL AND AIR FILTERS IN PLACE

Add factory installed options air resistance, then determine from blower table blower motor output and drive kit required.

See page 19 for horizontal configured unit air resistance.

See page 20 for factory installed options air resistance data.

See page 21 for factory installed drive kit specifications.

TOTAL STATIC PRESSURE - 0.2 Thru 2.4 in. w.g. For 2.6 thru 4.6 in. w.g., see next page

Air Volume cfm	0.2		0.4		0.6		0.8		1.0		1.2		1.4		1.6		1.8		2.0		2.2		2.4	
	RPM	BHP	RPM	BHP	RPM	BHP	RPM	BHP	RPM	BHP	RPM	BHP	RPM	BHP	RPM	BHP	RPM	BHP	RPM	BHP	RPM	BHP	RPM	BHP
8000	---	---	---	---	562	0.90	593	1.76	625	2.59	658	3.37	692	4.11	728	4.81	765	5.48	802	6.14	838	6.80	873	7.46
8500	---	---	539	0.45	569	1.31	600	2.16	632	2.97	664	3.75	699	4.48	735	5.17	772	5.84	808	6.51	844	7.17	879	7.83
9000	---	---	547	0.87	576	1.73	607	2.57	639	3.38	672	4.14	706	4.87	743	5.56	779	6.23	815	6.90	851	7.56	885	8.22
9500	526	0.47	555	1.32	584	2.16	615	3.00	647	3.80	680	4.56	715	5.29	751	5.97	787	6.65	823	7.32	858	7.99	892	8.65
10,000	535	0.94	563	1.78	593	2.62	624	3.45	655	4.25	689	5.01	724	5.72	760	6.41	796	7.09	831	7.76	865	8.44	899	9.11
10,500	544	1.42	572	2.26	602	3.09	633	3.92	665	4.71	698	5.47	733	6.19	769	6.88	805	7.56	840	8.24	874	8.93	906	9.60
11,000	553	1.92	582	2.75	612	3.59	642	4.41	675	5.21	708	5.96	744	6.68	779	7.37	815	8.06	849	8.75	882	9.44	914	10.12
11,500	564	2.44	592	3.27	622	4.11	653	4.93	685	5.72	719	6.48	754	7.20	790	7.89	825	8.59	859	9.29	891	9.99	922	10.67
12,000	574	2.98	603	3.81	633	4.65	664	5.47	697	6.27	731	7.02	766	7.74	801	8.45	835	9.16	869	9.87	900	10.57	930	11.25
12,500	585	3.55	614	4.38	644	5.22	676	6.04	708	6.84	743	7.59	778	8.32	813	9.03	846	9.75	879	10.48	910	11.18	939	11.86
13,000	597	4.13	626	4.97	656	5.81	688	6.64	721	7.44	756	8.20	790	8.93	825	9.66	858	10.39	889	11.12	919	11.83	948	12.51
13,500	609	4.73	638	5.58	669	6.44	701	7.28	734	8.07	769	8.84	803	9.58	837	10.32	869	11.06	900	11.80	929	12.51	957	13.19
14,000	622	5.34	651	6.21	682	7.09	715	7.95	748	8.76	783	9.53	817	10.28	850	11.02	881	11.77	911	12.51	939	13.22	966	13.91
14,500	635	5.98	665	6.88	696	7.79	729	8.67	763	9.49	797	10.27	830	11.02	863	11.77	893	12.52	922	13.26	950	13.97	976	14.66
15,000	648	6.67	679	7.61	711	8.55	745	9.44	778	10.27	812	11.05	845	11.81	876	12.55	905	13.30	933	14.04	960	14.75	986	15.45
15,500	663	7.42	694	8.40	727	9.35	760	10.25	794	11.09	827	11.87	859	12.62	889	13.36	918	14.11	945	14.85	971	15.56	996	16.28
16,000	679	8.23	710	9.24	743	10.21	777	11.12	810	11.95	842	12.72	873	13.46	902	14.20	930	14.95	956	15.68	981	16.41	1006	17.15
16,500	695	9.11	727	10.14	760	11.11	793	12.01	826	12.83	857	13.60	887	14.33	915	15.06	942	15.81	967	16.56	992	17.30	1016	18.06
17,000	712	10.04	745	11.08	778	12.05	810	12.94	842	13.74	872	14.49	901	15.22	928	15.95	954	16.70	979	17.46	1003	18.23	1027	19.02
17,500	730	11.02	763	12.06	795	13.02	827	13.88	858	14.68	888	15.41	915	16.13	941	16.87	967	17.63	991	18.41	1015	19.21	1038	20.03
18,000	748	12.04	781	13.07	813	14.00	844	14.85	874	15.63	903	16.36	929	17.07	955	17.81	979	18.59	1003	19.41	1026	20.24	1049	21.10
18,500	767	13.10	799	14.10	831	15.02	861	15.85	890	16.61	917	17.33	943	18.05	968	18.81	992	19.62	1015	20.46	1038	21.34	1060	22.23
19,000	786	14.20	818	15.17	849	16.06	878	16.87	906	17.62	932	18.34	957	19.08	981	19.86	1005	20.70	1028	21.59	1050	22.50	1072	23.42
19,500	806	15.32	837	16.26	866	17.13	895	17.92	922	18.66	947	19.40	971	20.17	995	20.99	1018	21.86	1040	22.78	1063	23.72	1084	24.67
20,000	825	16.48	855	17.39	884	18.23	911	19.01	937	19.75	962	20.51	985	21.32	1008	22.17	1031	23.09	1053	24.04	1075	25.01	1097	25.98
20,500	845	17.67	874	18.55	902	19.37	928	20.13	953	20.89	976	21.68	1000	22.53	1022	23.43	1045	24.38	1067	25.37	1088	26.37	1110	27.35
21,000	864	18.89	892	19.74	919	20.53	944	21.30	968	22.09	991	22.92	1014	23.80	1036	24.75	1059	25.75	1080	26.77	1102	27.79	1123	28.78
21,500	883	20.13	910	20.95	936	21.73	960	22.52	984	23.34	1006	24.22	1029	25.15	1051	26.15	1073	27.19	1094	28.24	1116	29.27	1137	30.26
22,000	902	21.38	928	22.18	953	22.98	976	23.80	999	24.66	1021	25.59	1044	26.59	1066	27.64	1087	28.71	1109	29.77	1130	30.80	1151	31.79
22,500	921	22.65	945	23.46	969	24.28	992	25.14	1015	26.06	1037	27.05	1059	28.11	1081	29.20	1102	30.29	1123	31.36	1144	32.39	1165	33.37

NOTE - Minimum CFM requirements for units with electric heat:

LCH420 - 9800 cfm, LCH480 - 11,200 cfm, LCH540 - 12,600 cfm, LCH600 - 14,000 cfm.

BLOWER DATA

BLOWER TABLE INCLUDES RESISTANCE FOR BASE UNIT ONLY WITH DRY INDOOR COIL AND AIR FILTERS IN PLACE

Add factory installed options air resistance, then determine from blower table blower motor output and drive kit required.

See page 19 for horizontal configured unit air resistance.

See page 20 for factory installed options air resistance data.

See page 21 for factory installed drive kit specifications.

TOTAL STATIC PRESSURE - 2.6 Thru 4.6 in. w.g. For .2 thru 2.4 in. w.g., see previous page

Air Volume cfm	2.6		2.8		3.0		3.2		3.4		3.6		3.8		4.0		4.2		4.4		4.6	
	RPM	BHP	RPM	BHP	RPM	BHP	RPM	BHP	RPM	BHP	RPM	BHP	RPM	BHP	RPM	BHP	RPM	BHP	RPM	BHP	RPM	BHP
8000	908	8.1	940	8.72	970	9.33	1000	9.95	1029	10.59	1057	11.25	1084	11.91	1110	12.60	1136	13.31	1161	14.01	1188	14.71
8500	913	8.47	944	9.10	975	9.73	1004	10.36	1032	11.00	1059	11.66	1086	12.35	1113	13.06	1139	13.79	1165	14.54	1191	15.30
9000	918	8.87	949	9.51	979	10.15	1007	10.78	1035	11.43	1062	12.10	1089	12.81	1115	13.54	1141	14.28	1168	15.04	1194	15.83
9500	924	9.30	954	9.95	983	10.59	1011	11.24	1038	11.89	1065	12.58	1092	13.30	1118	14.03	1144	14.79	1170	15.56	1197	16.36
10,000	930	9.76	960	10.42	988	11.07	1015	11.72	1042	12.39	1068	13.08	1095	13.81	1121	14.55	1147	15.31	1173	16.09	1199	16.90
10,500	937	10.26	966	10.91	994	11.57	1020	12.24	1046	12.92	1072	13.62	1098	14.35	1124	15.10	1150	15.86	1176	16.65	1202	17.45
11,000	944	10.78	972	11.44	999	12.11	1025	12.79	1051	13.48	1076	14.19	1102	14.93	1128	15.68	1153	16.44	1178	17.22	1204	18.02
11,500	951	11.33	979	12.00	1005	12.68	1031	13.37	1056	14.08	1081	14.80	1106	15.54	1131	16.29	1156	17.05	1181	17.82	1207	18.61
12,000	959	11.92	986	12.6	1012	13.29	1037	13.99	1062	14.71	1086	15.44	1111	16.18	1135	16.93	1160	17.69	1185	18.46	1210	19.25
12,500	967	12.54	993	13.23	1018	13.93	1043	14.65	1068	15.38	1092	16.12	1116	16.87	1140	17.62	1164	18.37	1189	19.14	1214	19.92
13,000	975	13.19	1001	13.89	1026	14.61	1050	15.34	1074	16.09	1098	16.84	1121	17.59	1145	18.34	1169	19.09	1193	19.85	1218	20.64
13,500	983	13.88	1008	14.59	1033	15.33	1057	16.08	1081	16.84	1104	17.60	1127	18.36	1151	19.11	1174	19.85	1198	20.61	1223	21.40
14,000	992	14.61	1017	15.33	1041	16.09	1064	16.86	1088	17.63	1111	18.40	1134	19.16	1157	19.91	1180	20.66	1204	21.42	1229	22.21
14,500	1001	15.37	1025	16.12	1049	16.89	1072	17.68	1095	18.47	1118	19.24	1141	20.00	1163	20.75	1187	21.50	1210	22.26	1235	23.05
15,000	1010	16.18	1034	16.94	1057	17.73	1080	18.54	1103	19.34	1125	20.12	1148	20.88	1170	21.63	1193	22.38	1217	23.14	1242	23.94
15,500	1020	17.03	1043	17.81	1066	18.62	1089	19.44	1111	20.25	1133	21.04	1156	21.80	1178	22.55	1201	23.29	1224	24.06	1249	24.88
16,000	1029	17.92	1052	18.73	1075	19.56	1097	20.39	1120	21.20	1142	21.99	1164	22.75	1186	23.50	1209	24.25	1232	25.03	1258	25.86
16,500	1039	18.86	1062	19.69	1084	20.54	1107	21.37	1128	22.19	1150	22.98	1172	23.74	1194	24.49	1217	25.25	1241	26.05	1266	26.89
17,000	1050	19.85	1072	20.70	1094	21.56	1116	22.40	1138	23.22	1159	24.01	1181	24.77	1203	25.53	1226	26.30	1250	27.11	1275	27.97
17,500	1060	20.89	1082	21.76	1104	22.62	1126	23.47	1147	24.29	1169	25.07	1190	25.84	1213	26.61	1236	27.40	1260	28.22	1285	29.10
18,000	1071	21.99	1093	22.87	1115	23.74	1136	24.58	1157	25.40	1179	26.19	1200	26.96	1223	27.74	1246	28.54	1270	29.38	1296	30.27
18,500	1082	23.14	1104	24.03	1125	24.90	1147	25.75	1168	26.56	1189	27.35	1211	28.13	1233	28.92	1256	29.73	1281	30.58	1306	31.48
19,000	1094	24.34	1115	25.25	1136	26.12	1158	26.96	1179	27.78	1200	28.57	1222	29.35	1244	30.14	1267	30.96	1292	31.81	1317	32.71
19,500	1106	25.61	1127	26.52	1148	27.39	1169	28.23	1190	29.04	1211	29.83	1233	30.61	1255	31.40	1279	32.21	1303	33.06	1329	33.95
20,000	1118	26.93	1139	27.84	1160	28.71	1181	29.55	1202	30.35	1223	31.13	1245	31.91	1267	32.69	1290	33.50	1315	34.34	---	---
20,500	1131	28.30	1152	29.21	1172	30.08	1193	30.90	1214	31.70	1235	32.47	1257	33.23	1279	34.01	---	---	---	---	---	---
21,000	1144	29.73	1165	30.63	1185	31.48	1206	32.30	1226	33.08	1247	33.84	---	---	---	---	---	---	---	---	---	---
21,500	1157	31.20	1178	32.09	1198	32.93	1218	33.73	1239	34.49	---	---	---	---	---	---	---	---	---	---	---	---
22,000	1171	32.72	1191	33.59	1211	34.41	---	---	---	---	---	---	---	---	---	---	---	---	---	---	---	---
22,500	1185	34.28	---	---	---	---	---	---	---	---	---	---	---	---	---	---	---	---	---	---	---	---

NOTE - Minimum CFM requirements for units with electric heat:

LCH420 - 9800 cfm, LCH480 - 11,200 cfm, LCH540 - 12,600 cfm, LCH600 - 14,000 cfm.

BLOWER DATA

POWER EXHAUST BLOWERS

¹ 50% HIGH STATIC OPERATION, NO ERW

Air Volume cfm	Return Duct Negative Static Pressure - Inches Water Gauge (Pa)																					
	0		0.1		0.2		0.3		0.4		0.5		0.6		0.7		0.8		0.9		1.0	
	RPM	BHP	RPM	BHP	RPM	BHP	RPM	BHP	RPM	BHP	RPM	BHP	RPM	BHP	RPM	BHP	RPM	BHP	RPM	BHP	RPM	BHP
4000	410	0.75	465	1.00	520	1.25	575	1.50	630	1.80	685	2.15	740	2.50	795	2.85	845	3.25	900	3.70	955	4.15
4500	460	1.10	510	1.35	560	1.60	610	1.90	655	2.20	705	2.55	755	2.90	805	3.30	850	3.70	900	4.15	945	4.55
5000	510	1.50	555	1.75	600	2.05	645	2.40	690	2.70	735	3.10	775	3.40	820	3.85	865	4.25	910	4.70	950	5.15
5500	560	2.00	600	2.25	645	2.60	685	2.95	725	3.30	765	3.70	805	4.05	845	4.50	885	4.90	925	5.35	965	5.85
6000	610	2.55	650	2.90	685	3.25	725	3.60	760	3.95	800	4.40	835	4.80	870	5.20	910	5.65	945	6.10	980	6.55
6500	665	3.30	700	3.65	730	3.95	765	4.35	800	4.75	835	5.20	870	5.60	905	6.10	935	6.50	970	7.00	1005	7.50
7000	715	4.10	745	4.45	780	4.90	810	5.25	840	5.65	875	6.15	905	6.55	940	7.05	970	7.50	1000	8.00	1030	8.50
7500	765	5.05	795	5.45	825	5.85	855	6.30	885	6.75	915	7.20	945	7.65	975	8.15	---	---	---	---	---	---
8000	815	6.10	845	6.55	870	6.95	900	7.45	930	7.95	955	8.35	---	---	---	---	---	---	---	---	---	---
8500	865	7.30	895	7.80	920	8.25	---	---	---	---	---	---	---	---	---	---	---	---	---	---	---	---

POWER EXHAUST BLOWERS

¹ 100% HIGH STATIC OPERATION, NO ERW

Air Volume cfm	Return Duct Negative Static Pressure - Inches Water Gauge (Pa)																					
	0		0.1		0.2		0.3		0.4		0.5		0.6		0.7		0.8		0.9		1.0	
	RPM	BHP	RPM	BHP	RPM	BHP	RPM	BHP	RPM	BHP	RPM	BHP	RPM	BHP	RPM	BHP	RPM	BHP	RPM	BHP	RPM	BHP
8000	410	1.45	450	1.70	495	2.05	535	2.35	580	2.70	625	3.10	665	3.50	710	3.95	750	4.40	790	4.85	835	5.35
8500	435	1.70	475	2.00	515	2.35	555	2.70	595	3.05	635	3.45	675	3.85	715	4.30	755	4.75	795	5.25	835	5.75
9000	460	2.05	495	2.35	535	2.70	575	3.05	610	3.40	650	3.85	690	4.30	725	4.70	765	5.20	800	5.65	840	6.20
9500	485	2.40	520	2.70	555	3.05	595	3.45	630	3.85	665	4.25	700	4.70	740	5.20	775	5.65	810	6.15	845	6.65
10,000	510	2.80	545	3.15	580	3.50	615	3.90	650	4.35	680	4.70	715	5.15	750	5.65	785	6.15	820	6.65	855	7.20
10,500	535	3.20	570	3.60	600	3.95	635	4.40	665	4.80	700	5.25	730	5.70	765	6.20	795	6.65	830	7.20	860	7.70
11,000	560	3.70	590	4.05	625	4.50	655	4.90	685	5.35	720	5.85	750	6.30	780	6.75	810	7.25	840	7.75	875	8.40
11,500	585	4.20	615	4.60	645	5.05	675	5.45	705	5.90	735	6.40	765	6.90	795	7.40	825	7.90	855	8.45	885	9.00
12,000	610	4.80	640	5.20	670	5.70	700	6.15	725	6.55	755	7.05	785	7.60	815	8.10	840	8.60	870	9.15	900	9.75
12,500	635	5.40	665	5.90	690	6.30	720	6.80	750	7.30	775	7.75	805	8.30	830	8.80	860	9.40	885	9.90	915	10.55
13,000	660	6.10	690	6.60	715	7.00	740	7.45	770	8.05	795	8.50	820	9.00	850	9.65	875	10.15	900	10.70	930	11.35
13,500	690	6.90	715	7.35	740	7.80	765	8.30	790	8.80	815	9.30	840	9.85	865	10.40	895	11.05	920	11.65	945	12.20
14,000	715	7.65	740	8.15	765	8.65	785	9.10	810	9.60	835	10.15	860	10.70	885	11.30	910	11.90	935	12.50	960	13.10
14,500	740	8.50	765	9.05	785	9.45	810	10.00	835	10.60	860	11.20	880	11.65	905	12.25	930	12.90	955	13.55	975	14.05
15,000	765	9.40	785	9.85	810	10.45	835	11.05	855	11.50	880	12.15	905	12.75	925	13.30	950	13.95	970	14.50	995	15.20
15,500	790	10.35	810	10.85	835	11.45	855	11.95	880	12.60	900	13.15	925	13.80	945	14.35	970	15.05	990	15.65	1015	16.35
16,000	815	11.40	835	11.90	860	12.55	880	13.10	900	13.65	925	14.35	945	14.90	965	15.50	990	16.20	1010	16.85	---	---
16,500	840	12.50	860	13.05	885	13.70	905	14.30	925	14.85	945	15.45	965	16.05	990	16.80	---	---	---	---	---	---
17,000	865	13.65	885	14.20	905	14.80	925	15.40	950	16.15	970	16.80	---	---	---	---	---	---	---	---	---	---
17,500	890	14.85	910	15.50	930	16.10	950	16.75	---	---	---	---	---	---	---	---	---	---	---	---	---	---
18,000	915	16.15	935	16.80	---	---	---	---	---	---	---	---	---	---	---	---	---	---	---	---	---	---

NOTE - See page 21 for factory installed drive kit specifications.

¹ Size power exhaust blowers in economizer mode to minimize building static pressure during free^o cooling.

BLOWER DATA

POWER EXHAUST BLOWERS

¹ 50% HIGH STATIC OPERATION WITH ERW (BY-PASS DAMPERS CLOSED)

Air Volume cfm	Return Duct Negative Static Pressure - Inches Water Gauge (Pa)																					
	0		0.1		0.2		0.3		0.4		0.5		0.6		0.7		0.8		0.9		1.0	
	RPM	BHP	RPM	BHP	RPM	BHP	RPM	BHP	RPM	BHP	RPM	BHP	RPM	BHP	RPM	BHP	RPM	BHP	RPM	BHP	RPM	BHP
2500	390	0.35	460	0.50	530	0.70	600	0.90	670	1.15	735	1.40	805	1.70	870	2.00	935	2.35	1005	2.75	1070	3.10
3000	465	0.60	525	0.75	585	1.00	645	1.20	700	1.45	760	1.75	815	2.05	870	2.35	930	2.70	985	3.05	1040	3.45
3500	545	0.95	595	1.15	645	1.35	695	1.60	745	1.90	795	2.20	845	2.50	895	2.85	945	3.20	990	3.55	1040	3.95
4000	620	1.35	665	1.60	710	1.90	755	2.15	800	2.45	840	2.75	885	3.10	930	3.45	975	3.80	1015	4.15	1060	4.60
4500	700	1.95	740	2.25	780	2.55	820	2.85	855	3.10	895	3.45	935	3.80	975	4.20	1015	4.60	1050	4.95	---	---
5000	775	2.70	815	3.00	850	3.30	885	3.65	920	4.00	955	4.35	990	4.70	1025	5.10	1060	5.50	---	---	---	---
5500	855	3.60	885	3.90	920	4.25	950	4.60	985	5.00	1015	5.35	1050	5.75	---	---	---	---	---	---	---	---
6000	935	4.70	965	5.05	990	5.35	1020	5.75	1050	6.15	---	---	---	---	---	---	---	---	---	---	---	---

POWER EXHAUST BLOWERS

¹ 100% HIGH STATIC OPERATION WITH ERW (BY-PASS DAMPERS CLOSED)

Air Volume cfm	Return Duct Negative Static Pressure - Inches Water Gauge (Pa)																					
	0		0.1		0.2		0.3		0.4		0.5		0.6		0.7		0.8		0.9		1.0	
	RPM	BHP	RPM	BHP	RPM	BHP	RPM	BHP	RPM	BHP	RPM	BHP	RPM	BHP	RPM	BHP	RPM	BHP	RPM	BHP	RPM	BHP
5000	445	0.85	505	1.15	565	1.45	625	1.85	680	2.20	740	2.65	800	3.15	855	3.60	910	4.15	970	4.75	1025	5.30
5500	490	1.15	545	1.45	600	1.80	650	2.15	705	2.55	760	3.05	810	3.50	865	4.00	915	4.55	970	5.15	1020	5.70
6000	535	1.45	585	1.80	635	2.15	685	2.60	735	3.00	780	3.45	830	3.95	880	4.50	925	5.00	975	5.60	1020	6.15
6500	580	1.85	625	2.20	670	2.60	715	3.00	760	3.45	805	3.95	850	4.45	895	4.95	940	5.50	985	6.10	1030	6.75
7000	625	2.35	665	2.70	710	3.15	750	3.55	795	4.05	835	4.50	880	5.05	920	5.60	960	6.15	1005	6.80	1045	7.40
7500	670	2.90	710	3.30	750	3.75	790	4.20	825	4.65	865	5.15	905	5.70	945	6.25	985	6.85	1025	7.50	1060	8.05
8000	715	3.50	750	3.90	790	4.40	825	4.85	860	5.35	900	5.90	935	6.45	975	7.05	1010	7.65	1045	8.25	---	---
8500	760	4.20	795	4.65	830	5.15	865	5.65	900	6.20	935	6.75	970	7.30	1000	7.85	1035	8.45	1070	9.10	---	---
9000	800	4.90	835	5.45	870	5.95	900	6.45	935	7.05	970	7.65	1000	8.20	1035	8.85	1065	9.40	---	---	---	---
9500	845	5.80	880	6.35	910	6.85	940	7.40	975	8.05	1005	8.60	1035	9.20	1065	9.80	---	---	---	---	---	---
10,000	890	6.75	920	7.30	950	7.85	980	8.45	1010	9.05	1040	9.65	1070	10.30	---	---	---	---	---	---	---	---
10,500	935	7.85	965	8.45	995	9.05	1020	9.60	1050	10.25	---	---	---	---	---	---	---	---	---	---	---	---
11,000	980	9.00	1010	9.65	1035	10.25	1060	10.80	---	---	---	---	---	---	---	---	---	---	---	---	---	---
11,500	1025	10.30	1050	10.90	---	---	---	---	---	---	---	---	---	---	---	---	---	---	---	---	---	---
12,000	1070	11.75	---	---	---	---	---	---	---	---	---	---	---	---	---	---	---	---	---	---	---	---

NOTE - See page 21 for factory installed drive kit specifications.

¹ Size power exhaust blowers with ERW in economizer mode to minimize building static pressure during free² cooling.

BLOWER DATA

POWER EXHAUST BLOWERS

¹ 50% HIGH STATIC OPERATION WITH ERW IN ECONOMIZER MODE (BY-PASS DAMPERS OPEN)

Air Volume cfm	Return Duct Negative Static Pressure - Inches Water Gauge (Pa)																					
	0		0.1		0.2		0.3		0.4		0.5		0.6		0.7		0.8		0.9		1.0	
	RPM	BHP	RPM	BHP	RPM	BHP	RPM	BHP	RPM	BHP	RPM	BHP	RPM	BHP	RPM	BHP	RPM	BHP	RPM	BHP	RPM	BHP
3500	380	0.55	435	0.70	495	0.90	555	1.10	615	1.35	675	1.60	730	1.85	790	2.15	845	2.45	900	2.80	960	3.15
4000	430	0.80	485	1.00	535	1.20	585	1.40	640	1.65	690	1.95	740	2.20	790	2.50	845	2.85	895	3.20	945	3.55
4500	485	1.10	530	1.30	575	1.55	625	1.80	670	2.05	715	2.35	760	2.65	805	2.95	855	3.30	900	3.65	945	4.00
5000	540	1.55	580	1.75	620	2.00	665	2.30	705	2.55	745	2.85	790	3.20	830	3.50	870	3.85	910	4.15	950	4.55
5500	590	2.05	630	2.30	670	2.60	705	2.85	745	3.15	780	3.45	820	3.80	855	4.10	895	4.50	930	4.80	970	5.25
6000	645	2.65	680	2.90	715	3.20	750	3.50	785	3.85	820	4.15	855	4.50	890	4.85	925	5.25	960	5.65	995	6.05
6500	700	3.35	730	3.65	765	4.00	795	4.30	830	4.65	860	5.00	890	5.30	925	5.70	955	6.10	990	6.50	1020	6.90
7000	755	4.20	785	4.55	815	4.90	845	5.20	875	5.60	905	5.95	935	6.35	960	6.65	990	7.05	1020	7.45	1050	7.90
7500	805	5.15	835	5.50	865	5.90	890	6.20	920	6.60	945	6.95	975	7.40	1000	7.75	1030	8.20	1060	8.65	---	---
8000	860	6.25	885	6.60	915	7.05	940	7.40	965	7.80	990	8.15	1020	8.65	1045	9.05	1070	9.45	---	---	---	---
8500	915	7.55	940	7.90	965	8.35	990	8.75	1015	9.15	1040	9.60	1060	9.95	---	---	---	---	---	---	---	---

POWER EXHAUST BLOWERS

¹ 100% HIGH STATIC OPERATION WITH ERW IN ECONOMIZER MODE (BY-PASS DAMPERS OPEN)

Air Volume cfm	Return Duct Negative Static Pressure - Inches Water Gauge (Pa)																					
	0		0.1		0.2		0.3		0.4		0.5		0.6		0.7		0.8		0.9		1.0	
	RPM	BHP	RPM	BHP	RPM	BHP	RPM	BHP	RPM	BHP	RPM	BHP	RPM	BHP	RPM	BHP	RPM	BHP	RPM	BHP	RPM	BHP
7000	415	1.15	470	1.50	520	1.80	570	2.10	620	2.50	675	2.90	725	3.35	775	3.80	825	4.30	875	4.80	925	5.35
7500	445	1.45	495	1.75	540	2.05	590	2.45	640	2.85	685	3.25	735	3.70	780	4.15	825	4.65	875	5.20	920	5.70
8000	475	1.75	520	2.05	565	2.40	610	2.80	655	3.20	700	3.65	745	4.10	790	4.55	835	5.10	880	5.60	920	6.10
8500	505	2.10	545	2.40	590	2.80	635	3.25	675	3.60	715	4.05	760	4.55	800	5.00	845	5.55	885	6.05	925	6.60
9000	535	2.50	575	2.85	615	3.25	655	3.65	695	4.10	735	4.55	775	5.00	815	5.50	855	6.05	895	6.60	935	7.15
9500	565	2.95	600	3.30	640	3.70	680	4.15	715	4.55	755	5.05	790	5.50	830	6.05	870	6.60	905	7.15	945	7.75
10,000	595	3.45	630	3.80	665	4.20	700	4.65	740	5.15	775	5.65	810	6.10	845	6.65	880	7.15	920	7.80	955	8.35
10,500	625	4.00	660	4.40	690	4.80	725	5.25	760	5.75	795	6.25	830	6.75	865	7.30	900	7.90	935	8.50	965	9.00
11,000	655	4.60	685	4.95	720	5.45	750	5.90	785	6.40	820	6.95	850	7.45	885	8.05	915	8.55	950	9.20	980	9.75
11,500	680	5.15	715	5.65	745	6.10	775	6.60	810	7.15	840	7.65	870	8.20	905	8.80	935	9.40	965	9.95	995	10.55
12,000	710	5.85	740	6.35	775	6.90	805	7.40	835	7.95	865	8.50	895	9.05	925	9.65	955	10.25	985	10.85	1015	11.50
12,500	740	6.65	770	7.15	800	7.70	830	8.25	860	8.80	885	9.30	915	9.90	945	10.50	975	11.15	1005	11.80	1030	12.35
13,000	770	7.50	800	8.05	825	8.50	855	9.10	885	9.70	910	10.20	940	10.85	965	11.40	995	12.10	1020	12.65	1050	13.40
13,500	800	8.40	830	9.00	855	9.50	880	10.00	910	10.65	935	11.20	965	11.90	990	12.50	1015	13.10	1045	13.85	---	---
14,000	830	9.35	855	9.90	885	10.55	910	11.10	935	11.70	960	12.30	985	12.90	1010	13.50	1040	14.25	1065	14.90	---	---
14,500	860	10.40	885	11.00	910	11.55	935	12.15	960	12.75	985	13.40	1010	14.05	1035	14.70	1060	15.40	---	---	---	---
15,000	890	11.55	915	12.15	940	12.75	965	13.40	985	13.95	1010	14.60	1035	15.30	1060	16.00	---	---	---	---	---	---
15,500	920	12.75	945	13.40	965	13.90	990	14.60	1015	15.30	1035	15.85	1060	16.60	---	---	---	---	---	---	---	---
16,000	950	14.00	970	14.55	995	15.25	1020	16.00	1040	16.60	1065	17.35	---	---	---	---	---	---	---	---	---	---
16,500	980	15.35	1000	15.95	1025	16.70	1045	17.30	1065	17.95	---	---	---	---	---	---	---	---	---	---	---	---
17,000	1010	16.80	1030	17.45	1050	18.10	---	---	---	---	---	---	---	---	---	---	---	---	---	---	---	---

NOTE - See page 21 for factory installed drive kit specifications.

¹ Size power exhaust blowers with ERW in economizer mode to minimize building static pressure during free² cooling.

BLOWER DATA

POWER EXHAUST BLOWERS

STANDARD STATIC (1 TWO BLOWER OPERATION)

Return Duct Negative Static Pressure Inches Water Gauge	Air Volume cfm	Return Duct Negative Static Pressure Inches Water Gauge	Air Volume cfm
0	12,100	0.50	5700
0.05	11,600	0.55	5000
0.10	11,150	0.60	4300
0.15	10,600	0.65	3800
0.20	10,100	0.70	3400
0.25	9500	0.75	3000
0.30	8900	0.80	2500
0.35	8200	0.85	2300
0.40	7400	0.90	2000
0.45	6500		

¹ For one blower operation, use half of the air volume value.

OUTDOOR AIR PERCENTAGE VS. FRESH AIR DAMPER ANGLE - Less ERW

Fresh Air Damper Opening Angle	Percentage of Outdoor Air Available at Various Return Duct Static Pressures - in. w.g.			
	0.2	0.4	0.6	0.8
10°	5%	11%	16%	21%
20°	19%	25%	30%	36%
30°	34%	39%	44%	50%
40°	48%	53%	59%	64%
50°	62%	68%	73%	79%
60°	77%	82%	87%	93%
70°	91%	96%	100%	100%
80°	100%	100%	100%	100%

NOTE - Outdoor air percentage will vary when a variable frequency drive (VFD) drive is used on the supply air blower.

OUTDOOR AIR PERCENTAGE VS. FRESH AIR DAMPER ANGLE - With ERW

1 ERW Static Pressure in. w.g.	Percentage of Outdoor Air Available at Various Return Duct Static Pressures																		
	0 Return Duct Static						0.2 Return Duct Static						0.4 Return Duct Static						
	1.2	1.0	0.8	0.6	0.4	0.2	1.2	1.0	0.8	0.6	0.4	0.2	1.2	1.0	0.8	0.6	0.4	0.2	
Fresh Air Damper Opening Angle	10°	---	---	---	---	---	---	---	---	---	---	---	---	---	---	---	---	---	
	20°	9%	4%	---	---	---	---	14%	9%	4%	---	---	---	19%	14%	9%	4%	---	---
	30°	23%	18%	13%	8%	2%	---	28%	23%	18%	13%	8%	2%	34%	28%	23%	18%	13%	8%
	40°	38%	32%	27%	22%	17%	11%	43%	38%	32%	27%	22%	17%	48%	43%	38%	32%	27%	22%
	50°	52%	46%	41%	36%	31%	25%	57%	52%	46%	41%	36%	31%	62%	57%	52%	46%	41%	36%
	60°	66%	61%	55%	50%	45%	39%	71%	66%	61%	55%	50%	45%	77%	71%	66%	61%	55%	50%
	70°	81%	75%	70%	64%	59%	54%	86%	81%	75%	70%	64%	59%	91%	86%	81%	75%	70%	64%
	80°	95%	89%	84%	78%	73%	68%	100%	95%	89%	84%	78%	73%	100%	100%	95%	89%	84%	78%
1 ERW Static Pressure in. w.g.	Percentage of Outdoor Air Available at Various Return Duct Static Pressures																		
	0.6 Return Duct Static						0.8 Return Duct Static												
	1.2	1.0	0.8	0.6	0.4	0.2	1.2	1.0	0.8	0.6	0.4	0.2							
Fresh Air Damper Opening Angle	10°	---	---	---	---	---	---	---	---	---	---	---	---	---	---	---	---	---	---
	20°	25%	19%	14%	9%	4%	---	30%	25%	19%	14%	9%	4%	---	---	---	---	---	---
	30°	39%	34%	28%	23%	18%	13%	44%	39%	34%	28%	23%	18%	---	---	---	---	---	---
	40°	54%	48%	43%	38%	32%	27%	59%	54%	48%	43%	38%	32%	---	---	---	---	---	---
	50°	68%	62%	57%	52%	46%	41%	73%	68%	62%	57%	52%	46%	---	---	---	---	---	---
	60°	84%	77%	71%	66%	61%	55%	87%	84%	77%	71%	66%	61%	---	---	---	---	---	---
	70°	97%	91%	86%	81%	75%	70%	100%	97%	91%	86%	81%	75%	---	---	---	---	---	---
	80°	100%	100%	100%	95%	89%	84%	100%	100%	100%	100%	100%	95%	89%	84%	78%	73%	68%	63%

NOTE - Outdoor air percentage will vary when a variable frequency drive (VFD) drive is used on the supply air blower.

¹ See page 22 for Energy Recovery Wheel Specifications.

BLOWER DATA**AIR RESISTANCE****HORIZONTAL AIRFLOW APPLICATIONS**

Air Volume	Standard Static Power Exhaust Fans or No Power Exhaust Fans	50% High Static Power Exhaust Blowers	100% High Static Power Exhaust Blowers
cfm	in. w.g.	in. w.g.	in. w.g.
10,000	.20	.23	.25
10,500	.20	.25	.30
11,000	.20	.25	.30
11,500	.20	.30	.40
12,000	.20	.33	.45
12,500	.20	.35	.50
13,000	.20	.38	.55
13,500	.25	.43	.60
14,000	.25	.45	.65
14,500	.25	.48	.70
15,000	.30	.55	.80
15,500	.30	.58	.85
16,000	.30	.63	.95
16,500	.30	.63	.95
17,000	.30	.68	1.05
17,500	.30	.70	1.10
18,000	.30	.75	1.20
18,500	.30	.78	1.25
19,000	.30	.83	1.35
19,500	.30	.83	1.40
20,000	.30	.90	1.50
20,500	.35	.94	1.60
21,000	.35	.98	1.70
21,500	.35	1.02	1.80
22,000	.35	1.04	1.90
22,500	.35	1.10	2.00

BLOWER DATA

FACTORY INSTALLED OPTIONS ACCESSORY AIR RESISTANCE

ECONOMIZER RETURN AIR DAMPER WITH ERW

Outdoor Air Volume With ERW cfm	Return Duct Negative Static Pressure 0 in. w.g.				
	0.2	0.4	0.6	0.8	1.0
3250	0.32	0.12	---	---	---
3500	0.36	0.16	---	---	---
3750	0.40	0.20	---	---	---
4000	0.44	0.24	0.04	---	---
4250	0.48	0.28	0.08	---	---
4500	0.52	0.32	0.12	---	---
4750	0.57	0.37	0.17	---	---
5000	0.60	0.40	0.20	---	---
5250	0.65	0.45	0.25	0.05	---
5500	0.68	0.48	0.28	0.08	---
5750	0.73	0.53	0.33	0.13	---
6000	0.76	0.56	0.36	0.16	---
6250	0.81	0.61	0.41	0.21	0.01
6500	0.84	0.64	0.44	0.24	0.04
6750	0.89	0.69	0.49	0.29	0.09
7000	0.93	0.73	0.53	0.33	0.13
7250	0.97	0.77	0.57	0.37	0.17
7500	1.01	0.81	0.61	0.41	0.21
7750	1.05	0.85	0.65	0.45	0.25
8000	1.09	0.89	0.69	0.49	0.29
8250	1.13	0.93	0.73	0.53	0.33
8500	1.17	0.97	0.77	0.57	0.37
8750	1.21	1.01	0.81	0.61	0.41
9000	1.25	1.05	0.85	0.65	0.45

FACTORY INSTALLED OPTIONS ACCESSORY AIR RESISTANCE

Air Volume cfm	Wet Indoor Coil	Humiditrol® Condenser Reheat Coil	Electric Heat	Economizer	Filters			
					MERV 8		MERV 13	
					2 inch	4 inch	2 inch	4 inch
in. w.g.	in. w.g.	in. w.g.	in. w.g.	in. w.g.	in. w.g.	in. w.g.	in. w.g.	
8000	0.16	---	0.07	---	0.03	0.05	0.11	0.06
9000	0.21	---	0.07	---	0.03	0.05	0.13	0.07
10,000	0.25	---	0.07	0.02	0.04	0.06	0.14	0.08
11,000	0.29	---	0.07	0.08	0.04	0.06	0.16	0.08
12,000	0.32	---	0.07	0.12	0.05	0.07	0.17	0.09
13,000	0.37	---	0.07	0.17	0.05	0.07	0.18	0.10
14,000	0.42	0.01	0.07	0.19	0.05	0.08	0.20	0.11
15,000	0.46	0.01	0.08	0.22	0.06	0.09	0.21	0.11
16,000	0.51	0.02	0.09	0.23	0.06	0.09	0.23	0.12
17,000	0.56	0.04	0.10	0.25	0.06	0.10	0.24	0.13
18,000	0.60	0.06	0.13	0.26	0.07	0.10	0.26	0.14
19,000	0.68	0.09	0.14	0.26	0.07	0.11	0.27	0.14
20,000	0.70	0.11	0.18	0.26	0.07	0.11	0.28	0.15
21,000	0.78	0.15	0.20	0.26	0.08	0.12	0.30	0.16
22,000	0.82	0.19	0.21	0.26	0.08	0.12	0.31	0.17

BLOWER DRIVE KITS

DRIVE KIT SPECIFICATIONS

Nominal hp	Maximum hp	Drive Kit Number	RPM Range (Adjustable Pulley)
5	5.75	1	510 - 640
		2	630 - 760
7.5	8.63	3	635 - 770
		4	750 - 905
10	11.5	5	670 - 825
		4	750 - 905
		6	880 - 1050
15	17.25	7	745 - 900
		8	875 - 1045
		9	965 - 1190
20	23	10	825 - 1020
		11	1010 - 1240
25	28.75	12	930 - 1085
		13	1075 - 1285
30	34.5	13	1075 - 1285
		14	1150 - 1340

NOTE - Using total air volume and system static pressure requirements determine from blower performance tables rpm and motor output required. Maximum usable output of motors furnished are shown. In Canada, nominal motor hp is also maximum usable motor hp. If motors of comparable output are used, be sure to keep within the service factor limitations outlined on the motor nameplate.

For Variable Frequency Drive applications, nominal motor output is also maximum usable motor output.

HIGH STATIC POWER EXHAUST BLOWERS - DRIVE KIT SPECIFICATIONS

Nominal hp per blower	¹ Maximum hp per blower	RPM Range ³ Adjustable	Drive Kit Number		
			50% Applications Rear Position	² 100% Applications Order One Each:	
				Front Position	Rear Position
3	3.45	735-920	6(A)-B35	6(B)-B36	6(A)-B35
		690-845	5(A)-B35	5(B)-B36	5(A)-B35
5	5.75	795-975	3(A)-B35	3(B)-B36	3(A)-B35
		735-920	4(A)-B35	4(B)-B36	4(A)-B35
7.5	8.63	850-1065	1(A)-B35	1(B)-B36	1(A)-B35
		820-980	2(A)-B35	2(B)-B36	2(A)-B35

¹ In VFD applications, nominal motor output is also maximum usable motor output.

² Two drive kits are required for the same rpm, one for the front blower position and one for the rear blower position because of different belt length requirements.

³ Adjustable motor pulleys are factory set for maximum RPM in VFD applications.

ENERGY RECOVERY WHEEL SPECIFICATIONS

¹ Enthalpy Wheel AHRI Rating Data	Nominal Airflow		6600 cfm		
	EATR - Exhaust Air Transfer Ratio	at minus 1 in. w. c.	4.6%		
		at 0 in. w.c.	1.9%		
		at 1 in. w.c.	0.9%		
	OACF Outdoor Air Correction Factor	at minus 1 in. w. c.	0.99%		
		at 0 in. w.c.	1.05%		
at 1 in. w.c.		1.08%			
¹ Thermal Ratings at 0.95 in. w.c. Pressure Differential			Sensible	Latent	Total
	Total Effectiveness	100% Airflow Heating	68	60	65
		75% Airflow Heating	73	67	71
		100% Airflow Cooling	68	60	63
		75% Airflow Cooling	73	67	70
	Net Effectiveness	100% Airflow Heating	68	60	65
100% Airflow Cooling		68	60	63	
Dimensions		diameter x width - in. (mm)			
		63 x 3 (1600 x 76)			

¹ Rated in accordance with AHRI Standard 1060-2001. For further information, please reference AHRI 1060-2005 Standard For Rating Air-to-Air Heat Exchangers For Energy Recovery Ventilation Equipment.

EFFECTIVENESS

Air Flow cfm	Static Pressure in. w.c.	Effectiveness (%)			
		Sensible	Latent	Total	
				Cooling	Heating
3250	0.45	79.7	75.1	76.9	78.0
3500	0.48	78.8	73.9	75.9	77.0
3750	0.52	77.9	72.8	74.9	76.1
4000	0.55	77.0	71.7	73.8	54.1
4250	0.59	76.1	70.6	72.8	74.1
4500	0.62	75.3	69.4	71.8	73.2
4750	0.66	74.4	68.3	70.7	72.2
5000	0.69	73.5	67.2	69.7	71.2
5250	0.73	72.6	66.1	68.7	70.3
5500	0.76	71.8	64.9	67.7	69.3
5750	0.80	70.9	63.8	66.6	68.3
6000	0.83	70.0	62.7	65.6	67.4
6250	0.87	69.1	61.6	64.6	66.4
6500	0.90	68.2	60.4	63.5	65.4
6750	0.94	67.4	59.3	62.5	64.5
7000	0.97	66.5	58.2	61.5	63.5
7250	1.01	65.6	57.1	60.4	62.5
7500	1.04	64.7	55.9	59.4	61.6
7750	1.08	63.8	54.8	58.4	60.6
8000	1.11	62.9	53.6	57.3	59.6
8250	1.15	62.0	52.5	56.3	58.7
8500	1.18	61.1	51.4	55.2	57.7
8750	1.22	60.3	50.2	54.2	56.7
9000	1.25	59.4	49.1	53.1	55.7

ELECTRICAL DATA

35 TON STANDARD EFFICIENCY (R-410A)			LCH420S4						
¹ Voltage - 60hz			208/230V - 3 Ph						
Compressor 1	Rated Load Amps		29.5						
	Locked Rotor Amps		195						
Compressor 2	Rated Load Amps		29.5						
	Locked Rotor Amps		195						
Compressor 3	Rated Load Amps		29.5						
	Locked Rotor Amps		195						
Compressor 4	Rated Load Amps		29.5						
	Locked Rotor Amps		195						
Outdoor Fan	Full Load Amps		3.7						
Motors (6)	(total)		(22.2)						
Service Outlet 115V GFI (amps)			15						
Indoor Blower Motor	Horsepower		5	7.5	10	15	20	25	30
	Full Load Amps		16.7	24.2	30.8	46.2	59.4	74.8	78
² Maximum Overcurrent Protection	Unit Only		175	200	200	225	250	⁴ 300	⁴ 300
	Power Exhaust	50% Standard Static (1) 1 hp motor	200	200	200	250	250	⁴ 300	⁴ 300
		100% Standard Static (2) 1 hp motor	200	200	200	250	250	⁴ 300	⁴ 300
		50% High Static (1) 3 hp motor	200	200	200	250	250	⁴ 300	⁴ 300
		100% High Static (2) 3 hp motor	200	200	225	250	250	⁴ 300	⁴ 300
		50% High Static (1) 5 hp motor	200	200	225	250	250	⁴ 300	⁴ 300
		100% High Static (2) 5 hp motor	225	225	225	250	⁴ 300	⁴ 300	⁴ 350
		50% High Static (1) 7.5 hp motor	200	225	225	250	⁴ 300	⁴ 300	⁴ 300
		100% High Static (2) 7.5 hp motor	225	250	250	250	⁴ 300	⁴ 350	⁴ 350
³ Minimum Circuit Ampacity	Unit Only		167	175	181	201	217	236	240
	Power Exhaust	50% Standard Static (1) 1 hp motor	172	179	186	206	222	241	245
		100% Standard Static (2) 1 hp motor	177	184	191	210	227	246	250
		50% High Static (1) 3 hp motor	178	185	192	211	228	247	251
		100% High Static (2) 3 hp motor	188	196	203	222	238	258	262
		50% High Static (1) 5 hp motor	184	191	198	217	234	253	257
		100% High Static (2) 5 hp motor	200	208	215	234	251	270	274
		50% High Static (1) 7.5 hp motor	191	199	205	221	234	249	253
		100% High Static (2) 7.5 hp motor	215	223	230	249	266	285	289

NOTE - All units have a minimum Short Circuit Current Rating (SCCR) of 5000 amps.

¹ Extremes of operating range are plus and minus 10% of line voltage.

² HACR type breaker or fuse.

³ Refer to National or Canadian Electrical Code manual to determine wire, fuse and disconnect size requirements.

⁴ Factory installed circuit breaker not available.

ELECTRICAL DATA

35 TON STANDARD EFFICIENCY (R-410A)			LCH420S4						
¹ Voltage - 60hz			460V - 3 Ph						
Compressor 1	Rated Load Amps		14.8						
	Locked Rotor Amps		95						
Compressor 2	Rated Load Amps		14.8						
	Locked Rotor Amps		95						
Compressor 3	Rated Load Amps		14.8						
	Locked Rotor Amps		95						
Compressor 4	Rated Load Amps		14.8						
	Locked Rotor Amps		95						
Outdoor Fan Motors (6)	Full Load Amps (total)		1.9 (11.4)						
Service Outlet 115V GFI (amps)			15						
Indoor Blower Motor	Horsepower		5	7.5	10	15	20	25	30
	Full Load Amps		7.6	11	14	21	27	34	35
² Maximum Overcurrent Protection	Unit Only		90	100	100	110	125	125	150
	Power Exhaust	50% Standard Static (1) 1 hp motor	100	100	100	110	125	150	150
		100% Standard Static (2) 1 hp motor	100	100	100	110	125	150	150
		50% High Static (1) 3 hp motor	100	100	100	110	125	150	150
		100% High Static (2) 3 hp motor	100	100	100	110	125	150	150
		50% High Static (1) 5 hp motor	100	100	110	125	125	150	150
		100% High Static (2) 5 hp motor	110	110	110	125	125	150	150
		50% High Static (1) 7.5 hp motor	100	110	110	125	125	150	150
		100% High Static (2) 7.5 hp motor	125	125	125	125	150	150	150
³ Minimum Circuit Ampacity	Unit Only		84	87	90	99	106	115	116
	Power Exhaust	50% Standard Static (1) 1 hp motor	86	89	92	101	108	117	118
		100% Standard Static (2) 1 hp motor	88	92	95	103	111	120	121
		50% High Static (1) 3 hp motor	88	92	95	103	111	120	121
		100% High Static (2) 3 hp motor	93	97	100	108	116	124	126
		50% High Static (1) 5 hp motor	91	95	98	106	114	122	124
		100% High Static (2) 5 hp motor	99	102	105	114	121	130	131
		50% High Static (1) 7.5 hp motor	95	98	101	110	117	126	127
		100% High Static (2) 7.5 hp motor	106	109	112	121	128	137	138

NOTE - All units have a minimum Short Circuit Current Rating (SCCR) of 5000 amps.

¹ Extremes of operating range are plus and minus 10% of line voltage.

² HACR type breaker or fuse.

³ Refer to National or Canadian Electrical Code manual to determine wire, fuse and disconnect size requirements.

ELECTRICAL DATA

35 TON STANDARD EFFICIENCY (R-410A)			LCH420S4						
¹ Voltage - 60hz			575V - 3 Ph						
Compressor 1	Rated Load Amps		12.2						
	Locked Rotor Amps		80						
Compressor 2	Rated Load Amps		12.2						
	Locked Rotor Amps		80						
Compressor 3	Rated Load Amps		12.2						
	Locked Rotor Amps		80						
Compressor 4	Rated Load Amps		12.2						
	Locked Rotor Amps		80						
Outdoor Fan Motors (6)	Full Load Amps (total)		1.6 (9.6)						
Service Outlet 115V GFI (amps)			20						
Indoor Blower Motor	Horsepower		5	7.5	10	15	20	25	30
	Full Load Amps		6.1	9	11	17	22	27	32
² Maximum Overcurrent Protection	Unit Only		80	80	80	90	100	110	125
	Power Exhaust	50% Standard Static (1) 1 hp motor	80	80	80	90	110	110	125
		100% Standard Static (2) 1 hp motor	80	80	80	100	110	110	125
		50% High Static (1) 3 hp motor	80	80	80	100	110	110	125
		100% High Static (2) 3 hp motor	80	90	90	100	110	125	125
		50% High Static (1) 5 hp motor	80	80	90	100	110	125	125
		100% High Static (2) 5 hp motor	90	90	90	100	110	125	125
		50% High Static (1) 7.5 hp motor	80	90	90	100	110	125	125
		100% High Static (2) 7.5 hp motor	90	100	100	110	125	125	125
³ Minimum Circuit Ampacity	Unit Only		69	72	74	81	87	94	100
	Power Exhaust	50% Standard Static (1) 1 hp motor	71	74	76	83	89	96	102
		100% Standard Static (2) 1 hp motor	73	76	78	85	91	98	104
		50% High Static (1) 3 hp motor	73	76	78	85	91	98	104
		100% High Static (2) 3 hp motor	77	80	82	89	95	101	108
		50% High Static (1) 5 hp motor	75	78	80	87	93	100	106
		100% High Static (2) 5 hp motor	81	84	86	93	100	106	112
		50% High Static (1) 7.5 hp motor	78	81	83	90	96	103	109
		100% High Static (2) 7.5 hp motor	87	90	92	99	105	112	118

NOTE - All units have a minimum Short Circuit Current Rating (SCCR) of 5000 amps.

¹ Extremes of operating range are plus and minus 10% of line voltage.

² HACR type breaker or fuse.

³ Refer to National or Canadian Electrical Code manual to determine wire, fuse and disconnect size requirements.

ELECTRICAL DATA

35 TON HIGH EFFICIENCY (R-410A)			LCH420H4						
¹ Voltage - 60hz			208/230V - 3 Ph						
Compressor 1	Rated Load Amps		29.5						
	Locked Rotor Amps		195						
Compressor 2	Rated Load Amps		29.5						
	Locked Rotor Amps		195						
Compressor 3	Rated Load Amps		29.5						
	Locked Rotor Amps		195						
Compressor 4	Rated Load Amps		29.5						
	Locked Rotor Amps		195						
Outdoor Fan	Full Load Amps		4.8						
Motors (6)	(total)		(28.8)						
Service Outlet 115V GFI (amps)			15						
Indoor Blower Motor	Horsepower		5	7.5	10	15	20	25	30
	Full Load Amps		16.7	24.2	30.8	46.2	59.4	74.8	78
² Maximum Overcurrent Protection	Unit Only		200	200	200	250	250	⁴ 300	⁴ 300
	Power Exhaust	50% Standard Static (1) 1 hp motor	200	200	200	250	250	⁴ 300	⁴ 300
		100% Standard Static (2) 1 hp motor	200	200	225	250	250	⁴ 300	⁴ 300
		50% High Static (1) 3 hp motor	200	200	225	250	250	⁴ 300	⁴ 300
		100% High Static (2) 3 hp motor	200	225	225	250	⁴ 300	⁴ 300	⁴ 300
		50% High Static (1) 5 hp motor	200	225	225	250	250	⁴ 300	⁴ 300
		100% High Static (2) 5 hp motor	225	225	250	250	⁴ 300	⁴ 350	⁴ 350
		50% High Static (1) 7.5 hp motor	225	225	225	250	⁴ 300	⁴ 300	⁴ 300
		100% High Static (2) 7.5 hp motor	250	250	250	⁴ 300	⁴ 300	⁴ 350	⁴ 350
³ Minimum Circuit Ampacity	Unit Only		174	181	188	207	224	243	247
	Power Exhaust	50% Standard Static (1) 1 hp motor	178	186	193	212	229	248	252
		100% Standard Static (2) 1 hp motor	183	191	198	217	233	253	257
		50% High Static (1) 3 hp motor	184	192	199	218	234	254	258
		100% High Static (2) 3 hp motor	195	202	209	229	245	264	268
		50% High Static (1) 5 hp motor	190	198	205	224	241	260	264
		100% High Static (2) 5 hp motor	207	215	221	241	257	276	280
		50% High Static (1) 7.5 hp motor	198	205	212	227	241	256	259
		100% High Static (2) 7.5 hp motor	222	230	236	256	272	291	295

NOTE - All units have a minimum Short Circuit Current Rating (SCCR) of 5000 amps.

¹ Extremes of operating range are plus and minus 10% of line voltage.

² HACR type breaker or fuse.

³ Refer to National or Canadian Electrical Code manual to determine wire, fuse and disconnect size requirements.

⁴ Factory installed circuit breaker not available.

ELECTRICAL DATA

35 TON HIGH EFFICIENCY (R-410A)			LCH420H4						
¹ Voltage - 60hz			460V - 3 Ph						
Compressor 1	Rated Load Amps		14.8						
	Locked Rotor Amps		95						
Compressor 2	Rated Load Amps		14.8						
	Locked Rotor Amps		95						
Compressor 3	Rated Load Amps		14.8						
	Locked Rotor Amps		95						
Compressor 4	Rated Load Amps		14.8						
	Locked Rotor Amps		95						
Outdoor Fan Motors (6)	Full Load Amps		2.4						
	(total)		(14.4)						
Service Outlet 115V GFI (amps)			15						
Indoor Blower Motor	Horsepower		5	7.5	10	15	20	25	30
	Full Load Amps		7.6	11	14	21	27	34	35
² Maximum Overcurrent Protection	Unit Only		100	100	100	110	125	150	150
	Power Exhaust	50% Standard Static (1) 1 hp motor	100	100	100	110	125	150	150
		100% Standard Static (2) 1 hp motor	100	100	110	125	125	150	150
		50% High Static (1) 3 hp motor	100	100	110	125	125	150	150
		100% High Static (2) 3 hp motor	100	100	110	125	125	150	150
		50% High Static (1) 5 hp motor	100	110	110	125	125	150	150
		100% High Static (2) 5 hp motor	110	110	110	125	150	150	175
		50% High Static (1) 7.5 hp motor	110	110	110	125	125	150	175
		100% High Static (2) 7.5 hp motor	125	150	150	125	150	150	175
³ Minimum Circuit Ampacity	Unit Only		87	90	93	102	109	118	125
	Power Exhaust	50% Standard Static (1) 1 hp motor	89	92	95	104	111	120	128
		100% Standard Static (2) 1 hp motor	91	95	98	106	114	123	130
		50% High Static (1) 3 hp motor	91	95	98	106	114	123	130
		100% High Static (2) 3 hp motor	96	100	103	111	119	127	135
		50% High Static (1) 5 hp motor	94	98	101	109	117	125	133
		100% High Static (2) 5 hp motor	102	105	108	117	124	133	140
		50% High Static (1) 7.5 hp motor	98	101	104	113	120	129	136
		100% High Static (2) 7.5 hp motor	109	112	115	124	131	140	147

NOTE - All units have a minimum Short Circuit Current Rating (SCCR) of 5000 amps.

¹ Extremes of operating range are plus and minus 10% of line voltage.

² HACR type breaker or fuse.

³ Refer to National or Canadian Electrical Code manual to determine wire, fuse and disconnect size requirements.

ELECTRICAL DATA

35 TON HIGH EFFICIENCY (R-410A)		LCH420H4							
¹ Voltage - 60hz		575V - 3 Ph							
Compressor 1	Rated Load Amps	12.2							
	Locked Rotor Amps	80							
Compressor 2	Rated Load Amps	12.2							
	Locked Rotor Amps	80							
Compressor 3	Rated Load Amps	12.2							
	Locked Rotor Amps	80							
Compressor 4	Rated Load Amps	12.2							
	Locked Rotor Amps	80							
Outdoor Fan Motors (6)	Full Load Amps	2							
	(total)	(12)							
Service Outlet 115V GFI (amps)		20							
Indoor Blower Motor	Horsepower	5	7.5	10	15	20	25	30	
	Full Load Amps	6.1	9	11	17	22	27	32	
² Maximum Overcurrent Protection	Unit Only		80	80	80	100	110	110	125
	Power Exhaust	50% Standard Static (1) 1 hp motor	80	80	90	100	110	110	125
		100% Standard Static (2) 1 hp motor	80	90	90	100	110	125	125
		50% High Static (1) 3 hp motor	80	90	90	100	110	125	125
		100% High Static (2) 3 hp motor	90	90	90	100	110	125	125
		50% High Static (1) 5 hp motor	80	90	90	100	110	125	125
		100% High Static (2) 5 hp motor	90	90	100	110	110	125	125
		50% High Static (1) 7.5 hp motor	90	90	90	100	110	125	125
		100% High Static (2) 7.5 hp motor	100	100	100	110	125	125	150
³ Minimum Circuit Ampacity	Unit Only		71	74	76	84	90	96	102
	Power Exhaust	50% Standard Static (1) 1 hp motor	73	76	78	86	92	98	104
		100% Standard Static (2) 1 hp motor	75	78	80	88	94	100	106
		50% High Static (1) 3 hp motor	75	78	80	87	94	100	106
		100% High Static (2) 3 hp motor	79	82	84	91	98	104	110
		50% High Static (1) 5 hp motor	78	80	82	90	96	102	108
		100% High Static (2) 5 hp motor	84	87	89	96	102	108	114
		50% High Static (1) 7.5 hp motor	80	83	85	93	99	105	111
		100% High Static (2) 7.5 hp motor	89	92	94	102	108	114	120

NOTE - All units have a minimum Short Circuit Current Rating (SCCR) of 5000 amps.

¹ Extremes of operating range are plus and minus 10% of line voltage.

² HACR type breaker or fuse.

³ Refer to National or Canadian Electrical Code manual to determine wire, fuse and disconnect size requirements.

ELECTRICAL DATA

40 TON STANDARD EFFICIENCY (R-410A)			LCH480S4						
¹ Voltage - 60hz			208/230V - 3 Ph						
Compressor 1	Rated Load Amps		30.1						
	Locked Rotor Amps		225						
Compressor 2	Rated Load Amps		30.1						
	Locked Rotor Amps		225						
Compressor 3	Rated Load Amps		30.1						
	Locked Rotor Amps		225						
Compressor 4	Rated Load Amps		30.1						
	Locked Rotor Amps		225						
Outdoor Fan Motors (6)	Full Load Amps		3.7						
	(total)		(22.2)						
Service Outlet 115V GFI (amps)			15						
Indoor Blower Motor	Horsepower		5	7.5	10	15	20	25	30
	Full Load Amps		16.7	24.2	30.8	46.2	59.4	74.8	78
² Maximum Overcurrent Protection	Unit Only		175	200	200	225	250	⁴ 300	⁴ 300
	Power Exhaust	50% Standard Static (1) 1 hp motor	200	200	200	250	250	⁴ 300	⁴ 300
		100% Standard Static (2) 1 hp motor	200	200	200	250	250	⁴ 300	⁴ 300
		50% High Static (1) 3 hp motor	200	200	225	250	250	⁴ 300	⁴ 300
		100% High Static (2) 3 hp motor	200	225	225	250	⁴ 300	⁴ 300	⁴ 300
		50% High Static (1) 5 hp motor	200	200	225	250	250	⁴ 300	⁴ 300
		100% High Static (2) 5 hp motor	225	225	225	250	⁴ 300	⁴ 300	⁴ 350
		50% High Static (1) 7.5 hp motor	200	225	225	250	⁴ 300	⁴ 300	⁴ 300
		100% High Static (2) 7.5 hp motor	225	250	250	250	⁴ 300	⁴ 350	⁴ 350
³ Minimum Circuit Ampacity	Unit Only		170	178	184	204	220	239	243
	Power Exhaust	50% Standard Static (1) 1 hp motor	175	182	189	208	225	244	248
		100% Standard Static (2) 1 hp motor	180	187	194	213	230	249	253
		50% High Static (1) 3 hp motor	181	188	195	214	231	250	254
		100% High Static (2) 3 hp motor	191	199	205	225	241	260	264
		50% High Static (1) 5 hp motor	187	194	201	220	237	256	260
		100% High Static (2) 5 hp motor	203	211	218	237	253	273	277
		50% High Static (1) 7.5 hp motor	194	202	208	224	237	252	256
		100% High Static (2) 7.5 hp motor	218	226	233	252	268	288	292

NOTE - All units have a minimum Short Circuit Current Rating (SCCR) of 5000 amps.

¹ Extremes of operating range are plus and minus 10% of line voltage.

² HACR type breaker or fuse.

³ Refer to National or Canadian Electrical Code manual to determine wire, fuse and disconnect size requirements.

⁴ Factory installed circuit breaker not available.

ELECTRICAL DATA

40 TON STANDARD EFFICIENCY (R-410A)			LCH480S4						
¹ Voltage - 60hz			460V - 3 Ph						
Compressor 1	Rated Load Amps		16.7						
	Locked Rotor Amps		114						
Compressor 2	Rated Load Amps		16.7						
	Locked Rotor Amps		114						
Compressor 3	Rated Load Amps		16.7						
	Locked Rotor Amps		114						
Compressor 4	Rated Load Amps		16.7						
	Locked Rotor Amps		114						
Outdoor Fan Motors (6)	Full Load Amps		1.9						
	(total)		(11.4)						
Service Outlet 115V GFI (amps)			15						
Indoor Blower Motor	Horsepower		5	7.5	10	15	20	25	30
	Full Load Amps		7.6	11	14	21	27	34	35
² Maximum Overcurrent Protection	Unit Only		100	110	110	125	125	150	150
	Power Exhaust	50% Standard Static (1) 1 hp motor	110	110	110	125	125	150	150
		100% Standard Static (2) 1 hp motor	110	110	110	125	125	150	150
		50% High Static (1) 3 hp motor	110	110	110	125	125	150	150
		100% High Static (2) 3 hp motor	110	110	110	125	125	150	150
		50% High Static (1) 5 hp motor	110	110	110	125	125	150	150
		100% High Static (2) 5 hp motor	110	125	125	125	150	150	150
		50% High Static (1) 7.5 hp motor	110	110	125	125	150	150	150
		100% High Static (2) 7.5 hp motor	125	150	150	150	150	175	175
³ Minimum Circuit Ampacity	Unit Only		92	95	98	106	114	122	124
	Power Exhaust	50% Standard Static (1) 1 hp motor	94	97	100	109	116	125	126
		100% Standard Static (2) 1 hp motor	96	100	103	111	118	127	128
		50% High Static (1) 3 hp motor	96	100	103	111	118	127	128
		100% High Static (2) 3 hp motor	101	105	108	116	123	132	133
		50% High Static (1) 5 hp motor	99	103	106	114	121	130	131
		100% High Static (2) 5 hp motor	107	110	113	121	129	138	139
		50% High Static (1) 7.5 hp motor	103	106	109	117	125	133	135
		100% High Static (2) 7.5 hp motor	114	117	120	128	136	144	146

NOTE - All units have a minimum Short Circuit Current Rating (SCCR) of 5000 amps.

¹ Extremes of operating range are plus and minus 10% of line voltage.

² HACR type breaker or fuse.

³ Refer to National or Canadian Electrical Code manual to determine wire, fuse and disconnect size requirements.

ELECTRICAL DATA

40 TON STANDARD EFFICIENCY (R-410A)			LCH480S4						
¹ Voltage - 60hz			575V - 3 Ph						
Compressor 1	Rated Load Amps		12.2						
	Locked Rotor Amps		80						
Compressor 2	Rated Load Amps		12.2						
	Locked Rotor Amps		80						
Compressor 3	Rated Load Amps		12.2						
	Locked Rotor Amps		80						
Compressor 4	Rated Load Amps		12.2						
	Locked Rotor Amps		80						
Outdoor Fan Motors (6)	Full Load Amps		1.6						
	(total)		(9.6)						
Service Outlet 115V GFI (amps)			20						
Indoor Blower Motor	Horsepower		5	7.5	10	15	20	25	30
	Full Load Amps		6.1	9	11	17	22	27	32
² Maximum Overcurrent Protection	Unit Only		80	80	80	90	100	110	125
	Power Exhaust	50% Standard Static (1) 1 hp motor	80	80	80	90	110	110	125
		100% Standard Static (2) 1 hp motor	80	80	80	100	110	110	125
		50% High Static (1) 3 hp motor	80	80	80	100	110	110	125
		100% High Static (2) 3 hp motor	80	90	90	100	110	125	125
		50% High Static (1) 5 hp motor	80	80	90	100	110	125	125
		100% High Static (2) 5 hp motor	90	90	90	100	110	125	125
		50% High Static (1) 7.5 hp motor	80	90	90	100	110	125	125
		100% High Static (2) 7.5 hp motor	90	100	100	110	125	125	125
	³ Minimum Circuit Ampacity	Unit Only		69	72	74	81	87	94
Power Exhaust		50% Standard Static (1) 1 hp motor	71	74	76	83	89	96	102
		100% Standard Static (2) 1 hp motor	73	76	78	85	91	98	104
		50% High Static (1) 3 hp motor	73	76	78	85	91	98	104
		100% High Static (2) 3 hp motor	77	80	82	89	95	101	108
		50% High Static (1) 5 hp motor	75	78	80	87	93	100	106
		100% High Static (2) 5 hp motor	81	84	86	93	100	106	112
		50% High Static (1) 7.5 hp motor	78	81	83	90	96	103	109
		100% High Static (2) 7.5 hp motor	87	90	92	99	105	112	118

NOTE - All units have a minimum Short Circuit Current Rating (SCCR) of 5000 amps.

¹ Extremes of operating range are plus and minus 10% of line voltage.

² HACR type breaker or fuse.

³ Refer to National or Canadian Electrical Code manual to determine wire, fuse and disconnect size requirements.

ELECTRICAL DATA

40 TON HIGH EFFICIENCY (R-410A)			LCH480H4						
¹ Voltage - 60hz			208/230V - 3 Ph						
Compressor 1	Rated Load Amps		30.1						
	Locked Rotor Amps		225						
Compressor 2	Rated Load Amps		30.1						
	Locked Rotor Amps		225						
Compressor 3	Rated Load Amps		30.1						
	Locked Rotor Amps		225						
Compressor 4	Rated Load Amps		30.1						
	Locked Rotor Amps		225						
Outdoor Fan Motors (6)	Full Load Amps		4.8						
	(total)		(28.8)						
Service Outlet 115V GFI (amps)			15						
Indoor Blower Motor	Horsepower		5	7.5	10	15	20	25	30
	Full Load Amps		16.7	24.2	30.8	46.2	59.4	74.8	78
² Maximum Overcurrent Protection	Unit Only		200	200	200	250	250	⁴ 300	⁴ 300
	Power Exhaust	50% Standard Static (1) 1 hp motor	200	200	225	250	250	⁴ 300	⁴ 300
		100% Standard Static (2) 1 hp motor	200	200	225	250	250	⁴ 300	⁴ 300
		50% High Static (1) 3 hp motor	200	200	225	250	250	⁴ 300	⁴ 300
		100% High Static (2) 3 hp motor	225	225	225	250	⁴ 300	⁴ 300	⁴ 300
		50% High Static (1) 5 hp motor	200	225	225	250	⁴ 300	⁴ 300	⁴ 300
		100% High Static (2) 5 hp motor	225	225	250	250	⁴ 300	⁴ 350	⁴ 350
		50% High Static (1) 7.5 hp motor	225	225	225	250	⁴ 300	⁴ 300	⁴ 350
		100% High Static (2) 7.5 hp motor	250	250	250	⁴ 300	⁴ 300	⁴ 350	⁴ 350
³ Minimum Circuit Ampacity	Unit Only		177	184	191	210	227	246	250
	Power Exhaust	50% Standard Static (1) 1 hp motor	181	189	196	215	231	251	255
		100% Standard Static (2) 1 hp motor	186	194	200	220	236	255	259
		50% High Static (1) 3 hp motor	187	195	201	221	237	256	260
		100% High Static (2) 3 hp motor	198	205	212	231	248	267	271
		50% High Static (1) 5 hp motor	193	201	208	227	243	263	267
		100% High Static (2) 5 hp motor	210	218	224	244	260	279	283
		50% High Static (1) 7.5 hp motor	201	208	215	230	244	259	262
		100% High Static (2) 7.5 hp motor	225	233	239	259	275	294	298

NOTE - All units have a minimum Short Circuit Current Rating (SCCR) of 5000 amps.

¹ Extremes of operating range are plus and minus 10% of line voltage.

² HACR type breaker or fuse.

³ Refer to National or Canadian Electrical Code manual to determine wire, fuse and disconnect size requirements.

⁴ Factory installed circuit breaker not available.

ELECTRICAL DATA

40 TON HIGH EFFICIENCY (R-410A)			LCH480H4						
¹ Voltage - 60hz			460V - 3 Ph						
Compressor 1	Rated Load Amps		16.7						
	Locked Rotor Amps		114						
Compressor 2	Rated Load Amps		16.7						
	Locked Rotor Amps		114						
Compressor 3	Rated Load Amps		16.7						
	Locked Rotor Amps		114						
Compressor 4	Rated Load Amps		16.7						
	Locked Rotor Amps		114						
Outdoor Fan Motors (6)	Full Load Amps (total)		2.4 (14.4)						
Service Outlet 115V GFI (amps)			15						
Indoor Blower Motor	Horsepower		5	7.5	10	15	20	25	30
	Full Load Amps		7.6	11	14	21	27	34	35
² Maximum Overcurrent Protection	Unit Only		110	110	110	125	125	150	150
	Power Exhaust	50% Standard Static (1) 1 hp motor	110	110	110	125	125	150	150
		100% Standard Static (2) 1 hp motor	110	110	110	125	125	150	150
		50% High Static (1) 3 hp motor	110	110	110	125	125	150	150
		100% High Static (2) 3 hp motor	110	110	125	125	150	150	150
		50% High Static (1) 5 hp motor	110	110	110	125	150	150	150
		100% High Static (2) 5 hp motor	125	125	125	125	150	150	175
		50% High Static (1) 7.5 hp motor	110	125	125	125	150	150	150
		100% High Static (2) 7.5 hp motor	125	125	125	150	150	175	175
³ Minimum Circuit Ampacity	Unit Only		95	98	101	109	117	125	127
	Power Exhaust	50% Standard Static (1) 1 hp motor	97	100	103	112	119	128	129
		100% Standard Static (2) 1 hp motor	99	103	106	114	121	130	131
		50% High Static (1) 3 hp motor	99	103	106	114	121	130	131
		100% High Static (2) 3 hp motor	104	108	111	119	126	135	136
		50% High Static (1) 5 hp motor	102	106	109	117	124	133	134
		100% High Static (2) 5 hp motor	110	113	116	124	132	141	142
		50% High Static (1) 7.5 hp motor	106	109	112	120	128	136	138
		100% High Static (2) 7.5 hp motor	117	120	123	131	139	147	149

NOTE - All units have a minimum Short Circuit Current Rating (SCCR) of 5000 amps.

¹ Extremes of operating range are plus and minus 10% of line voltage.

² HACR type breaker or fuse.

³ Refer to National or Canadian Electrical Code manual to determine wire, fuse and disconnect size requirements.

ELECTRICAL DATA

40 TON HIGH EFFICIENCY (R-410A)

LCH480H4

¹ Voltage - 60hz

575V - 3 Ph

Compressor 1	Rated Load Amps	12.2
	Locked Rotor Amps	80
Compressor 2	Rated Load Amps	12.2
	Locked Rotor Amps	80
Compressor 3	Rated Load Amps	12.2
	Locked Rotor Amps	80
Compressor 4	Rated Load Amps	12.2
	Locked Rotor Amps	80
Outdoor Fan Motors (6)	Full Load Amps	2
	(total)	(12)

Service Outlet 115V GFI (amps)	20
--------------------------------	----

Indoor Blower Motor	Horsepower	5	7.5	10	15	20	25	30
	Full Load Amps	6.1	9	11	17	22	27	32

² Maximum Overcurrent Protection	Unit Only		80	80	80	100	110	110	125
	Power Exhaust	50% Standard Static (1) 1 hp motor	80	80	90	100	110	110	125
		100% Standard Static (2) 1 hp motor	80	90	90	100	110	125	125
		50% High Static (1) 3 hp motor	80	90	90	100	110	125	125
		100% High Static (2) 3 hp motor	90	90	90	100	110	125	125
		50% High Static (1) 5 hp motor	80	90	90	100	110	125	125
		100% High Static (2) 5 hp motor	90	90	100	110	110	125	125
		50% High Static (1) 7.5 hp motor	90	90	90	100	110	125	125
		100% High Static (2) 7.5 hp motor	100	100	100	110	125	125	150

³ Minimum Circuit Ampacity	Unit Only		71	74	76	84	90	96	102
	Power Exhaust	50% Standard Static (1) 1 hp motor	73	76	78	86	92	98	104
		100% Standard Static (2) 1 hp motor	75	78	80	88	94	100	106
		50% High Static (1) 3 hp motor	75	78	80	87	94	100	106
		100% High Static (2) 3 hp motor	79	82	84	91	98	104	110
		50% High Static (1) 5 hp motor	78	80	82	90	96	102	108
		100% High Static (2) 5 hp motor	84	87	89	96	102	108	114
		50% High Static (1) 7.5 hp motor	80	83	85	93	99	105	111
		100% High Static (2) 7.5 hp motor	89	92	94	102	108	114	120

NOTE - All units have a minimum Short Circuit Current Rating (SCCR) of 5000 amps.

¹ Extremes of operating range are plus and minus 10% of line voltage.

² HACR type breaker or fuse.

³ Refer to National or Canadian Electrical Code manual to determine wire, fuse and disconnect size requirements.

ELECTRICAL DATA

45 TON STANDARD EFFICIENCY (R-410A)			LCH540S4						
¹ Voltage - 60hz			208/230V - 3 Ph						
Compressor 1	Rated Load Amps		33.3						
	Locked Rotor Amps		239						
Compressor 2	Rated Load Amps		33.3						
	Locked Rotor Amps		239						
Compressor 3	Rated Load Amps		33.3						
	Locked Rotor Amps		239						
Compressor 4	Rated Load Amps		33.3						
	Locked Rotor Amps		239						
Outdoor Fan Motors (6)	Full Load Amps (total)		3.7 (22.2)						
Service Outlet 115V GFI (amps)			15						
Indoor Blower Motor	Horsepower		5	7.5	10	15	20	25	30
	Full Load Amps		16.7	24.2	30.8	46.2	59.4	74.8	78
² Maximum Overcurrent Protection	Unit Only		200	200	225	250	250	⁴ 300	⁴ 300
	Power Exhaust	50% Standard Static (1) 1 hp motor	200	225	225	250	250	⁴ 300	⁴ 300
		100% Standard Static (2) 1 hp motor	225	225	225	250	⁴ 300	⁴ 300	⁴ 300
		50% High Static (1) 3 hp motor	225	225	225	250	⁴ 300	⁴ 300	⁴ 300
		100% High Static (2) 3 hp motor	225	225	250	250	⁴ 300	⁴ 300	⁴ 350
		50% High Static (1) 5 hp motor	225	225	225	250	⁴ 300	⁴ 300	⁴ 350
		100% High Static (2) 5 hp motor	225	250	250	⁴ 300	⁴ 300	⁴ 350	⁴ 350
		50% High Static (1) 7.5 hp motor	225	225	250	250	⁴ 300	⁴ 350	⁴ 350
		100% High Static (2) 7.5 hp motor	250	250	250	⁴ 300	⁴ 300	⁴ 350	⁴ 350
³ Minimum Circuit Ampacity	Unit Only		184	191	198	216	233	252	256
	Power Exhaust	50% Standard Static (1) 1 hp motor	188	196	203	221	238	257	261
		100% Standard Static (2) 1 hp motor	193	201	207	226	242	262	266
		50% High Static (1) 3 hp motor	194	202	208	227	243	263	267
		100% High Static (2) 3 hp motor	205	212	219	238	254	273	277
		50% High Static (1) 5 hp motor	200	208	214	233	250	269	273
		100% High Static (2) 5 hp motor	217	225	231	250	266	285	289
		50% High Static (1) 7.5 hp motor	208	215	222	237	251	266	269
		100% High Static (2) 7.5 hp motor	232	240	246	265	281	300	304

NOTE - All units have a minimum Short Circuit Current Rating (SCCR) of 5000 amps.

¹ Extremes of operating range are plus and minus 10% of line voltage.

² HACR type breaker or fuse.

³ Refer to National or Canadian Electrical Code manual to determine wire, fuse and disconnect size requirements.

⁴ Factory installed circuit breaker not available.

ELECTRICAL DATA

45 TON STANDARD EFFICIENCY (R-410A)			LCH540S4						
¹ Voltage - 60hz			460V - 3 Ph						
Compressor 1	Rated Load Amps		17.9						
	Locked Rotor Amps		125						
Compressor 2	Rated Load Amps		17.9						
	Locked Rotor Amps		125						
Compressor 3	Rated Load Amps		17.9						
	Locked Rotor Amps		125						
Compressor 4	Rated Load Amps		17.9						
	Locked Rotor Amps		125						
Outdoor Fan Motors (6)	Full Load Amps		1.9						
	(total)		(11.4)						
Service Outlet 115V GFI (amps)			15						
Indoor Blower Motor	Horsepower		5	7.5	10	15	20	25	30
	Full Load Amps		7.6	11	14	21	27	34	35
² Maximum Overcurrent Protection	Unit Only		110	110	110	125	125	150	150
	Power Exhaust	50% Standard Static (1) 1 hp motor	110	110	110	125	125	150	150
		100% Standard Static (2) 1 hp motor	110	110	125	125	125	150	150
		50% High Static (1) 3 hp motor	110	110	125	125	125	150	150
		100% High Static (2) 3 hp motor	110	125	125	125	150	150	150
		50% High Static (1) 5 hp motor	110	125	125	125	150	150	150
		100% High Static (2) 5 hp motor	125	125	125	150	150	175	175
		50% High Static (1) 7.5 hp motor	125	125	125	125	150	150	150
		100% High Static (2) 7.5 hp motor	125	125	125	150	150	175	175
³ Minimum Circuit Ampacity	Unit Only		97	100	103	111	118	127	128
	Power Exhaust	50% Standard Static (1) 1 hp motor	99	103	106	113	121	130	131
		100% Standard Static (2) 1 hp motor	102	105	108	116	123	132	133
		50% High Static (1) 3 hp motor	102	105	108	116	123	132	133
		100% High Static (2) 3 hp motor	106	110	113	121	128	137	138
		50% High Static (1) 5 hp motor	104	108	111	119	126	135	136
		100% High Static (2) 5 hp motor	112	115	118	126	134	142	144
		50% High Static (1) 7.5 hp motor	108	111	114	122	129	138	139
		100% High Static (2) 7.5 hp motor	119	122	125	133	140	149	150

NOTE - All units have a minimum Short Circuit Current Rating (SCCR) of 5000 amps.

¹ Extremes of operating range are plus and minus 10% of line voltage.

² HACR type breaker or fuse.

³ Refer to National or Canadian Electrical Code manual to determine wire, fuse and disconnect size requirements.

ELECTRICAL DATA

45 TON STANDARD EFFICIENCY (R-410A)			LCH540S4						
¹ Voltage - 60hz			575V - 3 Ph						
Compressor 1	Rated Load Amps		12.8						
	Locked Rotor Amps		80						
Compressor 2	Rated Load Amps		12.8						
	Locked Rotor Amps		80						
Compressor 3	Rated Load Amps		12.8						
	Locked Rotor Amps		80						
Compressor 4	Rated Load Amps		12.8						
	Locked Rotor Amps		80						
Outdoor Fan Motors (6)	Full Load Amps (total)		1.6 (9.6)						
Service Outlet 115V GFI (amps)			20						
Indoor Blower Motor	Horsepower		5	7.5	10	15	20	25	30
	Full Load Amps		6.1	9	11	17	22	27	32
² Maximum Overcurrent Protection	Unit Only		80	80	80	100	110	110	125
	Power Exhaust	50% Standard Static (1) 1 hp motor	80	80	90	100	110	110	125
		100% Standard Static (2) 1 hp motor	80	90	90	100	110	125	125
		50% High Static (1) 3 hp motor	80	90	90	100	110	125	125
		100% High Static (2) 3 hp motor	90	90	90	100	110	125	125
		50% High Static (1) 5 hp motor	90	90	90	100	110	125	125
		100% High Static (2) 5 hp motor	90	90	100	110	110	125	125
		50% High Static (1) 7.5 hp motor	90	90	90	100	110	125	125
		100% High Static (2) 7.5 hp motor	100	100	100	110	125	125	150
³ Minimum Circuit Ampacity	Unit Only		72	74	76	84	90	96	102
	Power Exhaust	50% Standard Static (1) 1 hp motor	74	76	78	86	92	98	104
		100% Standard Static (2) 1 hp motor	76	78	80	88	94	100	106
		50% High Static (1) 3 hp motor	75	78	80	87	94	100	106
		100% High Static (2) 3 hp motor	79	82	84	91	98	104	110
		50% High Static (1) 5 hp motor	78	81	83	90	96	102	108
		100% High Static (2) 5 hp motor	84	87	89	96	102	108	114
		50% High Static (1) 7.5 hp motor	81	83	85	93	99	105	111
		100% High Static (2) 7.5 hp motor	90	92	94	102	108	114	120

NOTE - All units have a minimum Short Circuit Current Rating (SCCR) of 5000 amps.

¹ Extremes of operating range are plus and minus 10% of line voltage.

² HACR type breaker or fuse.

³ Refer to National or Canadian Electrical Code manual to determine wire, fuse and disconnect size requirements.

ELECTRICAL DATA

50 TON STANDARD EFFICIENCY (R-410A)			LCH600S4						
¹ Voltage - 60hz			208/230V - 3 Ph						
Compressor 1	Rated Load Amps		48.1						
	Locked Rotor Amps		245						
Compressor 2	Rated Load Amps		48.1						
	Locked Rotor Amps		245						
Compressor 3	Rated Load Amps		48.1						
	Locked Rotor Amps		245						
Compressor 4	Rated Load Amps		48.1						
	Locked Rotor Amps		245						
Outdoor Fan Motors (6)	Full Load Amps		4.8						
	(total)		(28.8)						
Service Outlet 115V GFI (amps)			15						
Indoor Blower Motor	Horsepower		5	7.5	10	15	20	25	30
	Full Load Amps		16.7	24.2	30.8	46.2	59.4	74.8	78
² Maximum Overcurrent Protection	Unit Only		⁴ 300	⁴ 300	⁴ 300	⁴ 300	⁴ 350	⁴ 350	⁴ 350
	Power Exhaust	50% Standard Static (1) 1 hp motor	⁴ 300	⁴ 300	⁴ 300	⁴ 300	⁴ 350	⁴ 350	⁴ 400
		100% Standard Static (2) 1 hp motor	⁴ 300	⁴ 300	⁴ 300	⁴ 300	⁴ 350	⁴ 400	⁴ 400
		50% High Static (1) 3 hp motor	⁴ 300	⁴ 300	⁴ 300	⁴ 300	⁴ 350	⁴ 400	⁴ 400
		100% High Static (2) 3 hp motor	⁴ 300	⁴ 300	⁴ 300	⁴ 350	⁴ 350	⁴ 400	⁴ 400
		50% High Static (1) 5 hp motor	⁴ 300	⁴ 300	⁴ 300	⁴ 300	⁴ 350	⁴ 400	⁴ 400
		100% High Static (2) 5 hp motor	⁴ 300	⁴ 300	⁴ 350	⁴ 350	⁴ 350	⁴ 400	⁴ 400
		50% High Static (1) 7.5 hp motor	⁴ 300	⁴ 300	⁴ 300	⁴ 350	⁴ 350	⁴ 400	⁴ 400
		100% High Static (2) 7.5 hp motor	⁴ 350	⁴ 350	⁴ 350	⁴ 350	⁴ 400	⁴ 400	⁴ 400
	³ Minimum Circuit Ampacity	Unit Only		253	260	267	282	298	317
Power Exhaust		50% Standard Static (1) 1 hp motor	258	265	272	287	303	322	326
		100% Standard Static (2) 1 hp motor	262	270	276	292	308	327	331
		50% High Static (1) 3 hp motor	263	271	277	293	309	328	332
		100% High Static (2) 3 hp motor	274	281	288	303	319	339	343
		50% High Static (1) 5 hp motor	269	277	284	299	315	334	338
		100% High Static (2) 5 hp motor	286	294	300	316	332	351	355
		50% High Static (1) 7.5 hp motor	277	284	291	306	320	335	338
		100% High Static (2) 7.5 hp motor	301	309	315	331	347	366	370

NOTE - All units have a minimum Short Circuit Current Rating (SCCR) of 5000 amps.

¹ Extremes of operating range are plus and minus 10% of line voltage.

² HACR type breaker or fuse.

³ Refer to National or Canadian Electrical Code manual to determine wire, fuse and disconnect size requirements.

⁴ Factory installed circuit breaker not available.

ELECTRICAL DATA

50 TON STANDARD EFFICIENCY (R-410A)			LCH600S4						
¹ Voltage - 60hz			460V - 3 Ph						
Compressor 1	Rated Load Amps		18.6						
	Locked Rotor Amps		125						
Compressor 2	Rated Load Amps		18.6						
	Locked Rotor Amps		125						
Compressor 3	Rated Load Amps		18.6						
	Locked Rotor Amps		125						
Compressor 4	Rated Load Amps		18.6						
	Locked Rotor Amps		125						
Outdoor Fan Motors (6)	Full Load Amps		2.4						
	(total)		(14.4)						
Service Outlet 115V GFI (amps)			15						
Indoor Blower Motor	Horsepower		5	7.5	10	15	20	25	30
	Full Load Amps		7.6	11	14	21	27	34	35
² Maximum Overcurrent Protection	Unit Only		110	110	125	125	150	150	150
	Power Exhaust	50% Standard Static (1) 1 hp motor	110	125	125	125	150	150	150
		100% Standard Static (2) 1 hp motor	125	125	125	125	150	150	150
		50% High Static (1) 3 hp motor	125	125	125	125	150	150	150
		100% High Static (2) 3 hp motor	125	125	125	150	150	175	175
		50% High Static (1) 5 hp motor	125	125	125	125	150	150	175
		100% High Static (2) 5 hp motor	125	125	125	150	150	175	175
		50% High Static (1) 7.5 hp motor	125	125	125	150	150	175	175
		100% High Static (2) 7.5 hp motor	125	150	150	150	150	175	175
³ Minimum Circuit Ampacity	Unit Only		103	106	109	117	124	133	134
	Power Exhaust	50% Standard Static (1) 1 hp motor	105	109	112	119	127	135	137
		100% Standard Static (2) 1 hp motor	108	111	114	122	129	138	139
		50% High Static (1) 3 hp motor	108	111	114	122	129	138	139
		100% High Static (2) 3 hp motor	112	116	119	126	134	143	144
		50% High Static (1) 5 hp motor	110	114	117	124	132	141	142
		100% High Static (2) 5 hp motor	118	121	124	132	139	148	149
		50% High Static (1) 7.5 hp motor	114	117	120	128	135	144	145
		100% High Static (2) 7.5 hp motor	125	128	131	139	146	155	156

NOTE - All units have a minimum Short Circuit Current Rating (SCCR) of 5000 amps.

¹ Extremes of operating range are plus and minus 10% of line voltage.

² HACR type breaker or fuse.

³ Refer to National or Canadian Electrical Code manual to determine wire, fuse and disconnect size requirements.

ELECTRICAL DATA

50 TON STANDARD EFFICIENCY (R-410A)			LCH600S4						
¹ Voltage - 60hz			575V - 3 Ph						
Compressor 1	Rated Load Amps		14.8						
	Locked Rotor Amps		100						
Compressor 2	Rated Load Amps		14.8						
	Locked Rotor Amps		100						
Compressor 3	Rated Load Amps		14.8						
	Locked Rotor Amps		100						
Compressor 4	Rated Load Amps		14.8						
	Locked Rotor Amps		100						
Outdoor Fan Motors (6)	Full Load Amps		2						
	(total)		(12)						
Service Outlet 115V GFI (amps)			20						
Indoor Blower Motor	Horsepower		5	7.5	10	15	20	25	30
	Full Load Amps		6.1	9	11	17	22	27	32
² Maximum Overcurrent Protection	Unit Only		90	90	100	110	110	125	125
	Power Exhaust	50% Standard Static (1) 1 hp motor	90	100	100	110	110	125	125
		100% Standard Static (2) 1 hp motor	100	100	100	110	125	125	125
		50% High Static (1) 3 hp motor	100	100	100	110	125	125	125
		100% High Static (2) 3 hp motor	100	100	100	110	125	125	150
		50% High Static (1) 5 hp motor	100	100	100	110	125	125	150
		100% High Static (2) 5 hp motor	100	110	110	110	125	125	150
		50% High Static (1) 7.5 hp motor	100	100	110	110	125	125	150
		100% High Static (2) 7.5 hp motor	110	110	110	125	125	150	150
³ Minimum Circuit Ampacity	Unit Only		82	85	87	94	100	106	113
	Power Exhaust	50% Standard Static (1) 1 hp motor	84	87	89	96	102	108	115
		100% Standard Static (2) 1 hp motor	86	89	91	98	104	110	117
		50% High Static (1) 3 hp motor	86	89	91	98	104	110	117
		100% High Static (2) 3 hp motor	90	93	95	102	108	114	120
		50% High Static (1) 5 hp motor	89	91	93	100	106	113	119
		100% High Static (2) 5 hp motor	95	98	100	106	112	119	125
		50% High Static (1) 7.5 hp motor	91	94	96	103	109	115	122
		100% High Static (2) 7.5 hp motor	100	103	105	112	118	124	131

NOTE - All units have a minimum Short Circuit Current Rating (SCCR) of 5000 amps.

¹ Extremes of operating range are plus and minus 10% of line voltage.

² HACR type breaker or fuse.

³ Refer to National or Canadian Electrical Code manual to determine wire, fuse and disconnect size requirements.

ELECTRICAL DATA

OPTIONAL ACCESSORIES

208/230V - 3 Ph

Optional Power Exhaust	Static Type	Standard 50%	Standard 100%	High 50%	High 100%	High 50%	High 100%	High 50%	High 100%
		Motor hp	1	1	3	3	5	5	7.5
Number of Motors		1	2	1	2	1	2	1	2
Full load amps total		4.8	9.6	10.6	21.2	16.7	33.4	24.2	48.4
Locked rotor amps total		23	46	66	132	105	210	152	304
Optional Energy Recovery Wheel (ERW)	(No.) hp	(1) 1/4							
	Full load amps	2.3							

460V - 3 Ph

Optional Power Exhaust	Static Type	Standard 50%	Standard 100%	High 50%	High 100%	High 50%	High 100%	High 50%	High 100%
		Motor hp	1	1	3	3	5	5	7.5
Number of Motors		1	2	1	2	1	2	1	2
Full load amps total		2.4	4.8	4.8	9.6	7.6	15.2	11.0	22.0
Locked rotor amps total		11.5	23	26.8	53.6	45.6	91.2	66.0	132.0
Optional Energy Recovery Wheel (ERW)	(No.) hp	(1) 1/4							
	Full load amps	1.2							

575V - 3 Ph

Optional Power Exhaust	Static Type	Standard 50%	Standard 100%	High 50%	High 100%	High 50%	High 100%	High 50%	High 100%
		Motor hp	1	1	3	3	5	5	7.5
Number of Motors		1	2	1	2	1	2	1	2
Full load amps total		2	4	3.9	7.8	6.1	12.2	9	18
Locked rotor amps total		8.9	17.8	23.4	46.8	36.6	73.2	54	108
Optional Energy Recovery Wheel (ERW)	(No.) hp	(1) 1/4							
	Full load amps	1.0							

ELECTRIC HEAT ELECTRICAL DATA

Electric Heat Size (kW)	208/230V-3 phase			460V-3 phase			575V-3 phase		
	Rated Amps	Minimum Circuit Ampacity	Maximum Overcurrent Protection (amps)	Rated Amps	Minimum Circuit Ampacity	Maximum Overcurrent Protection (amps)	Rated Amps	Minimum Circuit Ampacity	Maximum Overcurrent Protection (amps)
30	72.2	91	100	36.1	46	50	28.9	37	40
45	108.3	136	150	54.1	68	70	43.3	55	60
60	144.3	145	150	72.2	73	80	57.7	58	60
75	180.4	181	200	90.2	91	100	72.2	73	80
90	216.5	217	225	108.3	109	110	86.6	87	90
105	---	---	---	126.3	127	150	101.0	101	110
120	---	---	---	144.3	145	150	115.5	116	125
135	---	---	---	162.4	163	175	129.9	130	150
150	---	---	---	180.4	181	200	144.3	145	150
165	---	---	---	198.5	199	200	158.8	159	175
180	---	---	---	216.5	217	225	173.2	174	175

NOTE - All units have a minimum Short Circuit Current Rating (SCCR) of 5000 amps.

ELECTRIC HEAT MATCHES

- 35 ton units - 30-45-60-75-90 kW (all voltages)
- 35 ton units - 105-120 kW (460V & 575V only)
- 40 ton units - 30-45-60-75-90 kW (all voltages)
- 40 ton units - 105-120-135-150 kW (460V & 575V only)
- 45 ton units - 45-60-75-90 kW (all voltages)
- 45 ton units - 105-120-135-150-165 kW (460V & 575V only)
- 50 ton units - 45-60-75-90 kW (all voltages)
- 50 ton units - 105-120-135-150-165-180 kW (460V & 575V only)

ELECTRIC HEAT CAPACITIES

Volts Input	30 kW			45 kW			60 kW			75 kW			90 kW			105 kW		
	kW Input	Btuh Output	No. of Steps	kW Input	Btuh Output	No. of Steps	kW Input	Btuh Output	No. of Steps	kW Input	Btuh Output	No. of Steps	kW Input	Btuh Output	No. of Steps	kW Input	Btuh Output	No. of Steps
208	22.5	76,800	1	33.8	115,300	2	45.0	153,600	2	56.3	192,100	3	67.6	230,700	3	---	---	---
220	25.2	86,000	1	37.8	129,000	2	50.4	172,000	2	63.0	215,000	3	75.6	258,000	3	---	---	---
230	27.5	93,900	1	41.3	141,000	2	55.1	188,000	2	68.9	235,100	3	82.7	282,200	3	---	---	---
240	30.0	102,400	1	45.0	153,600	2	60.0	204,800	2	75.0	255,900	3	90.0	307,100	3	---	---	---
440	25.2	86,000	1	37.8	129,000	2	50.4	172,000	2	63.0	215,000	3	75.6	258,000	3	88.2	301,000	4
460	27.5	93,900	1	41.3	141,000	2	55.1	188,000	2	68.9	235,100	3	82.7	282,200	3	96.4	329,000	4
480	30.0	102,400	1	45.0	153,600	2	60.0	204,800	2	75.0	255,900	3	90.0	307,100	3	105.0	358,300	4
550	25.2	86,000	1	37.8	129,000	2	50.4	172,000	2	63.0	215,000	3	75.6	258,000	3	88.2	301,000	4
575	27.5	93,900	1	41.3	141,000	2	55.1	188,000	2	68.9	235,100	3	82.7	282,200	3	96.4	329,000	4
600	30.0	102,400	1	45.0	153,600	2	60.0	204,800	2	75.0	255,900	3	90.0	307,100	3	105.0	358,300	4

ELECTRIC HEAT CAPACITIES

Volts Input	120 kW			135 kW			150 kW			165 kW			180 kW		
	kW Input	Btuh Output	No. of Steps	kW Input	Btuh Output	No. of Steps	kW Input	Btuh Output	No. of Steps	kW Input	Btuh Output	No. of Steps	kW Input	Btuh Output	No. of Steps
440	100.8	344,000	4	113.4	386,900	4	126.0	430,000	4	138.6	473,000	4	151.2	516,000	4
460	110.2	376,100	4	124.0	423,100	4	137.7	469,900	4	151.5	517,000	4	165.2	563,700	4
480	120.0	409,500	4	135.0	460,700	4	150.0	511,900	4	165.0	563,100	4	180.0	614,200	4
550	100.8	344,000	4	113.4	386,900	4	126.0	430,000	4	138.6	473,000	4	151.2	516,000	4
575	110.2	376,100	4	124.0	423,100	4	137.7	469,900	4	151.5	517,000	4	165.2	563,700	4
600	120.0	409,500	4	135.0	460,700	4	150.0	511,900	4	165.0	563,100	4	180.0	614,200	4

BLOWER DRIVE COMPONENT MANUFACTURER'S NUMBERS

Drive No.	DRIVE COMPONENTS							
	MOTOR PULLEY		BLOWER PULLEY		BLOWER BUSHING		BELTS	
	OEM Part No.	Browning No.	OEM Part No.	Browning No.	OEM Part No.	Browning No.	OEM Part No.	Browning No.
1	P-8-2237	1VP62 X 1-1/8	78M9001	1B5V160	79M0601	B - 1-11/16	78M6401	5VX900
2	100239-03	1VP65 X 1-1/8	78M8901	1B5V154	79M0601	B - 1-11/16	78M6401	5VX900
3	78M7101	1VP65 X 1-3/8	78M9001	1B5V160	79M0601	B - 1-11/16	78M6401	5VX900
4	78M7001	1VP62 X 1-3/8	78M8701	1B5V124	79M0601	B - 1-11/16	78M5901	5VX830
5	78M5601	1VP71 X 1-3/8	78M8901	1B5V154	79M0601	B - 1-11/16	78M6401	5VX900
6	78L5601	1VP71 X 1-3/8	78M8801	1B5V136	79M0601	B - 1-11/16	78M6201	5VX860
7	78M7201	1VP62 X 1-5/8	78M8801	1B5V136	79M0601	B - 1-11/16	78M6001	5VX840
8	78M7401	1VP75 X 1-5/8	78M8701	1B5V124	79M0601	B - 1-11/16	78M5901	5VX830
9	78M7501	2VP71 X 1-5/8	79M0001	2B5V124	79M0601	B - 1-11/16	78M5901	5VX830
10	78M7601	2VP75 X 1-5/8	78M9901	2B5V110	79M0601	B - 1-11/16	78M5701	5VX800
11	78L7701	2V58B70 X 1-7/8	79M0001	2B5V124	79M0601	B - 1-11/16	78M5801	5VX810
12	78M7801	2V68B80 X 1-7/8	79M0001	2B5V124	79M0601	B - 1-11/16	78M5901	5VX830
13	78M7701	2V58B70 X 1-7/8	78M9901	2B5V110	79M0601	B - 1-11/16	78M5701	5VX800
14	78M7701	2V58B70 X 1-7/8	79M0201	2Q5V103	79M0801	Q - 1-11/16	78M5601	5VX780

POWER EXHAUST DRIVE COMPONENT MANUFACTURER'S NUMBERS

Drive No.	DRIVE COMPONENTS					
	MOTOR PULLEY		BLOWER PULLEY		BELTS	
	Browning No.	OEM Part No.	Browning No.	OEM Part No.	Browning No.	OEM Part No.
1A	1VP60 x 1 3/8	78L5501	BK100 x 1 7/16	39L1301	BX68	88K3401
1B	1VP60 x 1 3/8	78L5501	BK100 x 1 7/16	39L1301	BX62	57A7701
2A	1VP60 x 1 3/8	78L5501	BK110 x 1 7/16	81M0401	BX70	31K9601
2B	1VP60 x 1 3/8	78L5501	BK110 x 1 7/16	81M0401	BX64	24L5001
3A	1VP56 x 1 1/8	P-8-1492	BK100 x 1 7/16	39L1301	BX68	88K3401
3B	1VP56 x 1 1/8	P-8-1492	BK100 x 1 7/16	39L1301	BX61	93J9801
4A	1VP60 x 1 1/8	41C1301	BK115 x 1 7/16	81M0501	BX71	31K9701
4B	1VP60 x 1 1/8	41C1301	BK115 x 1 7/16	81M0501	BX64	24L5001
5A	1VP56 x 7/8	P-8-1494	BK115 x 1 7/16	81M0501	BX71	31K9701
5B	1VP56 x 7/8	P-8-1494	BK115 x 1 7/16	81M0501	BX64	24L5001
6A	1VP60 x 7/8	80K5501	BK115 x 1 7/16	81M0501	BX71	31K9701
6B	1VP60 x 7/8	80K5501	BK115 x 1 7/16	81M0501	BX64	24L5001

NOTE - A drives for rear blower assembly; B drives for front blower assembly.

LGH/LCH PARTS ARRANGEMENT

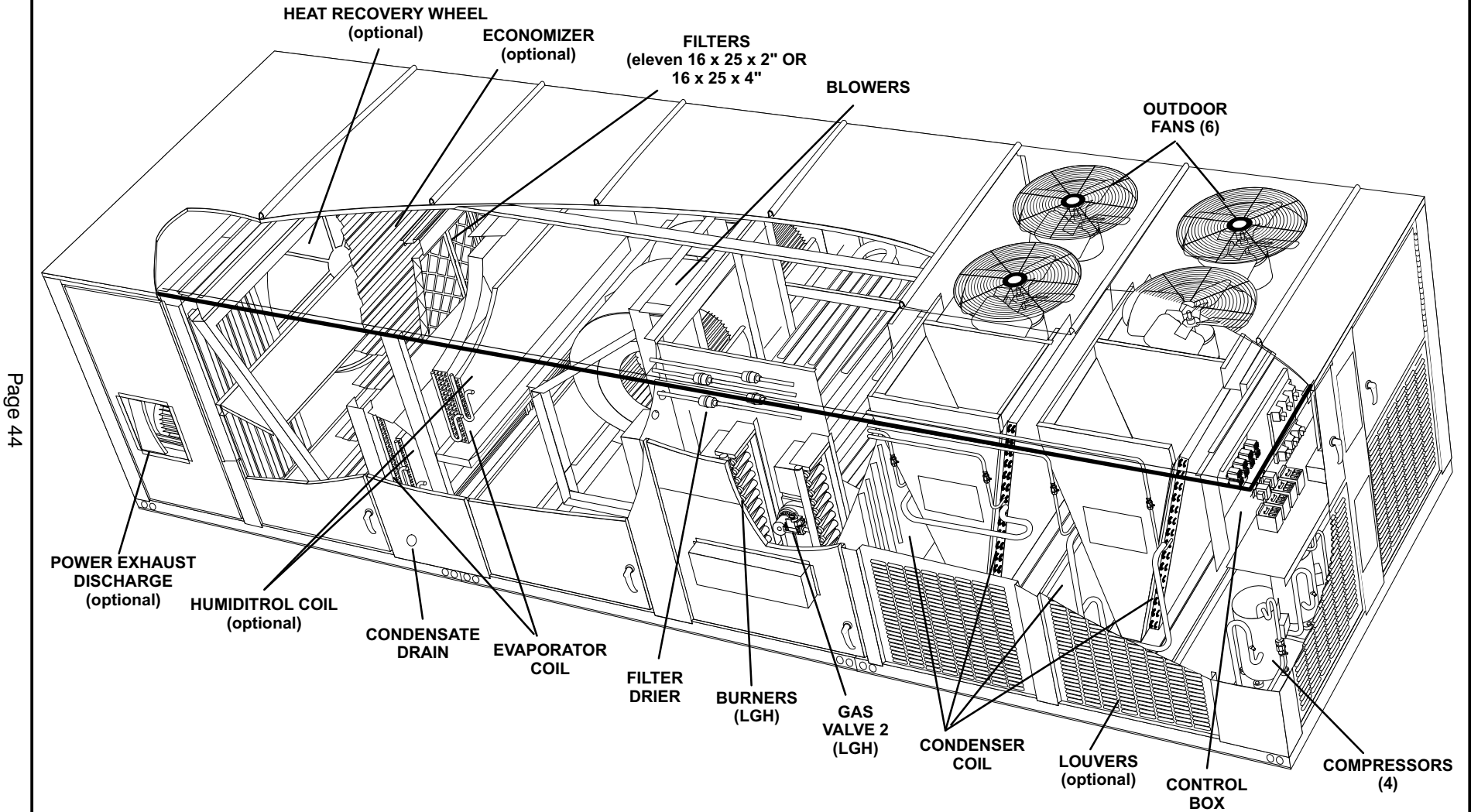
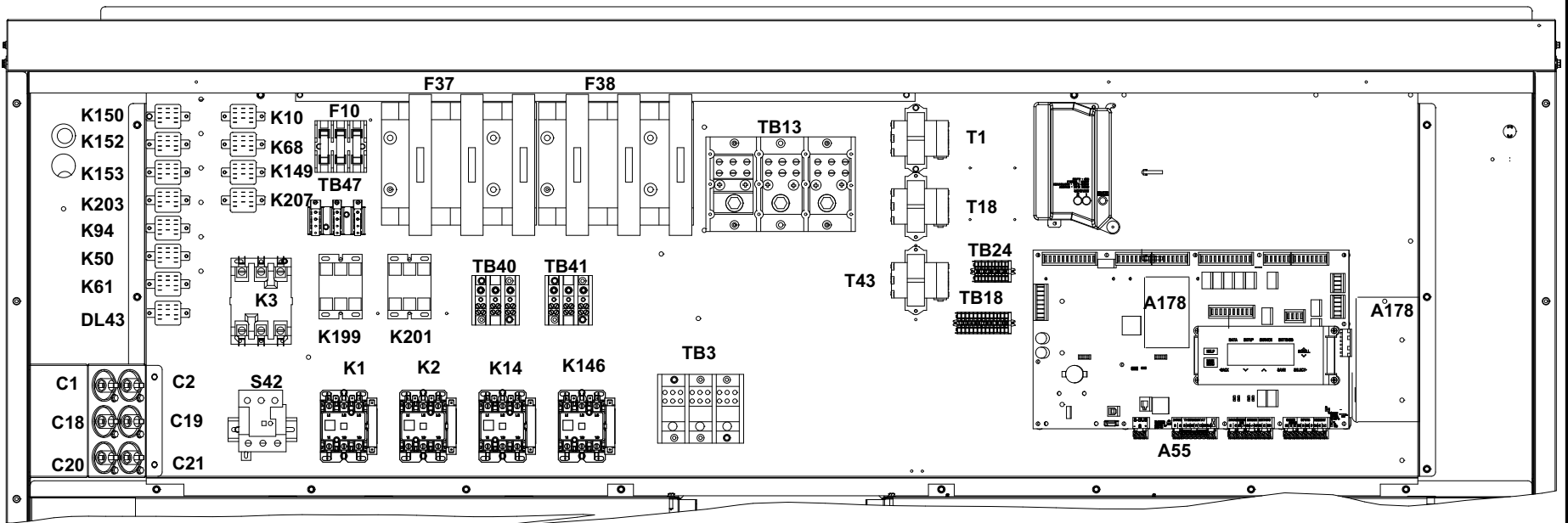

FIGURE 1

LGH/LCH CONTROL BOX PARTS ARRANGEMENT



Page 45

A55 - UNIT CONTROLLER
A178 - C3 CONTROLLER
A187 - GENERAL PURPOSE
C1 - CAP. OUTDOOR FAN 1
C2 - CAP. OUTDOOR FAN 2
C18 - CAP. OUTDOOR FAN 3
C19 - CAP. OUTDOOR FAN 4
C20 - CAP. OUTDOOR FAN 5
C21 - CAP. OUTDOOR FAN 6
DL43 - DELAY, CYCLE TIMER
F10 - FUSE OUTDOOR FAN MOTOR
F37 - FUSE (Y VOLTAGE)
F38 - FUSE (Y VOLTAGE)
K1 - CONTACTOR COMPRESSOR 1

K2 - CONTACTOR COMPRESSOR 2
K3 - BLOWER CONTACTOR
K10 - RELAY OUTDOOR FAN 1
K14 - CONTACTOR COMPRESSOR 3
K50 - RELAY DESICCANT WHEEL
K61 - RELAY DESICCANT WHEEL
K68 - RELAY OUTDOOR FAN 2
K94 - RELAY DESICCANT WHEEL
K146 - CONTACTOR COMPRESSOR 4
K149 - RELAY OUTDOOR FAN 3
K150 - RELAY OUTDOOR FAN 4
K152 - RELAY OUTDOOR FAN 5
K153 - RELAY OUTDOOR FAN
K199 - CONTACTOR EXHAUST BLOWER 1

K201 - CONTACTOR EXHAUST BLOWER 2
K203 - RELAY INVERTER BLOWER
K207 - RELAY INVERTER EXHAUST BLOWER
S42 - BLOWER OVERLOAD RELAY
T1 - TRANSFORMER CONTROL
T18 - TRANSFORMER CONTACTOR
T43 - TRANSFORMER HUMIDITROL
TB3 - TERMINAL BLOCK ELECTRIC HEAT
TB13 - TERMINAL BLOCK SUB-FUSE
TB18 - TERMINAL STRIP INVERTER

TB24 - TERMINAL STRIP COMMON
TB40 - TERMINAL STRIP COMP 1
TB41 - TERMINAL STRIP COMP 2
TB47 - TERMINAL STRIP EXHAUST FANS

FIGURE 2

I-UNIT COMPONENTS

ELECTROSTATIC DISCHARGE (ESD) Precautions and Procedures

⚠ CAUTION

Electrostatic discharge can affect electronic components. Take precautions during installation and service to protect the unit's electronic controls. Precautions will help to avoid control exposure to electrostatic discharge by putting the unit, the control and the technician at the same electrostatic potential. Neutralize electrostatic charge by touching hand and all tools on an unpainted unit surface, such as the gas valve or blower deck, before performing any service procedure.

LGH/LCH units are configured to order units (CTO). All units come standard with hinged unit panels. The unit panels may be held open with the door rod located inside the unit.

A-Control Box Components

Control box components are shown in figure 2, The control box is located above the compressor compartment.

1-Disconnect Switch S48

All units may be equipped with an optional disconnect switch S48. S48 is a switch which can be used by the service technician to disconnect power to the unit.

NOTE - S48 is not an over current protection switch. If unit is equipped with S48 other means of over current protection must be used.

2-Control Transformer T1

All units use a T1 line voltage to 24VAC transformer mounted in the control box. Transformer supplies power to control circuits in the unit. The transformer is rated at 90VA and is protected by a 6 amp circuit breaker (CB8). The 208/230 (Y) voltage transformer has two primary

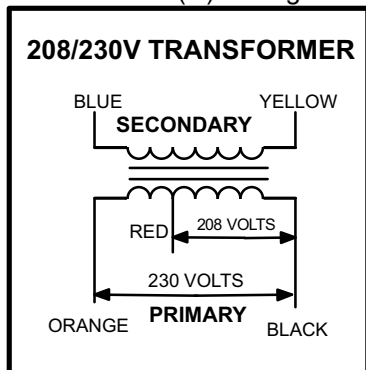

FIGURE 3

voltage taps as shown in figure 3. Units will be factory wired for 230V (orange and black). 208V (red and black) applications must be re-wired in the field.

3-Contactor Transformer T18

T18 is a single line voltage to 24VAC transformer used in all units. Transformer T18 is rated at 90VA and protected by a 6 amp circuit breaker (CB18). The transformer supplies 24VAC power to the contactors.

4-Humiditrol Transformer T43

T43 is a single line voltage to 24VAC transformer used on optional Humiditrol units. Transformer T43 is rated at 70VA and is protected by a 3.5 amp circuit breaker (CB8). The transformer supplies 24VAC power to the reheat solenoid valves.

5-Terminal Strips TB18 and TB24

TB18 is used any time power exhaust or modulating gas heat is installed in the unit. It is also used in VAV applications. TB24 is common on all units. See unit wiring diagram.

6-Terminal Blocks TB2, TB13, TB25, TB40, TB41 and TB47

All L1, L2 and L3 wiring is color coded; L1 is red, L2 is yellow and L3 is blue. TB40 distributes line voltage to compressor B1 through contactors K1 and to inverter A96. TB40 also distributes line voltage to optional power exhaust blowers B35, B36 through contactors K199, K201. TB41 distributes line voltage to compressors B2, B13 and B20 through contactors K2, K14 and K146. TB47 distributes line voltage to condenser fans B4, B5, B21, B22, B23 and B24 through relays K10, K68, K149, K150, K152 and K153. TB2 and TB13 are single point power installations only and distribute line voltage power to unit line voltage components. TB25 distributes line voltage power to the blower motor B3. See unit wiring diagram.

7-Outdoor Fan Motor Fuse Block & Fuses F10 (all units)

Three line voltage, F10 fuses provide overcurrent protection to all condenser fans in all units. The fuses are rated at 40A in three phase, 208/230V applications. All others use 30A fuses.

8-Fuses F37 and F38 (Y volt and G, J volt with electric heat)

Three line voltage fuses F37 provide overcurrent protection for compressor B1, blower B3 and optional exhaust blower B35 and B36. Three line voltage fuses F38 provide overcurrent protection for compressor B2, B13 and B20.

9-Outdoor Fan Capacitors C1, C2, C18, C19, C20, C21 (single phase motors only)

Fan capacitors C1, C2, C18, C19, C20 and C21 are used to assist in the start up of condenser fans B4, B5, B21, B22, B23 and B24 respectively. Ratings will be on condenser fan motor nameplate or see side of capacitor.

10-Compressor Contactor K1, K2, K14 & K146

All compressor contactors are three-pole double-break contactors with a 24VAC coil. In all LGH/LCH units, K1 (energized by A55), K2 (energized by A55), K14 (energized by A178) and K146 (energized by A178) controls compressors B1, B2, B13 and B20 respectively in response to cooling demands.

11-Blower Bypass Contactors K3 & K202

Blower contactors K3 and K202, used in bypass units, are three-pole double-break contactors with a 24VAC coil used to energize the indoor blower motor B3 in response to blower demand. K202 or K3 is energized by A55 Unit Controller.

12-Outdoor Fan Relay K10, K68, K149, K150, K152, K153 (all units)

Outdoor fan relays K10, K68, K149, K150, K152 and K153 are DPDT in single phase units and 3PDT in three phase units. All have 24VAC coils. In all units, K10 (energized by A55), K68 (energized by A55), K149, K150, K152 and K153 (energized by A178) controls condenser fans B4 (fan 1), B5 (fan 2), B21 (fan 3), B22 (fan 4), B23 (fan 5) and B24 (fan 6) respectively, in response to cooling demand.

13-Burner Controls A3 & A12 (LGH units)

All LGH units have two burner controls. A3 controls gas heat section one, while A12 controls gas heat section two. The first gas heat section and the second gas heat section burner controls are identical. Both burner controls are factory set and are not adjustable. The control makes three attempts at ignition and then locks out the system if ignition is not obtained after the third trial. Reset after lockout requires only breaking and remaking thermostat demand. The control shuts off gas flow immediately in the event of a gas or power failure. Upon restoration of gas and power, the control will restart the ignition sequence and continue until flame is established or system locks out. For a more detailed description see the Gas Heat Components section.

14-Power Exhaust Contactors K199 & K201

Contactors K199 and K201 are N.O. DPDT contactors with a 24VAC coil. K199, K201 are used in all units equipped with optional power exhaust less inverters. When K199 and K201 close, the exhaust blowers B35 and B36 are energized.

15-Blower Motor Overload Relay S42

Relay S42 is located in the control box and is connected in line with the blower motor to monitor the current flow to the motor. When the relay senses an overload condition, a set of normally closed contacts open to de-energize DI-2 P299-4 of the A55 Unit Controller. A55 de-energizes all outputs.

16-Desiccant Wheel Relays K50, K61, K94

Desiccant wheel relays K50 and K61 are SPDT relays and K94 is a 3PDT relay. All have a 24VAC coil. Relays are used in all units equipped with optional desiccant wheel.

17-Supply Blower Auxiliary Relay K203

Blower relay K203, used in all VFD units, is a 24VAC single pole relay used to energize the B3 indoor blower motor in response to blower demand. K203 is energized by the A55 Unit Controller.

18-Exhaust Blower Auxiliary Relay K207

Power exhaust K207 is used in optional variable speed power exhaust. K207 is used to energize the exhaust blowers B35 and B36 in response to exhaust demand. K207 is energized by the A55 Unit Controller.

UNIT CONTROL BOARDS

Units are equipped with a series of control boards which integrates most control functions required for the LGH/LCH units. The control boards are located in the lower right hand corner of the control box. The control includes complete unit diagnostics with permanent code storage, field programmable control parameters and control options, on-site testing and serial communications. Several different printed circuit boards (see figure 4) make-up the modular configurations for the LGH/LCH units. See figure 4 for control location. For further information refer to the Unit Controller manual sent with each unit.

19-Unit Controller A55 (all units)

The A55 Unit Controller is the heart of the system. It controls two compressors, two two-stage gas valves or two banks of electric heat, one outdoor fan and one blower. A55 includes the thermostat inputs, serial communications ports, diagnostic code display, control pushbutton, system configuration dip switches and four expansion ports.

20-General Purpose GP3 Module A187

The GP3 Board communicates with the A55 board to control the Modulating Gas Valves (MGV) and Power Exhaust operation. Dip switches 1 & 2 should be set to off, off for regular operation of MGV and P.E.

21-Compressor 3 & 4 Control Module A178 (all units)

The compressor 3 & 4 control module A178 controls two additional compressor stages for the LGH/LCH units. A178 includes all inputs and outputs required for compressor and fan control, compressor stage diagnostics and low ambient control. A178 also controls outputs for second stage heating operation.

CONTROLLER INPUTS AND OUTPUTS

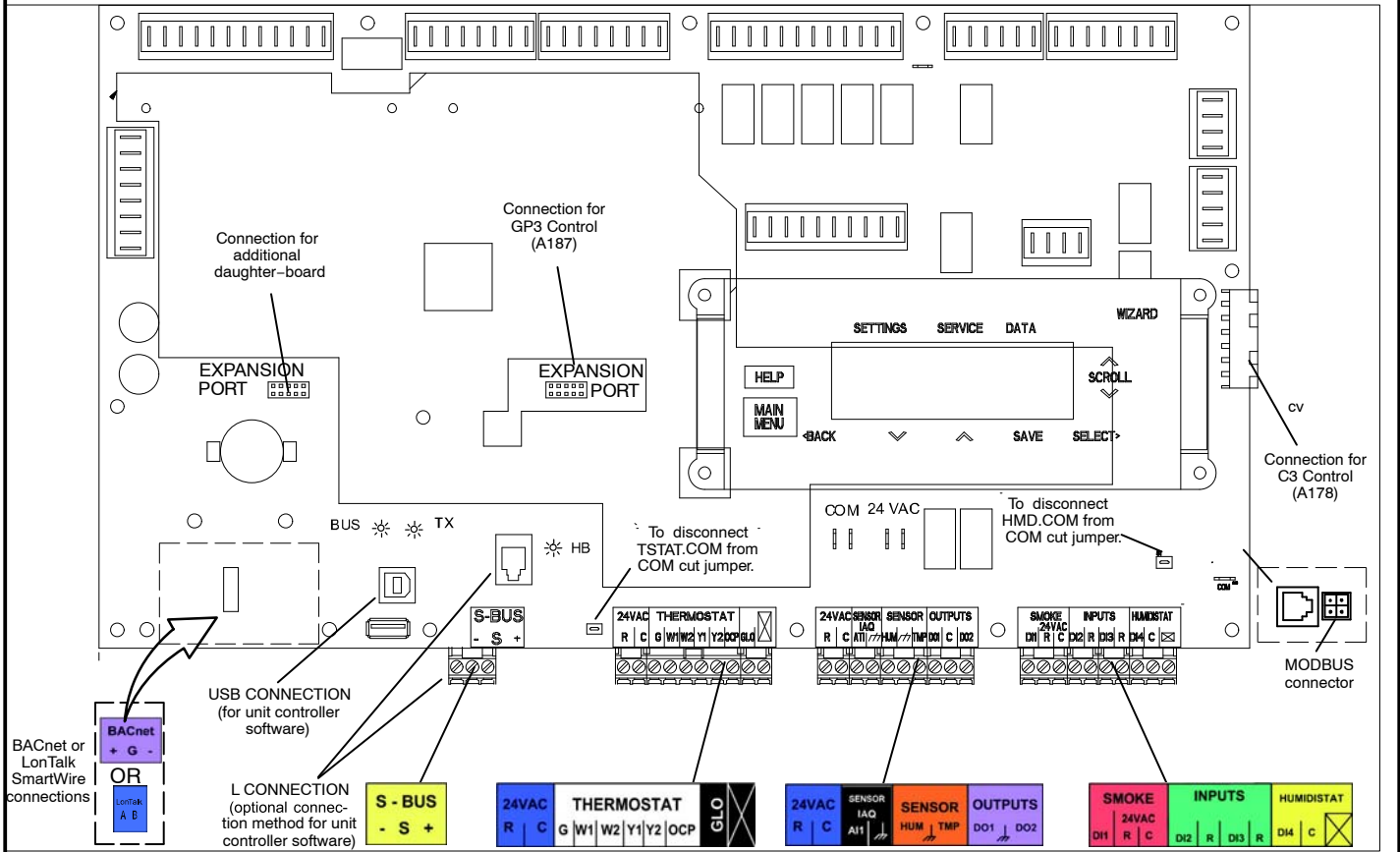
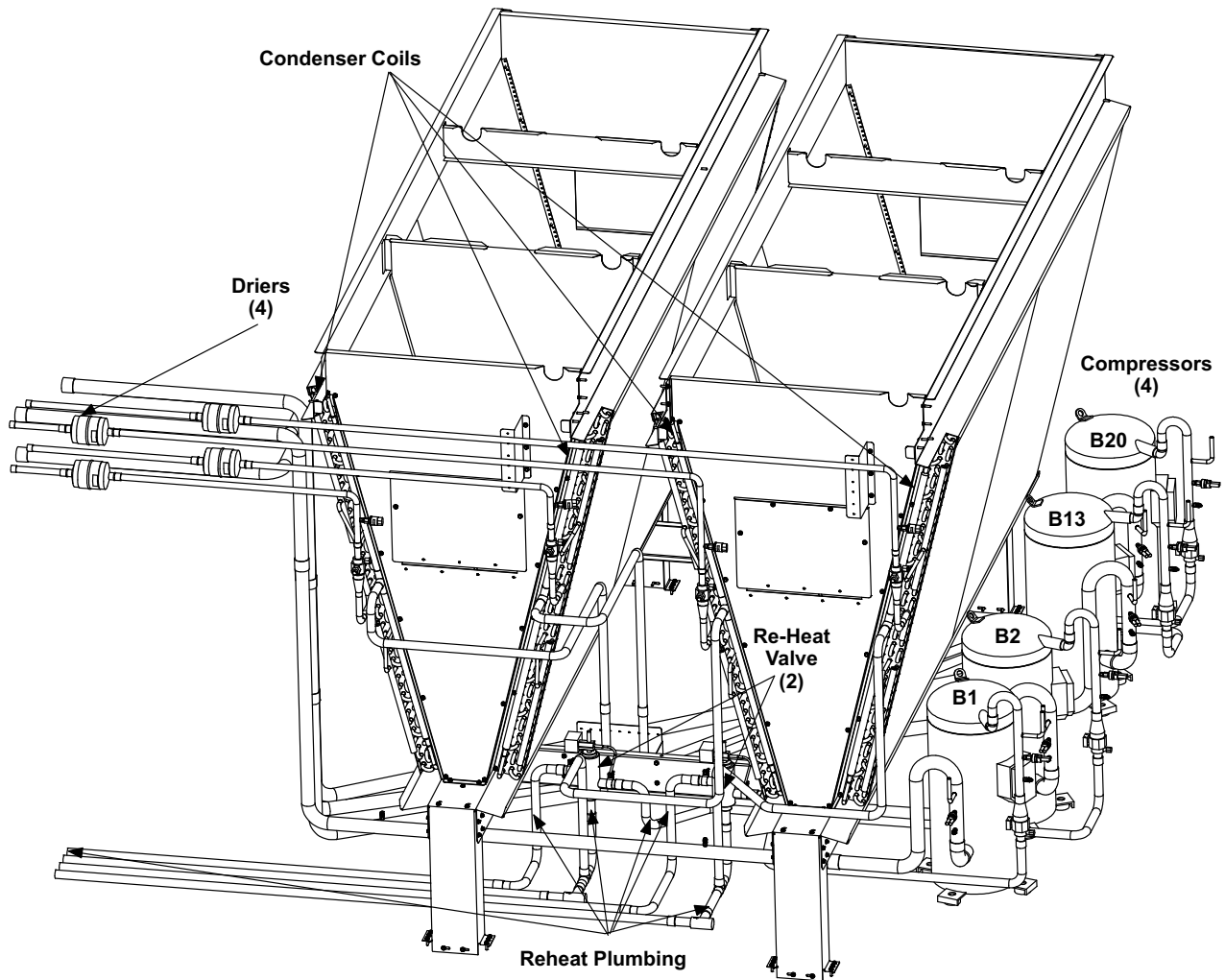

FIGURE 4

LGH/LCH CONDENSER PLUMBING (shown with reheat plumbing)



COMPRESSOR DETAIL

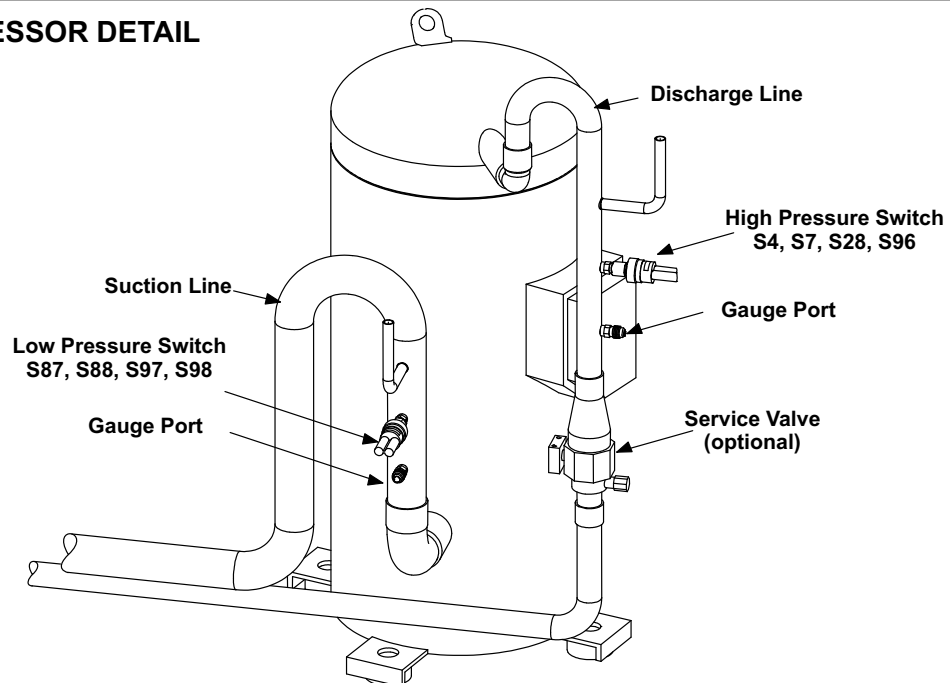

FIGURE 5

LGH/LCH EVAPORATOR PLUMBING MSAV with Re-Heat

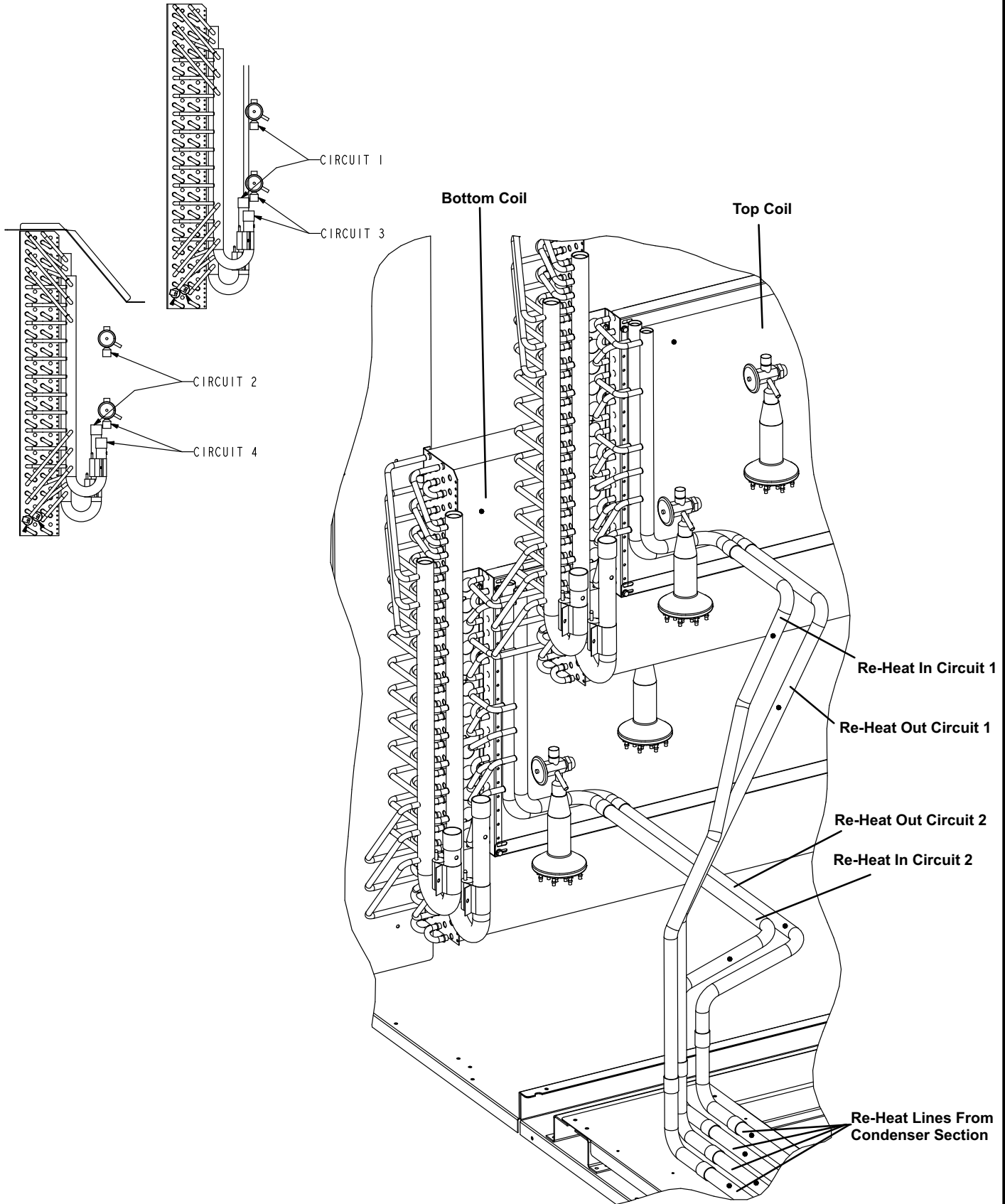

FIGURE 6

LGH/LCH EVAPORATOR PLUMBING VAV and MSAV

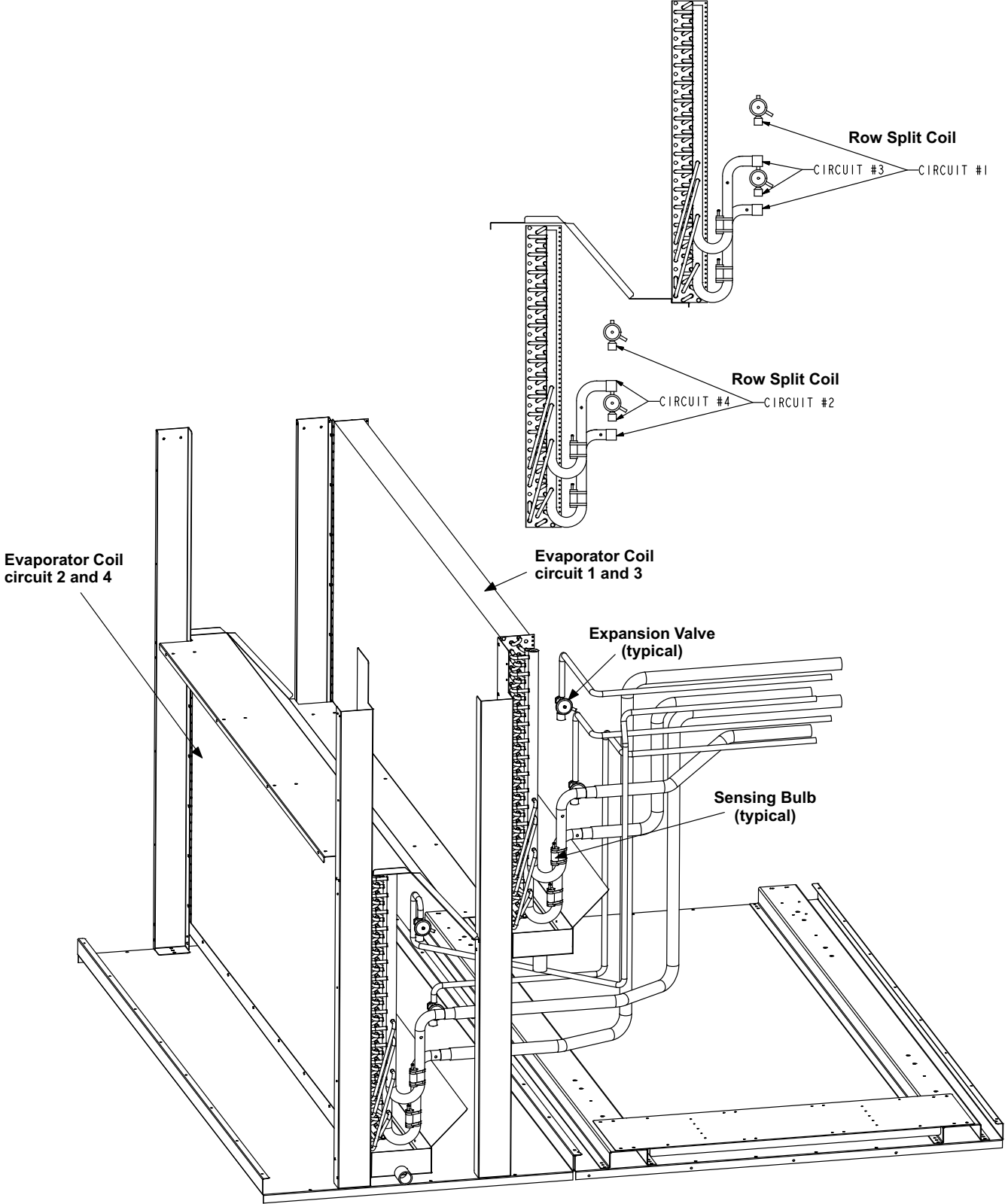

FIGURE 7

B-Cooling Components

All units use independent cooling circuits consisting of separate compressors, condenser coils and evaporator coils. See figures 5, 6 and 7. Six draw-through type condenser fans are used in all units. All units are equipped with belt-drive blowers which draw air across the evaporator during unit operation.

Cooling may be supplemented by a factory installed economizer. Evaporators on all units are row split and are stacked. See figures 6 and 7 for more detail. Each evaporator uses a thermostatic expansion valve as the primary expansion device. Each evaporator is also equipped with enhanced fins and rifled tubing. In all units, each compressor is protected by a crankcase heater, high pressure switch and low pressure switch. Additional protection is provided by low ambient switches and freezestats (on each evaporator).

1-Compressors B1, B2, B13 & B20

All units use scroll compressors and are equipped with independent cooling circuits. The capacity of each compressor is added to reach the total capacity of the unit. Compressor electrical specifications can be found in the SPECIFICATIONS section in this manual.

WARNING

Electrical shock hazard. Compressor must be grounded. Do not operate without protective cover over terminals. Disconnect power before removing protective cover. Failure to follow these precautions could cause electrical shock resulting in injury or death.

Each compressor is energized by a corresponding compressor contactor.

NOTE-Refer to the wiring diagram section for specific unit operation.

2-Crankcase Heaters HR1, HR2, HR5 & HR11

All units use belly-band type crankcase heaters. Heater HR1 is installed around compressor B1, heater HR2 compressor B2, HR5 compressor B13 and HR11 compressor B20.

3-High Pressure Switches S4, S7, S28 & S96

The high pressure switch is an auto-reset SPST N.C. switch which opens on a pressure rise. All units are equipped with this switch. The switch is located in the compressor discharge line and is wired in series with the compressor contactor coil.

S4 (first circuit), S7 (second circuit), S28 (third circuit) and S96 (fourth circuit) are wired in series with the respective compressor contactor coils.

A55 Unit Controller has a three-strike counter before locking out the particular compressor circuit. This means the control allows three high pressure trips per one cooling-demand. The control can be reset by breaking and remaking the cooling demand.

When discharge pressure rises to 640 ± 10 psig (4413 ± 69 kPa) (indicating a problem in the system) the switch opens and the respective compressor is de-energized (the economizer can continue to operate). When discharge pressure drops to 475 ± 20 psig (3275 ± 138 kPa) the pressure switch will close.

4-Low Ambient Switches S11, S84, S85 & S94

The low ambient switch is an auto-reset SPST N.O. pressure switch which allows for mechanical cooling operation at low outdoor temperatures. All units are equipped with this switch. In all models a switch is located in each liquid line prior to the indoor coil section.

In the LGH/LCH units S11 (compressor one), S84 (compressor two) are wired in parallel, to the outdoor fan relay K149 while S85 (compressor three) and S94 (compressor four) are in parallel, wired to outdoor fan relay K150.

Units charged with R-410A

When liquid pressure rises to 450 ± 10 psig (3102 ± 69 kPa), the switch closes and the condenser fans for that circuit are energized. When discharge pressure in one refrigerant circuit drops to 240 ± 10 psig (1655 ± 69 kPa), the switch opens and the condenser fan in that refrigerant circuit is de-energized. This intermittent fan operation results in higher condensing temperature allowing the system to operate without losing capacity.

5-Low Pressure Switches S87, S88, S97 & S98

The low pressure switch is an auto-reset SPST N.O. switch (held N.C. by refrigerant pressure) which opens on a pressure drop. All units are equipped with this switch. The switch is located in the compressor suction line.

S87 (compressor one), S88 (compressor two), S98 (compressor three) and S97 (compressor four) are wired in series with the A55 Unit Controller.

The Unit Controller governs the low pressure switches by shunting the switches during start up until pressure is stabilized. After the shunt period, the control has a three-strike counter, during each cooling demand, before the compressor is locked out. The control is reset by breaking and remaking the cooling demand.

NOTE - Shunt time period varies according to compressor off time and the outdoor temperature. Refer to Integrated Modular Control Guide sent with each unit.

When suction pressure drops to 40 ± 5 psig (276 ± 34 kPa) (indicating low pressure), the switch opens and the compressor is de-energized. The switch automatically resets when pressure in the suction line rises to 90 ± 5 psig (620 ± 34 kPa).

6-Service Valve (optional all units)

Units may be equipped with service valves located in the discharge and liquid lines. The service valves are manually operated valves used for service operation.

7-Filter Drier (all units)

All units have a filter drier located in the liquid line of each refrigerant circuit behind the panel above the heat section. The drier removes contaminants and moisture from the system.

8-Freezestats S49, S50, S53 & S95

Each unit is equipped with a low temperature switch (freezestat) located on the return bend of each evaporator coil. S49 (first circuit), S50 (second circuit), S53 (third circuit) and S95 (fourth circuit) are located on the corresponding evaporator coils.

Each freezestat is wired to the A55 Unit Controller. Each freezestat is a SPST N.C. auto-reset switch which opens at $29^{\circ}\text{F} \pm 3^{\circ}\text{F}$ ($-1.7^{\circ}\text{C} \pm 1.7^{\circ}\text{C}$) on a temperature drop and closes at $58^{\circ}\text{F} \pm 4^{\circ}\text{F}$ ($14.4^{\circ}\text{C} \pm 2.2^{\circ}\text{C}$) on a temperature rise. To prevent coil icing, freezestats open during compressor operation to temporarily disable the respective compressor until the coil warms sufficiently to melt any accumulated frost.

A55 Unit Controller has a three-strike counter before locking out the particular compressor circuit. This means the control allows three freezestat trips per one cooling demand. The control can be reset by breaking and remaking the cooling demand.

If the freezestats are tripping frequently due to coil icing, check the unit charge, airflow and filters before allowing unit back in operation. Make sure to eliminate conditions which might promote evaporator ice buildup.

9-Condenser Fans B4, B5, B21, B22, B23 & B24

See Specifications section in this manual for specifications of condenser fans used in LGH/LCH units. All units are equipped with six condenser fans. The complete fan assembly may be removed for servicing and cleaning. See steps below. Reverse order when reassembling. See figure 8.

- 1 - Unscrew 6 fan grill screws and remove grill.
 - 2 - Loosen fan blade hub set screw and slide fan off motor shaft.
 - 3 - Loosen motor bracket bolt.
 - 4 - Disconnect motor wire jack/plug and remove motor.
- Motor and fan blades can now be serviced.

Condenser Fan Removal and Operation

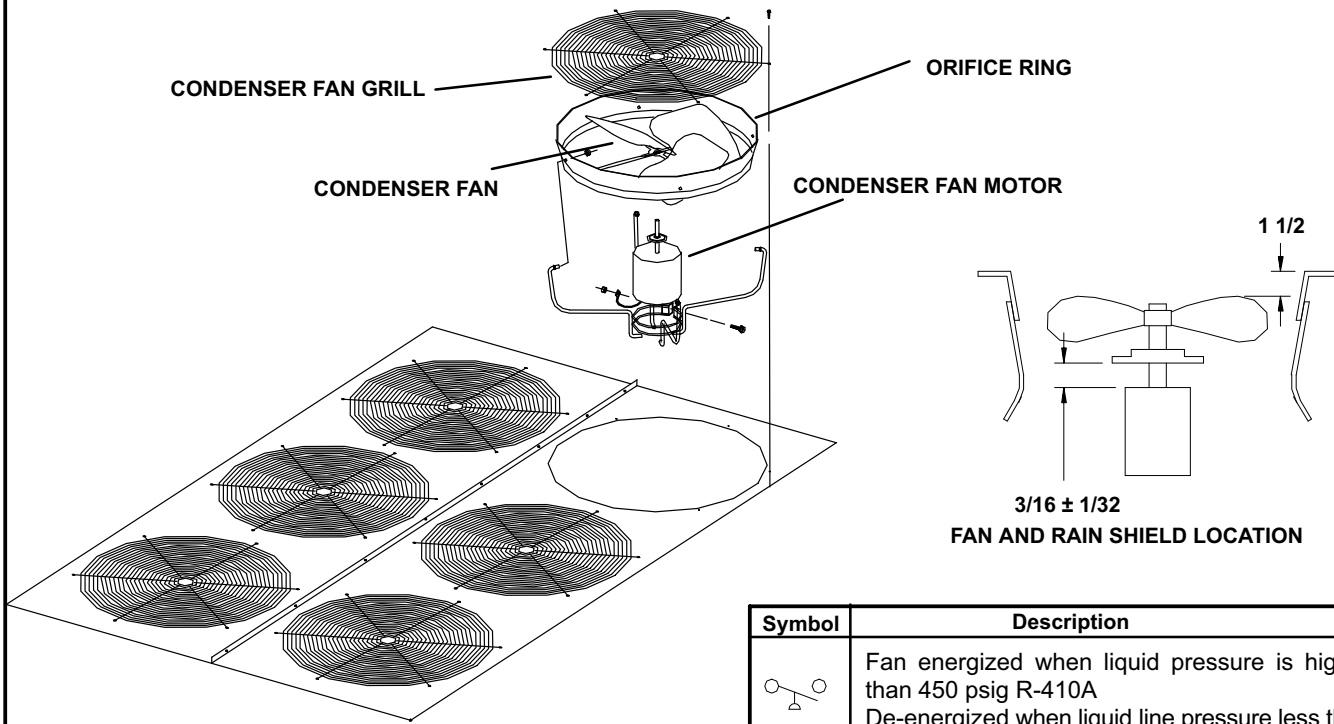

Symbol	Description
	Fan energized when liquid pressure is higher than 450 psig R-410A De-energized when liquid line pressure less than 240 psig R-410A.
55°F	A55 (TP2) De-energizes fan below 55°F/13°C
40°F	A55 (TP1) De-energizes fan below 40°F/4.4°C
	A55 delays the fan 2 seconds after thermostat demand

1 A55 de-energizes all compressors below 0°F (-18°C) .
2 Multiple low ambient switches on same fan must all be open to de-energize fan.

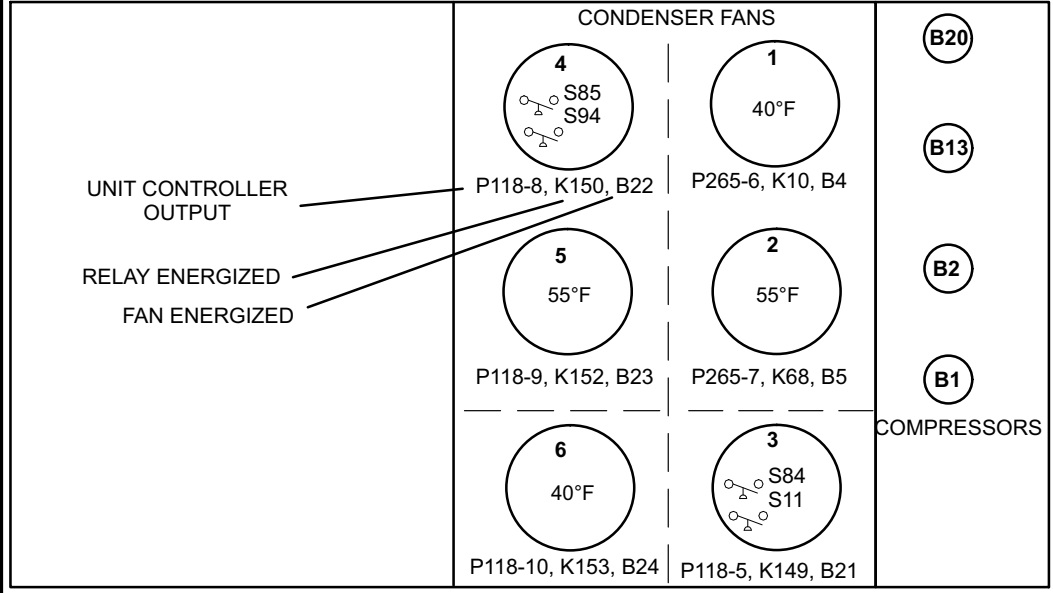

FIGURE 8

C-Blower Compartment

The blower compartment in all units is located between the evaporator coil and the heat section.

1-Blower Wheels (all units)

All units have two 20 in. x 15 in. (508 mm x 381 mm) blower wheels. Both wheels are driven by one motor.

2-Indoor Blower Motor B3 (all units)

All units use three-phase single-speed blower motors. CFM adjustments are made by adjusting the motor pulley (sheave). Motors are equipped with sealed ball bearings. All motor specifications are listed in the SPECIFICATIONS section in this manual. Units may be equipped with motors manufactured by various manufacturers, therefore electrical FLA and LRA specifications will vary. See unit rating plate for information specific to your unit.

OPERATION / ADJUSTMENT

Initiate blower demand at thermostat according to instructions provided with thermostat. Unit will cycle on thermostat demand. The following steps apply to applications using a typical electro-mechanical thermostat.

- 1- Blower operation is manually set at the thermostat sub-base fan switch. With fan switch in **ON** position, blowers will operate continuously.
- 2- With fan switch in **AUTO** position, the blowers will cycle with demand.

In zone sensor applications the blower will cycle with demand (default). For continuous blower operation refer to the Unit Controller manual.

Determining Supply CFM

- 1- The following measurements must be made with a dry indoor coil. Run blower without a cooling demand. Air filters must be in place when measurements are taken.
- 2- Set the VFD to 60Hz by referring to the Unit Controller manual provided with unit.
- 3- Measure the indoor blower shaft RPM.
- 4- With all access panels in place, measure static pressure external to unit (from supply to return).
- 5- Referring to blower data in the front of this manual, use static pressure and RPM readings to determine unit CFM.
- 6- The blower RPM can be adjusted at the motor pulley. Loosen Allen screw and turn adjustable pulley clockwise to increase CFM. Turn counterclockwise to decrease CFM. See figure 9 and 10.

Loosen both Allen screws on units equipped with two belts. Remove the key and turn the inner sheave the opposite direction of the outer sheave. Replace the key before securing Allen screws.

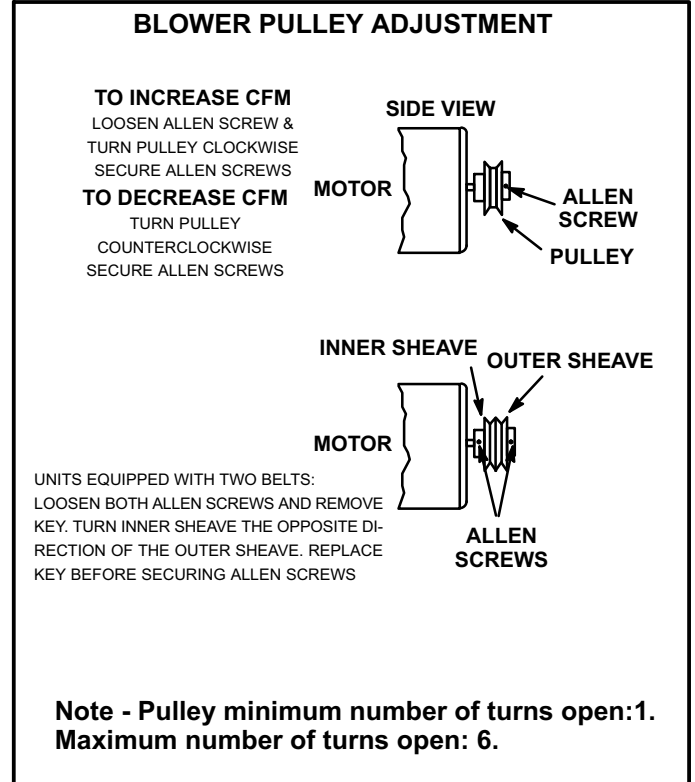

FIGURE 9

7- Supply Air Blowers With VFD -

In addition to adjusting the motor pulley, the supply CFM can be adjusted at the Unit Controller.

The default maximum blower output is (100% or 60Hz). To decrease the blower CFM output through the Unit Controller, adjust Parameter 49 for VAV units and Parameter 12 for MSAV units.

The default minimum blower output is 33% (20Hz). Refer to parameter 27 and 28 to adjust the VFD minimum output.

Optional Power Exhaust Blowers

- 1- Determine the power exhaust CFM in the same manner as the supply CFM with one exception: measure the return duct static pressure instead of total external pressure. See power exhaust fans blower tables in BLOWER DATA section.
- 2- The RPM can be adjusted at the motor pulley. Loosen Allen screw and turn adjustable pulley clockwise to increase CFM. Turn counterclockwise to decrease CFM. Secure Allen screw. See figure 10.

BLOWER ASSEMBLY

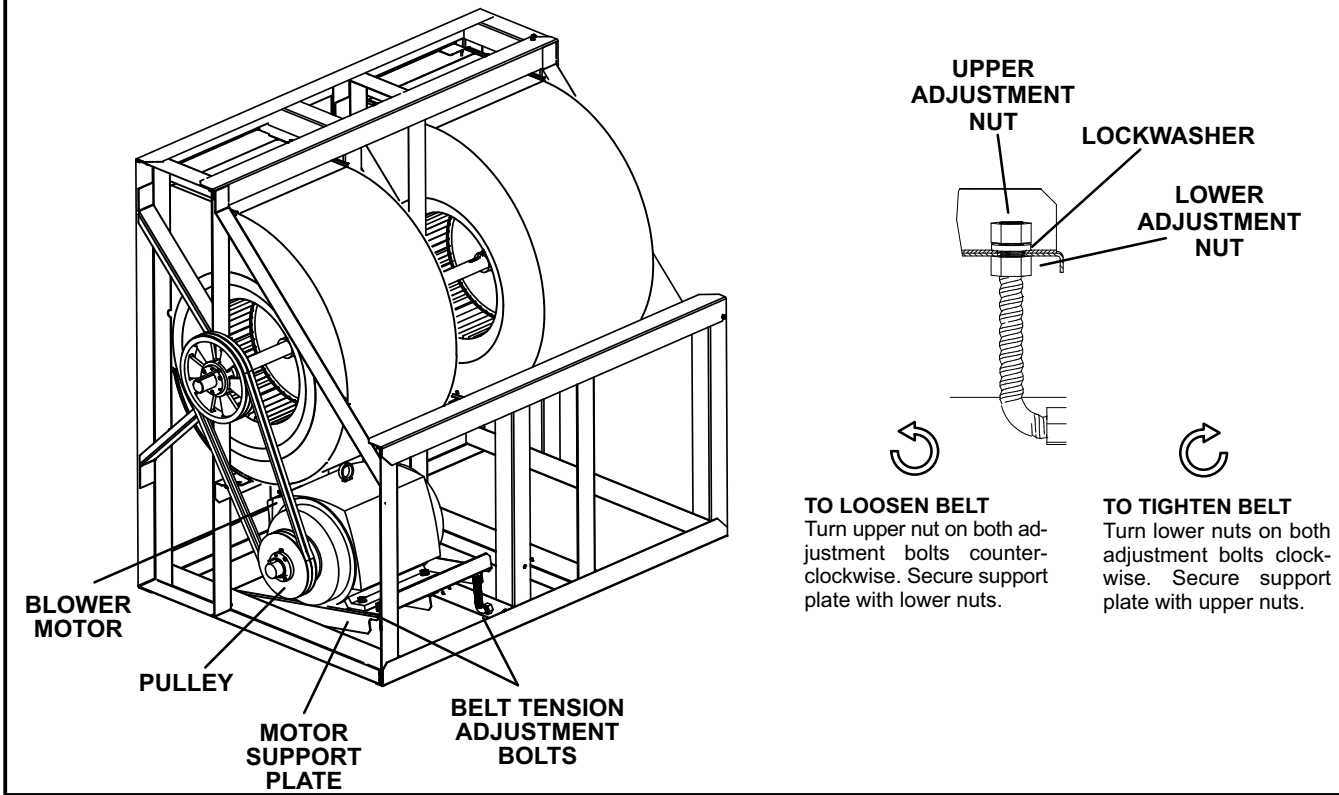

FIGURE 10

Blower Belt Adjustment

Maximum life and wear can be obtained from belts only if proper pulley alignment and belt tension are maintained. Tighten belt as shown in figure 10. Tension new belts after a 24-48 hour period of operation. This will allow belt to stretch and seat to grooves. Make sure blower and motor pulley are aligned as shown in figure 11. Also make sure motor support plate is level. See figure 12.

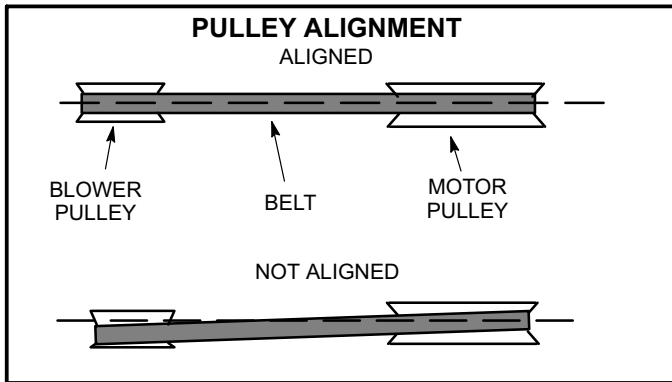

FIGURE 11

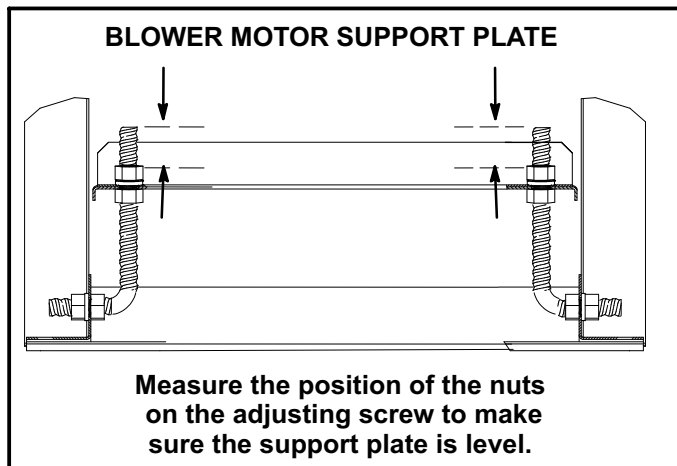

FIGURE 12

Check Belt Tension

Overtensioning belts shortens belt and bearing life. Check belt tension as follows:

- 1- Measure span length X. See figure 13.
- 2- Apply perpendicular force to center of span (X) with enough pressure to deflect belt 1/64" for every inch of span length or 0.4mm per 25.4mm of span length.

Example: Deflection distance of a 40" span would be 40/64" or 5/8".

Example: Deflection distance of a 1016mm span would be 16mm.

- 3- Measure belt deflection force. Used belt values apply when tightening the belt after 24-48 hours.

For a used belt, the deflection force should be:

5 lbs. for 5 & 7.5 HP applications

8 lbs. for 10 & 15 HP applications

7 lbs. for 20, 25, & 30 HP applications

For a new belt, the deflection force should be:

8 lbs. for 5 & 7.5 HP applications

12 lbs. for 10 & 15 HP applications

11 lbs. for 20, 25, & 30 HP applications

A force below these values indicates an undertensioned belt. A force above these values indicates an overtensioned belt.

Field-Furnished Blower Drives

For field-furnished blower drives, use manufacturer's drive number tables (see table of contents).

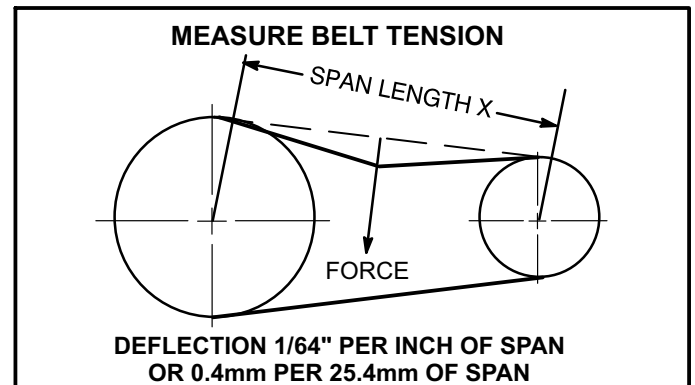

FIGURE 13

LGH HEATING PARTS ARRANGEMENT (high heat 11 burner, tube & standard heat 7 burner, tube)

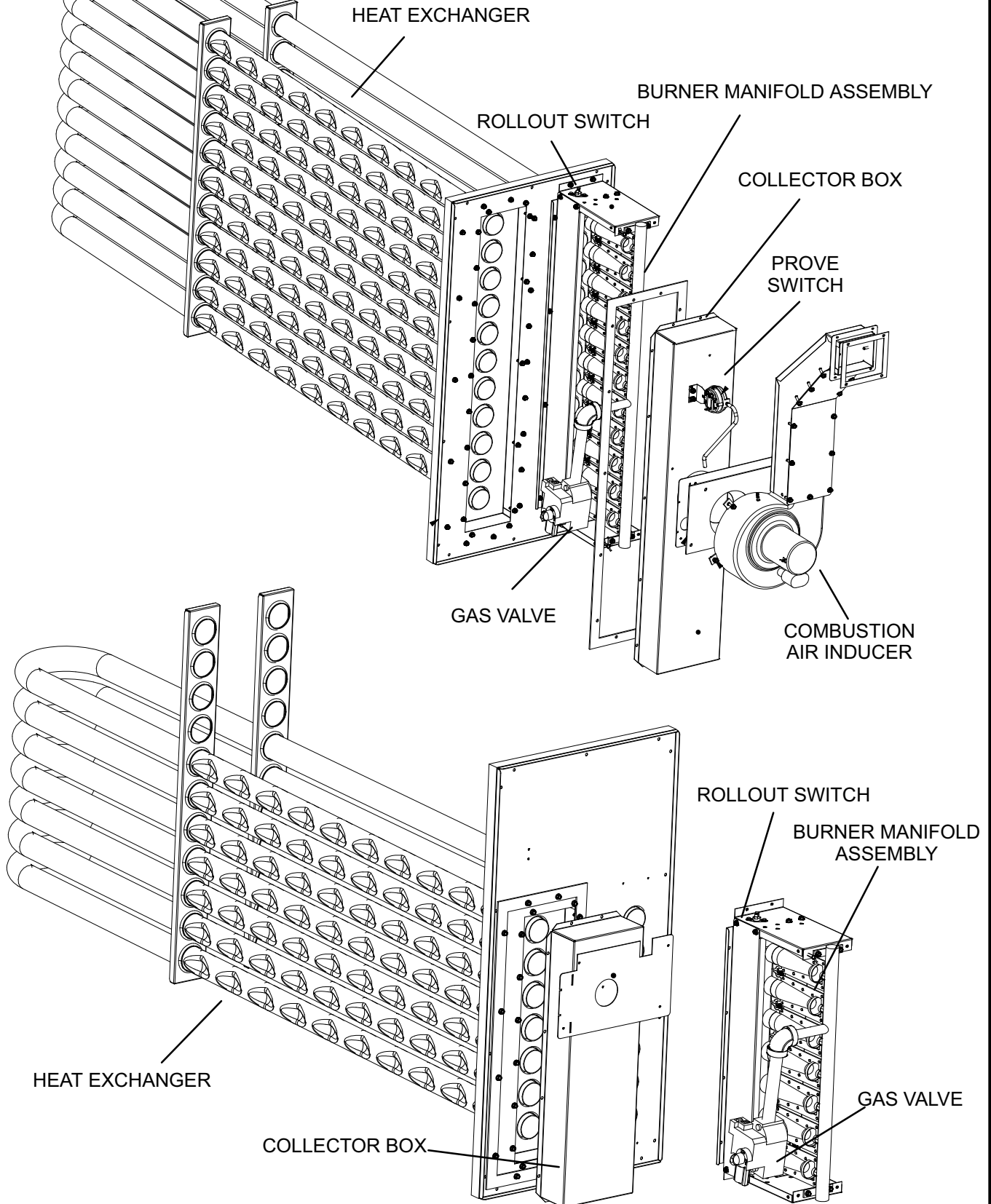

FIGURE 14

D-GAS HEAT COMPONENTS

All units are available in 500,000 BTUH (146.5 kW) (standard gas heat - 7 burner and tube heat-exchanger) or 800,000 BTUH (234.4 kW) (high gas heat - 11 burner and tube heat exchanger) sizes. All units are equipped with two gas heat sections (figure 15). In downflow position each section is protected by a high temperature control limit, S10 and S99. In horizontal position only, one primary limit is used (S10) and it is located in the blower compartment. For both applications a secondary limit (S21) is located in the blower compartment. See figure 19. Flexible pipe is used to connect the gas supply from one heat section to the other. Cast iron pipe will feed the supply gas to each gas valve.

NOTE - Care should be taken to insure flexible pipe does not touch any other part of the unit. Breaks or tears in the flexible pipe will result in a gas leak.

Heat Section Electrical Components

The heat section (see figure 15) houses the burner controls A3 and A12, combustion air inducers transformers T3 and T13 (480V & 575V only), combustion air inducer relays K13 and K19, gas relays K72 and K73 and limit relay K123.

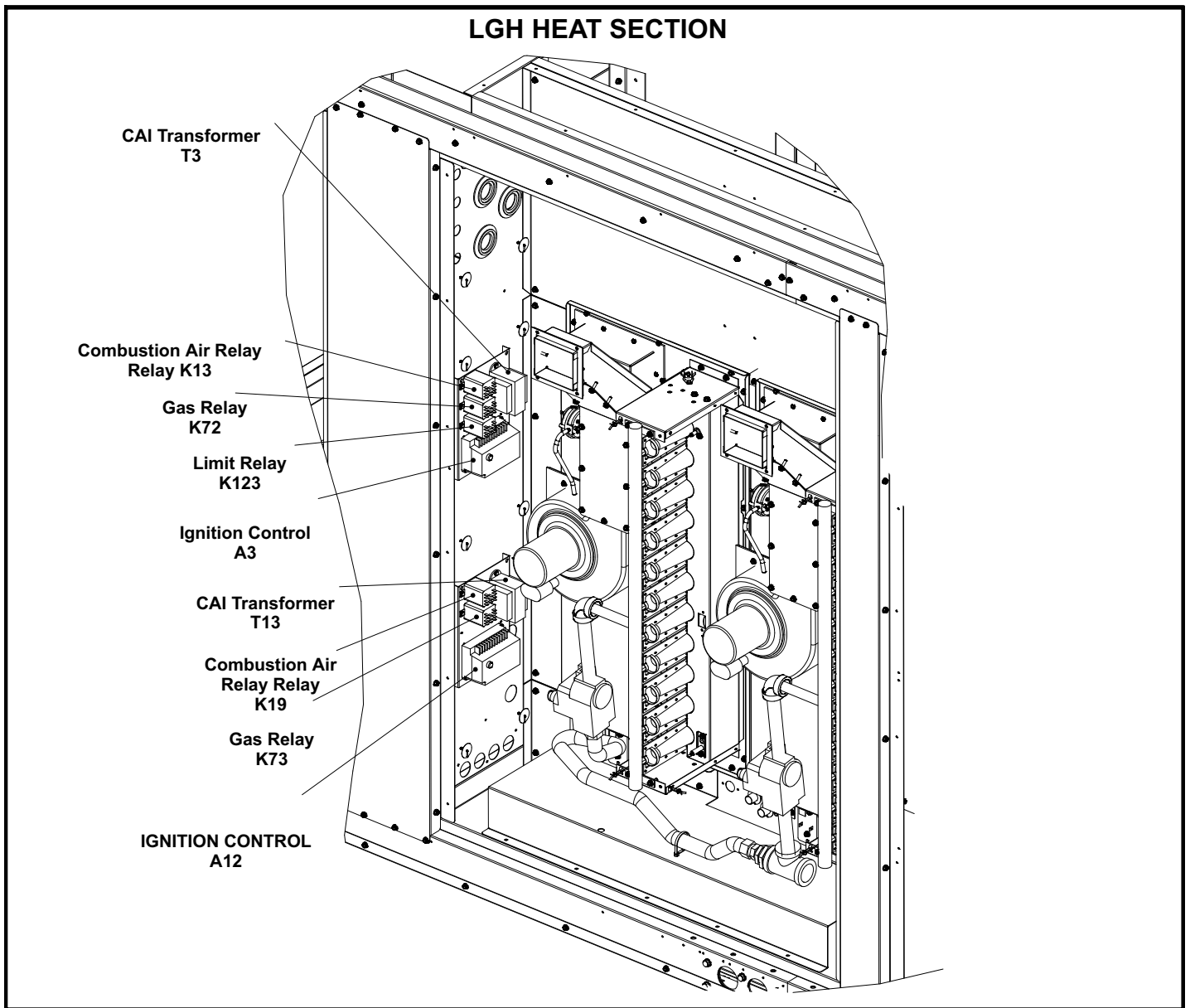

FIGURE 15

! WARNING

SHOCK HAZARD. SPARK RELATED COMPONENTS CONTAIN HIGH VOLTAGE WHICH CAN CAUSE PERSONAL INJURY OR DEATH. DISCONNECT POWER BEFORE SERVICING. CONTROL IS NOT FIELD REPAIRABLE. UNSAFE OPERATION WILL RESULT. IF THE CONTROL IS INOPERABLE, SIMPLY REPLACE THE ENTIRE CONTROL.

1-Burner Ignition Control A3 (heat section 1) & A12 (heat section 2)

The ignition controls are located in the control box. Two different manufacturers' (Utec and Fenwal) controls are used in the LGH units. Both ignition controls operate the same.

The ignition control provides three main functions: gas valve control, ignition and flame sensing. The unit will usually ignite on the first attempt; however, the ignition attempt sequence provides three trials for ignition before locking out. The lockout time for the Utec is 5 minutes. The lockout time for the Fenwal control is 5 minutes. After lockout, the ignition control automatically resets and provides three more attempts at ignition. Manual reset after lockout requires breaking and remaking power to the ignition control. Both controls have LEDs for troubleshooting. See table 1.

TABLE 1

UTEK	
LED Flashes	Indicates
Steady Off	No power or control hardware fault.
Steady On	Power applied. Control OK.
3 Flashes	Ignition lockout from too many trials.
4 Flashes	Ignition lockout from too many flame losses within single call for heat.
5 Flashes	Control hardware fault detected.
Kidde Fenwal	
LED Flashes	Indicates
Steady On	Internal control failure.
2 Flashes	Flame with no call for heat.
3 Flashes	Ignition lockout.

Flame rectification sensing is used on all LGH units. Loss of flame during a heating cycle is indicated by an absence of flame signal (0 microamps). If this happens, the control will immediately restart the ignition sequence and then lock out if ignition is not gained after the third trial. See table 12 for microamp signal values .

The control shuts off gas flow immediately in the event of a power failure. Upon restoration of gas and power, the control will restart the ignition sequence and continue until flame is established or system locks out.

On a heating demand, the ignition control is energized by the A55 Unit Controller. The ignition control then allows 30 to 40 seconds for the combustion air blower to vent exhaust gases from the burners. When the combustion air blower is purging the exhaust gases, the combustion air prove switch is closing proving that the combustion air blower is operating before allowing the ignition control to energize. When the combustion air prove switch is closed and the delay is over, the ignition control activates gas valve, the spark electrode and the flame sensing electrode. Sparking stops immediately after flame is sensed. The combustion air blower continues to operate throughout the heating demand. If the flame fails or if the burners do not ignite, the ignition control will attempt to ignite the burners up to two more times. If ignition cannot be obtained after the third attempt, the control will lock out. The ignition control is not adjustable.

The Utec control is illustrated in figure 16 and Fenwal control in figure 17. The spade connections are used to connect the control to unit. Each of the spade terminals are identified by function. The spark electrode wire connects to the spark-plug-type connector on top of the control.

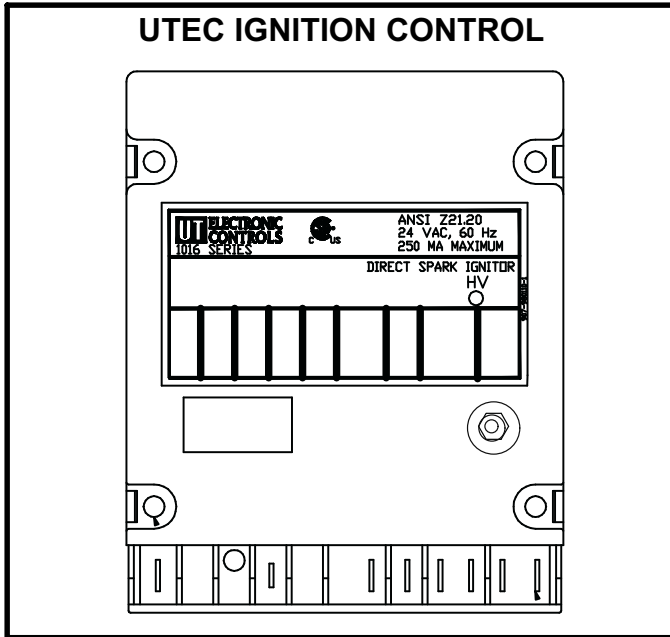

FIGURE 16

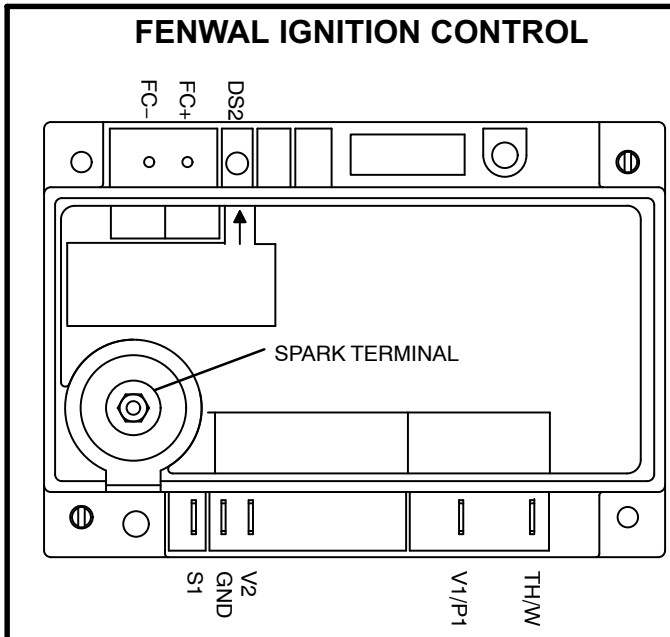

FIGURE 17

2-Combustion Air Inducer Relay K13

Combustion air inducer relay K13, used in all LGH units, is a DPDT relay with a 24VAC coil. K13 is energized by the A55 Unit Controller after a standard heating demand from the thermostat. K13 remains energized throughout the heating demand. When energized, K13 N.O. contacts close to energize the combustion air inducer and begin a heating sequence. Prove switch S18 closes as combustion air static pressure falls to “prove” combustion air inducer operation. When S18 closes, the ignition control and gas valve is energized to begin a heating sequence.

3-Combustion Air Inducer Relay K19

Combustion air inducer relay K19, used in all LGH units, is a DPDT relay with a 24 VAC coil. K19 is energized by the A178 Unit Controller after a standard heat demand from the thermostat. K19 remains energized throughout the demand. When energized, K19 N.O. contacts close to energize the second heat section combustion air inducer and begin second section heating sequence. Prove switch S45 closes as combustion air static pressure falls to “prove” combustion air inducer operation. When S45 closes, the ignition control and gas valve is energized to begin the heating sequence.

4-Limit Relay K123

Relay K123 is a 3PDT relay wired in series with primary limits S10, S99 and secondary S21. K123 remains energized as long as S10, S99 and S21 contacts remain closed. If any of the three limits open, K123 is de-energized shutting down heat sections.

5-Gas Valve Relays K72 & K73

K72 and K73 are SPDT relays wired in series with combustion air inducer relays K13 and K19 respectively and with gas valves GV1 and GV3. On a call for second stage heat (W2), the relays normally open terminals “5” and “7” close, energizing combustion air inducers B6 and B15 on second stage heat (high speed).

6-C.A.I. Transformers T3 & T13 (460 & 575 Volts Only)

LGH 460 (G) and 575 (J) voltage units use two autotransformers to provide 230VAC. Transformers are mounted in the heat section. The transformers have an output rating of 0.5A. T3 supplies 230VAC power to combustion air inducer B6, while T13 supplies power to combustion air inducer B15.

7-Heat Exchanger (Figure 14)

The LGH units use aluminized steel inshot burners with matching tubular aluminized steel (stainless steel is an option) heat exchangers and two-stage redundant gas valves. LGH uses two eleven tube/burners for high heat and two seven tube/burners for standard heat. Each burner uses a burner venturi to mix gas and air for proper combustion. Combustion takes place at each tube entrance. As hot combustion gases are drawn through each tube by the combustion air blower, exhaust gases are drawn out and fresh air/gas mixture is drawn in. Heat is transferred to the air stream from all surfaces of the heat exchanger tubes. The supply air blowers, controlled by the A55 Unit Controller, force air across all surfaces of the tubes to extract the heat of combustion. The shape of the tubes ensures maximum heat exchange.

The gas valves accomplish staging by allowing more or less gas to the burners as called for by heating demand.

8-Burner Assembly (Figure 14)

The burners are controlled by the spark electrode, flame sensing electrode, gas valve and combustion air blower. The spark electrode, flame sensing electrode and gas valve are directly controlled by ignition control. The ignition control and combustion air blower are controlled by the Unit Controller.

Burners

All units use inshot burners (see figure 18). Burners are factory set and do not require adjustment. A peep hole with cover is furnished in the heating access panel for flame viewing. Always operate the unit with the access panel in place. Burners can be removed individually for service. Burner maintenance and service is detailed in the SERVICE CHECKS sections of this manual.

Orifice

Each burner uses an orifice which is precisely matched to the burner input. The orifice is threaded into the burner manifold. The burner is supported by the orifice and will easily slide off for service.

NOTE-Do not use thread sealing compound on the orifices. Using thread sealing compound may plug the orifices.

Each orifice and burner are sized specifically to the unit.

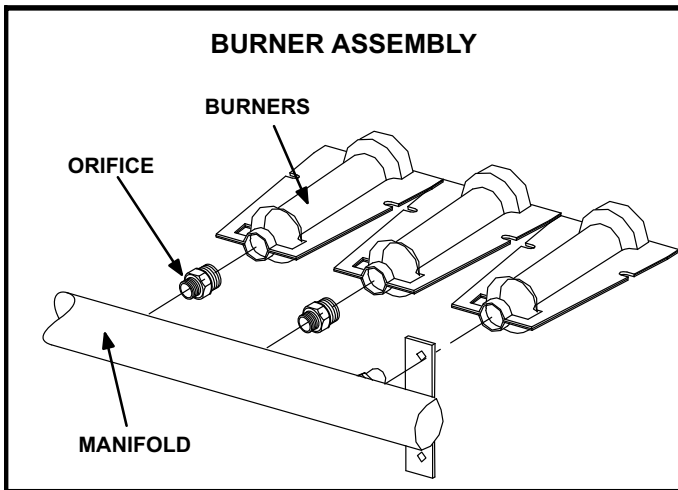

FIGURE 18

9-Primary High Temperature Limits S10 & S99

S10 and S99 are SPST N.C. auto-reset limit switches. S10 and S99 are the primary high temperature limits for the heat sections. See figure 19 for location of S10 and S99. In horizontal positions S10 is used only and located in the blower compartment.

Both limit switches are wired in series with limit relay K123 which is wired to A55. Once K123 contacts open both heat sections shuts down and the indoor blower is energized.

Limit set points are factory set and cannot be adjusted. See table 2.

TABLE 2

Btu Capacity	S10	S99	S21
Standard 500,000	open $140^{\circ} \pm 5^{\circ}$ close $110 \pm 8^{\circ}$		open $185^{\circ} \pm 5^{\circ}$ close $145^{\circ} \pm 7^{\circ}$
High 800,000	open $150^{\circ} \pm 5^{\circ}$ close $120 \pm 8^{\circ}$		

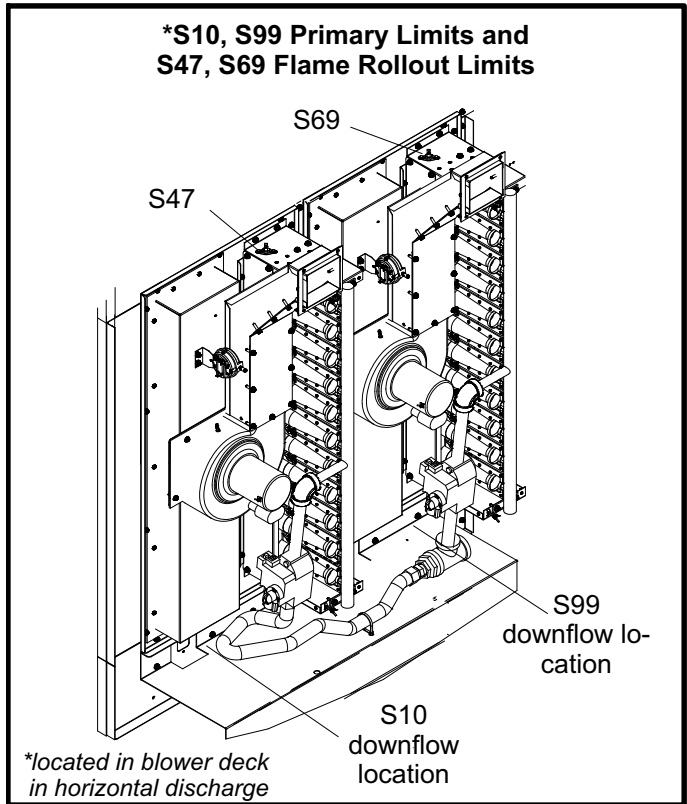

FIGURE 19

10-Secondary High Temperature Limit S21

S21 is the secondary high temperature limit used for both heat sections. The secondary limit is located in the blower compartment.

Secondary limit S21 is also wired to limit relay K123 and functions in the same manner as the primary limits, but is factory set to actuate at a different temperature. All limits used are SPST N.C. auto-reset limits.

Limit set points are factory set and cannot be adjusted. If limit must be replaced same type and set point must be used.

11-Flame Rollout Limits S47 and S69

Flame rollout limits S47 and S69 are SPST N.C. high temperature limits located on top of the burner box. S47 and S69 are wired to the Unit Controller. When S47 or S69 sense flame rollout (indicating a blockage in the combustion air passages), the corresponding flame rollout limit trips and the ignition control immediately closes the gas valve.

Limit S47 and S69 are factory preset to open at $250^{\circ}\text{F} \pm 12^{\circ}\text{F}$ ($121.1^{\circ}\text{C} \pm 6.7^{\circ}\text{C}$) on a temperature rise. All flame rollout limits are manual reset.

12-Combustion Air Prove Switches S18 & S45

The combustion air prove switch S18 and S45 are SPST N.O. pressure switches located in the heat section (see figure 14). Both switches are identical and used to monitor combustion air blower operation. Switch S18 and S45 are wired to the Unit Controller. The switch actuates on a negative pressure fall. This pressure fall and switch actuation allows power to the ignition control (proves, by closing, that the combustion air inducer is operating before allowing the ignition control to energize). The combustion air prove switch is factory set and not adjustable. The switch will automatically open on a pressure rise (less negative). Table 3 shows prove switch settings for unit production dates before and after February 2009.

TABLE 3
S18 & S45 Prove Switch Settings

Unit Production Date	Close " w.c. (Pa)	Open " w.c. (Pa)
Feb. 2009 & Later	0.25 ± 5 (62.3±12.4)	0.10±5 (24.8±12.4)
Prior to Feb. 2009	0.46±5 (114±12.4)	0.31±5 (77.2±12.4)

13-Combustion Air Inducers B6 and B15

Combustion air inducers B6 and B15 are identical two speed inducers which provide fresh air to the corresponding burners while clearing the combustion chamber of exhaust gases.

On a heating demand, the ignition control is energized by the A55 Unit Controller. The ignition control then allows 30 to 40 seconds for the combustion air inducer to vent exhaust gases from the burners. When the combustion air inducer is purging the exhaust gases, the combustion air prove switch is closing proving that the combustion air inducer is operating before allowing the ignition control to energize. When the combustion air prove switch is closed and the delay is over, the ignition control activates the first stage operator of the gas valve (low fire), the spark and the flame sensing electrode. Sparking stops immediately after flame is sensed. The inducers switch to second stage speed on a W2 call for second stage heat.

All motors operate at 3200 RPM and are equipped with auto-reset overload protection. Inducers are supplied by various manufacturers. Ratings may vary by manufacturer. Specific inducer electrical ratings can be found on the unit rating plate.

All combustion air inducer motors are sealed and cannot be oiled. The inducer cannot be adjusted but can be disassembled for cleaning.

14-Combustion Air Motor Capacitors C3 & C11

The combustion air inducer motors in all LGH units require run capacitors. Capacitor C3 is connected to combustion air inducer B6 and C11 is connected to combustion air inducer B15. Ratings for capacitor will be on combustion air inducer motor nameplate or see side of capacitor.

15-Gas Valves GV1 and GV3

GV1 and GV3 are identical two stage redundant gas valves. Units are equipped with valves manufactured by White-Rodgers. The valve is quick opening on first stage heat, but slow opening on second stage heat (on to second stage in 40 seconds and off to first stage in 30 seconds). *The valve is adjustable for second stage heat only.* On a call for first stage heat, the valve is energized by the ignition control simultaneously with the spark electrode. On a call for high heat, the second stage operator is energized directly from A178 (GV1 and GV3). A manual shut-off knob is provided on the valve for shut-off. Manual shut-off knob immediately closes both stages without delay. Figure 20 shows the gas valve components. Table 4 shows factory gas valve regulation for LGH series units.

16-Spark Electrodes

An electrode assembly is used for ignition spark. Two identical electrodes are used (one for each gas heat section). The electrode tip protrudes into the flame envelope of the adjacent burner. The electrode assembly is fastened to burner supports and can be removed for service without removing any part of the burners. Simply remove the two screws securing the electrode assembly and slide it out of unit.

During ignition, spark travels through the spark electrode (figure 21) and ignites the bottom burner. Flame travels from burner to burner until all are lit.

The spark electrode is connected to the ignition control by a 8 mm silicone-insulated stranded high voltage wire. The wire uses 1/4" (6.35 mm) female quick connect on the electrode end and female spark plug-type terminal on the ignition control end.

Spark gap may be checked with appropriately sized twist drills or feeler gauges. Disconnect power to the unit and remove electrode assembly. The gap should be between 0.125" ± 0.015" (3.2 mm ± .4 mm). See figure 21.

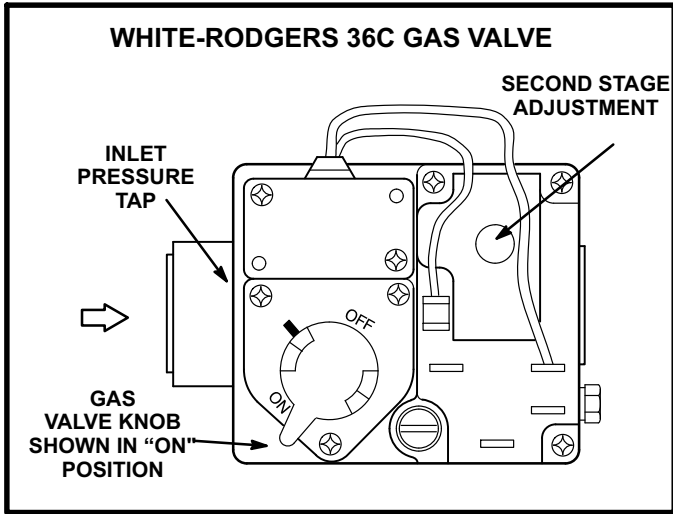

FIGURE 20

TABLE 4

GAS VALVE REGULATION FOR LGH UNITS			
Operating Pressure (outlet) Factory Setting			
Natural		L.P.	
Low	High	Low	High
1.6±0.2"W.C. 398±50Pa	3.7±0.3"W.C. 920±75Pa	5.5±0.3"W.C. 1368±75Pa	10.5±0.5"W.C. 2611±125Pa

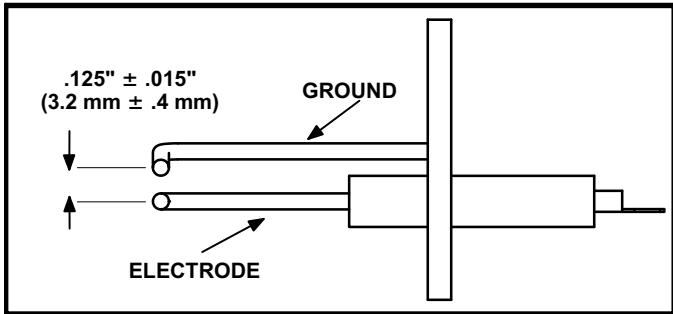

FIGURE 21

NOTE- IN ORDER TO MAXIMIZE SPARK ENERGY TO ELECTRODE, HIGH VOLTAGE WIRE SHOULD TOUCH UNIT CABINET AS LITTLE AS POSSIBLE.

17-Flame Sensors

A flame sensor is located on the top end of each burner support. The sensor is mounted through a hole in the burner support and the tip protrudes into the flame envelope of the right most burner. The sensor assembly is fastened to burner supports and can be removed for service without removing any part of the burners.

When flame is sensed by the flame sensor (indicated by microamp signal through the flame) sparking stops immediately. During operation, flame is sensed by current passed along the ground electrode (located on the spark electrode), through the flame and into the sensing electrode. The ignition control allows the gas valve to stay open as long as a flame signal (current passed through the flame) is sensed.

E-ELECTRIC HEAT COMPONENTS

See ELECTRIC HEAT DATA tables (table of contents) for possible LCH to EHA match-ups and electrical ratings.

EHA parts arrangement is shown in figure 22. All electric heat sections consist of electric heating elements exposed directly to the air stream. Multiple-stage elements are sequenced on and off in response to thermostat demand.

1-Electric Heat Relay K9

LCH units equipped with 75 to 180kW electric heat use an electric heat relay K9. K9 is a N.O. SPST pilot relay intended to electrically isolate the unit's 24V circuit from the electric heat 24V circuit. K9 is energized by the A55 Unit Controller. K9-1 closes, enabling the unit controller to energize the electric heat contactors.

2-Contactors K15, K16 and K17 all voltages

Contactors K15, K16 and K17 are all three-pole double-break contactors located on the electric heat vestibule. All contactors are equipped with a 24VAC coil. The coils in the K15, K16 and K17 contactors are energized by the Unit Controller. Contactors K15 and K16 energize the first stage heating elements, while K17 energizes the second stage heating elements.

3-Contactors K18, K75 and K76

These contactors are found on G and J voltage, 105 through 180kW EHA units. Contactors K18, K75 and K76 are identical to contactors K15. K16 and K17. The coils on these contactors are energized by the Unit Controller and relay K9. K18, K75 and K76 energize the second stage heating elements.

4-Primary Limit S15

S15 is an auto-reset thermostat wired in series with contactor K15 and relay K9. When S15 opens, indicating a problem in the system, K15 and K9 are de-energized and first stage and all subsequent stages of heat are de-energized. S15 is factory set and cannot be adjusted.

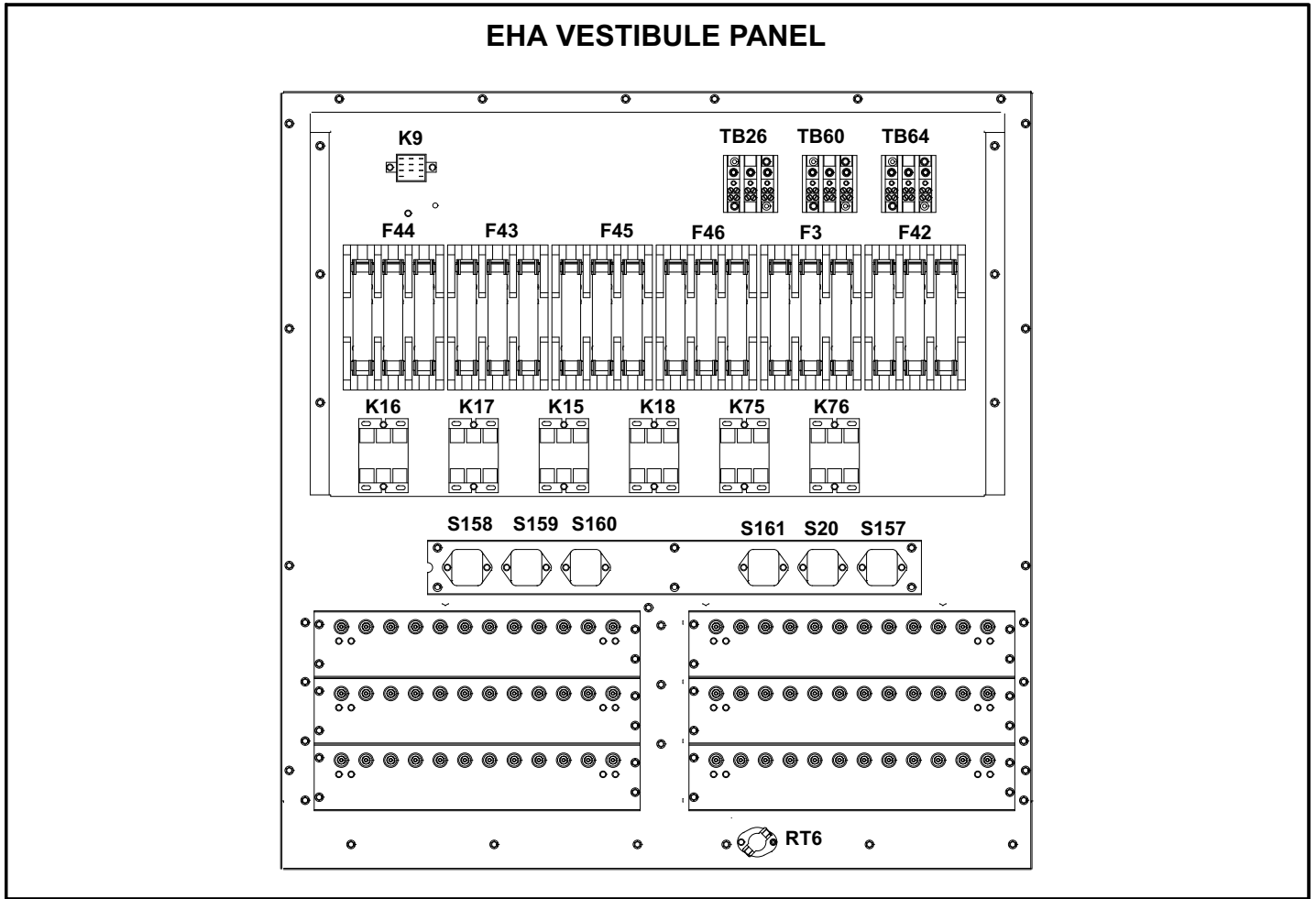

FIGURE 22

5-Secondary Limits S20, S157, S158, S159, S160 and S161

S20, S157, S158, S159, S160 and S161 are manual reset limit switches that provide back up high temperature protection. Each limit is wired in series with a contactor and heating element. When one or more limit opens the heating element is de-energized which in turn de-energizes the heating element. See EHA diagram for secondary limit / contactor match-up.

6-Heating Elements HE1 through HE12

Heating elements are composed of helix wound bare nichrome wire exposed directly to the air stream. Three elements are connected in a three-phase arrangement. The elements in 208/230V units are connected in a "Delta" arrangement. Elements in 460 and 575V units are connected in "Wye" arrangement. See EHA wiring diagrams in back of this manual. Each stage is energized independently by the corresponding contactors located on the electric heat vestibule panel. Once energized, heat transfer is instantaneous. High temperature protection is provided by primary and redundant high temperature limits and overcurrent protection is provided by fuses.

7-Fuses F3, F42, F43, F44, F45, F46

F3, F42, F43, F44, F45 and F46 are 250V 60 amp (Y voltage) and 660V 60 amp (G and J voltage) fuses that provide overcurrent protection to HE1 through HE12. Each fuse is connected in series with a heating element. See EHA diagram for specific fuse / heating element match up.

8-Terminal Block TB3

Terminal block TB3 is used to distribute power to electric heat components.

9-Terminal Blocks TB26, TB64 and TB60

These terminal blocks are used to distribute power from L1, L2 and L3 to its respective heating element. See EHA diagrams.

II-PLACEMENT AND INSTALLATION

Make sure the unit is installed in accordance with the installation instructions and all applicable codes. See accessories section for conditions requiring use of the optional roof mounting frame (RMFE-14).

III-START UP - OPERATION

IMPORTANT-The crankcase heater must be energized for 24 hours before attempting to start compressor. Set thermostat so there is no demand to prevent compressors from cycling.

A-Preliminary Checks

- 1- Make sure that unit is installed in accordance with the installation instructions and applicable codes.
- 2- Inspect all electrical wiring, both field- and factory-installed, for loose connections. Tighten as required.
- 3- Check to ensure that refrigerant lines do not rub against the cabinet or against other refrigerant lines.
- 4- Check voltage at disconnect switch. Voltage must be within range listed on nameplate. If not, consult power company and have voltage condition corrected before starting unit.
- 5- Make sure filters are in place before start-up.

B-Cooling Start-Up

- 1- Initiate first and second stage cooling demands according to instructions provided with thermostat.
- 2- *2 Heat / 2 Cool Thermostat* -
First-stage thermostat demand will energize compressors 1 and 2. Second-stage thermostat demand will energize compressors 3 and 4. On units with an

economizer, when outdoor air is acceptable, a first-stage demand will energize the economizer; a second-stage demand will energize compressors 1 and 2. Refer to the Unit Controller manual provided with each unit for other staging options.

- 3- Each refrigerant circuit is separately charged with R-410A refrigerant. See unit rating plate for correct amount of charge. See figure 23 for refrigerant routing on VAV units and MSAV units without re-heat. See figure 42 for refrigerant routing on units equipped with a reheat coil (Humiditrol).
- 4- Refer to Cooling Operation and Adjustment section for proper method to check refrigerant charge.

Manifold gauge sets used with systems charged with R-410A refrigerant must be capable of handling the higher system operating pressures. The gauges should be rated for use with pressures of 0-800 on the high side and a low side of 30" vacuum to 250 psi with dampened speed to 500 psi. Gauge hoses must be rated for use at up to 800 psi of pressure with a 4000 psi burst rating.

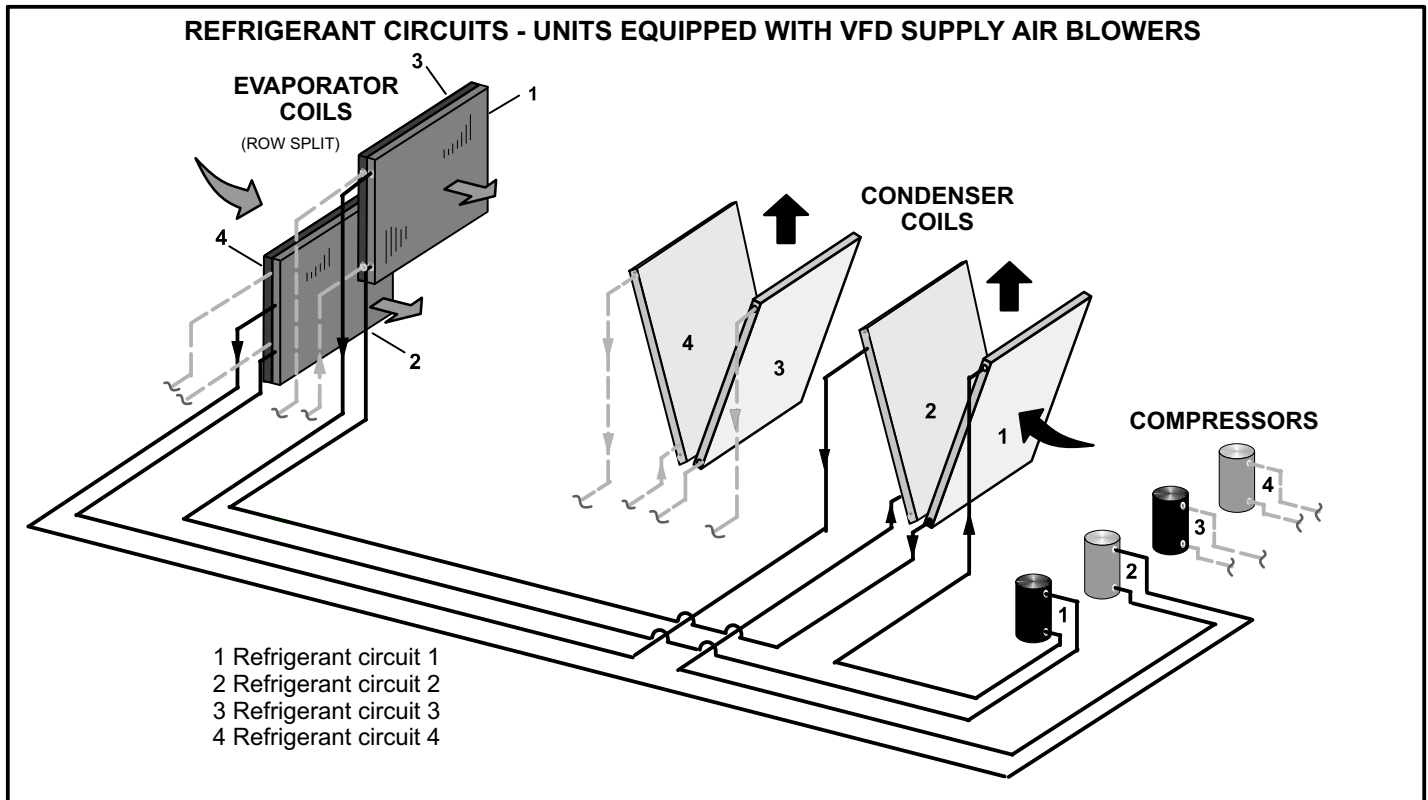

FIGURE 23

C-Refrigerant Charge and Check

WARNING-Do not exceed nameplate charge under any condition.

This unit is factory charged and should require no further adjustment. If the system requires refrigerant, reclaim the charge, evacuate the system and add required nameplate charge.

NOTE - System charging is not recommended below 60°F (15°C). In temperatures below 60°F (15°C), the charge **must** be weighed into the system.

If weighing facilities are not available, or to check the charge, use the following procedure:

IMPORTANT - Charge unit in cooling mode. Make sure re-heat (Humiditrol) is not energized.

- 1- Attach gauge manifolds and operate unit in cooling mode at full CFM with economizer disabled until system stabilizes (approximately five minutes). Make sure all outdoor air dampers are closed.
- 2- Check each system separately with all stages operating.
- 3- Use a thermometer to accurately measure the outdoor ambient temperature.
- 4- Apply the outdoor temperature to tables 5 through 10 to determine normal operating pressures. Pressures are listed for sea level applications at 80°F dry bulb and 67°F wet bulb return air.
- 5- Compare the normal operating pressures to the pressures obtained from the gauges. Minor variations in these pressures may be expected due to differences in installations. Significant differences could mean that the system is not properly charged or that a problem exists with some component in the system. **Correct any system problems before proceeding.**
- 6- If discharge pressure is high, remove refrigerant from the system. If discharge pressure is low, add refrigerant to the system.
 - Add or remove charge in increments.
 - Allow the system to stabilize each time refrigerant is added or removed.
- 7- Use the following approach method along with the normal operating pressures to confirm readings.

TABLE 5
LGH/LCH420S - R410A - VFD

Outdoor Coil Entering Air Temp	Circuit 1		Circuit 2		Circuit 3		Circuit 4	
	Dis. +10 psig	Suc. +5 psig	Dis. +10 psig	Suc. +5 psig	Dis. +10 psig	Suc. +5 psig	Dis. +10 psig	Suc. +5 psig
65°F*	280	112	310	115	310	137	312	141
75°F	330	115	360	118	350	140	350	143
85°F	380	117	410	121	400	142	380	141
95°F	420	121	470	125	450	144	435	143
105°F	495	124	530	128	510	146	490	147
115°F	535	128	590	131	570	148	550	150

TABLE 6
LGH/LCH420H - R410 - VFD

Outdoor Coil Entering Air Temp	Circuit 1		Circuit 2		Circuit 3		Circuit 4	
	Dis. +10 psig	Suc. +5 psig	Dis. +10 psig	Suc. +5 psig	Dis. +10 psig	Suc. +5 psig	Dis. +10 psig	Suc. +5 psig
65°F*	250	121	280	124	260	140	270	140
75°F	300	124	320	126	305	142	306	142
85°F	330	126	370	127	340	143	350	144
95°F	390	130	420	131	400	146	390	147
105°F	420	131	470	132	450	147	460	148
115°F	470	134	540	134	510	149	520	150

TABLE 7
LGH/LCH480S - R410A - VFD

Outdoor Coil Entering Air Temp	Circuit 1		Circuit 2		Circuit 3		Circuit 4	
	Dis. +10 psig	Suc. +5 psig	Dis. +10 psig	Suc. +5 psig	Dis. +10 psig	Suc. +5 psig	Dis. +10 psig	Suc. +5 psig
65°F*	282	114	317	116	315	138	316	139
75°F	336	116	361	118	353	139	351	143
85°F	389	119	414	121	403	142	396	145
95°F	429	122	470	124	451	144	441	144
105°F	502	126	529	128	511	147	498	147
115°F	547	130	595	131	576	149	558	150

TABLE 8
LGH/LCH480H - R410A - VFD

Outdoor Coil Entering Air Temp	Circuit 1		Circuit 2		Circuit 3		Circuit 4	
	Dis. +10 psig	Suc. +5 psig	Dis. +10 psig	Suc. +5 psig	Dis. +10 psig	Suc. +5 psig	Dis. +10 psig	Suc. +5 psig
65°F*	250	121	283	124	267	140	273	140
75°F	301	124	324	126	305	142	306	142
85°F	331	136	371	127	349	143	355	144
95°F	390	130	420	131	398	146	389	147
105°F	428	131	477	132	456	147	459	148
115°F	479	134	537	134	516	149	522	150

TABLE 9
LGH/LCH540S - R410A - VFD

Outdoor Coil Entering Air Temp	Circuit 1		Circuit 2		Circuit 3		Circuit 4	
	Dis. +10 psig	Suc. +5 psig	Dis. +10 psig	Suc. +5 psig	Dis. +10 psig	Suc. +5 psig	Dis. +10 psig	Suc. +5 psig
65°F*	285	119	324	124	320	138	310	139
75°F	329	121	368	125	355	139	350	140
85°F	391	125	418	128	400	142	400	142
95°F	454	127	476	129	460	144	450	144
105°F	497	130	525	133	515	145	500	147
115°F	554	133	580	136	570	147	555	149

TABLE 10
LGH/LCH600S - R410A - VFD

Outdoor Coil En- tering Air Temp	Circuit 1		Circuit 2		Circuit 3		Circuit 4	
	Dis ±10 psig	Suc ±5 psig	Dis ±10 psig	Suc ±5 psig	Dis ±10 psig	Suc ±5 psig	Dis ±10 psig	Suc ±5 psig
65°F*	251	109	300	111	297	135	295	135
75°F	304	111	342	113	338	136	335	137
85°F	343	114	388	115	382	139	384	140
95°F	398	117	433	117	433	141	424	142
105°F	445	119	489	119	485	142	477	144
115°F	490	122	545	121	537	145	521	146

D-Charge Verification - Approach Method - AHRI TESTING

- Using the same thermometer, compare liquid temperature to outdoor ambient temperature.
Approach Temperature = Liquid temperature (at condenser outlet) minus ambient temperature.
- Approach temperature should match values in table 11. An approach temperature greater than value shown indicates an undercharge. An approach temperature less than value shown indicates an overcharge.
- The approach method is not valid for grossly over or undercharged systems. Use tables 5 through 10 as a guide for typical operating pressures.

TABLE 11
APPROACH TEMPERATURES

420S, 540S	8°F ± 1 (4.4 ± 0.5)
420H, 480H,	6°F ± 1 (3.3 ± 0.5)
480S	9°F ± 1 (5.0 ± 0.5)
600S	7°F ± 1 (3.9 ± 0.5)

E-Heating Start Up

FOR YOUR SAFETY READ BEFORE LIGHTING

BEFORE LIGHTING smell all around the appliance area for gas. Be sure to smell next to the floor because some gas is heavier than air and will settle on the floor.

Use only your hand to push in or turn the gas control knob. Never use tools. If the knob will not push in or turn by hand, do not try to repair it, call a qualified service technician. Force or attempted repair may result in a fire or explosion.

⚠ WARNING



Electric shock hazard. Can cause injury or death. Before attempting to perform any service or maintenance, turn the electrical power to unit OFF at disconnect switch(es). Unit may have multiple power supplies.

⚠ WARNING



Danger of explosion. Can cause injury or product or property damage. If overheating occurs or if gas supply fails to shut off, shut off the manual gas valve to the appliance before shutting off electrical supply.

⚠ WARNING

SMOKE POTENTIAL

The heat exchanger in this unit could be a source of smoke on initial firing. Take precautions with respect to building occupants and property. Vent initial supply air outside when possible.

⚠ WARNING



Danger of explosion. Can cause injury or death. Do not attempt to light manually. Unit has a direct spark ignition system.

This unit is equipped with an automatic spark ignition system. There is no pilot. In case of a safety shutdown, move thermostat switch to **OFF** and return the thermostat switch to **HEAT** to reset ignition control.

Placing Unit In Operation

⚠ WARNING



Danger of explosion and fire. Can cause injury or product or property damage. You must follow these instructions exactly.

Gas Valve Operation for White Rodgers 36C Series Valve (Figure 24)

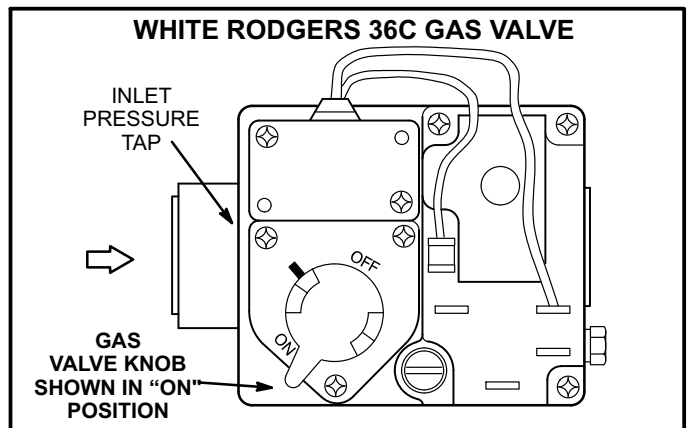





FIGURE 24

- Set thermostat to lowest setting.
- Turn off all electrical power to appliance.

- 3- This appliance is equipped with an ignition device which automatically lights the burner. Do **not** try to light the burner by hand.
- 4- Open or remove the heat section access panel.
- 5- Turn the knob on the gas valve clockwise  to **OFF**. Do not force.
- 6- Wait five minutes to clear out any gas. If you then smell gas, **STOP!** Immediately call your gas supplier from a neighbor's phone. Follow the gas supplier's instructions. If you do not smell gas, go to the next step.
- 7- Turn the knob on the gas valve counterclockwise  to **ON**. Do not force.
- 8- Close or replace the heat section access panel.
- 9- Turn on all electrical power to unit.
- 10- Set thermostat to desired setting.
- 11- The combustion air inducer will start. The burners will light within 40 seconds.
- 12- If the appliance does not light the first time (gas line not fully purged), it will attempt up to two more ignitions before locking out.
- 13- If lockout occurs, repeat steps 1 through 10.
- 14- If the appliance will not operate, follow the instructions "Turning Off Gas to Appliance" and call your service technician or gas supplier.

Turning Off Gas to Unit

- 1- If using an electromechanical thermostat, set to the lowest setting.
- 2- Before performing any service, turn off all electrical power to the unit.
- 3- Open or remove the heat section access panel.
- 4- Turn the knob on the gas valve clockwise  to **OFF**. Do not force.
- 5- Close or replace the heat section access panel.

F-Safety or Emergency Shutdown

Turn off power to unit. Close manual and main gas valves.

IV- SYSTEMS SERVICE CHECKS

A-LGH Heating System Service Checks

All LGH units are C.G.A. design certified without modification.

Before checking piping, check with gas company or authorities having jurisdiction for local code requirements. Refer to the LGH Installation, Operation and Maintenance instruction for more information.

1-Gas Piping

Gas supply piping must not allow more than 0.5"W.C. (124.3 Pa) drop in pressure between the gas meter and the unit. Supply gas pipe must not be smaller than the unit gas connection. Refer to installation instructions for details.

2-Testing Gas Piping

NOTE-In case emergency shutdown is required, turn off the main manual shut-off valve and disconnect the main power to the unit. These controls should be properly labeled by the installer.

When pressure testing gas lines, the gas valve must be disconnected and isolated. Gas valves can be damaged if subjected to more than 0.5 psig [14"W.C. (3481 Pa)]. See figure 25.

When checking piping connection for gas leaks, use the preferred means. Common kitchen detergents can cause harmful corrosion on various metals used in gas piping. The use of specialty Gas Leak Detector is strongly recommended. It is available through under part number 31B2001. See CORP 8411-L10, for further details.

Do not use matches, candles, flame or any other source of ignition to check for gas leaks.

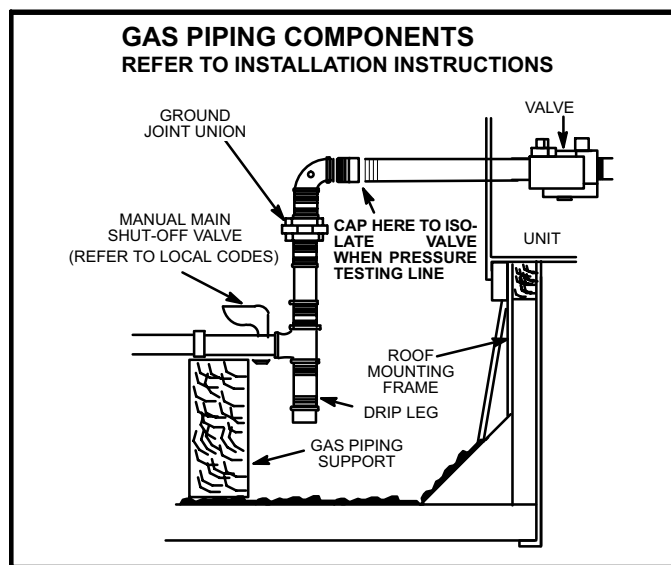

FIGURE 25

3-Testing Gas Supply Pressure

When testing gas supply pressure, connect test gauge to the inlet pressure tap on the gas valve (figure 24).

Test supply gas pressure with unit firing at maximum rate (both stages energized). Make sure the reading falls within the range of the following values. Low pressure may result in erratic operation or "underfire." High pressure can result in permanent damage to the gas valve or "overfire." For natural gas units, operating pressure at the unit gas connec-

tion must be between 4.7"W.C. and 10.5"W.C. (1168 Pa and 2610 Pa). For L.P. gas units, operating pressure at the unit gas connection must be between 10.8"W.C. and 13.0"W.C. (2685 Pa and 3232 Pa).

On multiple unit installations, each unit should be checked separately while operating at maximum rate, beginning with the one closest to the supply gas main and progressing to the one furthest from the main. Multiple units should also be tested with and without the other units operating. Supply pressure must fall within the range listed in the previous paragraph.

4-Check and Adjust Manifold Pressure

After line pressure has been checked and adjusted, check manifold pressure. Move test gauge to the outlet pressure tap located on unit gas valve GV1. See table 4 in GAS HEAT COMPONENT section for proper manifold pressure and figure 20 for location of pressure tap on the gas valve.

The manifold pressure is factory set and should not require adjustment. If manifold pressure is incorrect and no other source of improper manifold pressure can be found, the valve must be replaced. Refer to figure 20 for location of gas valve (manifold pressure) adjustment screw.

All gas valves are factory regulated. The gas valve should completely and immediately cycle off in the event of gas or power failure. The manual shut-off knob can be used to immediately shut off gas supply.

⚠ CAUTION

For safety, connect a shut-off valve between the manometer and the gas tap to permit shut off of gas pressure to the manometer.

Manifold Adjustment Procedure

- 1- Connect test gauge to the outlet pressure tap on the gas valve. Start the unit (call for second stage heat) and allow five minutes for the unit to reach steady state.
- 2- While waiting for the unit to stabilize, notice the flame. The flame should be stable without flashback and should not lift from the burner heads. Natural gas should burn basically blue with some clear streaks. L.P. gas should burn mostly blue with some clear yellow streaks.
- 3- After allowing the unit to stabilize for five minutes, record the manifold pressure and compare to the values given for gas supply pressure in table 4.

⚠ CAUTION

Disconnect heating demand as soon as an accurate reading has been obtained.

5-Proper Gas Flow

To check for proper gas flow to burners, determine Btuh input from unit rating plate or the gas heating capacity tables in the SPECIFICATIONS section of this manual. Divide this input rating by the Btuh per cubic foot of available gas. Result is the number of cubic feet per hour required. Determine the flow of gas through gas meter for two minutes and multiply by 30 to get hourly flow of gas to the burners.

NOTE - To obtain accurate reading, shut off all other gas appliances connected to meter.

6-Burners

Burners are factory set for maximum air and cannot be adjusted. Always operate unit with access panel in place. A peep hole is furnished in the heating access panel for flame viewing. Natural gas should burn basically blue with some clear streaks. L.P. gas should burn mostly blue with some clear yellow streaks.

Figure 26 shows how to remove burner assembly.

- 1- Turn off electrical power and the gas supply to the unit.
- 2- Open the burner compartment access panel.
- 3- Remove screws securing burners to burner support and lift burners from the orifices. See figure 26 . Clean as necessary. Spark gap on ignition electrode must be properly set. See figure 21.
- 4- Replace burners and screws securing burner.
- 5- Replace the burner compartment access panel.
- 6- Turn on power and gas supply to unit. To begin operation see E- Heating Start Up in section III- .

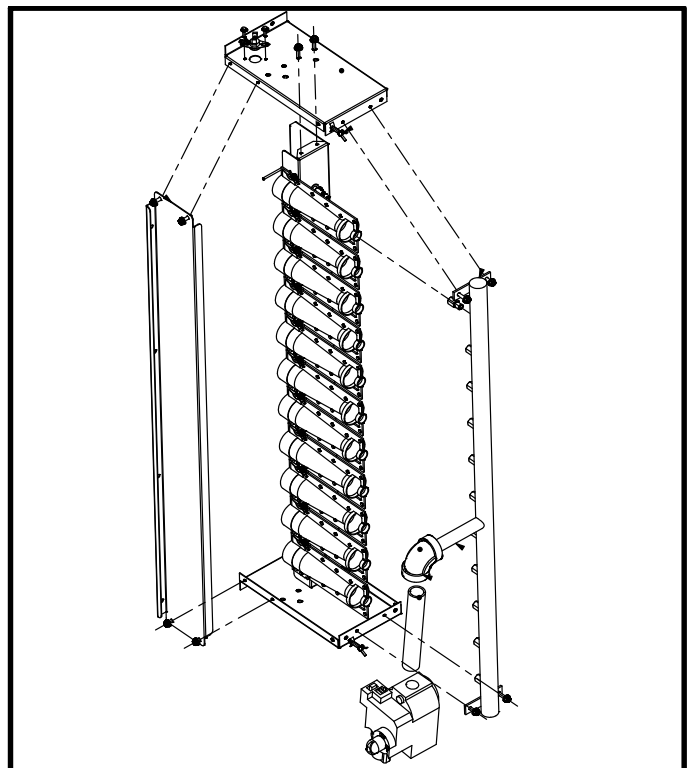

FIGURE 26

7-Heat Exchanger

To Access or Remove Heat Exchanger From Unit:

- 1- Turn off gas and electric power.
- 2- Remove access panel(s) and unit center mullion.
- 3- Remove gas valve, manifold assembly and burners.
- 4- Remove combustion air blower and flue box. Pay careful attention to the order in which gaskets and orifice are removed.
- 5- Support heat exchanger (to prevent it from falling when final screws are removed.)
- 6- Remove screws supporting heat exchanger and slide out.
- 7- To install heat exchanger, reverse procedure. Be sure to secure all wires and check plumbing and burner plate for airtight seal. Screws must be torqued to 35 in.-lbs. (155.7 N) to ensure proper operation.

8-Flame Sensing

Flame current is an electrical current which passes from the ignition control through the sensor electrode during unit operation. See table below for flame signal range. The electrodes should be located so the tips are at least 1/2" (12.7 mm) inside the flame envelope. Do not bend electrodes. To measure flame current, use the following procedure below:

NOTE-Electrodes are not field adjustable. Any alterations to the electrode may create a hazardous condition that can cause property or personal injury.

- 1- Disconnect power to unit.
- 2- Remove lead from sensing electrode and install a 0-50DC microamp meter in series between the sensing electrode and the sensing lead.
- 3- Reconnect power and adjust thermostat for heating demand.
- 4- When flame is established compare reading to table 12. Do not bend electrodes.
- 5- Disconnect power to unit before disconnecting meter. Make sure sensor wire is securely reconnected before reconnecting power to unit.

TABLE 12

Manufacturer	Nominal Signal	Drop Out
Utec	0.5-1.0	0.4
Fenwal	0.7-1.2	0.7

NOTE-If the meter scale reads 0, the leads are reversed. Disconnect power and reconnect leads for proper polarity.

B-Cooling System Service Checks

All units are factory charged and require no further adjustment; however, charge should be checked periodically using the normal operating pressure method.

1-Gauge Manifold Attachment

Service gauge ports are identified in figure 5. Attach high pressure line to discharge line Schrader port and the low pressure line to the suction line Schrader port.

NOTE-When unit is properly charged discharge line pressures should approximate those in tables 5 through 10.

V-MAINTENANCE

⚠ CAUTION

Electrical shock hazard. Turn off power to unit before performing any maintenance, cleaning or service operation on the unit.

A-Filters

Units are equipped with eleven 16 X 25 X 2" (406 x 635 x 51 mm) or 16 x 25 x 4" (406 x 635 x 102 mm) filters. Filters should be checked monthly and replaced when necessary with filters of like kind and size. Take note of air flow direction marking on filter frame when reinstalling filters. Orient filters as shown in figure 27.

NOTE-Filters must be U.L.C. certified or equivalent for use in Canada.

Units equipped with optional outdoor air intake hoods contain four 20 X 25 X 2" (508 X 635 X 51 mm) aluminum cleanable filters. See figure 28 for location of filters. On horizontal air discharge installations, remove two screws and pivot screen to access filters. See figure 29.

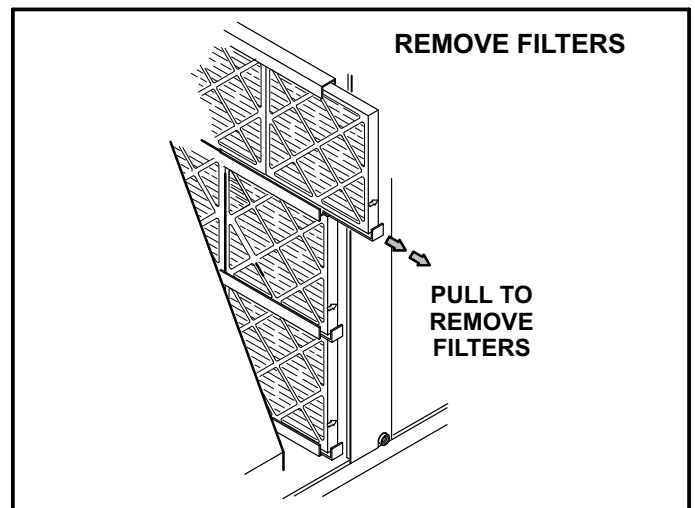

FIGURE 27

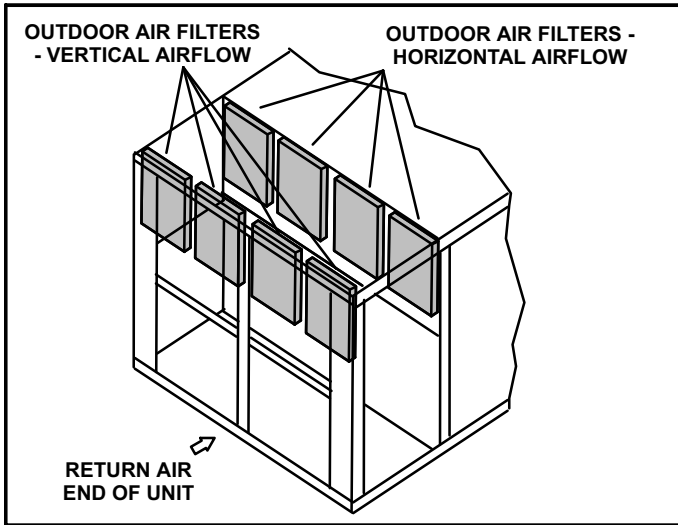

FIGURE 28

B-Lubrication

All motors are lubricated at the factory. No further lubrication is required.

Blower shaft bearings are prelubricated. For extended bearing life, relubricate at least once every two years with a lithium base grease, such as Alvania 3 (Shell Oil), Chevron BRB2 (Standard Oil) or Regal AFB2 (Texas Oil). Use a hand grease gun for relubrication. Add only enough grease to purge through the bearings so that a bead of grease appears at the seal lip contacts.

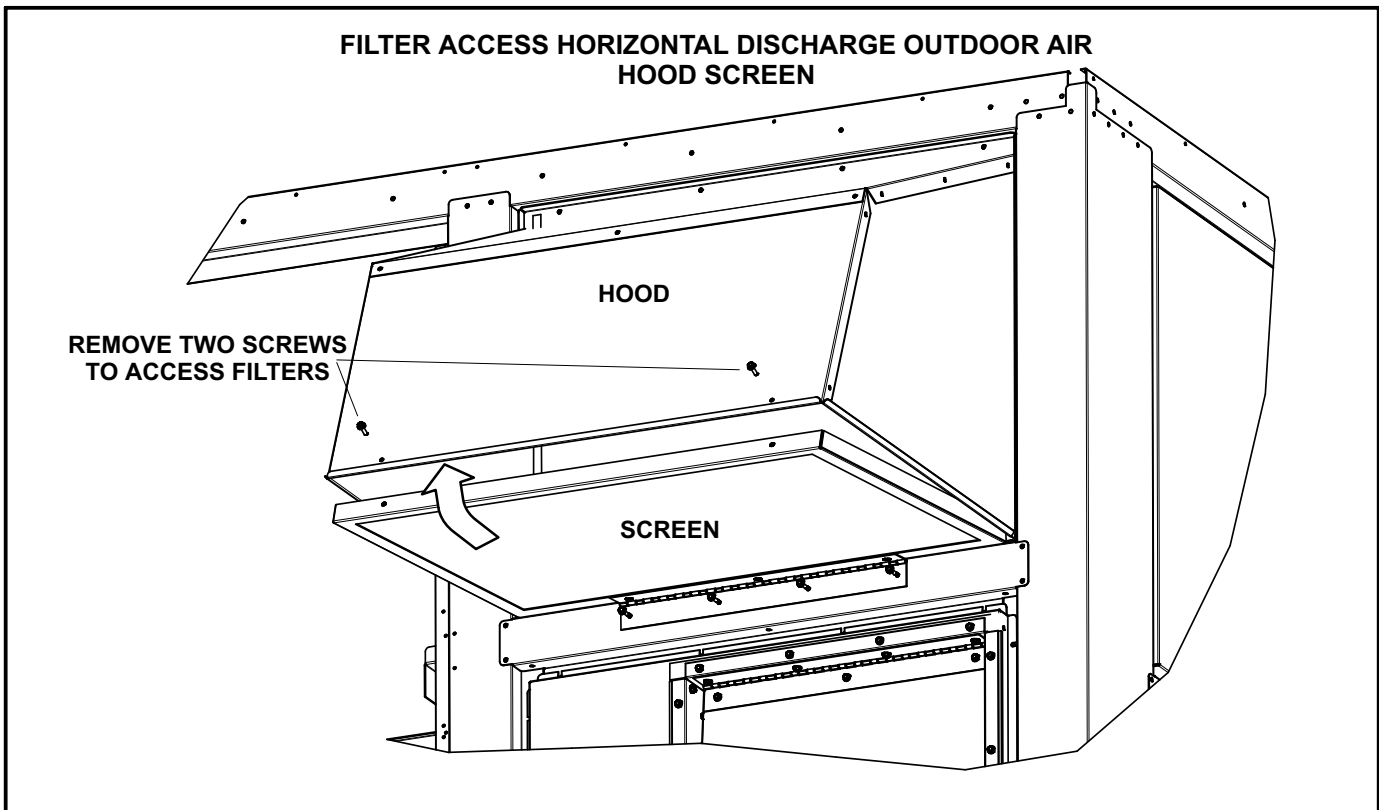

FIGURE 29

⚠ CAUTION

Be careful when servicing unit to avoid accidental contact with sharp metallic edges which may cause personal injury.

G-Supply Air Blower Wheel

Annually inspect supply air blower wheel for accumulated dirt or dust. Turn off power before attempting to remove access panel or to clean blower wheel. If balancing clips are removed, make sure they are reinstalled in the same location when cleaning is completed.

NOTE-Do not lose balancing clips.

D-Evaporator Coil

Inspect and clean coil at beginning of each season. Clean using mild detergent or commercial coil cleanser. Check condensate drain pan and line, if necessary. Flush coil and condensate drain with water taking care not to get insulation, filters and return air ducts wet. Check connecting lines and coil for evidence of oil and refrigerant leaks.

E-Condenser Coil

Clean condenser coil annually with detergent or commercial coil cleaner and inspect monthly during the cooling season. Check connecting lines and coil for evidence of oil and refrigerant leaks.

NOTE-If owner complains of insufficient cooling, the unit should be gauged and refrigerant charge checked. Refer to Gauge Manifold Attachment and Charging sections in this manual.

F-Electrical

- 1- Check all wiring for loose connections.
- 2- Check for correct voltage at unit (unit operating).
- 3- Check amp-draw on both condenser fan motor and blower motor.

G-Burners

- 1- Periodically examine burner flames for proper appearance during the heating season.
- 2- Before each heating season examine the burners for any deposits or blockage which may have occurred.
- 3- Remove burners as shown in section IV-SYSTEM SERVICE CHECKS figure 26 and clean as necessary. Replace burners and check spark gap.

H-Combustion Air Inducer

Under normal operating conditions, the combustion air inducer wheel should be checked and cleaned prior to the heating season. However, it should be examined periodically during the heating season to establish an ideal cleaning schedule. With power supply disconnected, the condition of the inducer wheel can be determined by looking through the vent opening.

Clean combustion air inducer as follows:

- 1- Shut off power supply and gas to unit.
- 2- Disconnect prove switch air tubing from combustion air inducer port.
- 3- Remove and retain screws securing combustion air inducer to flue box. Remove and retain the screw securing the combustion air inducer to the vent connector. See figure 30.
- 4- Clean inducer wheel blades with a small brush and wipe off any dust from housing. Clean accumulated dust from front of flue box cover.
- 5- Return combustion air inducer motor to the original location and secure with retained screws. It is recommended that the combustion air inducer gasket be replaced during reassembly.
- 6- Clean combustion air inlet screen on heat access panel using a small brush.

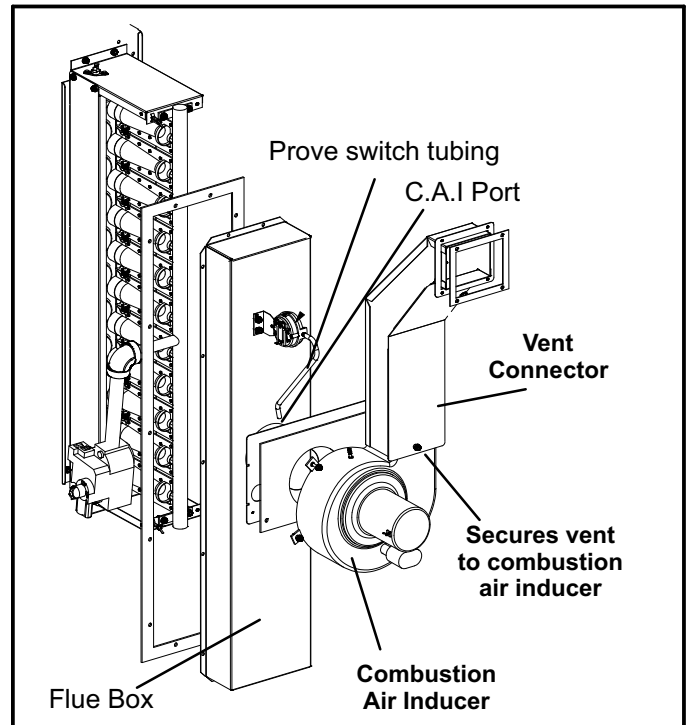

FIGURE 30

I-Flue Passageway and Flue Box

- 1- Remove combustion air inducer assembly as described in section H-.
- 2- Remove flue box cover. Clean with a wire brush as required.

- 3- Remove flue baffle retaining bracket and pull tube baffles from heat exchanger tubes. Clean tubes and baffles with a wire brush. Figure 14 shows a more detailed view of the heat exchanger.
- 4- Reinsert tube baffles, secure baffle retaining bracket and reassemble the unit. The flue box cover gasket and combustion air inducer gasket should also be replaced during reassembly.

VI-ACCESSORIES

The accessories section describes the application of most of the optional accessories which can be factory or field installed to either the LGH/LCH units.

A- S1CURB Mounting Frame

When installing the LGH/LCH units on a combustible surface, S1CURB roof mounting frame is used. The roof mounting frames are recommended in all other applications but not required. If the units are not mounted on a flat (roof) surface, they MUST be supported under all edges and under the middle of the unit to prevent sagging. The units MUST be mounted level within 1/16" per linear foot or 5mm per meter in any direction.

The assembled S1CURB mounting frame is shown in figure 32. Refer to the roof mounting frame installation instructions for details of proper assembly and mounting. The roof mounting frame MUST be squared to the roof and level before mounting. Plenum system MUST be installed before the unit is set on the mounting frame. Typical roof curbing and flashing is shown in figure 31. Refer to the roof mounting frame installation instructions for proper plenum construction and attachment.

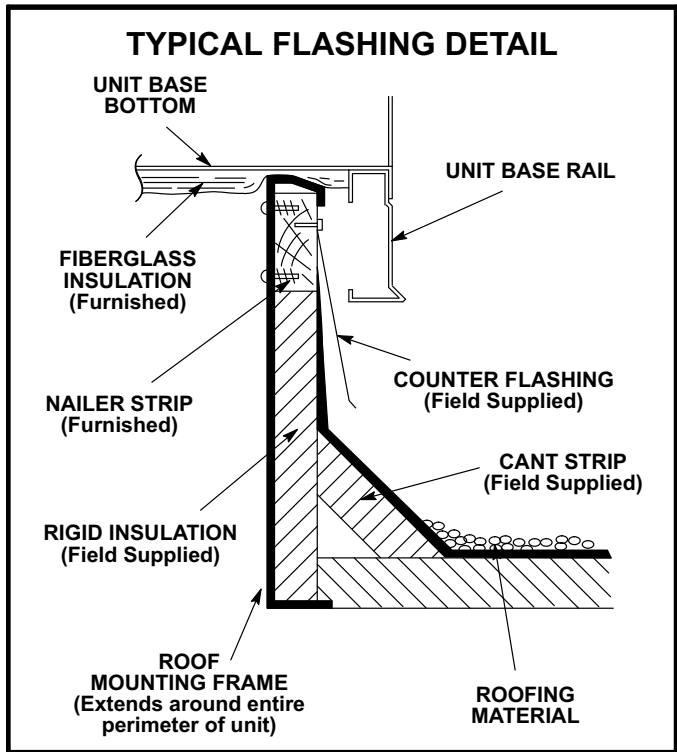

FIGURE 31

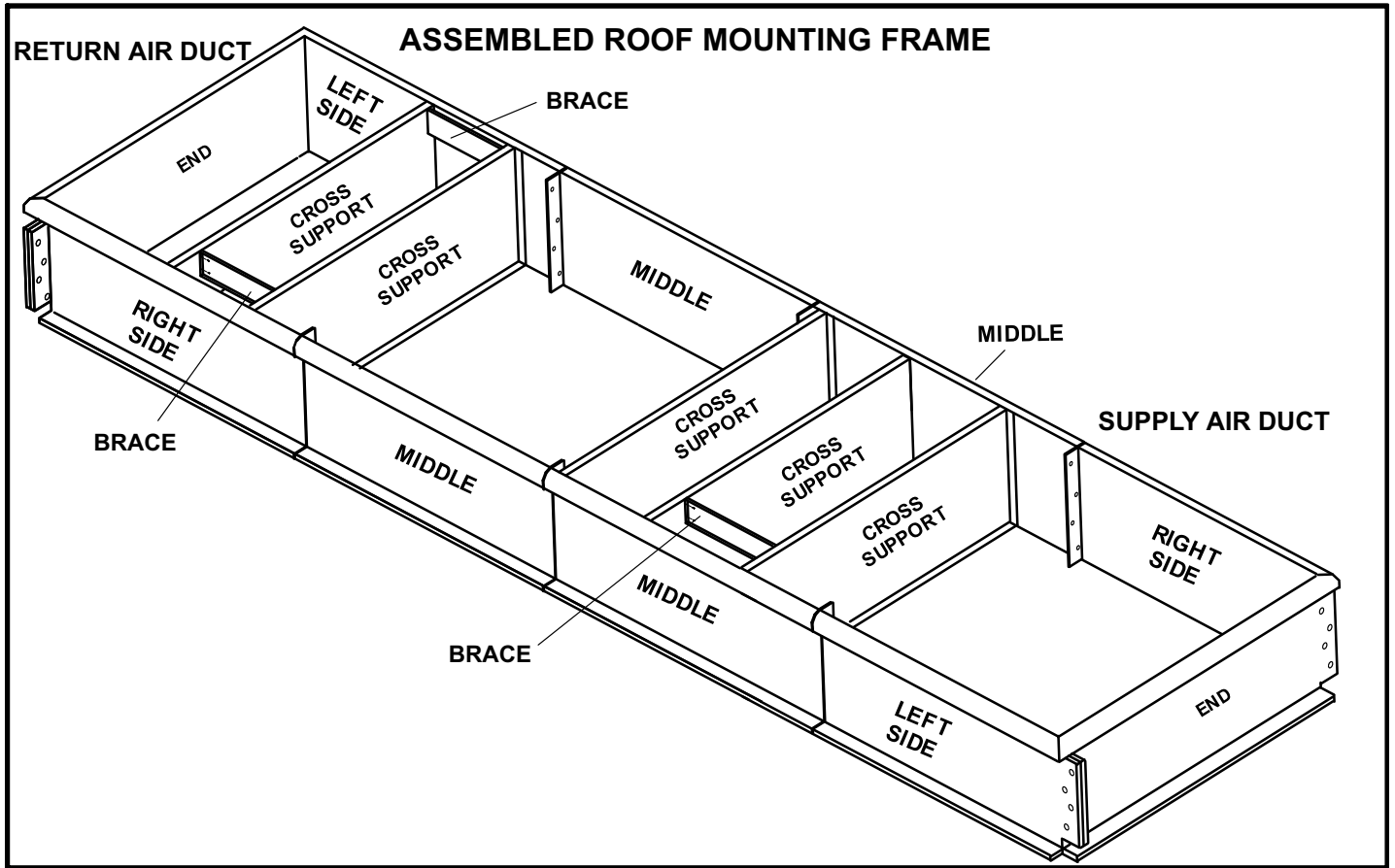

FIGURE 32

B- Outdoor Air Dampers

Dampers may be manually or motor (M) operated to allow up to 25 percent outside air into the system at all times . Either air damper can be installed in LGH/LCH units. Washable filter supplied with the outdoor air dampers can be cleaned with water and a mild Detergent and should be sprayed with Filter Handicoater when dry prior to reinstallation. Filter Handicoater is R.P. Products coating no. 418 and is available as Part No. P-8-5069.

**C-Economizer
(Factory Installed)**

Unit may contain an optional modulating economizer controlled by the A55 Unit Controller. Economizer dampers modulate open to use outdoor air for free cooling when temperature is suitable during the occupied time period. Refer to economizer section of unit installation instruction for set up and operation.

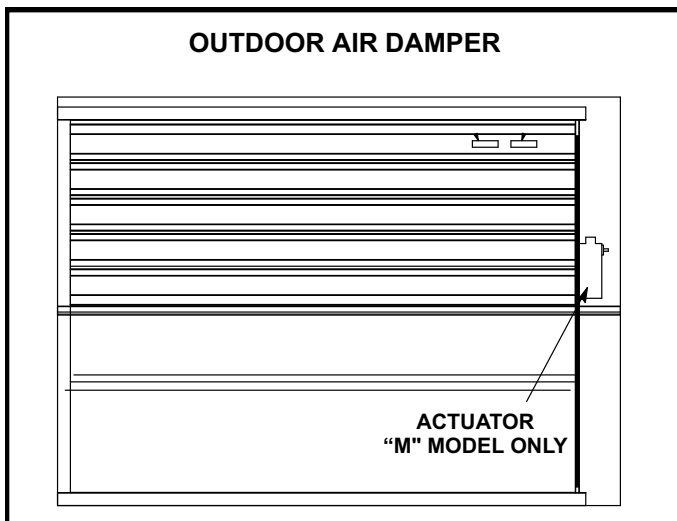

FIGURE 33

Units Equipped With An Energy Recovery Wheel

The economizer minimum damper position must be adjusted to allow for the air resistance of the ERW.

- 1- Determine the required outdoor air CFM.
- 2- Apply the CFM to table 13 to determine the target static pressure drop across the ERW.
- 3- Measure the static pressure drop across the ERW. See figure 34.
- 4- Adjust the damper to minimum position open.
- 5- Read the static pressure drop across the ERW and adjust the damper position as needed to reach the target pressure drop.

For example, a unit with an outdoor air flow of 6500 CFM would require an ERW pressure drop of 0.9" w.c.

TABLE 13

Outdoor Flow - cfm	Static Pressure - in. w.c.
3250	0.45
3500	0.48
3750	0.52
4000	0.55
4250	0.59
4500	0.62
4750	0.66
5000	0.69
5250	0.73
5500	0.76
5750	0.80
6000	0.83
6250	0.87
6500	0.90
6750	0.94
7000	0.97
7250	1.01
7500	1.04
7750	1.08
8000	1.11
8250	1.15
8500	1.18
8750	1.22
9000	1.25

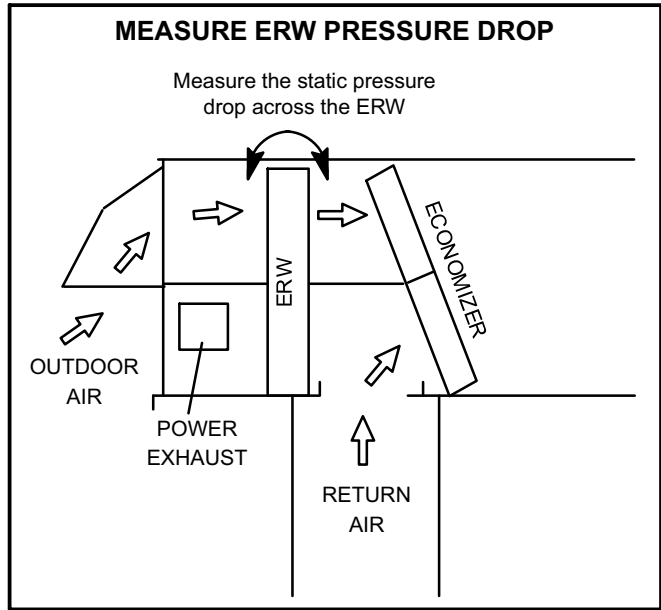

FIGURE 34

D-Supply Air Variable Frequency Drive (VAV units only)

NOTE - Units equipped a Variable Frequency Drive (VFD) are designed to operate on balanced, three-phase power. Operating units on unbalanced three-phase power will reduce the reliability of all electrical components in the unit. Unbalanced power is a result of the power delivery system supplied by the local utility company. Factory-installed inverters are sized to drive blower motors with an equivalent current rating using balanced three-phase power. If unbalanced three-phase power is supplied; the installer must replace the existing factory-installed inverter with an inverter that has a higher current rating to allow for the imbalance. Refer to the installation instructions for additional information and available replacements.

LGH/LCH VAV units will contain a supply air blower equipped with a variable frequency drive A96 (VFD) which varies supply air CFM. As duct static increases, the supply air volume will decrease. As duct static decreases, the supply air volume will increase.

The Unit Controller uses input from a field-installed pressure transducer (A30) to maintain a 1.0" w.c. (default) static pressure. Refer to the Unit Controller manual Parameters 386, 387, 388 and 389 to adjust the static pressure setpoint. Install the transducer according to manufacturer's instructions.

Note - Make sure the transducer is installed in the main duct at least 2/3 of the distance away from the unit.

The supply air VFD (A96) is located on the front side of the unit in the return air compartment. See figure 35.

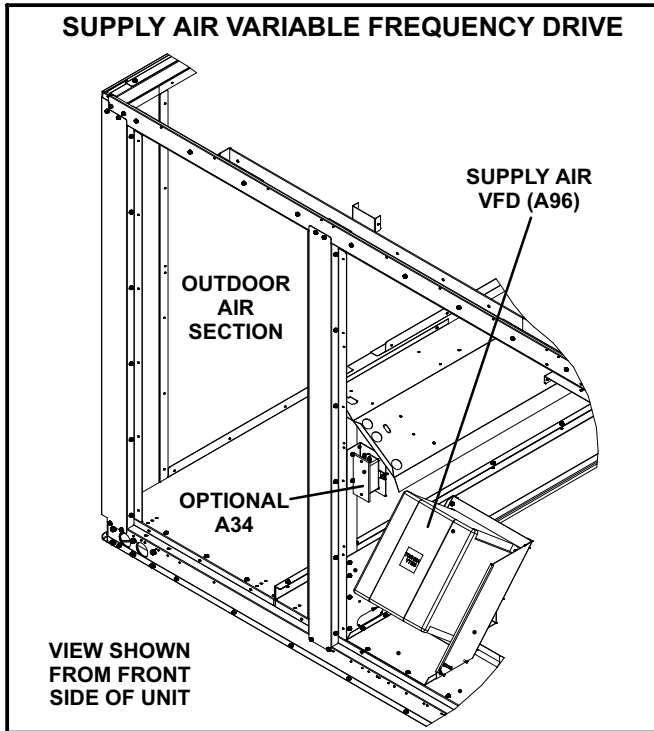

FIGURE 35

Excessive Duct Static

The Unit Controller will lock-out the unit for 5 minutes if static pressure exceeds 2.0" w.c. for 20 seconds (default). The Unit Controller will permanently shut down the unit after three occurrences. Use the following parameters to adjust the default values:

Parameter 110: Error time off delay.

Parameter 42: Air supply static shutdown set point.

Parameter 43: Static pressure lockout counter set point.

Optional field-installed high pressure switch (S155) will de-energize the unit above static pressure setpoint. Set cut-out pressure at 2" w.c. unless otherwise specified. Switch must be manually reset.

Supply Air VFD By-Pass Plug (Optional)

The supply air VFD may be by-passed using jack/plug connections. Locate J/P198 connectors in control box area under the relays. Disconnect J198 from P198 and connect J204 to P198. See figure 36. Blower will operate in constant air volume mode.

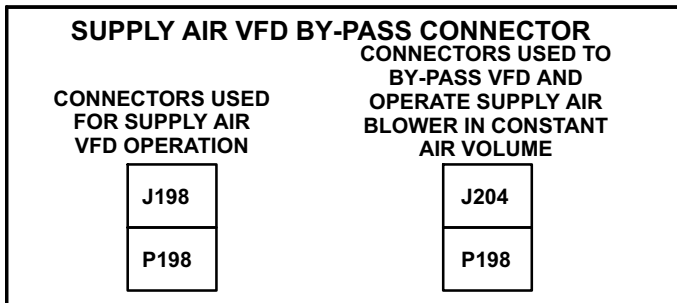

FIGURE 36

E-Gravity Exhaust Dampers

Gravity exhaust dampers are used with LGH/LCH series units. The dampers are installed in the return air compartment of the unit. The dampers must be used any time power exhaust blowers or fans are applied to LGH/LCH series units and are optional with an economizer.

F-Power Exhaust Blowers & Fans

Power exhaust blowers and fans are used with LGH /LCH series units. Power exhaust blowers and fans provide exhaust air pressure relief.

LGH/LCH units may contain one or two power exhaust fans or blowers. Exhaust blowers are shown in figure 37. Exhaust fans are located in the same place and discharge air in the same direction.

Power exhaust equipped with two fans or blowers is operated in two stages. Power exhaust blowers may be equipped with a variable frequency drive (VFD) to vary exhaust air CFM. VFD applications require a factory-installed General Purpose GP3 control board A187.

The Unit Controller will use damper position or building static pressure to initiate power exhaust. Any time building static is used to initiate power exhaust, a GP3 board is required for operation.

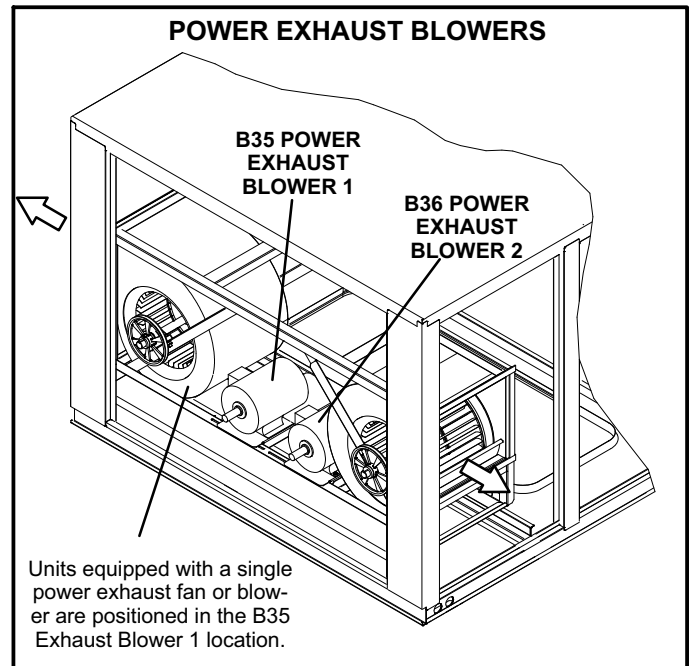

FIGURE 37

General Purpose GP3 Board W/TB18

The GP3 board is positioned on the A55 Unit Controller in the control box area. Only one board is required regardless of the number of VFD and power exhaust functions.

Optional Power Exhaust Variable Frequency Drive

Power Exhaust VFD (A137) will increase exhaust air CFM when building pressure is higher than setpoint and decrease the volume when building pressure is lower than setpoint. The default setpoint is .05"w.c.

Power exhaust VFD is available with one or two blowers; only one VFD is required. The power exhaust VFD is located in the return air compartment on the back side of the unit. See figure 38.

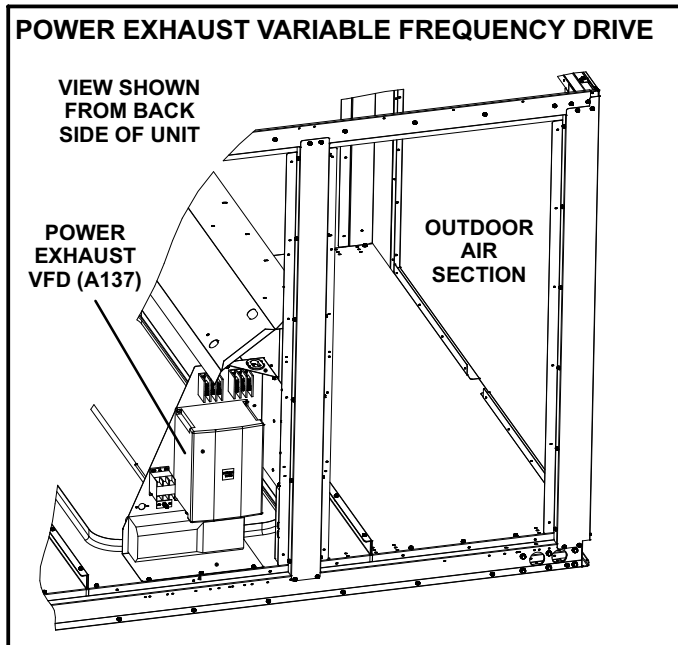

FIGURE 38

Power Exhaust Control Options

Damper Position

The Unit Controller will initiate stage 1 power exhaust when economizer or outdoor air damper travel reaches 50%. The Unit Controller will initiate stage 2 power exhaust when economizer or outdoor air damper travel reaches 75%. Refer to the Unit Controller manual parameter 215 and 219 to adjust the default setting.

Pressure Switches (S37 and S39)

Field-installed switches are used to sense the static pressure difference between outdoor air and building air. Power exhaust equipped with one fan or blower use one switch (S37). Power exhaust equipped with two fans uses both switches.

Stage 1 power exhaust will be energized above .05"w.c. (default) building static pressure. Stage 2 power exhaust will be energized if building static pressure rises above .01"w.c. (default). Use parameter 217 to adjust stage 1 setpoint and parameter 221 to adjust stage 2 setpoint.

Install the switches according to manufacturer's instructions. Use an Outdoor Kit on the outdoor (reference) air tubing to prevent pressure fluctuations due to wind gusts.

Pressure Transducer (A34)

The optional factory-installed pressure transducer is used to sense the static pressure difference between outdoor air and building air. The transducer is located in the return air section of unit near the supply air VFD (A96). See figure 35. Only one pressure transducer is needed regardless of number of exhaust blowers.

Stage 1 power exhaust constant air volume will be energized above 0.1"w.c. (default) building static pressure. Stage 2 power exhaust constant air volume will be energized if building static pressure rises above 0.2"w.c. (default). Use parameter 217 to adjust stage 1 setpoint and parameter 221 to adjust stage 2 setpoint. Power exhaust equipped with a VFD will vary the CFM output to maintain a building static pressure of .05"w.c.

Complete transducer installation as follows:

- 1- Connect field-provided 1/4" tubing to the (+) port on the transducer. Route tubing through unit return air opening to a return air diffuser in the ductwork.
- 2- Locate the outdoor air kit shipped in a box in the blower section on the back side of the unit. Install outdoor air kit on the top of the unit in location shown in figure 39. Use manufacturer's instructions.

Note - Outdoor kit reduces fluctuations in reference reading due to wind gusts.

- 3- Locate the tubing provided with the outdoor air kit. Route the tubing from the outdoor kit through the hole under the intake hood to A34 as shown in figure 39. Connect tubing to the (-) port on the transducer. Coil and secure excess tubing - do not cut.

ROUTE TUBING TO OUTDOOR (REFERENCE) AIR

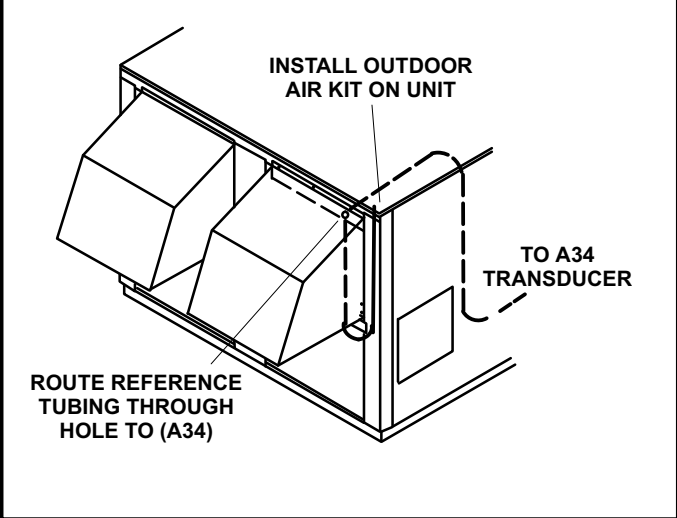

FIGURE 39

Power Exhaust VFD By-Pass Plug (Optional)

The power exhaust VFD may be by-passed using jack/plug connections. Locate J/P211 connectors in control box area under the relays. Disconnect J211 from P211 and connect J215 to P211. See figure 40. Exhaust blower will operate at maximum speed.

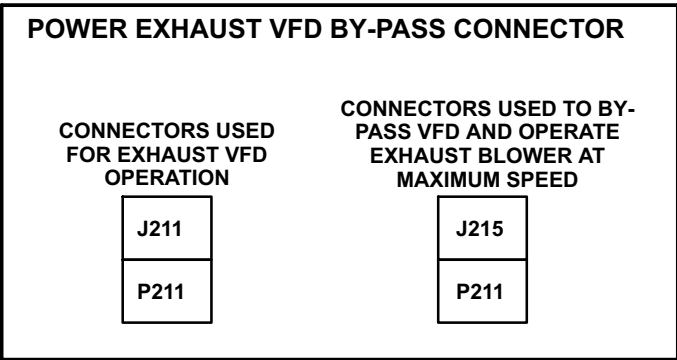

FIGURE 40

G-Control Systems

The A55 Unit Controller provides all control function for the rooftop unit. Default operation requires a standard room thermostat or direct digital controller (DDC). The A55 can also control the unit from a zone temperature sensor. The A55 Unit Controller is a network controller when daisy-chained to the L Connection Network Control System. For ease of configuration, the A55 can be connected to a PC with Unit Controller PC software installed.

H-Smoke Detectors A17 and A64

Photoelectric smoke detectors are a factory installed option. The smoke detectors can be installed in the supply air section (A64), return air section (A17), or in both the supply and return air section. Wiring for the smoke detectors are shown on the temperature control section (C2) wiring diagram in back of this manual.

I-Energy Recovery Wheel

LGH/LCH units may contain an optional energy recovery wheel. The ERW is located in the outdoor air entering and exhaust air streams. In the heating mode, the wheel rotates to transfer heat from the exhaust air stream to the outdoor air intake air stream. In the cooling mode the process reverses. See figure 41.

The ERW motor (B28) is energized when outdoor air is above 65°F (monitored by S125), or below 40°F monitored by S23). Between the temperature range of 40°F and 65°F the wheel does not operate. This range is for economizer operation. Thermostats S125 and S23 are located on a panel above the inverter for the indoor blower. Refer to wiring diagram on unit panels.

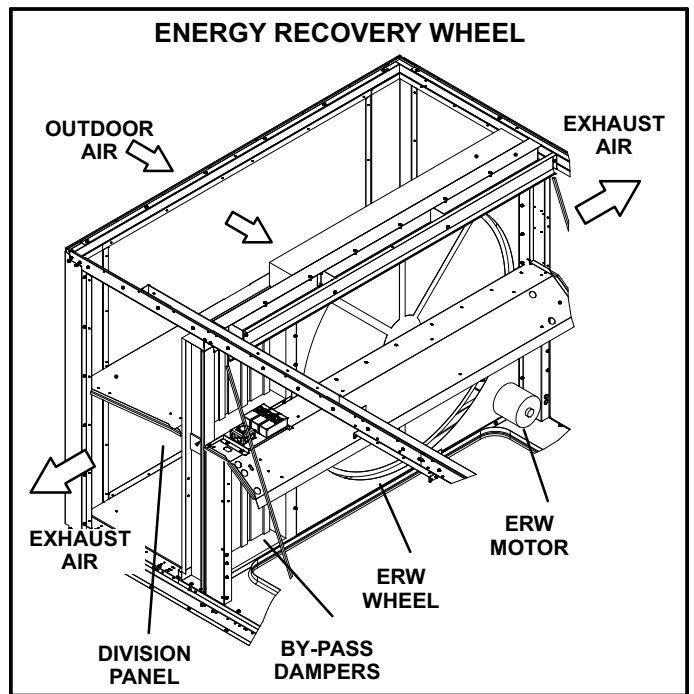

FIGURE 41

Note - When the outdoor air temperature is between 65°F and 40°F, DL43 will energize the ERW for one minute every ten minutes to clean the wheel.

The adjustable S36 end switch will energize by-pass dampers open as outdoor air dampers open. By-pass dampers will close as outdoor air dampers close or move to minimum position.

ERW should operate on unit start-up unless the outdoor temperature is between 40°F and 65°F. When outdoor air temperature is between 40°F and 65°F, install a jumper between S125 thermostat terminal "R" and K94 relay coil terminal "A" to check ERW operation.

J-Blower Proving Switch S52

The blower proving switch monitors blower operation and locks out the unit in case of blower failure. The switch is N.O. and closes at 0.14" W.C. (34.9 Pa) The switch is mounted on the upper left hand corner of the blower deck. Wiring for the blower proving switch is shown on the temperature control section (C2) wiring diagram in back of this manual.

K-Dirty Filter Switch S27

The dirty filter switch senses static pressure increase indicating a dirty filter condition. The switch is N.O. and closes at 1" W.C. (248.6 Pa) The switch is mounted on the top filter channel corner. Wiring for the dirty filter switch is shown on the temperature control section (C2) wiring diagram in back of this manual. Actuation of this switch does not affect unit operation.

L-Indoor Air Quality (CO₂) Sensor A63

The indoor air quality sensor monitors CO₂ levels and reports the levels to the A55 Unit Controller. The board adjusts the economizer dampers according to the CO₂ levels. The sensor is mounted next to the indoor thermostat or in the return air duct. Refer to the indoor air quality sensor installation instructions for proper adjustment. Wiring for the indoor air quality switch is shown on the temperature control section (C2) wiring diagram in back of this manual.

M-Drain Pan Overflow Switch S149 (optional)

The overflow switch is used to interrupt cooling operation when excessive condensate collects in the drain pan. The N.O. overflow switch is controlled by K220 and DL46 relays, located in the unit control panel. When the overflow switch closes, 24VAC power is interrupted and after a five-second delay unit compressors are de-energized. Once the condensate level drops below the set level, the switch will open. After a five-minute delay the compressor will be energized.

N-Factory-Installed Humiditrol

General

Humiditrol units provide a dehumidifying mode of operation. These units contain a reheat coil adjacent to and downstream of the evaporator coil. Reheat coil solenoid valves, L14 and L30, route hot discharge gas from the compressor to the reheat coil. Return air pulled across the evaporator coil is cooled and dehumidified; the reheat coil adds heat to supply air.

See figure 42 for reheat refrigerant routing.

L14 and L30 Reheat Coil Solenoid Valves

When Unit Controller input (P269-9) indicates room conditions require dehumidification, L14 and L30 reheat valves are energized and refrigerant is routed to the reheat coil.

Reheat Setpoint

Reheat is factory-set to energize when indoor relative humidity rises above 60% (default). Reheat will terminate when the indoor relative humidity falls 3% below setpoint, or 57% (default). The reheat setpoint can be adjusted by changing parameter 106. A setting of 100% will disable reheat. The reheat setpoint can also be adjusted using an optional Network Control Panel (NCP).

A91 Humidity Sensor

Relative humidity should correspond to the sensor (A91) output voltage listed in table 14. For example: if indoor air relative humidity is 80% \pm 3%, the humidity sensor output should read 8.00VDC.

Check the sensor output annually for accuracy. Keep the air intake openings on the sensor clean and free of obstructions and debris.

Read Relative Humidity At Unit Controller

When relative humidity sensor is installed, the relative humidity percentage can be displayed on the M3 unit controller and over the L Connection network via the network control panel or computer software client.

TABLE 14

Relative Humidity (%RH \pm 3%)	Sensor Output (VDC)
20	2.00
30	3.00
40	4.00
50	5.00
60	6.00
70	7.00
80	8.00
90	9.00

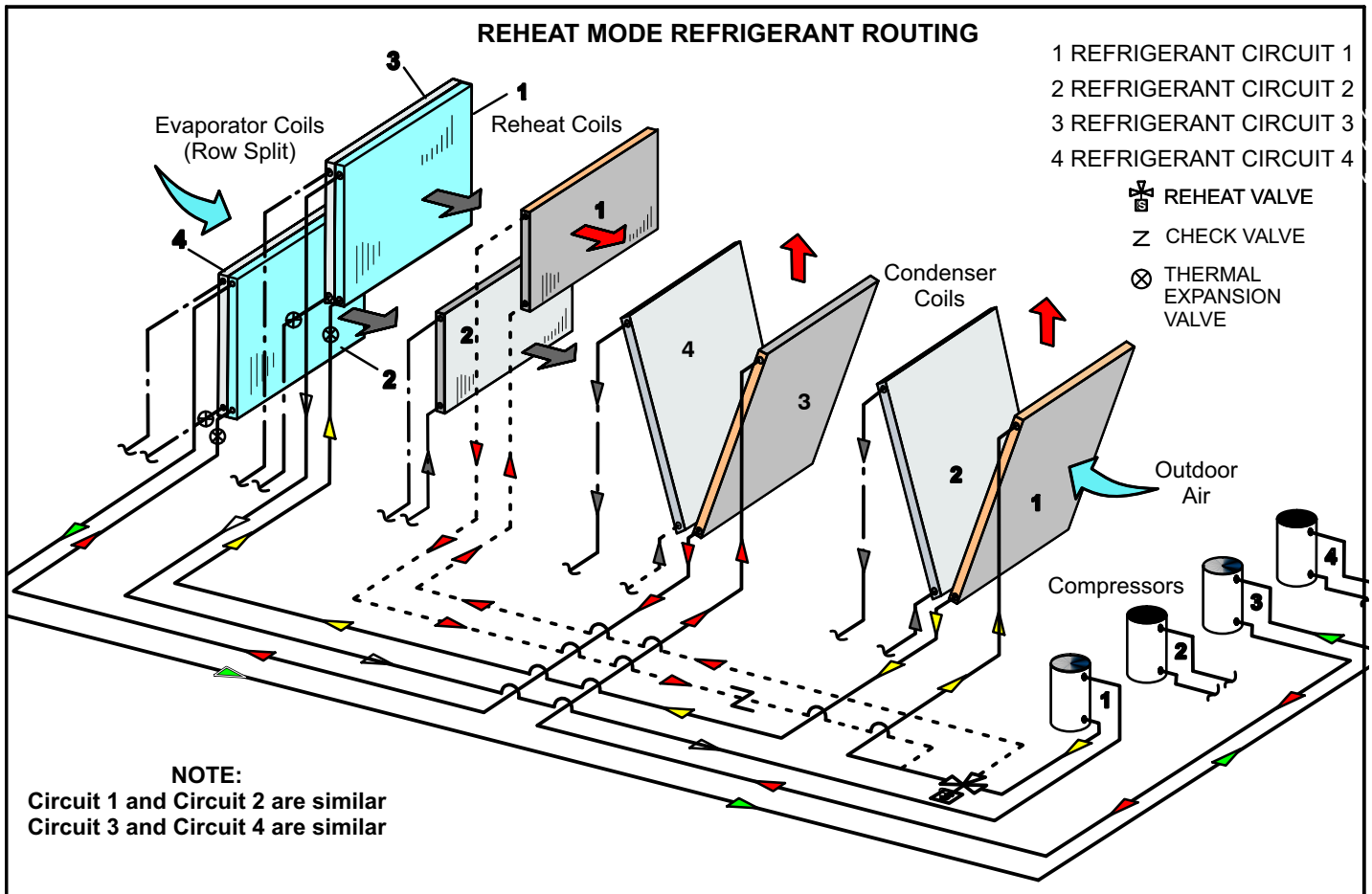

FIGURE 42

Check-Out

Test Humiditrol operation using the following procedure.

- 1- Make sure reheat is wired as shown in wiring section.
- 2- Make sure unit is in local thermostat mode.
- 3- Select Unit Controller *Service - Test - Dehumidifier 1 & 2*. The blower, compressor 1 and compressor 2 (reheat) should be operating. L14 and L30 LED's on the Unit Controller should also be ON, indicating the reheat valves are energized. Reheat mode will appear on the Unit Controller display.
- 4- De-Select Unit Controller *Service - Test - Dehumidifier 1 & 2*. Compressor 1 and 2 (reheat) should de-energize, L14 and L30 LED's should go OFF, blower should still be energized.

Reheat Operation

The following conditions must be met before reheat will be energized:

- 1- Blower must be operating.
- 2- System must be in occupied mode.

- 3- System must NOT be operating in heating mode.
- 4- One cooling demand is required if the unit has been in heating mode, the Unit Controller has been reset, or at initial unit start-up.

IMPORTANT - Free cooling does not operate during reheat. Free cooling will operate as shown in the Unit Controller manual.

Reheat will operate as shown in table 15.

For other reheat control options, refer to the Unit Controller manual.

Units are shipped from the factory to provide two stages of cooling.

Three stages of cooling is available by installing a transfer relay and a three-stage thermostat.

Four stages of cooling is available in zone sensor mode.

Compressors are not de-energized when unit operation changes from cooling to reheat or from reheat to cooling. Instead, L14 and L30 reheat valves are energized (reheat) or de-energized (cooling).

**TABLE 15
REHEAT OPERATION**

Two-Stage Thermostat (2 Cooling Stages, Y1, Y2) -4 Compressors Models:												
Demand		Compressors				Blower Speed				Econ Pos	RH Valve	
T'stat	Hum	1	2	3	4	C1	C2	C3	C4		1	2
	Yes	On	On	Off	Off	X				Min	On	On
Y1	Yes	On	On	Off	Off				X	Min	On	On
Y2	Yes	On	On	Off	Off				X	Min	Off	Off
Three-Stage Thermostat (3 Cooling Stages Y1, Y2, Y3)- 4 Compressor Models:												
Demands		Compressors				Blower Speed				Econ Pos	RH Valve	
T' stat	Hum	1	2	3	4	C1	C2	C3	C4		1	2
	Yes	On	On	Off	Off	X				Min	On	On
Y1	Yes	On	On	On	Off				X	Min	On	On
Y2	Yes	On	On	On	On				X	Min	On	Off
Y3	Yes	On	On	On	On				X	Min	Off	Off
Zone Sensor (4 Cooling Stages Y1, Y2, Y3, Y4) - 4 Compressors												
Demands		Compressors				Blower Speed				Econ Pos	RH Valve	
T'stat	Hum	1	2	3	4	C1	C2	C3	C4		1	2
	Yes	On	On	Off	Off	X				Min	On	On
Y1	Yes	On	On	Off	Off				X	Min	On	On
Y2	Yes	On	On	Off	Off				X	Min	On	On
Y3	Yes	On	On	Off	Off				X	Min	On	Off
Y4	Yes	On	On	Off	Off				X	Min	Off	Off

- 1- Blower must be operating.
- 2- System must be in occupied mode.
- 3- System must NOT be operating in heating mode.
- 4- One cooling demand is required if the unit has been in heating mode, the Unit Controller has been reset, or at initial unit start-up.

O-Modulating Gas Valve (MGV)

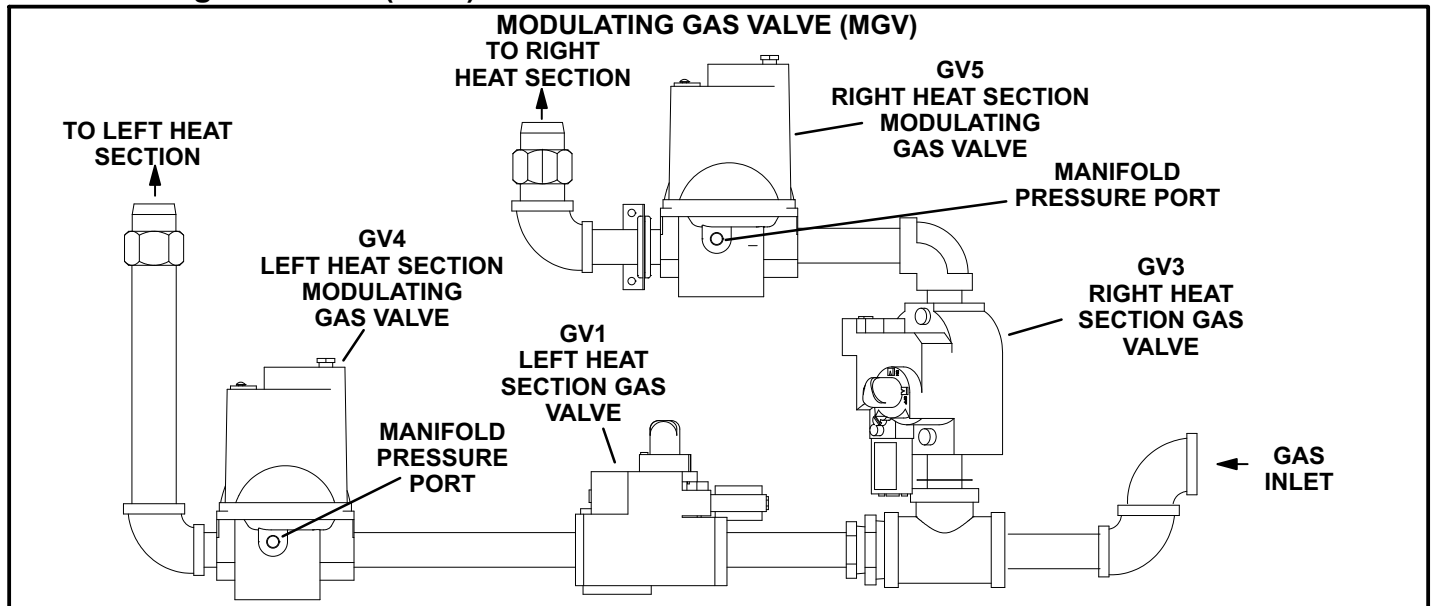

FIGURE 43

Units equipped with optional modulating gas valves (MGV) contain two modulating gas valves in addition to two standard gas valves. See figure 43.

Operation

The Unit Controller will control modulating gas valves to maintain 110°F (default) discharge air during the heating cycle. The left heat section will operate when 25-50% of nameplate heat is needed. Both heat sections will operate when 50-100% of the nameplate heat is needed.

The normally open MGV will allow full heating capacity should the MGV fail.

Start-Up

- 1- Operate the unit in heating mode according to the Heating Start-Up section in this manual.
- 2- After the unit has operated for 5 minutes navigate the following menu path on the unit controller: MAIN MENU -> SERVICE -> TEST -> HEAT -> HEAT 2. The unit will operate at maximum heating capacity.
- 3- Measure the manifold pressure at the gas valves. Manifold pressures should be:

GV1 & GV3:	Natural - 4.0"w.c.	LP - 10.8"w.c.
GV4 & GV5:	Natural - 3.7"w.c.	LP - 10.5"w.c.
- 4- After the unit has operated for 5 minutes navigate the following menu path on the unit controller: MAIN MENU -> SERVICE -> TEST -> HEAT -> HEAT 1. The unit will operate at minimum heating capacity.
- 5- Measure the manifold pressure at the gas valves. Manifold pressures should be:

GV1 & GV3:	Natural - 4.0"w.c.	LP - 10.8"w.c.
GV4 & GV5:	Natural - 0.9"w.c.	LP - 2.6"w.c.

NOTE - BOTH OPT1 AND OPT2 SWITCHES MUST BE OFF FOR NORMAL UNIT OPERATION.

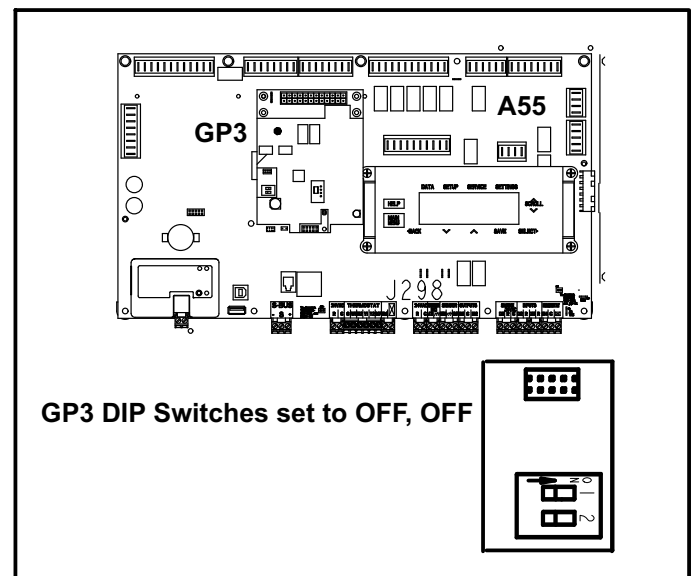
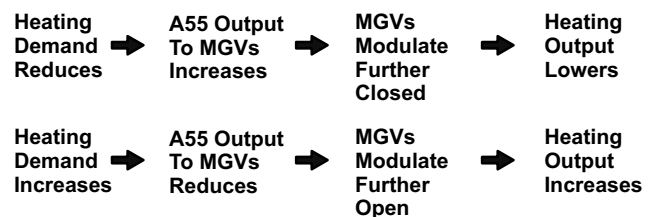

FIGURE 44

Unit Controller Output

The Unit Controller 0-10VDC output to the MGVs increases to modulate valves further closed during a reduced heating demand. The Unit Controller 0-10VDC output to the MGVs decreases to modulate valves further open during a higher heating demand.



P-Outdoor Air CFM Control

Outdoor air CFM Control is a factory-installed option available on units equipped with a supply air variable frequency drive (VFD) and economizer.

The Unit Controller modulates outdoor air dampers to maintain a constant amount of outdoor air regardless of blower speed. This ensures minimum ventilation requirements are met at lower supply air volumes.

The Unit Controller uses a velocity sensor (A24) that connects to P298 on A55 unit controller to modulate dampers. The sensor is located in the outdoor air stream. See figure 45.

Configuring ID Settings

- 1- Enable the Outdoor Air Control feature and set the velocity sensor range using the M3 Unit Controller **SETUP > INSTALL** menu. Navigate to **Configuration ID 1**. Set position **8** to:

H - Outdoor air control installed with A24 control set for low range (0-1968ft/min)

Note - The configuration ID velocity range must be set to "H" and the jumper setting on the A24 control must be set at low range. No other combinations may be used with the 100501-02 sensor. The jumper is factory-set at low range (0-1968ft/min)

- 2- Operate the blower in high speed and adjust the minimum damper position. Use **SETUP > TEST & BALANCE > DAMPER > MIN DAMPER POSITION** menu. Adjust minimum damper position and press **SAVE**. The Unit Controller will automatically save and display the velocity setpoint. Press **SAVE** again to confirm.

Note - The minimum damper position setting MUST be set lower than the OAC max damper position setting (50% default). To modify the max damper position setting, navigate to SETTINGS > EDIT PARAMETERS and select parameter 117 (DCV MAX DAMPER OPEN).

Additional outdoor air CFM control settings are available. See parameters 117 and 134 in the Unit Controller manual. Make adjustments through the **SETTINGS > EDIT PARAMETERS** menu; select the required parameter.

- 3- Replace A24 control cover.

Velocity Sensor Settings

The A24 control is factory-set for 0-10m/s. (0-1968ft/min.)

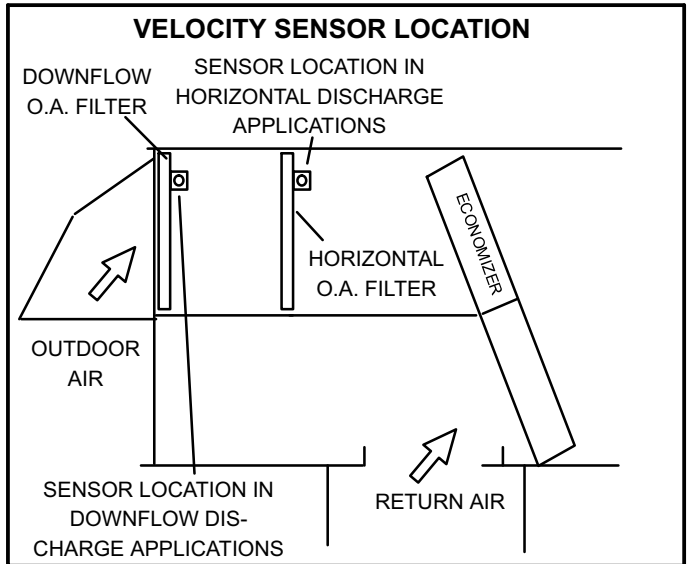

FIGURE 45

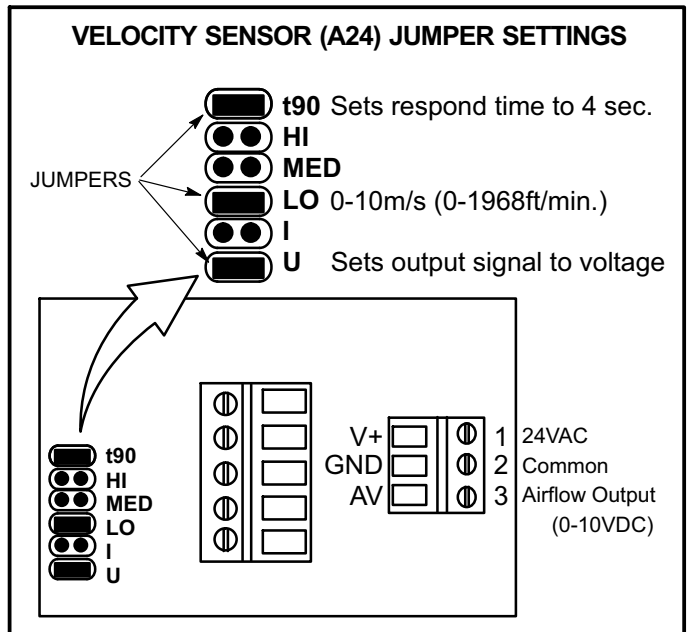

FIGURE 46

Q-Factory Installed Hot Gas Bypass (HGB)

Hot gas bypass is a factory-installed option only. The HGB valve routes refrigerant from the discharge line to the suction line to keep the evaporator coil from icing when supply air volume is low. The HGB valve will start to open when the suction pressure drops below 105 psig (R410A). The de-superheating TXV routes cooler gas from the liquid line to the suction line. This prevents high refrigerant temperatures in the compressor. See figure 47 for components and figure 48 for refrigerant routing.

HOT GAS BYPASS (HGB) PIPING - REFRIGERANT CIRCUIT 1 ONLY

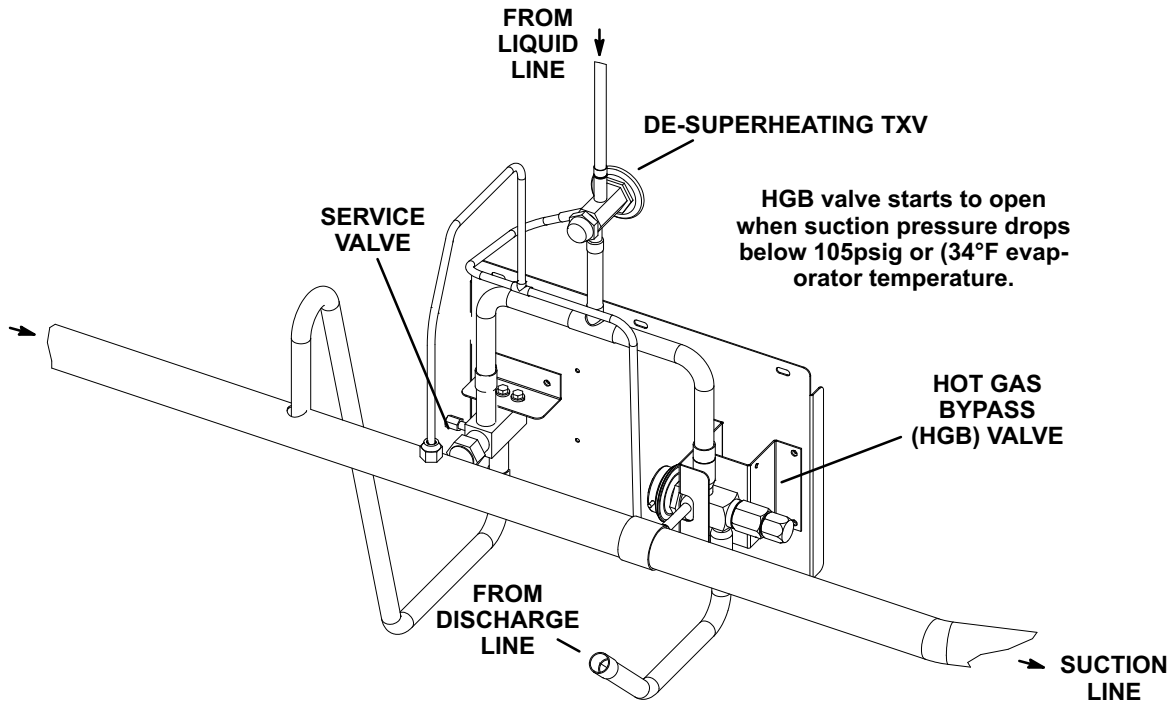

FIGURE 47

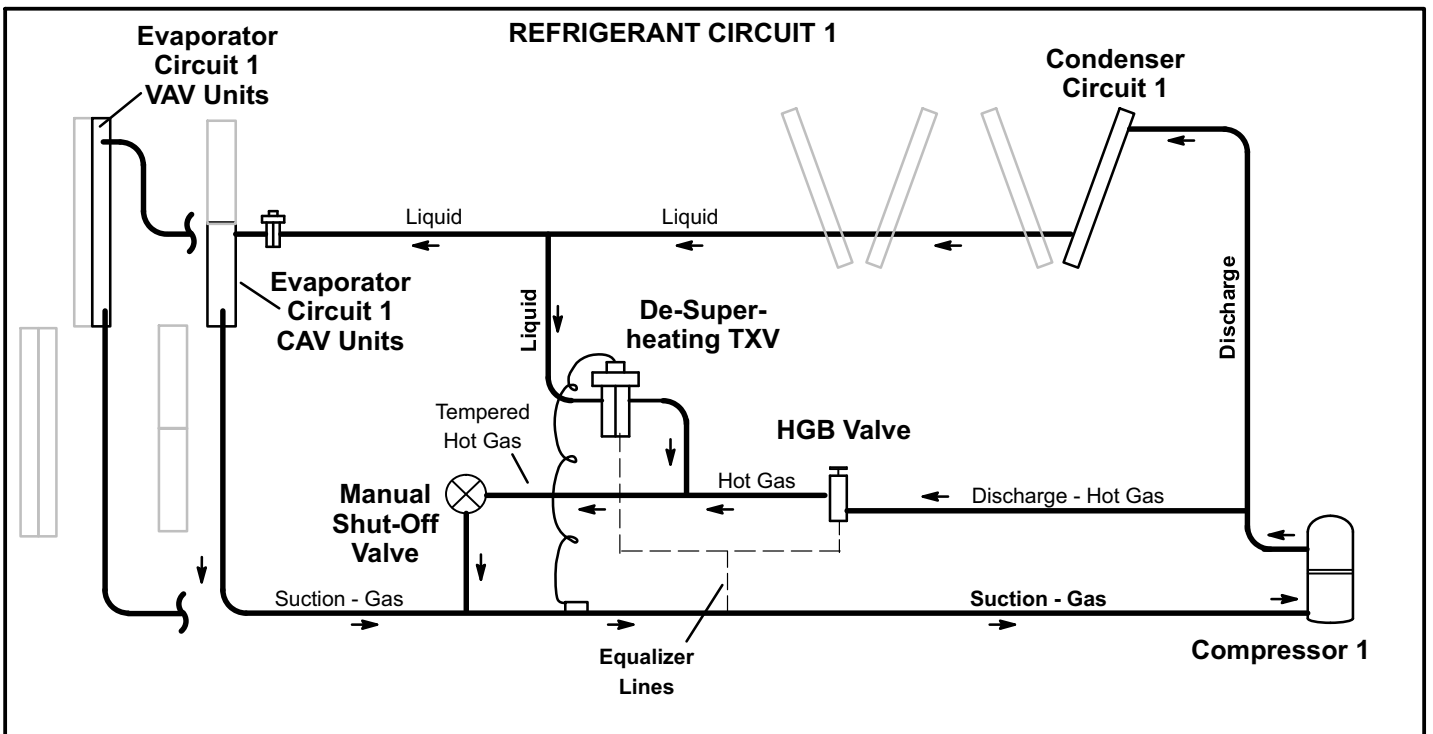
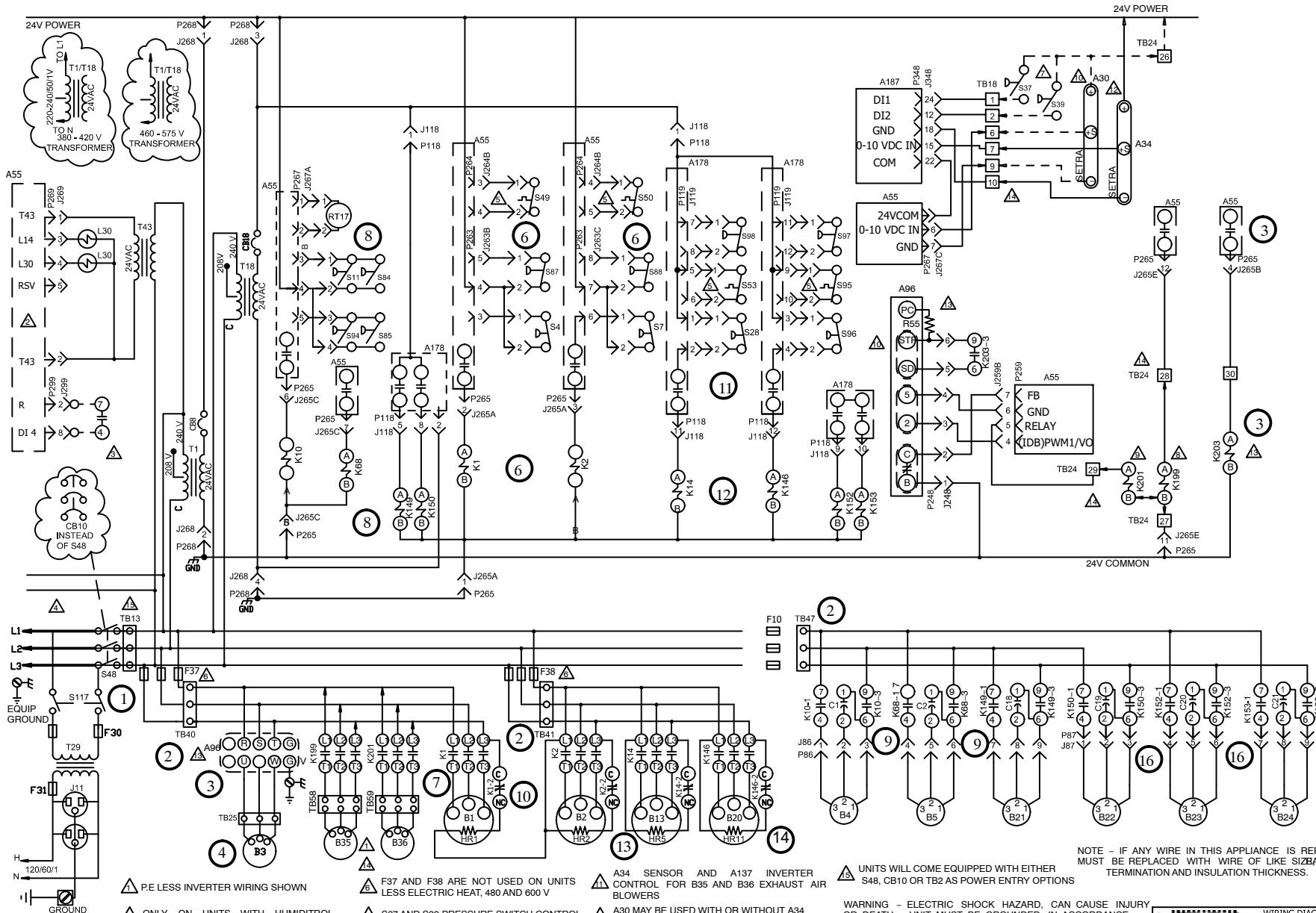

FIGURE 48



- ⚠ P.E LESS INVERTER WIRING SHOWN
- ⚠ ONLY ON UNITS WITH HUMIDITROL OPTION
- ⚠ EXTERNAL HUMIDITROL CONTACTS
- ⚠ CONNECTS TO SECTION "A" HEATING DIAGRAM, MAY BE LOCATED IN HEATING COMPARTMENT
- ⚠ S49,S50,S53 AND S95 ARE PART OF 5VDC CIRCUIT
- ⚠ F37 AND F38 ARE NOT USED ON UNITS LESS ELECTRIC HEAT, 480 AND 600 V
- ⚠ S37 AND S39 PRESSURE SWITCH CONTROL FOR POWER EXHAUST
- ⚠ VOLTAGE CONTROL SINGLE STAGE P.E
- ⚠ VOLTAGE CONTROL TWO STAGE P.E
- ⚠ A30 SENSOR FOR B3 SUPPLY AIR BLOWER IN VAV APPLICATIONS ONLY
- ⚠ A34 SENSOR AND A137 INVERTER CONTROL FOR B35 AND B36 EXHAUST AIR BLOWERS
- ⚠ A30 MAY BE USED WITH OR WITHOUT A34 A34 MAY BE USED WITH OR WITHOUT A30
- ⚠ FOR UNITS WITH BYPASS OPTION, PLEASE REFER TO SECTION 3B WIRING DIAGRAM
- ⚠ FOR POWER EXHAUST INVERTER REFER TO SECTION 5B WIRING DIAGRAM

UNITS WILL COME EQUIPPED WITH EITHER S48, CB10 OR TB2 AS POWER ENTRY OPTIONS

WARNING - ELECTRIC SHOCK HAZARD, CAN CAUSE INJURY OR DEATH. UNIT MUST BE GROUNDED IN ACCORDANCE WITH NATIONAL AND LOCAL CODES. DISCONNECT ALL POWER BEFORE SERVICING.

— DENOTES OPTIONAL COMPONENTS
 — LINE VOLTAGE FIELD INSTALLED
 - - - CLASS II FIELD WIRING

120 VAC FIELD PROVIDED POWER SUPPLY IS REQUIRED

NOTE: USE COPPER CONDUCTORS ONLY

NOTE - IF ANY WIRE IN THIS APPLIANCE IS REPLACED IT MUST BE REPLACED WITH WIRE OF LIKE SIZING, TERMINATION AND INSULATION THICKNESS.

08/17	WIRING DIAGRAM	08/17
537884-01		
COOLING - VFD		
LCH/LGH, 420S, 480S, 540S 1-G, J, Y		
SECTION B		REV. 0
Supersedes	New Form No. 537884-01	

537844-01 KEY

KEY	DESCRIPTION	KEY	DESCRIPTION
A30	SENSOR, DUCT STATIC PRESSURE	L30	VALVE, SOLENOID REHEAT COIL 2
A34	SENSOR, DIFFERENTIAL PRESSURE	R55	RESISTOR, VFD LOADING, A96
A55	CONTROL BOARD, MAIN	RT17	SENSOR, OUTDOOR AIR
A96	CONTROL, INVERTER SUPPLY	S4	SWITCH, LIMIT HI PRESS COMPRESS 1
A178	PANEL, COMP 3 & 4, C3 SECOND STAGE HEAT	S7	SWITCH, LIMIT HI PRESS COMPRESS 2
A187	CONTROL, GENERAL PURPOSE GP3	S11	SWITCH, LOW PRESS, LOW AMBIENT KIT COMP 1
B1	COMPRESSOR 1	S28	SWITCH, LIMIT HI PRESS COMPRESS 3
B2	COMPRESSOR 2	S37	SWITCH, PRESSURE EXHAUST FAN
B3	MOTOR, BLOWER	S39	SWITCH, PRESSURE EXHAUST FAN
B4	MOTOR, OUTDOOR FAN 1	S48	SWITCH, DISCONNECT
B5	MOTOR, OUTDOOR FAN 2	S49	SWITCH, FREEZE STAT COMPRESS 1
B13	COMPRESSOR 3	S50	SWITCH, FREEZE STAT COMPRESS 2
B20	COMPRESSOR 4	S53	SWITCH, FREEZE STAT COMPRESS 3
B21	MOTOR, OUTDOOR FAN 3	S84	SWITCH, LOW PRESS, LOW AMBIENT KIT COMP 2
B22	MOTOR, OUTDOOR FAN 4	S85	SWITCH, LOW PRESS, LOW AMBIENT KIT COMP 3
B23	MOTOR, OUTDOOR FAN 5	S87	SWITCH, LOW PRESS, COMP 1
B24	MOTOR, OUTDOOR FAN 6	S88	SWITCH, LOW PRESS, COMP 2
B35	MOTOR, EXHAUST BLOWER 1	S94	SWITCH, LOW PRESS, LOW AMBIENT KIT COMP 4
B36	MOTOR, EXHAUST BLOWER 2	S95	SWITCH, FREEZE STAT COMPRESS 4
C1	CAPACITOR, OUTDOOR FAN 1	S96	SWITCH, LIMIT HI PRESS COMPRESS 4
C2	CAPACITOR, OUTDOOR FAN 2	S97	SWITCH, LOW PRESS, COMP 4
C18	CAPACITOR, OUTDOOR FAN 3	S98	SWITCH, LOW PRESS, COMP 3
C19	CAPACITOR, OUTDOOR FAN 4	S117	SWITCH, GFI
C20	CAPACITOR, OUTDOOR FAN 5	T1	TRANSFORMER, CONTROL
C21	CAPACITOR, OUTDOOR FAN 6	T18	TRANSFORMER, CONTACTOR
CB8	CIRCUIT BREAKER T1	T29	TRANSFORMER, GFI
CB10	CIRCUIT BREAKER, MAIN DISCONNECT UNIT	TB2	TERMINAL BLOCK, POWER DISTRIBUTION
CB18	CIRCUIT BREAKER T18	TB13	TERMINAL BLOCK, POWER DISTRIBUTION
F10	FUSE, OUTDOOR FAN MOTOR	TB18	TERMINAL STRIP, CYCLE CONTROL
F30	FUSE, TRANSFORMER T29 PRIMARY	TB24	TERMINAL STRIP, UNIT ADDER
F31	FUSE, TRANSFORMER T29 SECONDARY	TB25	TERMINAL BLOCK, BLOWER
F37	FUSE, COMPRESSOR GROUP 1	TB40	TERMINAL BLOCK, COMPRESSOR 1
F38	FUSE, COMPRESSOR GROUP 2	TB41	TERMINAL BLOCK, COMPRESSOR 2, 3 & 4
HR1	HEATER COMPRESSOR 1	TB47	TERMINAL STRIP, OUTDOOR FANS
HR2	HEATER COMPRESSOR 2	TB58	TERMINAL BLOCK, POWER EXHAUST
HR5	HEATER COMPRESSOR 3	TB59	TERMINAL BLOCK, POWER EXHAUST
HR11	HEATER COMPRESSOR 4	J/P	JACK / PLUG DESCRIPTION
K1	CONTACTOR, COMPRESSOR 1	11	GFI, RECEPTACLE
K2	CONTACTOR, COMPRESSOR 2	86	OUTDOOR FAN INTERFACE
K10	RELAY, OUTDOOR FAN 1	87	OUTDOOR FAN INTERFACE 2
K14	CONTACTOR, COMPRESSOR 3	118	COMPRESSOR 3 AND 4, CONTROL
K68	RELAY, OUTDOOR FAN 2	119	COMPRESSOR 3 AND 4, INPUT
K146	CONTACTOR, COMPRESSOR 4	248	VFD CONTROL
K149	RELAY, OUTDOOR FAN 3	259	BLOWER ECM MOTOR
K150	RELAY, OUTDOOR FAN 4	263	HIGH AND LOW PRESSURE SWITCHES
K152	RELAY, OUTDOOR FAN 5	264	BLOWER DECK
K153	RELAY, OUTDOOR FAN 6	265	CONTACTORS AND RELAYS
K199	CONTACTOR, EXHAUST STG 1	267	OUTDOOR FAN AREA
K201	CONTACTOR, EXHAUST STG 2	268	TRANSFORMER 1 POWER
K203	RELAY, INVERTER CONTROL	269	HUMIDITROL
L14	VALVE, SOLENOID REHEAT COIL 1	299	HUMIDITROL INTERFACE
		348	CONTROL, GENERAL PURPOSE GP3

08/17	WIRING DIAGRAM 537884-01	08/17
COOLING - VFD		
LCH/LGH, 420S, 480S, 540S 1-G, J, Y		
SECTION B		REV. 0
Supersedes	New Form No. 537884-01	

SEQUENCE OF OPERATION - M3 UNIT CONTROLLER

Power:

- 1- Line voltage from TB2, unit disconnect S48, or other factory or field installed optional power disconnects, such as CB10, energizes transformer T1 and T18. Transformer T1 provides 24VAC power to A55 Unit Controller and T18 provides 24VAC power to A178 Compressor 3 & 4 Controller. The two Controllers provide 24VAC power to the unit cooling, heating and blower controls and thermostat.
- 2- Terminal strip TB40, TB41 and TB47 are also energized when the unit disconnect closes. These terminal strips supply line voltage to compressor crankcase heaters, compressors, blower motors and fan motors.

Blower Operation (OCP input must be on):

- 3- The main control module A55 receives a demand from thermostat terminal G. A55 energizes inverter relay K203 with 24VAC.
- 4- N.O. K203-3 closes, energizing inverter A96 energizing blower B3.

1st Stage Cooling

- 5- First stage cooling demand energizes Y1 and G in the thermostat. G energizes blower, if blower is not already running (see step 3).
- 6- 24VAC is routed to the A55 Unit Controller. After A55 proves N.C. low pressure switches S87 and S88, N.C. freezestats S49 and S50 and N.C. high pressure switches S4 and S7, compressor contactors K1 and K2 are energized.
- 7- N.O. contacts K1-1 and K2-1 close energizing compressor B1 and B2.
- 8- A55 Unit Controller and A178 Compressor 3 and 4 Controller energize fan contactors K10, K68 and K149 based on low ambient switch S11 and S84 inputs and pre-defined control logic.
- 9- N.O. contacts K10-1, K68-1 and K149-1 close energizing condenser fan B4, B5 and B21.
- 10- N.C. auxiliary switches on K1 and K2 compressor contactors open de-energizing crankcase heater HR1 and HR2.

2nd Stage Cooling

- 11- Second stage cooling demand energizes Y2.
- 12- 24VAC is routed to A178 Compressor 3 and 4 Controller. After A178 proves N.C. low pressure switches S98 and S97, N.C. freezestats S53 and S95 and N.C. high pressure switches S28 and S96, compressor contactors K14 and K146 are energized.
- 13- N.O. contacts K14-1 close energizing compressor B13.
- 14- N.O. contacts K146-1 close energizing compressor B20.
- 15- A178 Compressor 3 and 4 Controller energizes fan contactors K150, K152 and K153 based on low ambient switch S85 and S94 inputs and pre-defined Unit Controller logic.
- 16- N.O. contacts K150-1, K152-1 and K153-1 close energizing condenser fans B22, B23 and B24.
- 17- N.C. auxiliary switches on K14 and K146 compressor contactors open de-energizing crankcase heater HR5 and HR11.

GAS HEAT

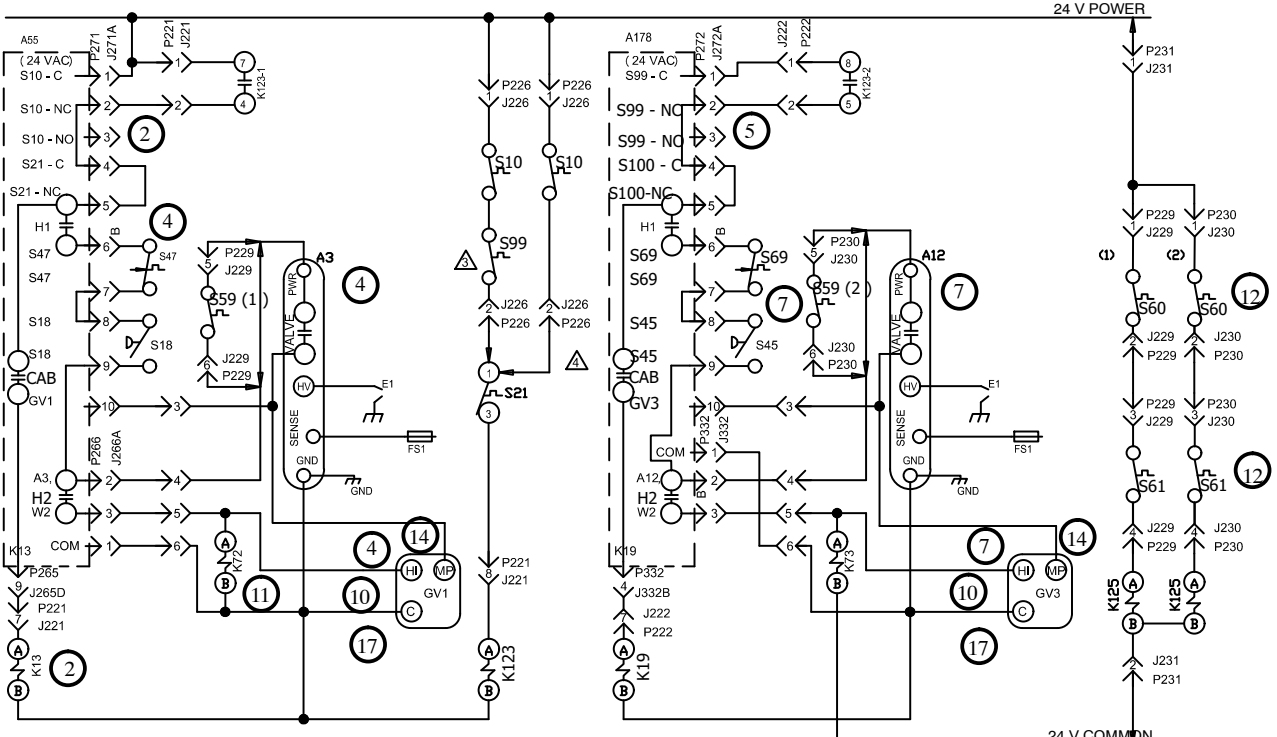

- ▲ CSA (-50C) LOW AMBIENT KIT (OPTIONAL)
- ▲ T3 AND T13 USED ON 575 V UNITS ONLY
- ▲ S99 IS USED ON DOWN DISCHARGE APPLICATIONS
- ▲ HORIZONTAL DISCHARGE APPLICATIONS
- ▲ J224, P224 USED ON 208 / 240 V UNITS

KEY	DESCRIPTION
A3	CONTROL, BURNER 1
A12	CONTROL, BURNER 2
A55	CONTROL BOARD, MAIN
A178	CONTROL BOARD, COMP 3 & 4, 2ND STAGE HEAT
B6	MOTOR COMBUSTION AIR BLOWER 1
B15	MOTOR COMBUSTION AIR BLOWER 2
C3	CAPACITOR, COMB AIR BLOWER 1
C11	CAPACITOR, COMB AIR BLOWER 2
E1	SPARK
FS1	SENSOR, FLAME
GV1	VALVE, GAS 1
GV3	VALVE, GAS 2
HR6	HEATER, -50C LOW AMBIENT KIT
K13, -1	RELAY, COMBUSTION AIR BLOWER 1
K19, -1	RELAY, COMBUSTION AIR BLOWER 2
K72, -1	RELAY, GAS 3
K73, -1	RELAY, GAS 4
K123, -1	RELAY, PRIMARY LIMIT
K125, -1	RELAY, HEAT SHUT OFF
S10	SWITCH, LIMIT PRIMARY GAS
S18	SWITCH, COMB AIR BLOWER 1 PROOF
S21	SWITCH, LIMIT SECONDARY GAS HEAT
S45	SWITCH, COMB AIR BLOWER 2 PROOF
S47	SWITCH, FLAME ROLL OUT BURNER
S59	TSTAT, OPEN -20F, CLOSE 10F
S60	TSTAT, OPEN 20F, CLOSE -10F
S61	TSTAT, OPEN 50F, CLOSE 20F
S69	SWITCH, FLAME ROLL OUT 2
S99	SWITCH, LIMIT PRIMARY BURNER 2
T3	TRANSFORMER, COMB AIR BLOWER 1
T13	TRANSFORMER, COMB AIR BLOWER 2
TB47	TERMINAL STRIP, EXHAUST FANS

J/P	JACK/PLUG DESCRIPTION
1	COMBUSTION AIR BLOWER 1
13	COMBUSTION AIR BLOWER 2
221	HARNESSE BURNER 1
222	HARNESSE BURNER 2
224	CAB POWER 208/240V
225	CAB POWER 480/600V
226	S10 HORIZONTAL DISCHARGE LIMIT
228	VESTIBULE HEATER
229	VESTIBULE HEATER CONTROL 1
230	VESTIBULE HEATER CONTROL 2
231	VESTIBULE HEATER CONTROL PWR
265	CONTACTOR RELAY
266	HEATING CONTROL STG 1
271	HEATING SENSORS STG 1
272	HEATING SENSORS STG 2
332	HEATING CONTROL STG 2

08/17 WIRING DIAGRAM 08/17

537218-03

HEATING

GAS HEAT
ENERGENGE 500 AND 800 UNITS

SECTION A

Supersedes New Form No.
537218-03

SEQUENCE OF OPERATION GAS HEAT

FIRST STAGE HEAT:

- 1 - Heating demand initiates at W1 in thermostat.
- 2 - 24VAC is routed to the A55 Unit Controller. After A55 proves N.C. primary limit S10, the combustion air blower relay K13 is energized.
- 3 - N.O. K13-1 contacts close allowing line voltage (or transformer T3 in 460V and 575V only) to energize combustion air blower B6.
- 4 - After the combustion air inducer B6 has reached full speed, the combustion air proving switch (S18) contacts close. The A55 routes 24VAC through N.C. burner 1 flame rollout switch S47 and the closed contacts of the combustion air proving switch (S18) to energize the ignition module A3. After a 30 second delay A3 energizes the W1 terminal (low fire) of gas valve GV1.
- 5 - After A178 proves N.C. primary gas heat limit S99 the combustion air inducer relay K19 is energized.
- 6 - N.O. K19-1 contacts close allowing line voltage (or transformer T13 in 460V and 575V only) to energize combustion air inducer B15.
- 7 - After the combustion air inducer B15 has reached full speed, the combustion air proving switch (S45) contacts close. The A178 routes 24VAC through N.C. burner 2 flame rollout switch S69 and the closed contacts of the combustion air proving switch (S45) to energize the ignition module A12. After a 30 second delay A12 energizes the W1 terminal (low fire) of gas valve GV3. Indoor blower energizes after time delay Time delay is field adjustable with a factory set default of 40 seconds.

SECOND STAGE HEAT:

- 8 - With first stage heat operating, an additional heating demand initiates W2 in the thermostat.
- 9 - A second stage heating demand is received by A55 Unit Controller.
- 10 - A55 and A178 will energize the corresponding W2 terminal (high fire) of gas valves GV1 and GV3 respectively.
- 11 - N.O. terminals 5 and 7 on relays K72 and K73 close, energizing combustion air inducers B6 and B15 on second stage heat (high speed).

OPTIONAL LOW AMBIENT KIT (C.G.A. -50° C LOW AMBIENT KIT):

- 12 - Line voltage is routed through N.O. contacts on relays K125 (1) and K125 (2) to energize low ambient kit heater HR6. N.C. low ambient kit thermostats S60 and S61 open to de-energize HR6.

END OF SECOND STAGE HEAT:

- 13 - Heating demand is satisfied. Terminal W2 is de-energized.
- 14 - Terminals W2 (high fire) of GV1 and GV3 are de-energized by the A55 and A178.
- 15 - Terminals 5 and 7 on K72 and K73 open. Combustion air inducers B6 and B15 ramp down to first stage heat (low speed).

END OF FIRST STAGE HEAT:

- 16 - Heating demand is satisfied. Terminal W1 is de-energized.
- 17 - Ignition module A3 is de-energized by A55 in turn de-energizing terminal W1 of GV1. Combustion inducer relay K13 is also de-energized. At the same instant, ignition module A12 is de-energized by A55 module in turn de-energizing the W1 terminal of GV3. K19 combustion air inducer relay is also de-energized.

ELECTRONIC OR ELECTROMECHANICAL THERMOSTAT

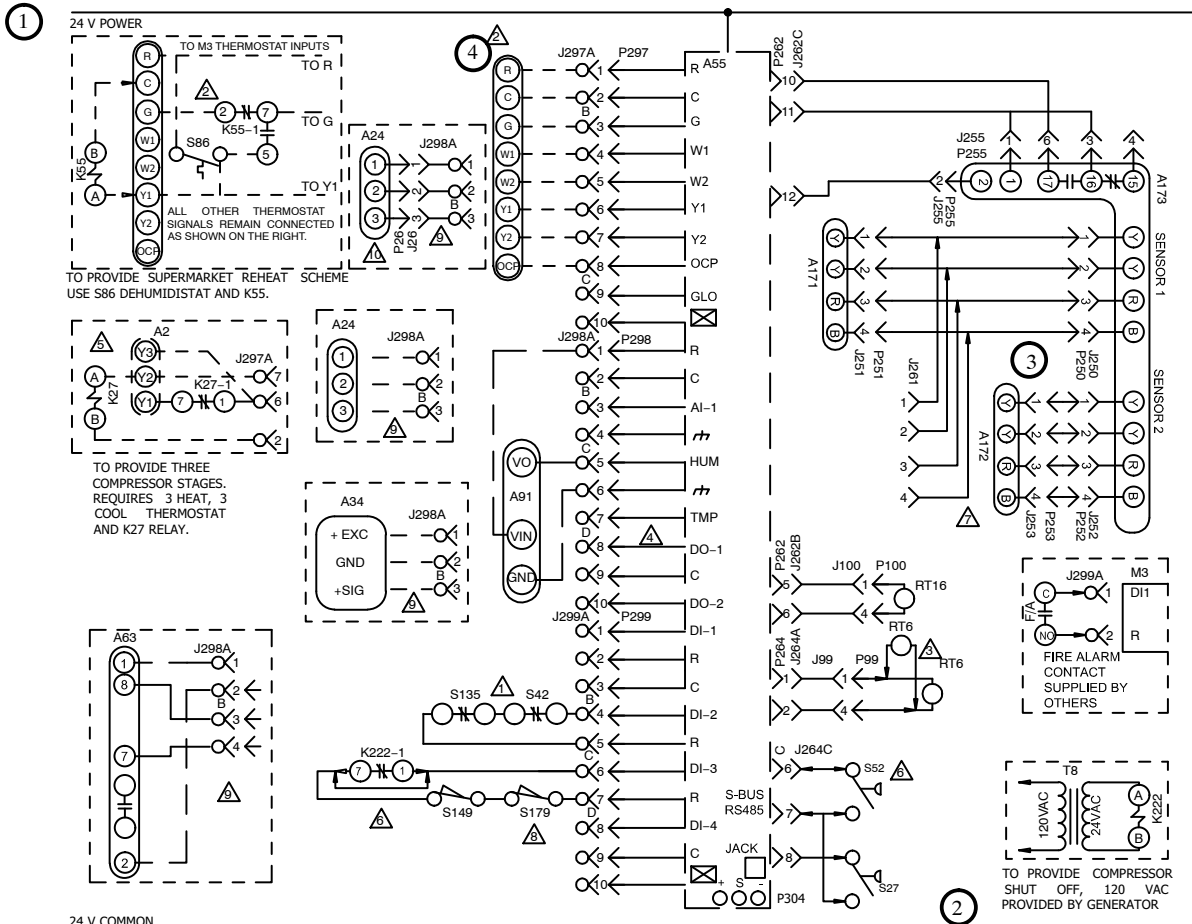

KEY	DESCRIPTION
	COMPONENT
A2	SENSOR, ELECTRONIC THERMOSTAT
A24	CONTROL, OUTDOOR AIR CFM FLOW
A34	DIFFERENTIAL PRESSURE TRANSDUCER
A55	CONTROL BOARD, MAIN
A83	SENSOR, CO2 (IAQ) OPTIONAL
A91	SENSOR, HUMIDITY
A171	SENSOR ONE, SMOKE, RETURN AIR
A172	SENSOR TWO, SMOKE, SUPPLY AIR
A173	MODULE, CONTROL SMOKE DETECTION
J26	JACK, AIR FLOW CONTROL
J99	JACK, RT16 RETURN AIR SENSOR
J100	JACK, RT6 SUPPLY AIR SENSOR
J250	JACK, SMOKE DETECTOR ONE
J251	JACK, SMOKE DETECTOR ONE
J252	JACK, SMOKE DETECTOR TWO
J253	JACK, SMOKE DETECTOR TWO
J255	JACK, MODULE, CONTROL SMOKE DETECTION
J261	JACK, SUPPLY SMOKE DETECTOR JUMPER
J262	JACK, ECONOMIZER
J264	JACK, BLOWER DECK
J297	JACK, THERMOSTAT - DDC INTERFACE
J298	JACK, IAQ INTERFACE
J299	JACK, SAFETY INTERFACE
K27, -1	RELAY, TRANSFER
K55, -1	RELAY, BLOWER
K222, -1	RELAY, COMPRESSOR LOCKOUT
P26	PLUG, AIR FLOW CONTROL
P99	PLUG, RT16 RETURN AIR SENSOR
P100	PLUG, RT6 SUPPLY AIR SENSOR
P250	PLUG, SMOKE DETECTOR ONE
P251	PLUG, SMOKE DETECTOR ONE
P252	PLUG, SMOKE DETECTOR TWO

P253	PLUG, SMOKE DETECTOR TWO
P255	PLUG, MODULE, CONTROL SMOKE DETECTION
P262	PLUG, ECONOMIZER
P264	PLUG, BLOWER DECK
P297	PLUG, THERMOSTAT - DDC INTERFACE
P298	PLUG, IAQ INTERFACE
P299	PLUG, SAFETY INTERFACE
P304	PLUG, SYS BUS
RT6	SENSOR, SUPPLY AIR TEMP
RT16	SENSOR, RETURN AIR TEMP
S27	SWITCH, FILTER
S52	SWITCH, AIRFLOW
S42	SWITCH, OVERLOAD RELAY BLOWER MOTOR
S86	SWITCH, DEHUMIDISTAT
S135	OVERLOAD, BLOWER MOTOR SUPPLY
S149	SWITCH, OVERFLOW ONE
S179	SWITCH, OVERFLOW TWO
T8	TRANSFORMER, 120 V GENERATOR POWERED

- DESIGNATES OPTIONAL WIRING
- CLASS II FIELD WIRING
- ⚠ FOR MOTORS WITH S42 EXTERNAL OVERLOAD LESS INVERTER, SEE INVERTER WITH BY PASS FOR S42 HOOK UP
- ⚠ USE S86 DEHUMIDISTAT AND K55 FOR OPTIONAL SUPERMARKET REHEAT SCHEME, PRODIGY PARAMETERS NEED TO BE MODIFIED UNDER THE SETTINGS MENU OR VIA UC SOFTWARE FOR SIMULTANEOUS HEATING AND COOLING.
- ⚠ REMOTE LOCATION OF RT6
- ⚠ P298-8 (DO-1) IS SERVICE RELAY OUTPUT (24VAC) IF USED CONNECT TO AN INDICATOR LIGHT
- ⚠ THERMOSTAT HOOKUP FOR PROGRAMMABLE CONFIGURATION OF THE BOARD (A55).
- ⚠ PRODIGY SETTINGS MUST BE MODIFIED WHEN K222, S42, S52, S149 OR S179 ARE INSTALLED
- ⚠ CONNECT A172 SENSOR TO J261 ON SUPPLY AIR SMOKE DETECTOR ONLY
- ⚠ S179, OVERFLOW SWITCH USED ON LGH/LCH 420-600 UNITS ONLY
- ⚠ A63, A34 & A24 ARE MUTUALLY EXCLUSIVE
- ⚠ FACTORY INSTALLED OPTION FOR LGH/LCH 242-600 UNITS ONLY

SEQUENCE OF OPERATION

- 1 - Terminal block P297 on the A55 Unit Controller energizes the thermostat components with 24VAC.
- 2 - The A55 Unit Controller proves the optional N.O. filter switch S27(indicates dirty filter when closed) and optional N.O. air flow switch S52(indicates no air [i.e. broken belt] system shuts down).
- 3 - The A55 Unit Controller receives data from the supply and return smoke detectors A171 and A172, blower motor overload relay S42, discharge sensor RT6, return air sensor RT16 and the outdoor air sensor RT17.
- 4 - The A55 Unit Controller receives data from the electronic thermostat A2 (Y1, Y2, W1, W2, G, OCP) and the CO2 sensor (if economizer is used) via terminal block P297. A55 energizes the appropriate components.

08/17	WIRING DIAGRAM	08/17
537108-03		
ACCESSORIES		
ELECTRONIC OR ELECTROMECHANICAL THERMOSTAT FOR EMERGENCE		
SECTION C		REV. 3
Supersedes	New Form No. 537108-03	

EHA-30kW, 45kW, 60kW, 75kW, 90kW Y Voltage

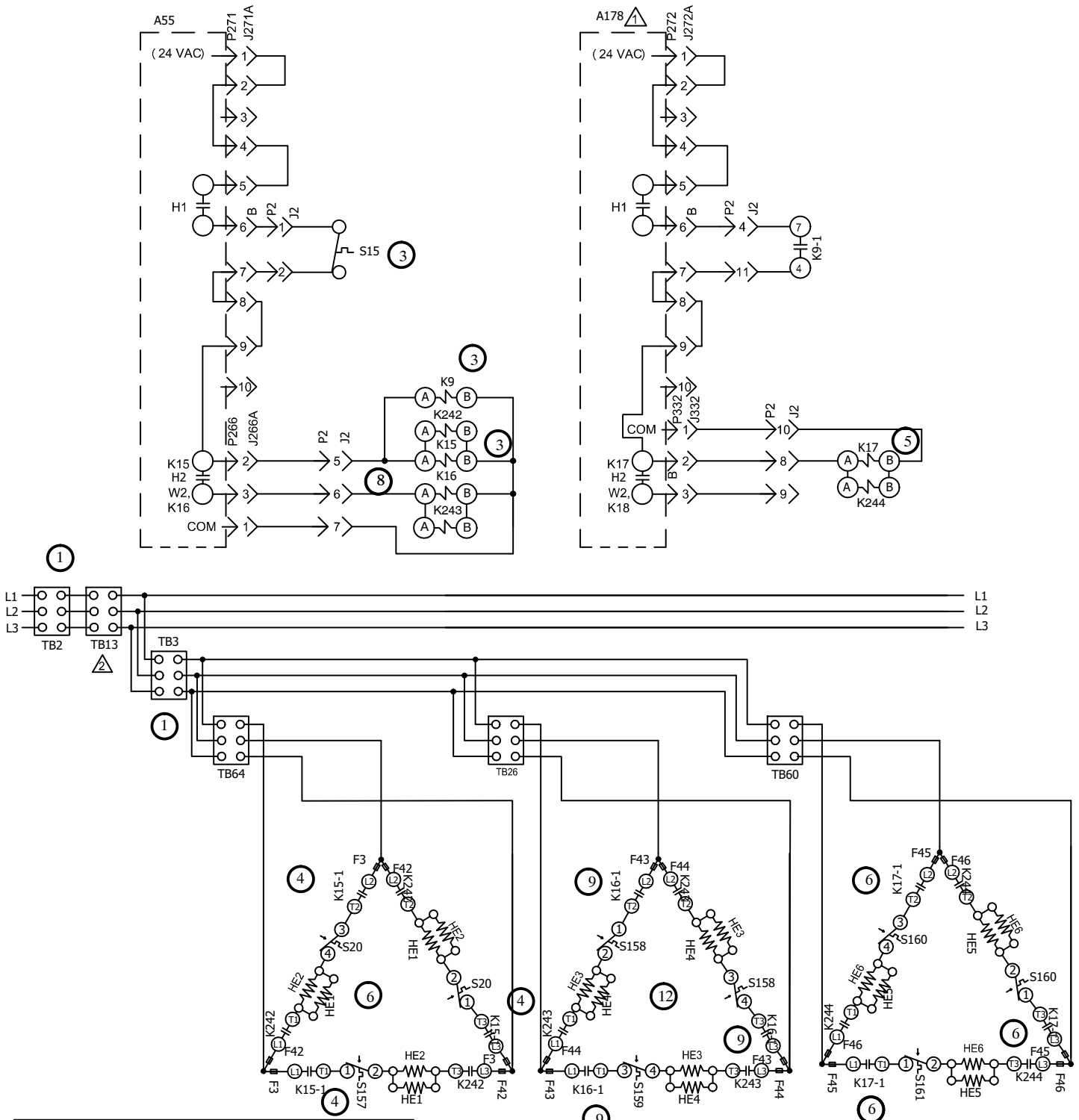

01/17		WIRING DIAGRAM	01/17
		ENERGENCE	
537221-03		ELECTRIC HEATING	
EHA, 30, 45, 60, 75, 90 - 1, 2, - Y			
SECTION A		REV 0	
Supersedes	New Form No. 537221-03		

- NOT USED ON 30 - 60KW UNITS
- TB13 IS USED IN SOME UNITS
- DENOTES OPTIONAL COMPONENTS

537221-03 KEY

J/P	JACK/PLUG DESCRIPTION
2	ELECTRIC HEAT
266	HEATING CONTROL STG 1
271	HEATING SENSORS STG 1
272	HEATING SENSORS STG 2
332	HEATING CONTROL STG 2

DESIGNATION	VOLTAGE
Y	208-230/60/3

KW	HE1	HE2	HE3	HE4	HE5	HE6
30	15	15				
45	15	15	15			
60	15	15	15	15		
75	15	15	15	15	15	
90	15	15	15	15	15	15

DESCRIPTION	
KEY	DESCRIPTION
A55	PANEL, MAIN BOARD LENNOX
A178	PANEL, COMP 3 & 4, 2ND STAGE HEAT - C3
F3	FUSE, ELECTRIC HEAT 1
F42	FUSE, ELECTRIC HEAT 2
F43	FUSE, ELECTRIC HEAT 3
F44	FUSE, ELECTRIC HEAT 4
F45	FUSE, ELECTRIC HEAT 5
F46	FUSE, ELECTRIC HEAT 6
HE1	ELEMENT, ELECTRIC HEAT 1
HE2	ELEMENT, ELECTRIC HEAT 2
HE3	ELEMENT, ELECTRIC HEAT 3
HE4	ELEMENT, ELECTRIC HEAT 4
HE5	ELEMENT, ELECTRIC HEAT 5
HE6	ELEMENT, ELECTRIC HEAT 6
K9, -1	RELAY, HEAT
K15,-1	CONTACTOR, ELECTRIC HEAT 1
K16,-1	CONTACTOR, ELECTRIC HEAT 2
K17,-1	CONTACTOR, ELECTRIC HEAT 3
K242	CONTACTOR, ELECTRIC HEAT 1
K243	CONTACTOR, ELECTRIC HEAT 2
K244	CONTACTOR, ELECTRIC HEAT 3
S15	SWITCH, LIMIT PRIMARY ELECTRIC HEAT
S20	SWITCH, LIMIT SECONDARY ELECTRIC HEAT 1
S157	SWITCH, LIMIT SECONDARY ELECTRIC HEAT 2
S158	SWITCH, LIMIT SECONDARY ELECTRIC HEAT 3
S159	SWITCH, LIMIT SECONDARY ELECTRIC HEAT 4
S160	SWITCH, LIMIT SECONDARY ELECTRIC HEAT 5
S161	SWITCH, LIMIT SECONDARY ELECTRIC HEAT 6
TB2	TERMINAL BLOCK, UNIT POWER DISTRIBUTION
TB3	TERMINAL BLOCK, ELECTRIC HEAT CIRCUIT
TB13	TERMINAL BLOCK, POWER DISTRIBUTION
TB26	TERMINAL STRIP, ELECTRIC HEAT CIRCUIT 2
TB60	TERMINAL STRIP, ELECTRIC HEAT CIRCUIT 3
TB64	TERMINAL STRIP, ELECTRIC HEAT CIRCUIT 1

01/17		WIRING DIAGRAM ENERGENCE 537221-03	01/17
	ELECTRIC HEATING		
EHA, 30, 45, 60, 75, 90 - 1, 2, - Y			
SECTION A			REV 0
Supersedes		New Form No. 537221-03	

EHA-30Kw / 180Kw G & J Voltage

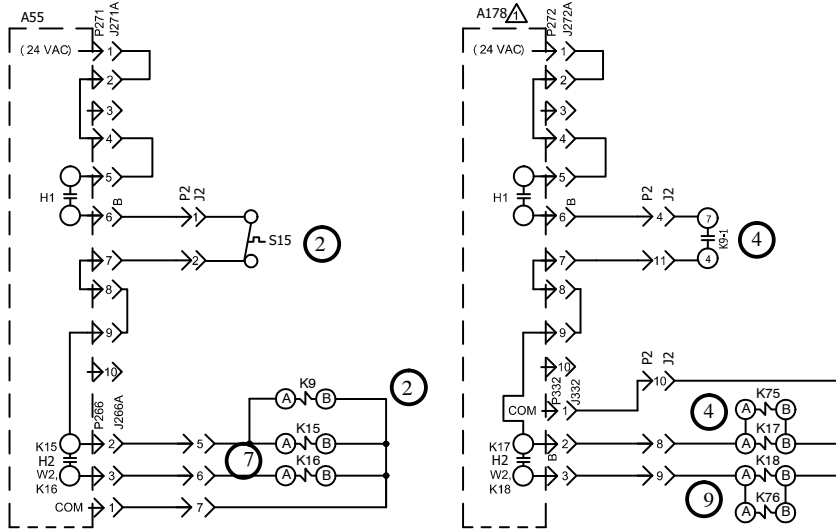

▲ NOT USED ON 30 - 60KW UNITS
 ▲ TB13 IS USED IN SOME UNITS

KW	HE1	HE2	HE3	HE4	HE5	HE6	HE7	HE8	HE9	HE10	HE11	HE12
30	15	15										
45	15	15	15									
60	15	15	15	15								
75	15	15	15	15	15							
90	15	15	15	15	15	15						
105	15	15	15	15	15	15	15					
120	15	15	15	15	15	15	15	15				
135	15	15	15	15	15	15	15	15	15			
150	15	15	15	15	15	15	15	15	15	15		
165	15	15	15	15	15	15	15	15	15	15	15	
180	15	15	15	15	15	15	15	15	15	15	15	15

← DENOTES OPTIONAL COMPONENT

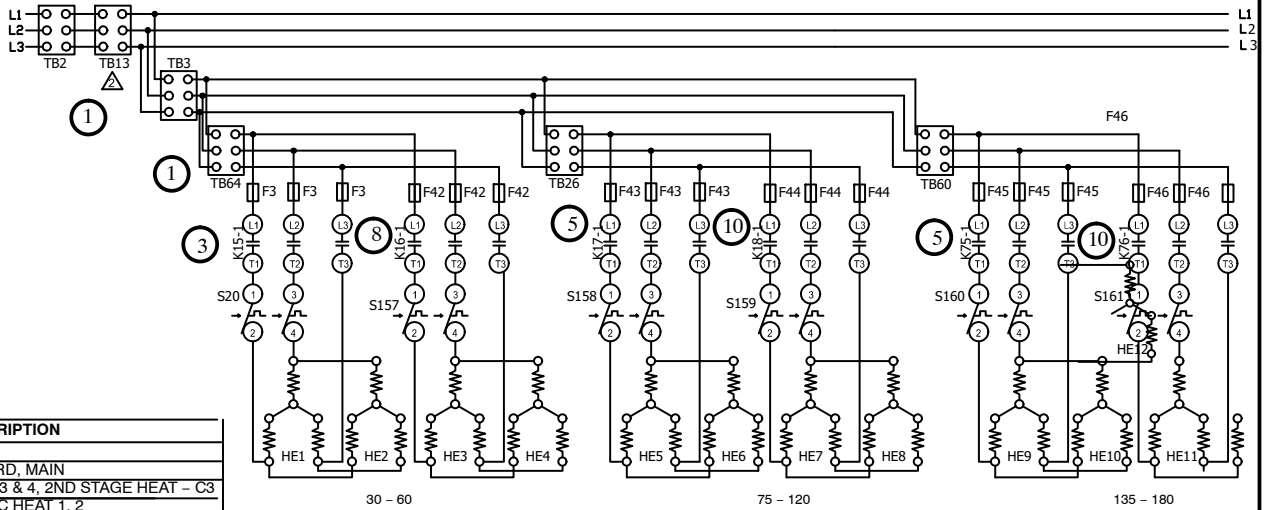

DESCRIPTION	
KEY	DESCRIPTION
A55	CONTROL BOARD, MAIN
A178	BOARD, COMP 3 & 4, 2ND STAGE HEAT - C3
F3	FUSE, ELECTRIC HEAT 1, 2
F42	FUSE, ELECTRIC HEAT 3, 4
F43	FUSE, ELECTRIC HEAT 5, 6
F44	FUSE, ELECTRIC HEAT 7, 8
F45	FUSE, ELECTRIC HEAT 9, 10
F46	FUSE, ELECTRIC HEAT 11, 12
HE1	ELEMENT, ELECTRIC HEAT 1
HE2	ELEMENT, ELECTRIC HEAT 2
HE3	ELEMENT, ELECTRIC HEAT 3
HE4	ELEMENT, ELECTRIC HEAT 4
HE5	ELEMENT, ELECTRIC HEAT 5
HE6	ELEMENT, ELECTRIC HEAT 6
HE7	ELEMENT, ELECTRIC HEAT 7
HE8	ELEMENT, ELECTRIC HEAT 8
HE9	ELEMENT, ELECTRIC HEAT 9
HE10	ELEMENT, ELECTRIC HEAT 10
HE11	ELEMENT, ELECTRIC HEAT 11
HE12	ELEMENT, ELECTRIC HEAT 12
K9, -1	RELAY, HEAT
K15, -1	CONTACTOR, ELECTRIC HEAT 1
K16, -1	CONTACTOR, ELECTRIC HEAT 2
K17, -1	CONTACTOR, ELECTRIC HEAT 3
K18, -1	CONTACTOR, ELECTRIC HEAT 4
K75, -1	CONTACTOR, ELECTRIC HEAT 5
K76, -1	CONTACTOR, ELECTRIC HEAT 6

S15	SWITCH, LIMIT PRIMARY ELECTRIC HEAT
S20	SWITCH, LIMIT SECONDARY ELECTRIC HEAT 1
S157	SWITCH, LIMIT SECONDARY ELECTRIC HEAT 2
S158	SWITCH, LIMIT SECONDARY ELECTRIC HEAT 3
S159	SWITCH, LIMIT SECONDARY ELECTRIC HEAT 4
S160	SWITCH, LIMIT SECONDARY ELECTRIC HEAT 5
S161	SWITCH, LIMIT SECONDARY ELECTRIC HEAT 6
TB2	TERMINAL BLOCK, UNIT POWER DISTRIBUTION
TB3	TERMINAL BLOCK, ELECTRIC HEAT CIRCUIT
TB13	TERMINAL BLOCK, POWER DISTRIBUTION
TB26	TERMINAL BLOCK, ELECTRIC HEAT CIRCUIT 2
TB60	TERMINAL BLOCK, ELECTRIC HEAT CIRCUIT 3
TB64	TERMINAL BLOCK, ELECTRIC HEAT CIRCUIT 1

J/P	JACK/PLUG DESCRIPTION
2	ELECTRIC HEAT
266	HEATING CONTROL STG 1
271	HEATING SENSORS STG 1
272	HEATING SENSORS STG 2
332	HEATING CONTROL STG 2

DESIGNATION	VOLTAGE
G	460/60/3
J	575/60/3

01/17		WIRING DIAGRAM	01/17
		ENERGENCE	
		537220-02	
ELECTRIC HEATING			
E1EH - 30, 45, 60, 90, 105, 120, 135, 150, 165, 180 - I - G, J			
SECTION A			REV 0
Supersedes		New Form No.	
		537220-02	

SEQUENCE OF OPERATION

HEATING ELEMENTS:

- 1 - Terminal strip TB2 (CB10 or S48 may be in place of TB2) supplies line power to TB3. TB3 supplies line voltage to the heating element terminal strips. Each element is protected by a fuse and secondary limit.

FIRST STAGE HEAT:

- 2 - Heating demand initiates at W1 in thermostat.
- 3 - 24VAC is routed to the A55 Unit Controller. After A55 proves N.C. primary limit S15, the electric heat contactor K15 and heat relay K9 are energized. Indoor blower is energized with no time delay.
- 4 - N.O. contact K15-1 closes energizing heating elements HE1 and HE2.
- 5 - A178 is energized when N.O. contacts K9-1 close. A N.O. contact in A178 closes energizing electric heat relay K17.
- 6 - N.O. contacts K17-1 close energizing elements HE5 and HE6.

SECOND STAGE HEAT:

- 7 - With the first stage heat operating, an additional heating demand initiates at W2 in the thermostat.

FIRST STAGE HEAT:

- 1 - Heating demand initiates at W1 in thermostat.
- 2 - 24VAC is routed to the A55 Unit Controller. After A55 proves N.C. primary limit S15, the electric heat contactor K15 and heat relay K9 are energized. Indoor blower is energized with no time delay.
- 3 - N.O. contact K15-1 closes energizing heating elements HE1 and HE2.
- 4 - A55 is energized when N.O. contacts K9-1 close. N.O. contacts in A55 close energizing electric heat relays K17 and K75.
- 5 - N.O. contacts K17-1 and K75-1 close energizing elements HE5, HE6 and HE10.

SECOND STAGE HEAT:

- 6 - With the first stage heat operating, an additional heating demand initiates at W2 in the thermostat.
- 7 - 24VAC is routed through the A55 Unit Controller, which in turn energizes the electric heat contactor K16.

EHA Y VOLTAGE

- 8 - 24VAC is routed through the A55 Unit Controller, which in turn energizes the electric heat contactor K16.
- 9 - N.O. contacts K16-1 close energizing elements HE3 and HE4.

END OF SECOND STAGE HEAT:

- 10 - Heating demand is satisfied. Terminal W2 in the thermostat is de-energized.
- 11 - Electric heat contactors K16 is de-energized.
- 12 - Heating elements HE3 and HE4 are de-energized.

END OF FIRST STAGE HEAT:

- 13 - Heating demand is satisfied. Terminal W1 in the thermostat is de-energized.
- 14 - Electric heat contactors K15 and K17 are de-energized.
- 15 - Heating elements HE1, HE2, HE5 and HE6 are de-energized.

EHA G, J VOLTAGE

- 8 - N.O. contacts K16-1 close energizing elements HE3 and HE4.
- 9 - 24VAC is routed through A178 to energize electric heat contactor K18 and K76.
- 10 - N.O. Contacts K18-01 and K76-01 close, energizing elements HE7, HE8, HE11 and HE12.

END OF SECOND STAGE HEAT:

- 11 - Heating demand is satisfied. Terminal W2 in the thermostat is de-energized.
- 12 - Electric heat contactors K18 and K76 are de-energized.
- 13 - Heating elements HE3, HE7, HE8, HE11 and HE12 are de-energized.

END OF FIRST STAGE HEAT:

- 14 - Heating demand is satisfied. Terminal W1 in the thermostat is de-energized.
- 15 - Electric heat contactors K15, K17 and K75 are de-energized.
- 16 - Heating elements HE1, HE2, HE5, HE6, HE9 and HE10 are de-energized.