



**LGT**

**Enlight™ Rooftop Units  
High Efficiency - 60 Hz**

**COMMERCIAL  
PRODUCT SPECIFICATIONS**

Bulletin No. 210979

June 2024

Supersedes all previous versions

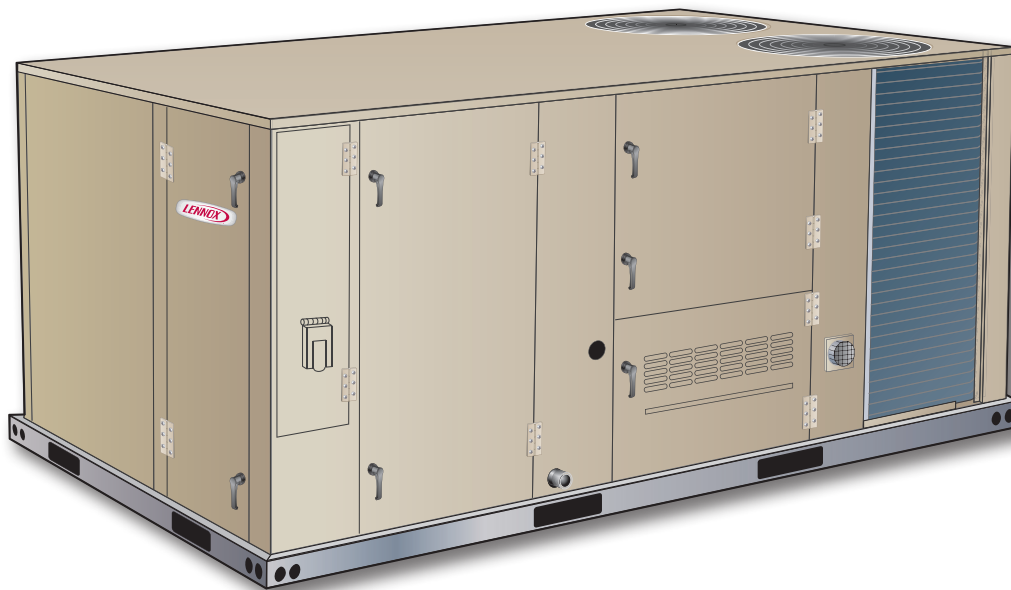

**ENLIGHT**



**CORE**  
CONTROL SYSTEM



**ASHRAE 90.1  
COMPLIANT**

**SMARTWIRE™ SYSTEM**

**7.5 to 12.5 Tons**

**Net Cooling Capacity - 90,000 to 136,000 Btuh**

**Gas Input Heat Capacity - 130,000 to 240,000 Btuh**

**MODEL NUMBER IDENTIFICATION**

**LGT120H4ES1Y**

**Brand/Family**  
L = Enlight™

**Unit Type**  
G = Packaged Gas Heat w/ Electric Cooling

**Major Design Sequence**  
T = 1st Generation

**Nominal Cooling Capacity - Tons**  
092 = 7.5 Tons  
102 = 8.5 Tons  
120 = 10 Tons  
150 = 12.5 Tons

**Cooling Efficiency**  
H = High Efficiency

**Voltage**  
Y = 208/230V-3 phase-60Hz  
G = 460V-3 phase-60Hz  
J = 575V-3 phase-60Hz

**Minor Design Sequence**  
1 = 1st Revision

**Heating Type**  
S = Standard Gas Heat, 2 Stage  
M = Medium Gas Heat, 2 Stage  
H = High Gas Heat, 2 Stage

**Blower Type**  
E = MSAV® Multi-Stage Air Volume (DirectPlus™ ECM Direct Drive)  
P = VAV Variable Air Volume (DirectPlus™ ECM Direct Drive)

**Refrigerant Type**  
4 = R-410A

## FEATURE HIGHLIGHTS

Lennox' Enlight™ rooftop units featuring the Lennox® CORE Control System create a bright future through a highly energy-efficient and environmentally sustainable design. Comprehensive configurations meet a wide range of applications, making it the most flexible product line Lennox has to offer.

1. Heat Exchanger/Inshot Burners
2. Scroll Compressors
3. Environ™ Coil System
4. Outdoor Coil Fan Motors
5. Heavy Gauge Steel Cabinet
6. Hinged Access Panels
7. DirectPlus™ Direct Drive ECM Blower System
8. Air Filters
9. Lennox® CORE Control System

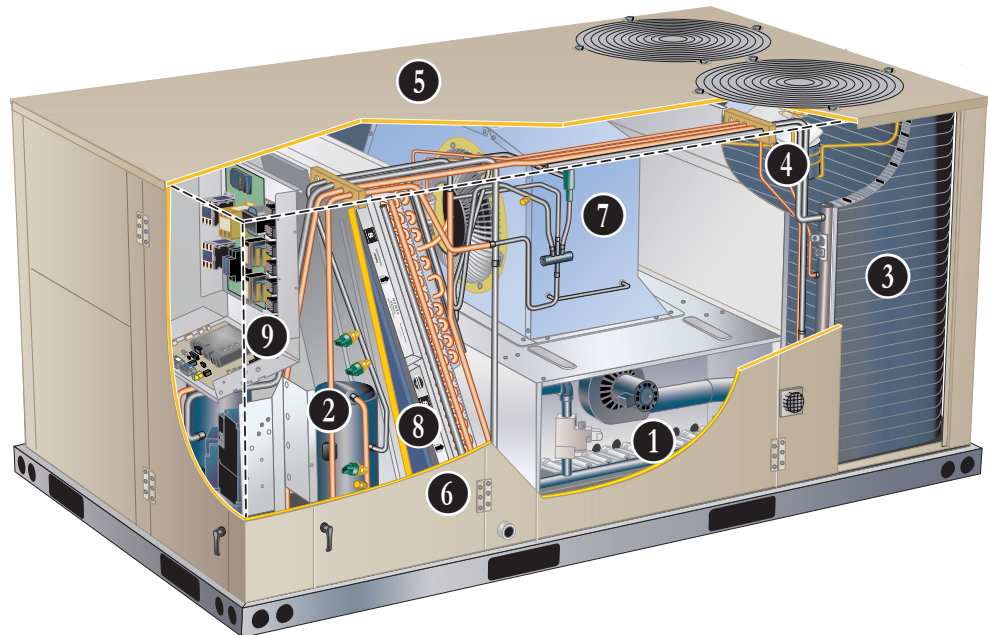

## CONTENTS

Approvals And Warranty . . . . .	3
Blower Data . . . . .	32
Dimensions . . . . .	39
- Accessories . . . . .	40
- Unit . . . . .	39
Electrical Data . . . . .	35
Features And Benefits . . . . .	3
High Altitude Derate . . . . .	25
Humiditrol® Dehumidification System Option . . . . .	12
Humiditrol® Dehumidification System Ratings . . . . .	30
Model Number Identification. . . . .	1
Optional Conventional Temperature Control Systems . . . . .	13
Options / Accessories . . . . .	20
Outdoor Sound Data . . . . .	37
Ratings . . . . .	26
Sequence Of Operation. . . . .	15
Specifications . . . . .	23
- Gas Heat . . . . .	25
Unit Clearances . . . . .	37
Weight Data . . . . .	38
- Options / Accessories. . . . .	38
- Unit . . . . .	38

## APPROVALS AND WARRANTY

### APPROVALS

- AHRI Standard 340/360 certified
- ETL and CSA listed
- Efficiency rating certified by CSA
- Components bonded for grounding to meet safety standards for servicing required by ETL, NEC and CEC
- All models are ASHRAE 90.1 compliant
- All models meet DOE 2023 energy efficiency standards
- All models meet California Code of Regulations, Title 24 and ASHRAE 90.1-2022 Section 6.4.3.10 requirements for staged airflow
- ISO 9001 Registered Manufacturing Quality System

### WARRANTY

- Aluminized Heat Exchanger - Limited ten years
- Stainless Steel Heat Exchanger (optional) - Limited fifteen years
- Compressors - Limited five years
- Environ™ Coil System - Limited three years
- Lennox® CORE Unit Controller - Limited three years
- High Performance Economizers (optional) - Limited five years
- All other covered components - Limited one year

## FEATURES AND BENEFITS

### HEATING SYSTEM

- 1 • Aluminized steel inshot burners
  - Direct spark ignition
  - Electronic flame sensor
  - Combustion air inducer
  - Redundant automatic dual stage gas valve with manual shut-off

#### Heat Exchanger

- Tubular construction, aluminized steel
- Life-cycle tested

**NOTE** - Optional Stainless Steel Heat Exchanger is required if mixed air temperature is below 45°F.

#### Electronic Pilot Ignition

- Electronic spark igniter provides positive direct ignition of burners on each operating cycle
- Permits main gas valve to stay open only when the burners are proven to be lit
- If loss of flame occurs, gas valve closes, shutting off the gas to the burners
- LED indicates status and aids in troubleshooting
- Watchguard circuit on module automatically resets ignition controls after one hour of continuous thermostat demand after unit lockout, eliminating nuisance service calls
- Factory installed in the gas heating compartment

#### Limit Controls

- Redundant limit controls with fixed temperature setting
- Protects heat exchanger and other components from overheating

#### Safety Switches

- Flame roll-out switch
- Flame sensor
- Combustion air inducer proving switch
- Protects system operation

#### Required Selections

##### Gas Input Choice - Order one:

- Standard Gas Heat, 2 Stage (84,500/130,000 Btuh)
- Medium Gas Heat, 2 Stage (117,000/180,000 Btuh)
- High Gas Heat, 2 Stage (156,000/240,000 Btuh)

#### Options/Accessories

##### Factory Installed

##### Stainless Steel Heat Exchanger

- Required if mixed air temperature is below 45°F

##### Field Installed

##### Bottom Gas Piping Kit

- Allows bottom gas entry

##### Low Temperature Vestibule Heater

- Electric heater automatically controls minimum temperature in gas burner compartment when temperature is below -40°F
- CSA certified to allow operation of unit down to -60°F

## FEATURES AND BENEFITS

### HEATING SYSTEM (continued)

#### Options/Accessories

#### Field Installed

##### Combustion Air Intake Extensions

- Recommended for use with existing flue extension kits in areas where high snow areas can block intake air

##### LPG/Propane Kits

- Conversion kit to field change over units from Natural Gas to LPG/Propane

##### Vertical Vent Extension Kit

- Use to exhaust flue gases vertically above unit
- Required when unit vent is too close to fresh air intakes per building codes
- Also prevents ice formation on intake louvers
- Kit contains vent transition, vent tee, drain cap, and installation hardware

**NOTE** - Straight vent pipes (4 in. B-Vent) and caps are not furnished and must be field supplied. Refer to kit instructions for additional information.

### COOLING SYSTEM

- Designed to maximize sensible and latent cooling performance at design conditions
- System can operate from 0°F to 125°F without any additional controls

#### R-410A Refrigerant

- Non-chlorine based
- Ozone-friendly

#### 2 Compressor System

- System consists of one two-stage scroll compressor and one single-stage scroll compressor
- Resiliently mounted on rubber grommets for quiet operation

#### Compressor Crankcase Heaters

- Protects against refrigerant migration that can occur during low ambient operation or during extended off cycles

#### Thermal Expansion Valves

- Ensures optimal performance throughout the application range
- Removable element head

#### Filter/Driers

- High capacity filter/drier protects the system from dirt and moisture

#### High Pressure Switches

- Protects the compressor from overload conditions such as dirty condenser coils, blocked refrigerant flow or loss of outdoor fan operation

#### Low Pressure Switches

- Protects the compressors from low pressure conditions such as low refrigerant charge or low/no airflow

#### Indoor Coil Freeze Protection

- Protects the evaporator coil from damaging ice build-up due to conditions such as low/no airflow, or low refrigerant charge

#### 3 Condenser Coil - Environ™ Coil System

- Lightweight, all aluminum brazed fin construction
- Constructed of three components
  - A flat extrusion tube
  - Fins in-between the flat extrusion tube
  - Two refrigerant manifolds

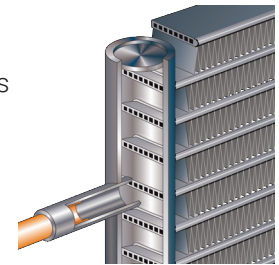

#### Environ™ Coil System Features:

- Improved heat transfer performance due to high primary surface area (flat tubes) versus secondary surface (fins)
- Smaller internal volume (reduced refrigerant charge)
- High durability
- All aluminum construction
- Fewer brazed joints
- Compact design
- Reduced unit weight
- Easy maintenance/cleaning
- Mounting brackets with rubber inserts secure coil to unit providing vibration dampening and corrosion protection
- Angled cabinet design protects coil from damage

#### Evaporator Coil

- Copper tube construction
- Enhanced rippled-edge aluminum fins
- Flared shoulder tubing connections
- Silver soldered construction
- Factory leak tested
- Cross-row circuiting with rifled tubing

#### Antimicrobial Condensate Drain Pan

- Composite pan, sloped to meet drainage requirements per ASHRAE 62.1
- Antimicrobial additive prevents growth of mold and mildew, which improves indoor air quality and reduces drain line blockage
- Side or bottom drain connections
- Reversible to allow connection at back of unit

#### 4 Outdoor Coil Fan Motors

- Thermal overload protected
- Totally enclosed
- Permanently lubricated ball bearings
- Shaft up
- Wire basket mount

#### Outdoor Coil Fans

- PVC coated fan guard furnished

## FEATURES AND BENEFITS

### COOLING SYSTEM (continued)

#### Required Selections

##### Cooling Capacity

- Specify nominal cooling capacity

#### Options/Accessories

##### Factory or Field Installed

##### Condensate Drain Trap

- Constructed of PVC (factory or field) or copper (field only)

**NOTE** - Trap is field installed only; PVC version may be factory ordered to ship with unit.

##### Drain Pan Overflow Switch

- Monitors condensate level in drain pan
- Shuts down unit if drain becomes clogged

### CABINET

#### 5 Construction

- Heavy-gauge steel panels
- Full perimeter heavy-gauge galvanized steel base rail
- Base rails have rigging holes
- Three sides of the base rail have forklift slots
- Raised edges around duct and power entry openings in the bottom of the unit for water protection

##### Airflow Choice

- Units are shipped in downflow (vertical) return air flow configuration

**NOTE** - Units can be field converted to horizontal airflow with optional Horizontal Discharge Kit.

##### Duct Flanges

- Provided for horizontal duct attachment

##### Power/Gas Entry

- Electrical and gas lines can be routed through the unit base or through horizontal access knock-outs

##### Exterior Panels

- Constructed of heavy-gauge, galvanized steel
- Textured pre-paint with polyurethane finish
- Cyclic salt fog and UV exposure up to 1680 hours per ASTM D5894

##### Insulation

- Fully insulated with non-hygroscopic fiberglass insulation (conditioned areas)
- Unit base is fully insulated
- Base insulation serves as an air seal to the roof curb, eliminating the need to add a seal during installation

#### 6 Hinged Access Panels

- Tool-less access
- Filter section
- Blower/heating section
- Compressor/controls section
- Panel seals and quarter-turn latching handles provide a tight air and water seal

### Required Selections

#### Airflow Configuration

- Specify downflow or horizontal

### Options/Accessories

#### Factory or Field Installed

##### Return Air Adaptor Plate

- For same size LC/LG/LH and TC/TG/TH unit replacement
- Installs on return air opening in unit to match return air opening on existing roof curbs
- Also see Accessory Air Resistance table

##### Combination Coil/Hail Guards

- Heavy gauge steel frame
- Painted to match cabinet
- Expanded metal mesh protects outdoor coil

#### Factory Installed

##### Corrosion Protection

- Completely flexible immersed coating
- Electrodeposited dry film process (AST ElectroFin E-Coat)
- ASTM B117 / DIN 53167 Salt Spray - 15,000+ hours
- ASTM G85 Annex A3 SWAAT Modified Salt Spray - 3,000 hours
- VA Master Construction Specification Division 23 for High Humidity Installations
- CID AA-52474A (GSA)
- Indoor Corrosion Protection:
  - Coated coil
  - Coated reheat coil
  - Painted blower housing
  - Painted base
- Outdoor Corrosion Protection:
  - Coated coil
  - Painted outdoor base

#### Field Installed

##### Horizontal Discharge Kit

- Consists of duct covers to block off downflow supply and return air openings for horizontal applications
- Also includes return air duct flanges for end return air when economizer is used in horizontal applications

**NOTE** - When configuring unit for horizontal application with economizer, a separate Horizontal Barometric Relief Damper with Hood must be ordered separately for installation in the return air duct.

## FEATURES AND BENEFITS

### **BLOWER**

#### **7 DirectPlus™ Blower System**

- High-efficiency, variable-speed ECM (electronically commutated) motor
- Eliminates the need for a separate variable-frequency drive
- MSAV® Multi-Stage Air Volume control modulates the amount of supply blower airflow according to cooling demand, heating demand, ventilation demand or smoke alarm
- The amount of airflow for each stage can be set according to a parameter in the Lennox® CORE Unit Controller
- Unit is shipped from the factory with preset airflows
- Fully variable speed motor modulates to maximize system efficiency
- Combines the motor and electronics into one unit
- Aerodynamically optimized impeller
- Backward curved blades mounted directly onto the rotor



- Air inlet grill reduces indoor sound levels without affecting air performance

#### **Supply Static Pressure Transducer (VAV Models Only)**

- Sends information to the Lennox® CORE Unit Controller to control blower speed to the desired supply duct static pressure
- Shipped with the unit for remote field installation in the supply duct

### **Required Selections**

#### **Blower Selection**

- MSAV® Multi-Stage Air Volume controls the speed of the blower based on the cooling and heating demands
- VAV (Variable Air Volume) blower varies the air volume to maintain a constant supply duct static pressure

### **ELECTRICAL**

#### **SmartWire™ System**

- Keyed and color-coded wiring connectors prevent miswiring
- Wire coloring scheme is standardized across all models
- Each connection is intuitively labeled to make troubleshooting and servicing quick and easy

#### **Electrical Plugs**

- Positive connection electrical plugs are used to connect common accessories or maintenance parts for easy removal or installation

#### **Phase/Voltage Detection**

- Monitors power supply to assure phase is correct at unit start-up
  - If phase is incorrect, the unit will not start and an alarm code is reported to the unit controller
- Protects unit from being started with incorrect phasing which could lead to issues such as compressors running backwards
- Voltage detection monitors power supply voltage to assure proper voltage
  - If voltage is not correct (over/under voltage conditions) the unit will not start and an alarm code is reported to the unit controller

### **Required Selections**

#### **Voltage Choice**

- Specify when ordering base unit

### **Options/Accessories**

#### **Factory Installed**

##### **Circuit Breakers**

- HACR type
- For overload and short circuit protection
- Factory wired and mounted in the power entry panel
- Current sensitive and temperature activated
- Manual reset

##### **Short-Circuit Current Rating (SCCR)**

- Higher short circuit protection up to 100kA

**NOTE** - Disconnect Switch is furnished and factory installed with High SCCR option.

#### **Factory or Field Installed**

##### **Disconnect Switch**

- Accessible outside of unit
- Spring loaded weatherproof cover furnished

##### **GFI Service Outlets (2)**

- 115V ground fault circuit interrupter (GFCI) type options:
- Factory installed, powered and wired
- Factory installed, non-powered, field wired
- Field installed, non-powered, field wired

#### **Field Installed**

##### **GFI Weatherproof Cover**

- Single-gang cover
- Heavy-duty, UV-resistant, polycarbonate case construction
- Hinged base cover with gasket

## FEATURES AND BENEFITS

### INDOOR AIR QUALITY

#### 8 Air Filters

- Disposable 2 inch MERV 4 filters furnished as standard

#### Options/Accessories

#### Factory or Field Installed

##### Healthy Climate® High Efficiency Air Filters

- Disposable MERV 8 and MERV 13 (Minimum Efficiency Reporting Value based on ASHRAE 52.2) efficiency 2 inch pleated filters

#### Field Installed

##### Healthy Climate® High Efficiency MERV 16 Air Filters

- Disposable MERV 16 (Minimum Efficiency Reporting Value based on ASHRAE 52.2) efficiency 2 inch pleated filters

##### Healthy Climate® UVC Germicidal Light Kit

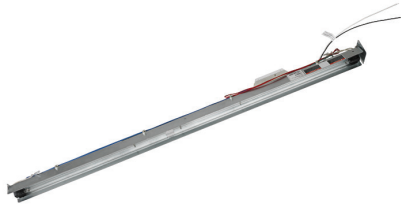

- Germicidal lamps emit ultra-violet (UV-C) energy, which has been proven to be effective in reducing microbes such as viruses, bacteria, yeasts, and molds
- UV-C energy greatly reduces the growth and proliferation of mold and other bioaerosols (bacteria and viruses) on illuminated surfaces (particularly coil and drain pan)
- Destroys the organism or controls its ability to reproduce
- Field installed in the blower/evaporator coil section
- Magnetic safety interlock terminates power when access panels are removed
- All necessary hardware for installation is included
- Lamps operate on 110/230V-1ph power supply

**NOTE** - Step-down transformer may be ordered separately for 460V and 575V units.

- Approved by ETL

#### Needlepoint Bipolar Ionization (NPBI) Kit

- NPBI technology integrates with system controls for effective air treatment
- Ionization has been shown to effectively reduce harmful pathogens, pollutants and odors

**NOTE** - Please visit [www.sciencedirect.com](http://www.sciencedirect.com) for additional information.

- Brush-type ionizer introduces a high concentration of both positive and negative ions into the airstream
- The bipolar ions are then dispersed into the occupied space through the duct system proactively reducing the airborne contaminants
- Ions travel within the building air stream and attach to particles, pathogens, and gas molecules, making them larger and easier to capture in the filtration system
- UL 2998 certified for zero ozone emission

#### Indoor Air Quality (CO<sub>2</sub>) Sensors

- Monitors CO<sub>2</sub> levels
- Reports to the Lennox® CORE Unit Controller, which adjusts economizer dampers as needed

#### Replacement Filter Media Kit With Frame

- Replaces existing pleated filter media
- Includes washable metal mesh screen and metal frame with clip for holding replaceable non-pleated filter

## CONTROL SYSTEM

### LENNOX® CORE CONTROL SYSTEM

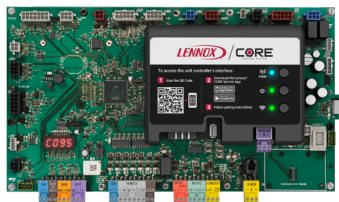

- 9 The Lennox® CORE Control system is designed to accelerate equipment install and service. Standard with all Enlight™ rooftop units, control system integrates key technologies that lower installation costs, drive system efficiency, and protect your investments.

The Lennox® CORE Unit Controller is a microprocessor-based controller that provides flexible control of all unit functions.

#### CORE Mobile Service App

- Guided Setup with progress indicators, detailed help, and exportable summaries to manage simple, trouble-free setup, reducing commissioning times
- Enhanced Test Functionality provides real-time sensor readings, trending, and reports that enable easy troubleshooting
- Ability to set and configure parameters of the CORE Control System to manage sequence of operation
- Economizer test function ensures economizer is operating correctly



#### Additional Features:

- Built-In 7-Segment Display shows Unit Status and active alarms for easy troubleshooting
- Buttons for test and clearing delays
- SmartWire™ System with keyed and removable screw terminals ensure correct field wiring
- Built-in BACnet MS/TP and IP allow open integration to building management systems
- Two-port Ethernet Switch enables daisy chaining for BACnet IP and automatic firmware updates

**NOTE** - Unit Internet Connection required.

- Profile setup copies key settings between units with the same configuration to reduce setup time
- USB port allows a technician to download and transfer unit information to help verify service was performed
- USB software updates on the Lennox® CORE Unit Controller enhance functionality without the need to change components
- Unit Controller Software

#### Configurable Built-In Functions

- Discharge Air Cooling Control
- Up to three distinct Cooling Airflows in Thermostat Mode
- Programmable independent heating, ventilation and cooling blower speeds

- Discharge Air Heating Control
- Economizer Control Options (See Economizer / Exhaust Air / Outdoor Air sections)
- Exhaust Fan Control Modes for fresh air damper position
- Configurable Morning Warm-up
- Night Setback Mode
- Fresh Air Tempering for Improved Ventilation
- Demand Control Ventilation
- Low Ambient Controls for operation down to 0°F
- Humiditrol™ Operation
- Enhanced Dehumidification (Latent Demand Control without reheat)

#### Component Protection / Unit Safeguards:

- Compressor Time-Off Delay
- Adjustable Blower On/Off Delay
- Return Air Temperature Limit Control
- Safety Switch Input allows Controller to respond to a external safety switch trip
- Service Relay Output
- Thermostat Bounce Delay
- Smoke Alarm Mode has four choices (unit off, positive pressure, negative pressure, purge)
- "Strike Three" Protection
- Gas Valve Time Delay Between First and Second Stage
- Minimum Compressor Run Time

#### Control Methods / Interfaces:

- DDC and 24V Thermostat
- BACnet MS/TP and IP
- LONTalk (Factory and Field Option)
- Lennox S-BUS
- Compatibility with Lennox Wireless Zone Sensors
- Zone Temperature Sensor Input
- Dehumidistat and Humidity Sensor Inputs
- Indoor Air Quality Inputs (2)
- Built-in Control Parameter Defaults
- Permanent Diagnostic Code Storage
- Field Adjustable Control Parameters (Over 200 settings)
- Multiple Configurable Digital Inputs
- LED Indicators
- PC Interface connects the Lennox® CORE Unit Controller to a PC with the Lennox Unit Controller Software

**NOTE** - Lennox® CORE Control System features vary with the type of rooftop unit in which the control is installed.



## CONTROL SYSTEM

### LENNOX® CORE CONTROL SYSTEM (continued)

#### Controls Options

#### Factory or Field Installed

##### Blower Proving Switch

- Monitors blower operation, shuts down unit if blower fails

##### Dirty Filter Switch

- Senses static pressure increase and issues alarm if necessary

##### Fresh Air Tempering

- Used in applications with high outside air requirements
- Controller energizes the first stage heat as needed to maintain a minimum supply air temperature for comfort, regardless of the thermostat demand
- When ordered as a factory option, sensor ships with the unit for field installation

##### Smoke Detector

- Photoelectric type
- Installed in supply air section, return air section or both sections
- Available with power board and single sensor (supply or return) or power board and two sensors (supply and return)
- Power board located in unit control compartment

##### Interoperability via BACnet® or LonTalk® Protocols

- Communication compatible with third-party automation systems that support the BACnet Application Specific Controller device profile, LonMark® Space Comfort Controller functional profile, or LonMark Discharge Air Controller functional profile

#### Commercial Control Systems

#### Field Installed

##### Thermostats

- Control system and thermostat options, see page 13

## OPTIONS / ACCESSORIES

### ECONOMIZER

- Economizer operation is set and controlled by the Lennox® CORE Control System
- Simple plug-in connections from economizer to control system for easy installation
- All Enlight™ rooftop units are equipped with factory installed CEC Title 24 approved sensors for outside, return and discharge air temperature monitoring

**NOTE** - Optional sensors may be used instead of unit sensors to determine whether outdoor air is suitable for free cooling. See the Options/Accessories table.

#### Factory or Field Installed

#### **10** High Performance Economizer

- Approved for California Title 24 building standards
- Low leakage dampers are Air Movement and Control Association International (AMCA) Class 1A Certified - Maximum 3 CFM per sq. ft. leakage at 1 in. w.g.
- ASHRAE 90.1 compliant
- Downflow or Horizontal with Outdoor Air Hood
- Outdoor Air Hood is included when economizer is factory installed and is furnished with economizer when ordered for field installation
- Linked damper action
- High torque 24-volt fully-modulating spring return damper motor
- Return air and outdoor air dampers
- Plug-in connections to unit

#### **11** Barometric Relief Dampers with Exhaust Hood are also furnished

**NOTE** - Horizontal applications use furnished outdoor air hood and barometric relief dampers with exhaust hood. Requires optional Horizontal Discharge Kit. See dimension drawing on page 41

Horizontal applications in reduced spaces requires optional Horizontal Low Profile Barometric Relief Dampers with Exhaust Hood and Horizontal Discharge Kit. See dimension drawing on page 42

**NOTE** - High Performance Economizers are not approved for use with enthalpy controls in Title 24 applications.

**NOTE** - The Free Cooling setpoint for Title 24 applications must be set based on the Climate Zone where the system is installed. See Section 140.4 "Prescriptive Requirements for Space Conditioning Systems" of the California Energy Commission's 2022 Building Energy Efficiency Standards.

**NOTE** - Refer to Installation Instructions for complete setup information.

## OPTIONS / ACCESSORIES

### **ECONOMIZER (continued)**

#### **Factory or Field Installed**

##### **Differential Sensible Control**

- Factory setting
- Uses outdoor air and return air sensors that are furnished with the unit
- The Lennox® CORE Control System compares outdoor air temperature with return air and activates the economizer when the outdoor air is below the configured setpoint and cooler than return air

**NOTE** - Differential Sensible Control can be configured in the field to provide Offset Differential Sensible Control or Single Sensible Control.

In Offset Differential Sensible Control mode, the economizer is enabled if the temperature differential (offset) between outdoor air and return air reaches the configured setpoint.

In Single Sensible Control mode, the economizer is enabled when outdoor air temperature falls below the configured setpoint.

##### **Global Control**

- The unit controller communicates with a DDC system with one global sensor (enthalpy or sensible)
- Determines whether outside air is suitable for free cooling on all units connected to the control system
- Sensor must be field provided

##### **Single Enthalpy Control (Not for Title 24)**

- Outdoor air enthalpy sensor enables economizer if the outdoor enthalpy is less than the setpoint of the control

##### **Differential Enthalpy Control (Not for Title 24)**

- Order two Single Enthalpy Controls
- One is field installed in the return air section
- One is installed in the outdoor air section
- Allows the economizer control to select between outdoor air or return air, whichever has lower enthalpy

#### **Field Installed**

##### **Outdoor Air CFM Control**

- Maintains constant outdoor air volume levels on the supply air fan and varying unit airflows
- Velocity sensor located in the rooftop unit outdoor air section, the Lennox® CORE Control System changes the economizer position to help minimize the effect of supply fan speed changes on outdoor air volume levels
- Setpoint for outdoor air volume is established by field testing

**NOTE** - Not available with Demand Control Ventilation (CO<sub>2</sub> Sensor) or Building Pressure Control.

##### **Building Pressure Control**

- Maintains constant building pressure level
- Includes a static pressure transducer and outdoor static pressure assembly
- Using differential pressure information between the outdoor air and the building air, the Lennox® CORE Control System changes the economizer position to help maintain a constant building pressure

**NOTE** - Not available with Demand Control Ventilation (CO<sub>2</sub> Sensor) or Outdoor Air CFM Control.

### **EXHAUST**

#### **Factory or Field Installed**

##### **Power Exhaust Fan**

- Installs internal to unit for downflow applications only with economizer option
- Provides exhaust air pressure relief
- Interlocked to run when supply air blower is operating
- Fan runs when outdoor air dampers are 50% open (adjustable)
- Motor is overload protected
- Fan is 20 in. diameter
- Five blades
- One 1/3 hp motor

**NOTE** - Requires Economizer and Downflow Barometric Relief Dampers.

#### **Field Installed**

##### **Horizontal Low Profile Barometric Relief Dampers**

- For use when unit is configured for horizontal applications requiring an economizer in a reduced space
- Allows relief of excess air
- Aluminum blade dampers prevent blow back and outdoor air infiltration during off cycle
- Field installed in return air duct
- Bird screen and hood furnished

**NOTE** - Requires Horizontal Discharge Kit.

## OPTIONS / ACCESSORIES

### **OUTDOOR AIR**

#### **Factory or Field Installed**

##### **Outdoor Air Damper**

- Downflow or Horizontal
- Linked mechanical dampers
- 0 to 25% (fixed) outdoor air adjustable
- Installs in unit
- Includes outdoor air hood
- Motorized model features fully modulating spring return damper motor with plug-in connection
- Manual model features parallel blade, gear-driven dampers with adjustable fixed position

**NOTE** - Outdoor Air Hood is included when damper is factory installed and is furnished with damper when ordered for field installation.

**NOTE** - Manual Outdoor Air Damper is a field installed option only.

### **ROOF CURBS**

#### **Field Installed**

- Nailer strip furnished (downflow only)
- Mates to unit
- US National Roofing Contractors Approved
- Shipped knocked down

#### **Hybrid Roof Curbs, Downflow**

- Interlocking tabs fasten corners together
- No tools required for assembly
- Can also be fastened together with furnished hardware
- Available in 8, 14, 18, and 24 inch heights

#### **Adjustable Pitch Curb**

- Fully adjustable pitch curbs (3/4 in. per foot in any direction) provide a level platform for rooftop units allowing flexible installations on roofs with uneven or sloped angles
- Interlocking tabs fasten corners together
- No tools required for assembly
- Hardware is furnished to connect upper curb with lower curb
- Available in 14 inch height

#### **Adaptor Curbs (not shown)**

- Curbs are regionally sourced
- Dimensions vary based upon the source

**NOTE** - Contact your local sales representative for a detailed cut sheet with applicable dimensions.

### **CEILING DIFFUSERS**

#### **Field Installed**

##### **Ceiling Diffusers (Flush or Step-Down)**

- White powder coat finish on diffuser face and grilles
- Insulated UL listed duct liner
- Diffuser box has collars for duct connection
- Step-down diffusers have double deflection blades
- Flush diffusers have fixed blades
- Provisions for suspending
- Internally sealed to prevent recirculation
- Removable return air grille
- Adapts to T-bar ceiling grids or plaster ceilings

##### **Transitions (Supply and Return)**

- Used with diffusers
- Installs in roof curb
- Galvanized steel construction
- Flanges furnished for duct connection to diffusers
- Fully insulated

# HUMIDITROL® DEHUMIDIFICATION SYSTEM OPTION

## OVERVIEW

- Factory installed option designed to control humidity
- Provides dehumidification on demand using ASHRAE 90.1 recommended method for comfort conditioning humidity control
- Unit comes equipped with one row reheat coil, solenoid valve and humidity controller
- A thermostat with a dehumidification output, a dehumidistat, or a DDC controller with an isolated output is required to control humidity and must be located in the occupied space

**NOTE** - Controls are not furnished and must be ordered separately.

## BENEFITS

- Improves indoor air quality
- Helps prevent damage due to high humidity levels
- Improves comfort levels by reducing space humidity levels

## OPERATION

### No Dehumidification Demand

- The unit will operate conventionally whenever there is a demand for cooling or heating and no dehumidification demand
- Free cooling is only permitted when there is no demand for dehumidification

### Dehumidification Demand Only

- Dehumidification is initiated by an output from a thermostat with a dehumidification output, a dehumidistat, or a DDC controller with an isolated output to control humidity

- Reheat operation will initiate on a dehumidification demand and does not require a cooling demand
- The unit will operate in the dehumidification mode until the relative humidity of the conditioned space is below the setpoint
- This reduces sensible cooling capacity and extends compressor run time to control humidity when the cooling load is low
- A solenoid valve diverts hot gas from the compressor to the reheat coil
- The cooled and dehumidified air from the evaporator is reheated as it passes through the reheat coil
- The de-superheated and partially condensed refrigerant continues to the outdoor condenser coil where condensing is completed
- Unit will continue to operate in this mode until the dehumidification demand is satisfied

**NOTE** - See Sequence of Operation for additional information.

### Dehumidification and Cooling Demand (Thermostat/ Room Sensor Application)

- If both a dehumidification and a full cooling load demand occur, the system will operate in cooling until the cooling demand is satisfied
- Then the system will energize the dehumidification mode

## Options / Accessories

### Humidity Sensor Kit

- Remote mounted dehumidistat for factory installed Humiditrol® option
- Adjustable 20-80%

**NOTE** - A thermostat with a dehumidification output or a DDC controller with an isolated output can be used instead.

REFRIGERANT SCHEMATIC

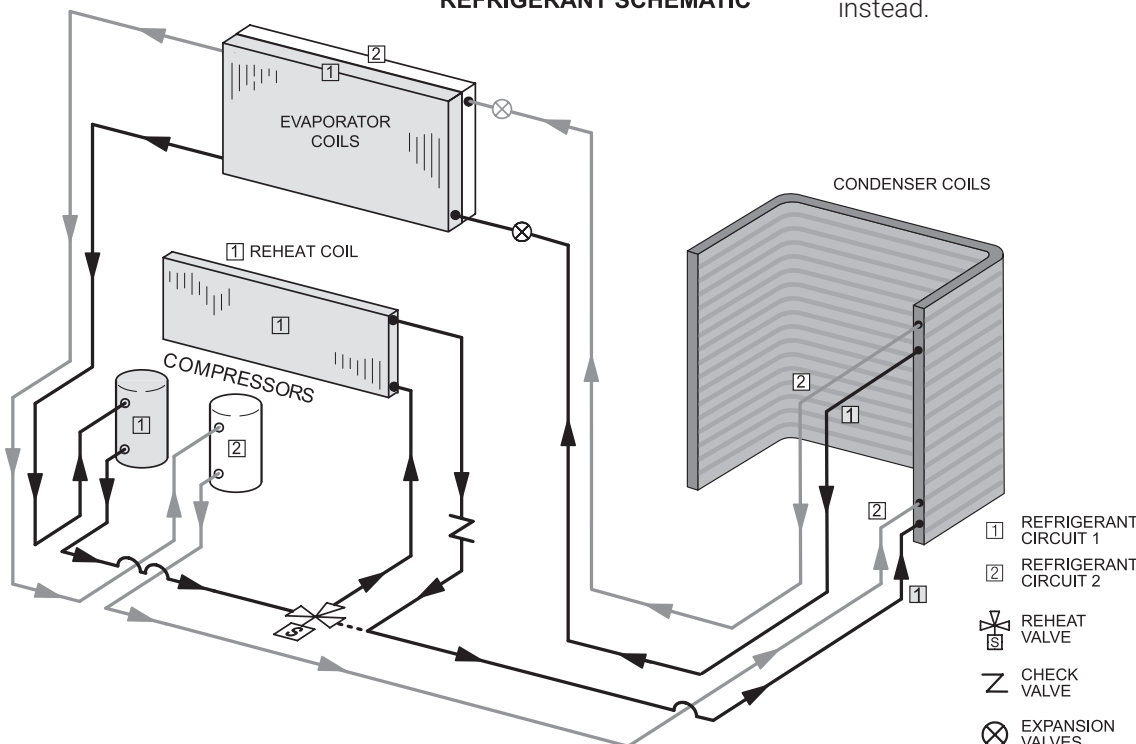

## OPTIONAL CONVENTIONAL TEMPERATURE CONTROL SYSTEMS

### CS8500 Commercial 7-Day Programmable Thermostat

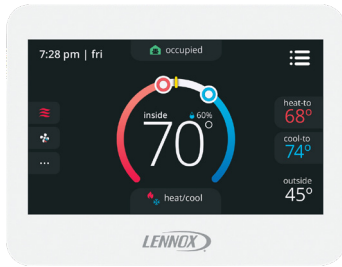

- Fully Communicating Sensor
- Full Color Touchscreen Interface
- Variable Speed System Control (On Compatible Units)
- Up To 4 Heat / 4 Cool
- Built-In Sensors For Temperature, Humidity And Optional CO<sub>2</sub>
- Remote Sensor Options For Occupancy, Temperature
- BACnet Capable Options
- 5-2 or 7-Day Scheduling
- Smooth Setback Recovery
- Heat/Cool Auto-Changeover
- Four-Wire Installation
- FDD, ASHRAE, IECC Compliant

### CS7500 Commercial 7-Day Programmable Thermostat



- Premium Universal Thermostat
- Full Color Touchscreen Interface
- Up To 4 Heat / 3 Cool
- Built-In Sensors For Temperature and Humidity
- Remote Sensors Options For Temperature, Discharge Air, Outdoor Air
- 5-2 or 7-Day Scheduling
- Smooth Setback Recovery
- Heat/Cool Auto-Changeover
- FDD, ASHRAE, IECC Compliant

### CS3000 Commercial 5-2 Day Programmable Thermostat

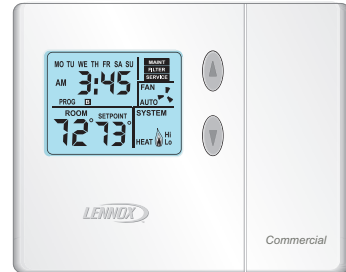

- Conventional Multi-Stage Thermostat
- Intuitive Display
- Push-Button Operation
- Up To 2 Heat / 2 Cool
- Built-In Temperature Sensor
- Remote Temperature Sensing
- Up to 5-2 Day Scheduling
- Smooth Setback Recovery
- Heat/Cool Auto-changeover

### Wireless/Wired Temperature/Humidity Room Sensor (LCS-5030)



- Simple Push-Button Override
- Variable Speed System Control (On Compatible Units)
- Up To 4 Heat / 4 Cool
- AA Battery / 24VAC Powered
- Bluetooth™ Mesh Operation
- SBUS Wired Operation
- Automatic Sensor Averaging
- Locking Hex Screw

### Wireless Repeater for LCS-5030



- Extends Effective Range of Wireless Sensor (LCS-5030)
- 24VAC Only
- Locking Hex Screw

**NOTE** - Wireless only.

## OPTIONAL CONVENTIONAL TEMPERATURE CONTROL SYSTEMS

### Wired Temperature/Humidity Room Sensor (Non-Communicating)



- Terminal blocks for wiring connections
- Five-wire sensor connection
- Off-white plastic enclosure
- Non-adjustable
- Relative humidity range: 0 -100%
- +/- 3% Accuracy

## OPTIONAL CONVENTIONAL TEMPERATURE CONTROL SYSTEMS

Description	Catalog No.
<b>CS8500 Commercial 7 Day Programmable Thermostat</b>	
CS8500 7-Day Thermostat	No CO <sub>2</sub> Sensing <b>17G75</b>
	With CO <sub>2</sub> Sensing <b>17G76</b>
Sensors/Accessories	<sup>1</sup> Remote non-adjustable wall-mount 10k <b>47W37</b>
	<sup>1</sup> Remote non-adjustable wall-mount 11k <b>94L61</b>
<b>Sysbus Network Cable (Yellow) for CS8500 and LCS-5030 Wired Room Sensor</b>	
Twisted pair 100% shielded communication cable, Red and Black	500 ft. box <b>27M19</b>
22 AWG, yellow jacket, rated at 75°C, 300V, Plenum rated	1000 ft. box <b>94L63</b>
Insulation - Low smoke PVC, NEC, CMP	2500 ft. roll <b>68M25</b>
<b>CS7500 Commercial 7-Day Programmable Thermostat</b>	
CS7500 7-Day Thermostat	<b>24K41</b>
Sensors/Accessories	<sup>2</sup> Remote non-adjustable wall-mount 20k <b>47W36</b>
	<sup>2</sup> Remote non-adjustable wall-mount 10k <b>47W37</b>
	Remote non-adjustable discharge air (duct mount) <b>19L22</b>
	Outdoor temperature sensor <b>X2658</b>
<b>CS3000 Commercial 5-2 Day Programmable Thermostat</b>	
CS3000 5-2 Day Thermostat	<b>11Y05</b>
Sensors/Accessories	Remote non-adjustable wall mount 10k averaging <b>47W37</b>
	Thermostat wall mounting plate <b>X2659</b>
<b>Universal Thermostat Guard with Lock (clear)</b>	
	Inside Dimensions (H x W x D) 5-7/8 x 8-3/8 x 3 in. <b>39P21</b>
<b>Temperature/Humidity Room Sensors</b>	
LCS-5030 Wireless/Wired Temperature/Humidity Room Sensor	<b>21L07</b>
Wireless Repeater for LCS-5030	<b>21L09</b>
A335MT13AE1 Wired Temperature/Humidity Room Sensor (Non-Communicating)	<b>21W06</b>

<sup>1</sup> Up to nine of the same type remote temperature sensors can be connected in parallel.

<sup>2</sup> Remote wall-mount sensors can be applied in any of the following combinations:

One Sensor - (1) 47W36, Two Sensors - (2) 47W37, Three Sensors - (2) 47W36 and (1) 47W37

Four Sensors - (4) 47W36, Five Sensors - (3) 47W36 and (2) 47W37

**Objective:** Outline the unit functions as a result of room thermostat or zone sensor demands.

**Given:** When economizer is present, it will function as an integral part of the unit cooling system. When not present, unit will function as if economizer is present but outdoor ambient is high and sensed as not suitable.

### **UNIT OPERATION WITH 2-STAGE THERMOSTAT (2 COOL AND 2 HEAT STAGES, Y1, Y2, W1, W2)**

#### **SUPPLY AIR BLOWER SPEED**

Unit has following supply air blower speed setting:

- Ventilation speed
- Cooling Speed - Low
- Cooling Speed - High
- Heating speed
- Smoke speed (Used only in smoke removal option - not discussed)

#### **<sup>1</sup> UNIT FEATURES AN ECONOMIZER AND OUTDOOR AIR IS SUITABLE**

Cooling - Thermostat Mode (Y1, Y2)

##### **Y1 Demand:**

All compressors are off, supply air blower is on low cooling speed to minimize blower power consumption, economizer modulates (minimum to maximum open position) to maintain 55°F supply air temperature (default unit controller setting).

##### **Y2 Demand:**

All compressors are off, supply air blower is on high cooling speed providing higher cooling capacity, and economizer modulates to maintain 55°F supply air temperature.

If economizer stays at maximum open for 3 minutes, compressor 1 is energized while supply air blower stays on high cooling speed providing maximum cooling capacity.

<sup>1</sup> *Outdoor air suitability is determined by the energy state of outdoor ambient (enthalpy or sensible) and its ability to achieve the desired free cooling effects. Outdoor air suitability can also be determined by a third party controller and provided to the rooftop unit via a network connection.*

#### **UNIT DOES NOT FEATURE AN ECONOMIZER OR OUTDOOR AIR IS NOT SUITABLE**

##### **Y1 Demand:**

Compressor 1 operates and supply air blower operates at low cooling speed.

##### **Y2 Demand:**

All compressors operate and supply air blower operates at high cooling speed.

#### **Dehumidification Mode**

If a unit with Humiditrol® Dehumidification Option receives a call for dehumidification, economizer free cooling is locked out.

##### **Call For Dehumidification, No Y1, Y2 demand:**

1st stage compressor operates, supply air blower operates at low cooling speed, and the reheat valve is energized.

##### **Y1 Demand With A Call For Dehumidification:**

All compressors operate, supply air blower operates at high cooling speed and the reheat valve is energized.

##### **Y2 Demand With A Call For Dehumidification:**

All compressors operate, supply air blower operates at high cooling speed, and the reheat valve is de-energized.

### **UNIT OPERATION WITH 3-STAGE THERMOSTAT OR ZONE SENSOR (3 COOL AND 2 HEAT STAGES, Y1, Y2, Y3 AND W1, W2)**

#### **SUPPLY AIR BLOWER SPEED**

Unit has following supply air blower speed setting:

- Ventilation speed
- Cooling Speed - Low
- Cooling Speed - Medium
- Cooling Speed - High
- Heating speed
- Smoke speed (Used only in smoke removal option - not discussed)

#### **<sup>1</sup> Unit Features An Economizer And Outdoor Air Is Suitable**

Cooling - Thermostat or Zone Sensor Mode (Y1, Y2, Y3)

##### **Y1 Demand:**

All compressors are off, supply air blower is on low cooling speed to minimize blower power consumption, economizer modulates (minimum to maximum open position) to maintain 55°F supply air temperature (default unit controller setting).

##### **Y2 Demand:**

All compressors are off, supply air blower is on high cooling speed providing higher cooling capacity, and economizer modulates to maintain 55°F supply air temperature.

If economizer stays at maximum open for 3 minutes, compressor 1 is energized while supply air blower stays on high cooling speed providing maximum cooling capacity. After compressors are energized the economizer stays at maximum open.

##### **Y3 Demand:**

Compressors 1 and 2 are energized while supply air blower stays on high cooling speed.

<sup>1</sup> *Outdoor air suitability is determined by the energy state of outdoor ambient (enthalpy or sensible) and its ability to achieve the desired free cooling effects. Outdoor air suitability can also be determined by a third party controller and provided to the rooftop unit via a network connection.*

#### **Unit Does Not Feature An Economizer or Outdoor Air Is Not Suitable**

##### **Y1 Demand:**

Compressor 1 operates at part load and supply air blower operates at low cooling speed.

##### **Y2 Demand:**

Compressor 1 operates at part load with compressor 2 ON, and supply air blower operates at medium cooling speed.

##### **Y3 Demand:**

All compressors operate and supply air blower operates at high cooling speed.

#### **Dehumidification Mode**

If a unit with Humiditrol® Dehumidification Option receives a call for dehumidification, economizer free cooling is locked out.

##### **Call For Dehumidification, No Y1, Y2 Demand:**

1st stage compressor operates, supply air blower operates at low cooling speed, and the reheat valve is energized.

##### **Y1 Demand With A Call For Dehumidification:**

All compressors operate, supply air blower operates at medium cooling speed and the reheat valve is energized.

##### **Y2 Demand With A Call For Dehumidification:**

All compressors operate, supply air blower operates at high cooling speed and the reheat valve is energized.

##### **Y3 Demand With A Call For Dehumidification:**

All compressors operate, supply air blower operates at high cooling speed, and the reheat valve is de-energized.



**HEATING MODE (GAS HEAT)**

NOTE - HEATING MODE IS THE SAME FOR ALL CONTROL OPTIONS

**W1 Demand:**

Gas valves are open (stage 1 on units with 2-stage gas valves) and supply air blower operates at heating speed.

**W2 Demand:**

Gas valves are open (stage 2 on units with 2-stage gas valves) and supply air blower operates at heating speed.

**OUTDOOR AIR DAMPER**

The minimum damper position for "occupied low blower" and "occupied high blower" is adjusted during unit setup to provide minimum fresh air requirements per ASHRAE 62.1 at the corresponding supply air blower speeds.

When supply air blower is off or the unit is in unoccupied mode, the outdoor air damper is closed.

When unit is in occupied mode and supply air blower is operating at a speed below the "midpoint" blower speed, the outdoor air damper is at minimum "low blower" position.

When unit is in occupied mode and supply air blower is operating at a speed equal to or above the "midpoint" blower speed, the outdoor air damper is at minimum "high blower" position.

*NOTE - The "midpoint" blower speed is an average of the minimum and maximum blower speed (minimum speed + maximum speed divided by 2).*

**POWER EXHAUST**

NOTE - POWER EXHAUST OPERATION IS THE SAME FOR ALL CONTROL OPTIONS

Single-stage power exhaust fan is an option available to units with Economizer and for downflow applications only.

Power exhaust fan operates when economizer outdoor air dampers are 50% open (adjustable) and when supply air blower is ON.

**UNITS IN ZONING APPLICATIONS OPERATING WITH DISCHARGE AIR CONTROL (2 HEAT / 3 COOL)****SUPPLY AIR BLOWER SPEED**

Unit has the following supply air blower speed settings:

- Ventilation Speed
- Cooling Speed - Fully modular based on supply duct static pressure
- Heating Speed
- Smoke Speed (Used only in smoke removal option - not discussed)

**COOLING MODE**

Discharge air temperature (DAT) can be used to control unit staging.

DAT default setpoint = 55°F. Unit will stage compressors as required to maintain the setpoint when provided with Y1 thermostat demand.

Increasing compressor stages provides more cooling capacity while decreasing compressor stages provides less cooling capacity.

**<sup>1</sup> Unit Features An Economizer And Outdoor Air Is Suitable****Y1 Demand:**

All compressors are off, supply air blower operates to maintain duct static pressure, economizer modulates (minimum to maximum open position) to maintain 55°F supply air temperature (default unit controller setting).

**Y2 Demand:**

All compressors are off, supply air blower operates to maintain duct static pressure, and economizer modulates to maintain 55°F supply air temperature. If economizer stays at maximum open for 3 minutes, compressor 1 is energized while supply air blower operates to maintain duct static pressure. After compressor 1 is energized, the economizer stays at maximum open.

**Y3 Demand:**

Compressor 1 and 2 are energized while supply air blower operates to maintain duct static pressure.

<sup>1</sup> Outdoor air suitability is determined by the energy state of outdoor ambient (enthalpy or sensible) and its ability to achieve the desired free cooling effects. Outdoor air suitability can also be determined by a third party controller and provided to the rooftop unit via a network connection.

**Unit Does Not Feature An Economizer Or Outdoor Air Is Not Suitable****Y1 Demand:**

Compressor 1 operates at part load and supply air blower operates to maintain duct static pressure.

**Y2 Demand:**

Compressors 1 operates at part load with compressor 2 ON and supply air blower operates to maintain duct static pressure.

**Y3 Demand:**

All compressors operate and supply air blower operates to maintain duct static pressure.

**HEATING MODE (2 Heat)**

Discharge air temperature (DAT) can be used to control unit staging.

DAT default setpoint = 110°F. Unit will stage heating as required to maintain the setpoint when provided with W1 demand.

Increasing heat stages provides more heating capacity while decreasing heat stages provides less heating capacity.

Blower operates to maintain Heating Static setpoint for all stages.

**W1 Demand:**

The first stage of mechanical heat is activated; gas valve one is in low fire mode. This is ~65% of heating capacity.

**W2 Demand:**

Gas valves are in high fire mode. This is 100% of heating capacity.

**MODULATING OUTDOOR AIR DAMPER**

The minimum damper position for “occupied low blower” and “occupied high blower” is adjusted during unit setup to provide minimum fresh air requirements per ASHRAE 62.1 at the corresponding supply air blower speeds.

- When supply air blower is off or the unit is in unoccupied mode, the outdoor air damper is closed.
- When unit is in occupied mode and supply air blower is operating at a speed below the “midpoint” blower speed, the outdoor air damper is at minimum “low blower” position.
- When unit is in occupied mode and supply air blower is operating at a speed equal to or above the “midpoint” blower speed, the outdoor air damper is at minimum “high blower” position.

*NOTE - The “midpoint” blower speed is an average of the minimum and maximum blower speed (minimum speed + maximum speed) divided by 2.*

## OPTIONS / ACCESSORIES

Item Description	Catalog Number	Unit Model No				
		092	102	120	150	
<b>COOLING SYSTEM</b>						
Condensate Drain Trap	PVC	<b>22H54</b>	OX	OX	OX	OX
	Copper	<b>76W27</b>	X	X	X	X
Drain Pan Overflow Switch		<b>21Z07</b>	OX	OX	OX	OX
<b>HEATING SYSTEM</b>						
Bottom Gas Piping Kit		<b>54W95</b>	X	X	X	X
Combustion Air Intake Extensions		<b>19W51</b>	X	X	X	X
Gas Heat Input	130,000 Btuh	Factory	O	O	O	O
	180,000 Btuh	Factory	O	O	O	O
	240,000 Btuh	Factory	O	O	O	O
Low Temperature Vestibule Heater	208/230V-3ph	<b>22A51</b>	X	X	X	X
	460V	<b>22A55</b>	X	X	X	X
	575V	<b>13X65</b>	X	X	X	X
LPG/Propane Conversion Kits	Standard Heat	<b>14N22</b>	X	X	X	X
	Medium Heat	<b>14N23</b>	X	X	X	X
	High Heat	<b>14N25</b>	X	X	X	X
Stainless Steel Heat Exchanger		Factory	O	O	O	O
Vertical Vent Extension Kit		<b>42W16</b>	X	X	X	X
<b>BLOWER - SUPPLY AIR</b>						
	DirectPlus™ Blower System with MSAV®	Factory	O	O	O	O
	DirectPlus™ Blower System with VAV	Factory	O	O	O	O
<b>CABINET</b>						
Combination Coil/Hail Guards		<b>24C85</b>	OX	OX	OX	OX
Corrosion Protection		Factory	O	O	O	O
Horizontal Discharge Kit		<b>51W25</b>	X	X	X	X
Return Air Adaptor Plate (for LC/LG/LH and TC/TG/TH unit replacement)		<b>54W96</b>	OX	OX	OX	OX
<b>CONTROLS</b>						
Blower Proving Switch		<b>21Z10</b>	OX	OX	OX	OX
Commercial Controls	CPC Einstein Integration	Factory	O	O	O	O
	LonTalk® Module	<b>54W27</b>	OX	OX	OX	OX
	Novar® LSE	Factory	O	O	O	O
Dirty Filter Switch		<b>53W67</b>	OX	OX	OX	OX
Fresh Air Tempering		<b>21Z08</b>	OX	OX	OX	OX
Smoke Detector - Supply or Return (Power board and one sensor)		<b>31A68</b>	OX	OX	OX	OX
Smoke Detector - Supply and Return (Power board and two sensors)		<b>31A69</b>	OX	OX	OX	OX

NOTE - Catalog and model numbers shown are for ordering field installed accessories.

OX - Configure To Order (Factory Installed) or Field Installed

O = Configure To Order (Factory Installed)

X = Field Installed

## OPTIONS / ACCESSORIES

Item Description	Catalog Number	Unit Model No				
		092	102	120	150	
<b>INDOOR AIR QUALITY</b>						
<b>Air Filters</b>						
Healthy Climate® High Efficiency Air Filters 20 x 25 x 2 (Order 4 per unit)	MERV 8	<b>50W61</b>	OX	OX	OX	OX
	MERV 13	<b>52W41</b>	OX	OX	OX	OX
	MERV 16	<b>21U41</b>	X	X	X	X
Replacement Media Filter With Metal Mesh Frame (includes non-pleated filter media)		<b>Y3063</b>	X	X	X	X
<b>Indoor Air Quality (CO<sub>2</sub>) Sensors</b>						
Sensor - Wall-mount, off-white plastic cover with LCD display		<b>77N39</b>	X	X	X	X
Sensor - Wall-mount, off-white plastic cover, no display		<b>23V86</b>	X	X	X	X
Sensor - Black plastic case with LCD display, rated for plenum mounting		<b>87N52</b>	X	X	X	X
Sensor - Wall-mount, black plastic case, no display, rated for plenum mounting		<b>87N54</b>	X	X	X	X
CO <sub>2</sub> Sensor Duct Mounting Kit - for downflow applications		<b>23Y47</b>	X	X	X	X
Aspiration Box - for duct mounting non-plenum rated CO <sub>2</sub> sensors ( <b>77N39</b> )		<b>90N43</b>	X	X	X	X
<b>Needlepoint Bipolar Ionization (NPBI)</b>						
Needlepoint Bipolar Ionization (NPBI) Kit		<b>22U15</b>	X	X	X	X
<b>UVC Germicidal Lamps</b>						
<sup>1</sup> Healthy Climate® UVC Light Kit (110/230v-1ph)		<b>21A93</b>	X	X	X	X
Step-Down Transformers	460V primary, 230V secondary	<b>10H20</b>	X	X	X	X
	575V primary, 230V secondary	<b>10H21</b>	X	X	X	X
<b>ELECTRICAL</b>						
Voltage 60 Hz	208/230V - 3 phase	Factory	O	O	O	O
	460V - 3 phase	Factory	O	O	O	O
	575V - 3 phase	Factory	O	O	O	O
HACR Circuit Breakers		Factory	O	O	O	O
<sup>2</sup> Short-Circuit Current Rating (SCCR) of 100kA (includes Phase/Voltage Detection)		Factory	O	O	O	O
Disconnect Switch	80 amp	<b>54W56</b>	OX	OX	OX	OX
GFI Service Outlets	15 amp non-powered, field-wired (208/230V, 460V only)	<b>74M70</b>	OX	OX	OX	OX
	15 amp factory-wired and powered (208/230V, 460V only)	Factory	O	O	O	O
	<sup>3</sup> 20 amp non-powered, field-wired (208/230V, 460V, 575V)	<b>67E01</b>	X	X	X	X
	<sup>3</sup> 20 amp non-powered, field-wired (575V)	Factory	O	O	O	O
Weatherproof Cover for GFI		<b>10C89</b>	X	X	X	X

<sup>1</sup> Lamps operate on 110-230V single-phase power supply. Step-down transformer may be ordered separately for 460V and 575V units. Alternately, 110V power supply may be used to directly power the UVC ballast(s).

<sup>2</sup> Disconnect Switch is furnished and factory installed with High SCCR option.

<sup>3</sup> Canada requires a minimum 20 amp circuit. Select 20 amp, non-powered, field wired GFI.

NOTE - Catalog and model numbers shown are for ordering field installed accessories.

OX - Configure To Order (Factory Installed) or Field Installed

O = Configure To Order (Factory Installed)

X = Field Installed

## OPTIONS / ACCESSORIES

Item Description	Catalog Number	Unit Model No				
		092	102	120	150	
<b>ECONOMIZER</b>						
<b>High Performance Economizer (Approved for California Title 24 Building Standards / AMCA Class 1A Certified)</b>						
High Performance Economizer (Downflow or Horizontal)	20U80	OX	OX	OX	OX	
Includes Economizer Dampers with Outdoor Air Hood and Barometric Relief Dampers with Exhaust Hood						
Downflow Applications - Use furnished Outdoor Air Hood and Barometric Relief Dampers with Exhaust Hood						
Horizontal Applications - Use furnished Outdoor Air Hood and Barometric Relief Dampers with Exhaust Hood - Order Horizontal Discharge Kit separately						
Horizontal Applications (reduced height) - Order Horizontal Low Profile Barometric Relief Dampers with Exhaust Hood and Horizontal Discharge Kit ( <b>51W25</b> ) separately						
<b>Horizontal Low Profile Barometric Relief Dampers</b>						
Horizontal Low Profile Barometric With Exhaust Hood	53K04	X	X	X	X	
<b>Economizer Controls</b>						
Differential Enthalpy (Not for Title 24)	Order 2 21Z09	OX	OX	OX	OX	
Sensible Control	Sensor is Furnished Factory	O	O	O	O	
Single Enthalpy	21Z09	OX	OX	OX	OX	
Building Pressure Control	13J77	X	X	X	X	
Outdoor Air CFM Control	13J76	X	X	X	X	
Global Control	Sensor Field Provided Factory	O	O	O	O	
<b>OUTDOOR AIR</b>						
<b>Outdoor Air Dampers With Outdoor Air Hood</b>						
Motorized	14G28	OX	OX	OX	OX	
Manual	14G29	X	X	X	X	
<b>POWER EXHAUST</b>						
Standard Static	208/230V-3ph	53W44	OX	OX	OX	OX
	460V-3ph	53W45	OX	OX	OX	OX
	575V-3ph	53W46	OX	OX	OX	OX
<b>HUMIDITROL® CONDENSER REHEAT OPTION</b>						
Humiditrol Dehumidification Option	Factory	O	O	O	O	
Humidity Sensor Kit, Remote mounted (required)	17M50	X	X	X	X	
<b>ROOF CURBS</b>						
<b>Hybrid Roof Curbs, Downflow</b>						
8 in. height	11F54	X	X	X	X	
14 in. height	11F55	X	X	X	X	
18 in. height	11F56	X	X	X	X	
24 in. height	11F57	X	X	X	X	
<b>Adjustable Pitch Curb, Downflow</b>						
14 in. height	54W50	X	X	X	X	
<b>CEILING DIFFUSERS</b>						
Step-Down - Order one	RTD11-95S	13K61	X			
	RTD11-135S	13K62		X	X	
	RTD11-185S	13K63			X	
Flush - Order one	FD11-95S	13K56	X			
	FD11-135S	13K57		X	X	
	FD11-185S	13K58			X	
Transitions (Supply and Return) - Order one	C1DIFF30B-1	12X65	X			
	C1DIFF31B-1	12X66		X	X	
	C1DIFF32B-1	12X67			X	

NOTE - Catalog and model numbers shown are for ordering field installed accessories.

OX - Configure To Order (Factory Installed) or Field Installed

O = Configure To Order (Factory Installed)

X = Field Installed

SPECIFICATIONS			MSAV MODELS			
General Data		Nominal Tonnage	7.5 Ton	8.5 Ton	10 Ton	12.5 Ton
		Efficiency Type	High	High	High	High
		Model Number	LGT092H4E	LGT102H4E	LGT120H4E	LGT150H4E
		Blower Type	DirectPlus™ ECM Direct Drive with MSAV®	DirectPlus™ ECM Direct Drive with MSAV®	DirectPlus™ ECM Direct Drive with MSAV®	DirectPlus™ ECM Direct Drive with MSAV®
<b>Cooling Performance</b>	Gross Cooling Capacity - Btuh		93,000	101,000	117,000	141,000
	<sup>1</sup> Net Cooling Capacity - Btuh		90,000	98,000	114,000	136,000
	<sup>1</sup> AHRI Rated Air Flow - cfm		3000	3400	3400	4100
	Total Unit Power - kW		7.5	8.1	9.5	12.5
	<sup>1</sup> IEER (Btuh/Watt)		15.7	15.7	15.5	14.6
	<sup>1</sup> EER (Btuh/Watt)		12.3	12.1	12.1	10.8
<b>Refrigerant Charge</b>	Refrigerant Type		R-410A	R-410A	R-410A	R-410A
	Without Reheat Option	Circuit 1	7 lbs. 0 oz.	7 lbs. 0 oz.	7 lbs. 0 oz.	7 lbs. 4 oz.
		Circuit 2	7 lbs. 0 oz.	7 lbs. 6 oz.	7 lbs. 0 oz.	7 lbs. 0 oz.
	With Reheat Option	Circuit 1	7 lbs. 4 oz.	7 lbs. 4 oz.	7 lbs. 4 oz.	7 lbs. 8 oz.
Circuit 2		7 lbs. 0 oz.	7 lbs. 6 oz.	7 lbs. 0 oz.	7 lbs. 0 oz.	
<b>Gas Heating Options Available</b>			See page 25			
<b>Compressor Type (number)</b>			Two-Stage Scroll (1) Single-Stage Scroll (1)			
<b>Outdoor Coils</b>	Net face area (total) - sq. ft.		28.0	28.0	28.0	28.0
	Number of rows		1	1	1	1
	Fins per inch		23	23	23	23
<b>Outdoor Coil Fans</b>	Motor - (No.) HP		2 (1/3)	2 (1/3)	2 (1/2)	2 (1/2)
	Motor rpm		1075	1075	1075	1075
	Total Motor watts		860	860	1000	1000
	Diameter - (No.) in.		(2) 24	(2) 24	(2) 24	(2) 24
	Number of blades		3	3	3	3
	Total Air volume - cfm		9000	9000	9700	9700
<b>Indoor Coil</b>	Net face area (total) - sq. ft.		12.78	12.78	12.78	12.78
	Tube diameter - in.		3/8	3/8	3/8	3/8
	Number of rows		4	4	4	4
	Fins per inch		14	14	14	14
	Drain connection - Number and size		(1) 1 in. NPT coupling			
Expansion device type		Balanced Port Thermostatic Expansion Valve (removable element head)				
<b>Indoor Blower</b>	Nominal motor output		3.75 HP (ECM)	3.75 HP (ECM)	3.75 HP (ECM)	3.75 HP (ECM)
	Blower wheel nominal diameter x width - in.		(1) 22 x 9	(1) 22 x 9	(1) 22 x 9	(1) 22 x 9
<b>Filters</b>	Type of filter		MERV 4, Disposable			
	Number and size - in.		(4) 20 x 25 x 2			
<b>Electrical characteristics</b>			208/230V, 460V, or 575V - 60 Hz -3 phase			

NOTE - Net capacity includes evaporator blower motor heat deduction. Gross capacity does not include evaporator blower motor heat deduction.

<sup>1</sup> AHRI Certified to AHRI Standard 340/360; 95°F outdoor air temperature and 80°F db/67°F wb entering evaporator air; minimum external duct static pressure.

SPECIFICATIONS			VAV MODELS			
General Data		Nominal Tonnage	7.5 Ton	8.5 Ton	10 Ton	12.5 Ton
		Efficiency Type	High	High	High	High
		Model Number	LGT092H4P	LGT102H4P	LGT120H4P	LGT150H4P
		Blower Type	DirectPlus™ ECM Direct Drive with VAV	DirectPlus™ ECM Direct Drive with VAV	DirectPlus™ ECM Direct Drive with VAV	DirectPlus™ ECM Direct Drive with VAV
<b>Cooling Performance</b>	Gross Cooling Capacity - Btuh		93,000	101,000	117,000	141,000
	<sup>1</sup> Net Cooling Capacity - Btuh		90,000	98,000	114,000	136,000
	<sup>1</sup> AHRI Rated Air Flow - cfm		3000	3400	3400	4100
	Total Unit Power - kW		7.5	8.1	9.5	12.5
	<sup>1</sup> IEER (Btuh/Watt)		14.6	14.6	14.6	14.0
	<sup>1</sup> EER (Btuh/Watt)		12.3	12.1	12.1	10.8
<b>Refrigerant Charge</b>	Refrigerant Type		R-410A	R-410A	R-410A	R-410A
	Without Reheat Option	Circuit 1	7 lbs. 0 oz.	7 lbs. 0 oz.	7 lbs. 0 oz.	7 lbs. 4 oz.
		Circuit 2	7 lbs. 0 oz.	7 lbs. 6 oz.	7 lbs. 0 oz.	7 lbs. 0 oz.
<b>Gas Heating Options Available</b>			See page 25			
<b>Compressor Type (number)</b>			Two-Stage Scroll (1) Single-Stage Scroll (1)			
<b>Outdoor Coils</b>	Net face area (total) - sq. ft.		28.0	28.0	28.0	28.0
	Number of rows		1	1	1	1
	Fins per inch		23	23	23	23
<b>Outdoor Coil Fans</b>	Motor - (No.) HP		2 (1/3)	2 (1/3)	2 (1/2)	2 (1/2)
	Motor rpm		1075	1075	1075	1075
	Total Motor watts		860	860	1000	1000
	Diameter - (No.) in.		(2) 24	(2) 24	(2) 24	(2) 24
	Number of blades		3	3	3	3
	Total Air volume - cfm		9000	9000	9700	9700
	<b>Indoor Coil</b>	Net face area (total) - sq. ft.		12.78	12.78	12.78
Tube diameter - in.		3/8	3/8	3/8	3/8	
Number of rows		4	4	4	4	
Fins per inch		14	14	14	14	
Drain connection - Number and size		(1) 1 in. NPT coupling				
Expansion device type		Balanced Port Thermostatic Expansion Valve (removable element head)				
<b>Indoor Blower</b>	Nominal motor output		3.75 HP (ECM)	3.75 HP (ECM)	3.75 HP (ECM)	3.75 HP (ECM)
	Blower wheel nominal diameter x width - in.		(1) 22 x 9	(1) 22 x 9	(1) 22 x 9	(1) 22 x 9
<b>Filters</b>	Type of filter		Disposable			
	Number and size - in.		(4) 20 x 25 x 2			
<b>Electrical characteristics</b>			208/230V, 460V, or 575V - 60 Hz -3 phase			

NOTE - Net capacity includes evaporator blower motor heat deduction. Gross capacity does not include evaporator blower motor heat deduction.

<sup>1</sup> AHRI Certified to AHRI Standard 340/360; 95°F outdoor air temperature and 80°F db/67°F wb entering evaporator air; minimum external duct static pressure.



SPECIFICATIONS			GAS HEAT		
		Heat Input Type	Standard	Medium	High
		Number of Gas Heat Stages	2	2	2
Gas Heating Performance	Input - Btuh	First Stage	85,000	117,000	156,000
		Second Stage	130,000	180,000	240,000
	Output - Btuh	Second Stage	105,000	146,000	194,000
		Temperature Rise Range - °F	15 - 45	30 - 60	40 - 70
		Minimum Air Volume - cfm	2150	2250	2600
		Thermal Efficiency	81%	81%	81%
		Gas Supply Connections	3/4 in. NPT	3/4 in. NPT	3/4 in. NPT.
Recommended Gas Supply Pressure - Nat. / LPG			7 in. w.g. / 11 in. w.g.		
Gas Supply Pressure Range	Min./Max. (Natural)		4.7 - 10.5 in. w.g.		
	Min./Max. (LPG)		10.8 - 13.5 in. w.g.		

### HIGH ALTITUDE DERATE

**NOTE** - Units may be installed at altitudes up to 2000 feet above sea level without any modifications.

At altitudes above 2000 feet units must be derated to match gas manifold pressures shown in table below.

At altitudes above 4500 feet unit must be derated 4% for each 1000 feet above sea level.

**NOTE** - This is the only permissible derate for these units.

Refer to the Installation Instructions for more detailed information.

Heat Input Type	Altitude Feet	Gas Manifold Pressure in. w.g.		Input Rate (Btuh)
		Natural Gas	LPG/ Propane	
Standard (2 stage)	2001 - 4500	1.6 / 3.1	4.4 / 8.9	84,500 / 120,000
Medium (2 stage)	2001 - 4500	1.6 / 3.1	4.4 / 8.9	117,000 / 166,000
High (2 stage)	2001 - 4500	1.6 / 3.1	4.4 / 8.9	156,000 / 221,000

# RATINGS

NOTE – For Temperatures and Capacities not shown in tables, see bulletin – Cooling Unit Rating Table Correction Factor Data in Miscellaneous Engineering Data section.

## 7.5 TON - LGT092H4E/P (1 COMPRESSOR - PART LOAD)

Entering Wet Bulb Temperature	Total Air Volume	Outdoor Air Temperature Entering Outdoor Coil																			
		65°F					75°F					85°F					95°F				
		Total Cool Cap.	Comp. Motor Input	Sensible To Total Ratio (S/T)			Total Cool Cap.	Comp. Motor Input	Sensible To Total Ratio (S/T)			Total Cool Cap.	Comp. Motor Input	Sensible To Total Ratio (S/T)			Total Cool Cap.	Comp. Motor Input	Sensible To Total Ratio (S/T)		
				Dry Bulb					Dry Bulb					Dry Bulb					Dry Bulb		
cfm	kBtuh	kW	75°F	80°F	85°F	kBtuh	kW	75°F	80°F	85°F	kBtuh	kW	75°F	80°F	85°F	kBtuh	kW	75°F	80°F	85°F	
63°F	1440	38.7	1.17	.79	.97	1.00	36.5	1.44	.80	.99	1.00	34.0	1.73	.82	1.00	1.00	31.3	2.03	.84	1.00	1.00
	1800	41.3	1.16	.85	1.00	1.00	39.2	1.43	.87	1.00	1.00	36.6	1.72	.89	1.00	1.00	33.8	2.02	.93	1.00	1.00
	2160	43.5	1.15	.92	1.00	1.00	41.3	1.43	.95	1.00	1.00	38.6	1.71	.98	1.00	1.00	35.7	2.01	1.00	1.00	1.00
67°F	1440	40.7	1.16	.62	.77	.93	38.4	1.44	.62	.78	.95	35.8	1.72	.62	.80	.98	32.8	2.03	.62	.82	1.00
	1800	42.9	1.15	.66	.84	1.00	40.5	1.43	.66	.85	1.00	37.6	1.71	.67	.87	1.00	34.5	2.02	.68	.90	1.00
	2160	44.4	1.15	.70	.90	1.00	41.9	1.42	.71	.92	1.00	39.1	1.71	.71	.95	1.00	35.9	2.02	.73	.99	1.00
71°F	1440	43.1	1.15	.46	.61	.76	40.8	1.43	.45	.61	.76	38.0	1.71	.43	.61	.78	35.0	2.02	.43	.62	.80
	1800	45.3	1.15	.47	.65	.82	42.7	1.42	.47	.66	.83	39.9	1.71	.46	.66	.85	36.6	2.01	.45	.68	.88
	2160	46.5	1.14	.49	.69	.88	44.1	1.42	.49	.70	.90	41.1	1.71	.48	.71	.93	37.7	2.01	.48	.73	.97

## 7.5 TON - LGT092H4E/P (2 COMPRESSORS - PART LOAD / FULL LOAD)

Entering Wet Bulb Temperature	Total Air Volume	Outdoor Air Temperature Entering Outdoor Coil																			
		85°F					95°F					105°F					115°F				
		Total Cool Cap.	Comp. Motor Input	Sensible To Total Ratio (S/T)			Total Cool Cap.	Comp. Motor Input	Sensible To Total Ratio (S/T)			Total Cool Cap.	Comp. Motor Input	Sensible To Total Ratio (S/T)			Total Cool Cap.	Comp. Motor Input	Sensible To Total Ratio (S/T)		
				Dry Bulb					Dry Bulb					Dry Bulb					Dry Bulb		
cfm	kBtuh	kW	75°F	80°F	85°F	kBtuh	kW	75°F	80°F	85°F	kBtuh	kW	75°F	80°F	85°F	kBtuh	kW	75°F	80°F	85°F	
63°F	1920	73.0	4.33	.66	.81	.91	67.3	4.96	.68	.81	.93	61.4	5.68	.68	.83	.95	55.1	6.50	.68	.85	.99
	2400	78.4	4.32	.72	.86	.98	72.7	4.95	.73	.88	1.00	66.4	5.66	.75	.90	1.00	59.8	6.49	.76	.93	1.00
	2880	83.0	4.31	.77	.91	1.00	76.9	4.94	.78	.93	1.00	70.2	5.65	.81	.97	1.00	63.4	6.47	.83	1.00	1.00
67°F	1920	78.3	4.31	.52	.64	.77	72.2	4.95	.51	.65	.79	65.8	5.65	.51	.65	.80	59.1	6.48	.50	.66	.82
	2400	83.1	4.30	.55	.69	.83	76.7	4.93	.54	.71	.85	69.9	5.64	.55	.72	.87	62.7	6.47	.55	.75	.90
	2880	86.5	4.29	.58	.75	.89	79.9	4.92	.59	.77	.91	72.9	5.64	.58	.80	.93	65.5	6.46	.60	.81	.97
71°F	1920	84.1	4.30	.39	.51	.62	78.0	4.93	.37	.50	.63	71.3	5.64	.35	.49	.64	64.2	6.46	.34	.49	.65
	2400	89.1	4.29	.41	.54	.67	82.5	4.92	.39	.54	.68	75.4	5.63	.37	.55	.71	67.9	6.45	.36	.55	.72
	2880	92.7	4.29	.42	.58	.73	85.7	4.92	.41	.59	.75	78.4	5.63	.40	.58	.76	70.6	6.44	.39	.59	.80

## 7.5 TON - LGT092H4E/P (2 COMPRESSORS - FULL LOAD)

Entering Wet Bulb Temperature	Total Air Volume	Outdoor Air Temperature Entering Outdoor Coil																			
		85°F					95°F					105°F					115°F				
		Total Cool Cap.	Comp. Motor Input	Sensible To Total Ratio (S/T)			Total Cool Cap.	Comp. Motor Input	Sensible To Total Ratio (S/T)			Total Cool Cap.	Comp. Motor Input	Sensible To Total Ratio (S/T)			Total Cool Cap.	Comp. Motor Input	Sensible To Total Ratio (S/T)		
				Dry Bulb					Dry Bulb					Dry Bulb					Dry Bulb		
cfm	kBtuh	kW	75°F	80°F	85°F	kBtuh	kW	75°F	80°F	85°F	kBtuh	kW	75°F	80°F	85°F	kBtuh	kW	75°F	80°F	85°F	
63°F	2400	91.5	5.16	.68	.80	.91	85.6	5.81	.68	.81	.93	79.3	6.56	.70	.83	.95	72.6	7.44	.70	.84	.98
	3000	97.6	5.19	.73	.86	.98	91.3	5.84	.74	.88	1.00	84.8	6.59	.75	.90	1.00	77.8	7.46	.77	.92	1.00
	3600	102.5	5.21	.78	.92	1.00	96.0	5.86	.79	.94	1.00	88.9	6.60	.81	.96	1.00	81.5	7.47	.83	.99	1.00
67°F	2400	96.7	5.19	.53	.65	.77	90.1	5.83	.52	.66	.78	83.4	6.58	.53	.67	.80	76.2	7.45	.52	.69	.82
	3000	102.0	5.21	.56	.71	.83	95.1	5.86	.56	.72	.85	88.0	6.61	.57	.73	.87	80.6	7.47	.56	.74	.89
	3600	105.9	5.23	.60	.76	.89	99.0	5.88	.60	.77	.91	91.9	6.62	.61	.78	.93	84.1	7.48	.62	.80	.96
71°F	2400	103.3	5.22	.40	.51	.63	96.5	5.87	.39	.52	.64	89.4	6.61	.37	.52	.65	81.9	7.48	.35	.51	.66
	3000	108.7	5.25	.41	.55	.69	101.3	5.89	.40	.56	.70	93.8	6.63	.38	.56	.72	85.7	7.50	.38	.57	.73
	3600	112.4	5.27	.42	.60	.74	104.9	5.91	.41	.59	.76	97.0	6.65	.41	.60	.77	88.7	7.51	.41	.61	.79

# RATINGS

NOTE – For Temperatures and Capacities not shown in tables, see bulletin – Cooling Unit Rating Table Correction Factor Data in Miscellaneous Engineering Data section.

## 8.5 TON - LGT102H4E/P (1 COMPRESSOR - PART LOAD)

Entering Wet Bulb Temperature	Total Air Volume	Outdoor Air Temperature Entering Outdoor Coil																			
		65°F					75°F					85°F					95°F				
		Total Cool Cap.	Comp. Motor Input	Sensible To Total Ratio (S/T)			Total Cool Cap.	Comp. Motor Input	Sensible To Total Ratio (S/T)			Total Cool Cap.	Comp. Motor Input	Sensible To Total Ratio (S/T)			Total Cool Cap.	Comp. Motor Input	Sensible To Total Ratio (S/T)		
				Dry Bulb					Dry Bulb					Dry Bulb					Dry Bulb		
cfm	kBtuh	kW	75°F	80°F	85°F	kBtuh	kW	75°F	80°F	85°F	kBtuh	kW	75°F	80°F	85°F	kBtuh	kW	75°F	80°F	85°F	
63°F	1600	39.8	1.16	.82	1.00	1.00	37.7	1.44	.83	1.00	1.00	35.3	1.72	.85	1.00	1.00	32.6	2.03	.88	1.00	1.00
	2000	42.6	1.15	.89	1.00	1.00	40.4	1.43	.91	1.00	1.00	37.8	1.71	.94	1.00	1.00	34.9	2.02	.98	1.00	1.00
	2400	44.8	1.15	.96	1.00	1.00	42.4	1.42	.99	1.00	1.00	39.8	1.71	1.00	1.00	1.00	36.8	2.01	1.00	1.00	1.00
67°F	1600	41.8	1.16	.64	.80	.97	39.4	1.43	.64	.81	.99	36.6	1.72	.64	.83	1.00	33.6	2.02	.65	.86	1.00
	2000	43.8	1.15	.68	.87	1.00	41.3	1.43	.69	.89	1.00	38.5	1.71	.69	.91	1.00	35.3	2.02	.71	.94	1.00
	2400	45.3	1.15	.72	.94	1.00	42.8	1.42	.73	.96	1.00	39.9	1.71	.74	.99	1.00	36.8	2.01	.76	1.00	1.00
71°F	1600	44.2	1.15	.46	.63	.78	41.7	1.43	.46	.63	.79	39.0	1.71	.45	.64	.81	35.8	2.02	.44	.64	.83
	2000	46.1	1.15	.49	.68	.85	43.5	1.42	.48	.68	.87	40.6	1.71	.47	.69	.89	37.2	2.01	.47	.71	.92
	2400	47.4	1.14	.51	.72	.92	44.8	1.42	.50	.73	.94	41.8	1.71	.50	.74	.98	38.5	2.01	.50	.76	1.00

## 8.5 TON - LGT102H4E/P (2 COMPRESSORS - PART LOAD / FULL LOAD)

Entering Wet Bulb Temperature	Total Air Volume	Outdoor Air Temperature Entering Outdoor Coil																			
		85°F					95°F					105°F					115°F				
		Total Cool Cap.	Comp. Motor Input	Sensible To Total Ratio (S/T)			Total Cool Cap.	Comp. Motor Input	Sensible To Total Ratio (S/T)			Total Cool Cap.	Comp. Motor Input	Sensible To Total Ratio (S/T)			Total Cool Cap.	Comp. Motor Input	Sensible To Total Ratio (S/T)		
				Dry Bulb					Dry Bulb					Dry Bulb					Dry Bulb		
cfm	kBtuh	kW	75°F	80°F	85°F	kBtuh	kW	75°F	80°F	85°F	kBtuh	kW	75°F	80°F	85°F	kBtuh	kW	75°F	80°F	85°F	
63°F	2160	78.1	4.52	.68	.82	.93	72.2	5.18	.70	.84	.95	66.1	5.93	.70	.86	.98	59.6	6.78	.71	.88	1.00
	2700	83.8	4.51	.74	.88	1.00	77.8	5.18	.76	.90	1.00	71.3	5.92	.77	.93	1.00	64.4	6.77	.80	.96	1.00
	3240	88.4	4.51	.80	.94	1.00	82.0	5.17	.81	.96	1.00	75.3	5.92	.84	.99	1.00	68.3	6.76	.86	1.00	1.00
67°F	2160	83.6	4.51	.53	.66	.79	77.2	5.17	.52	.67	.81	70.6	5.92	.52	.68	.83	63.5	6.76	.52	.69	.85
	2700	88.4	4.50	.56	.72	.86	81.8	5.16	.55	.73	.87	74.7	5.91	.57	.75	.90	67.3	6.75	.56	.77	.93
	3240	91.9	4.50	.59	.77	.91	85.2	5.17	.60	.79	.93	77.8	5.91	.61	.81	.96	70.0	6.74	.62	.84	1.00
71°F	2160	89.8	4.50	.39	.52	.64	83.3	5.16	.38	.51	.65	76.3	5.90	.37	.51	.65	68.9	6.74	.36	.51	.67
	2700	94.8	4.50	.40	.55	.69	87.9	5.16	.40	.56	.71	80.4	5.90	.39	.56	.73	72.5	6.74	.37	.56	.74
	3240	98.3	4.50	.42	.59	.75	91.0	5.16	.42	.60	.77	83.5	5.90	.41	.60	.79	75.1	6.73	.40	.62	.82

## 8.5 TON - LGT102H4E/P (2 COMPRESSORS - FULL LOAD)

Entering Wet Bulb Temperature	Total Air Volume	Outdoor Air Temperature Entering Outdoor Coil																			
		85°F					95°F					105°F					115°F				
		Total Cool Cap.	Comp. Motor Input	Sensible To Total Ratio (S/T)			Total Cool Cap.	Comp. Motor Input	Sensible To Total Ratio (S/T)			Total Cool Cap.	Comp. Motor Input	Sensible To Total Ratio (S/T)			Total Cool Cap.	Comp. Motor Input	Sensible To Total Ratio (S/T)		
				Dry Bulb					Dry Bulb					Dry Bulb					Dry Bulb		
cfm	kBtuh	kW	75°F	80°F	85°F	kBtuh	kW	75°F	80°F	85°F	kBtuh	kW	75°F	80°F	85°F	kBtuh	kW	75°F	80°F	85°F	
63°F	2720	97.5	5.37	.70	.83	.94	91.2	6.05	.70	.84	.96	84.6	6.83	.72	.85	.98	77.8	7.73	.73	.87	1.00
	3400	103.8	5.41	.75	.89	1.00	97.3	6.09	.77	.90	1.00	90.4	6.87	.78	.93	1.00	82.9	7.75	.80	.96	1.00
	4080	108.7	5.44	.81	.95	1.00	101.9	6.12	.82	.97	1.00	94.5	6.89	.84	.99	1.00	86.9	7.78	.85	1.00	1.00
67°F	2720	102.8	5.40	.54	.67	.80	95.8	6.08	.54	.69	.81	88.7	6.86	.54	.70	.83	81.2	7.75	.54	.71	.85
	3400	107.9	5.43	.57	.74	.86	100.8	6.11	.58	.75	.88	93.3	6.88	.59	.76	.90	85.7	7.77	.60	.77	.92
	4080	111.9	5.46	.61	.78	.92	104.8	6.14	.61	.80	.94	97.2	6.91	.62	.81	.97	89.1	7.79	.64	.83	.99
71°F	2720	109.7	5.44	.39	.53	.66	102.5	6.12	.40	.53	.66	95.0	6.89	.38	.54	.68	87.0	7.78	.36	.53	.69
	3400	114.9	5.48	.42	.57	.72	107.3	6.15	.41	.57	.72	99.3	6.92	.39	.58	.74	90.8	7.80	.39	.59	.76
	4080	118.6	5.50	.44	.61	.77	110.7	6.18	.42	.62	.78	102.4	6.94	.42	.63	.80	93.7	7.82	.42	.63	.82

# RATINGS

NOTE – For Temperatures and Capacities not shown in tables, see bulletin – Cooling Unit Rating Table Correction Factor Data in Miscellaneous Engineering Data section.

## 10 TON - LGT120H4E/P (1 COMPRESSOR - PART LOAD)

Entering Wet Bulb Temperature	Total Air Volume	Outdoor Air Temperature Entering Outdoor Coil																			
		65°F					75°F					85°F					95°F				
		Total Cool Cap.	Comp. Motor Input	Sensible To Total Ratio (S/T)			Total Cool Cap.	Comp. Motor Input	Sensible To Total Ratio (S/T)			Total Cool Cap.	Comp. Motor Input	Sensible To Total Ratio (S/T)			Total Cool Cap.	Comp. Motor Input	Sensible To Total Ratio (S/T)		
				Dry Bulb					Dry Bulb					Dry Bulb					Dry Bulb		
cfm	kBtuh	kW	75°F	80°F	85°F	kBtuh	kW	75°F	80°F	85°F	kBtuh	kW	75°F	80°F	85°F	kBtuh	kW	75°F	80°F	85°F	
63°F	1920	49.3	1.64	.78	.98	1.00	46.8	1.89	.80	1.00	1.00	44.3	2.18	.81	1.00	1.00	41.6	2.50	.83	1.00	1.00
	2400	52.5	1.61	.84	1.00	1.00	50.1	1.86	.86	1.00	1.00	47.4	2.15	.88	1.00	1.00	44.5	2.47	.93	1.00	1.00
	2880	55.2	1.59	.91	1.00	1.00	52.5	1.84	.95	1.00	1.00	49.7	2.12	.99	1.00	1.00	46.6	2.44	1.00	1.00	1.00
67°F	1920	51.7	1.62	.61	.76	.92	49.1	1.87	.61	.77	.96	46.3	2.16	.62	.79	.99	43.2	2.48	.62	.81	1.00
	2400	54.3	1.60	.65	.82	1.00	51.5	1.85	.65	.84	1.00	48.4	2.13	.66	.86	1.00	45.3	2.46	.67	.89	1.00
	2880	56.2	1.58	.69	.88	1.00	53.2	1.83	.69	.92	1.00	50.2	2.11	.71	.96	1.00	46.8	2.44	.72	1.00	1.00
71°F	1920	54.8	1.59	.44	.60	.74	52.0	1.84	.44	.60	.75	49.1	2.13	.44	.61	.77	45.9	2.45	.44	.62	.79
	2400	57.3	1.57	.46	.64	.80	54.4	1.82	.46	.65	.82	51.3	2.10	.46	.66	.84	47.7	2.42	.46	.67	.87
	2880	59.1	1.55	.48	.68	.86	56.0	1.80	.48	.69	.88	52.7	2.08	.48	.70	.92	49.1	2.41	.48	.72	.97

## 10 TON - LGT120H4E/P (2 COMPRESSORS - PART LOAD / FULL LOAD)

Entering Wet Bulb Temperature	Total Air Volume	Outdoor Air Temperature Entering Outdoor Coil																			
		85°F					95°F					105°F					115°F				
		Total Cool Cap.	Comp. Motor Input	Sensible To Total Ratio (S/T)			Total Cool Cap.	Comp. Motor Input	Sensible To Total Ratio (S/T)			Total Cool Cap.	Comp. Motor Input	Sensible To Total Ratio (S/T)			Total Cool Cap.	Comp. Motor Input	Sensible To Total Ratio (S/T)		
				Dry Bulb					Dry Bulb					Dry Bulb					Dry Bulb		
cfm	kBtuh	kW	75°F	80°F	85°F	kBtuh	kW	75°F	80°F	85°F	kBtuh	kW	75°F	80°F	85°F	kBtuh	kW	75°F	80°F	85°F	
63°F	2560	96.5	5.75	.66	.82	.92	90.4	6.52	.67	.82	.94	84.2	7.41	.68	.84	.96	77.5	8.43	.70	.86	.99
	3200	102.9	5.75	.72	.87	.99	96.7	6.52	.74	.89	1.00	90.1	7.41	.76	.91	1.00	82.8	8.42	.77	.94	1.00
	3840	108.1	5.75	.77	.93	1.00	101.5	6.52	.79	.95	1.00	94.6	7.41	.82	.98	1.00	87.0	8.41	.84	1.00	1.00
67°F	2560	102.9	5.74	.52	.65	.78	96.3	6.51	.52	.65	.79	89.3	7.39	.53	.66	.81	81.8	8.39	.53	.67	.83
	3200	108.3	5.73	.55	.70	.84	101.3	6.50	.56	.70	.86	93.9	7.38	.56	.73	.88	86.1	8.39	.56	.76	.91
	3840	112.4	5.73	.58	.76	.90	105.2	6.49	.59	.76	.92	97.4	7.38	.60	.81	.95	89.1	8.38	.61	.82	.98
71°F	2560	109.9	5.73	.39	.51	.63	103.1	6.50	.39	.51	.63	95.9	7.38	.38	.51	.64	87.9	8.38	.37	.51	.66
	3200	115.6	5.73	.40	.54	.67	108.2	6.49	.40	.55	.69	100.5	7.36	.40	.55	.70	92.3	8.36	.39	.55	.72
	3840	119.7	5.72	.42	.57	.74	112.1	6.48	.42	.59	.74	104.0	7.35	.41	.58	.77	95.1	8.35	.42	.61	.80

## 10 TON - LGT120H4E/P (2 COMPRESSORS - FULL LOAD)

Entering Wet Bulb Temperature	Total Air Volume	Outdoor Air Temperature Entering Outdoor Coil																			
		85°F					95°F					105°F					115°F				
		Total Cool Cap.	Comp. Motor Input	Sensible To Total Ratio (S/T)			Total Cool Cap.	Comp. Motor Input	Sensible To Total Ratio (S/T)			Total Cool Cap.	Comp. Motor Input	Sensible To Total Ratio (S/T)			Total Cool Cap.	Comp. Motor Input	Sensible To Total Ratio (S/T)		
				Dry Bulb					Dry Bulb					Dry Bulb					Dry Bulb		
cfm	kBtuh	kW	75°F	80°F	85°F	kBtuh	kW	75°F	80°F	85°F	kBtuh	kW	75°F	80°F	85°F	kBtuh	kW	75°F	80°F	85°F	
63°F	3200	117.6	6.74	.68	.81	.92	110.9	7.58	.69	.82	.95	103.9	8.55	.71	.84	.97	96.1	9.65	.71	.86	1.00
	4000	124.6	6.79	.74	.87	1.00	117.5	7.64	.75	.89	1.00	110.0	8.61	.76	.92	1.00	101.9	9.72	.78	.95	1.00
	4800	130.3	6.85	.78	.93	1.00	122.8	7.69	.80	.96	1.00	114.8	8.65	.82	.99	1.00	106.2	9.77	.84	1.00	1.00
67°F	3200	123.7	6.79	.53	.66	.78	116.2	7.62	.54	.66	.79	108.5	8.59	.54	.68	.81	100.2	9.70	.54	.70	.83
	4000	129.6	6.84	.57	.71	.84	121.9	7.68	.56	.73	.86	113.7	8.64	.58	.74	.88	105.1	9.75	.59	.76	.91
	4800	134.2	6.88	.61	.76	.90	126.2	7.73	.61	.78	.93	117.9	8.69	.61	.79	.96	109.0	9.80	.62	.82	.99
71°F	3200	131.6	6.86	.39	.52	.63	123.8	7.70	.39	.52	.65	115.6	8.66	.39	.53	.66	106.8	9.77	.38	.53	.67
	4000	137.6	6.92	.41	.55	.69	129.2	7.76	.41	.56	.71	120.4	8.72	.40	.57	.73	111.2	9.83	.40	.58	.74
	4800	141.9	6.96	.43	.59	.74	133.0	7.80	.41	.60	.76	123.8	8.76	.42	.62	.78	114.3	9.86	.42	.61	.80

# RATINGS

NOTE – For Temperatures and Capacities not shown in tables, see bulletin – Cooling Unit Rating Table Correction Factor Data in Miscellaneous Engineering Data section.

## 12.5 TON - LGT150H4E/P (1 COMPRESSOR - PART LOAD)

Entering Wet Bulb Temperature	Total Air Volume	Outdoor Air Temperature Entering Outdoor Coil																			
		65°F					75°F					85°F					95°F				
		Total Cool Cap.	Comp. Motor Input	Sensible To Total Ratio (S/T)			Total Cool Cap.	Comp. Motor Input	Sensible To Total Ratio (S/T)			Total Cool Cap.	Comp. Motor Input	Sensible To Total Ratio (S/T)			Total Cool Cap.	Comp. Motor Input	Sensible To Total Ratio (S/T)		
				Dry Bulb					Dry Bulb					Dry Bulb					Dry Bulb		
		cfm	kBtuh	kW	75°F	80°F	85°F	kBtuh	kW	75°F	80°F	85°F	kBtuh	kW	75°F	80°F	85°F	kBtuh	kW	75°F	80°F
63°F	2080	56.0	2.12	.76	.93	1.00	53.2	2.45	.77	.96	1.00	50.2	2.82	.79	.99	1.00	47.0	3.25	.80	1.00	1.00
	2600	59.2	2.11	.81	1.00	1.00	56.5	2.44	.83	1.00	1.00	53.5	2.81	.85	1.00	1.00	50.3	3.24	.89	1.00	1.00
	3120	62.3	2.10	.87	1.00	1.00	59.3	2.43	.90	1.00	1.00	56.2	2.80	.94	1.00	1.00	52.8	3.23	.98	1.00	1.00
67°F	2080	58.9	2.11	.59	.74	.88	55.9	2.44	.59	.75	.91	52.8	2.82	.60	.76	.95	49.2	3.24	.61	.78	.99
	2600	61.8	2.10	.63	.79	.99	58.7	2.43	.63	.81	1.00	55.3	2.81	.64	.83	1.00	51.5	3.23	.65	.86	1.00
	3120	64.1	2.09	.66	.84	1.00	60.7	2.42	.67	.87	1.00	57.1	2.80	.68	.91	1.00	53.3	3.23	.70	.95	1.00
71°F	2080	62.3	2.10	.44	.58	.72	59.3	2.43	.44	.59	.73	55.9	2.80	.43	.59	.74	52.3	3.23	.43	.60	.76
	2600	65.5	2.09	.45	.62	.77	62.1	2.42	.45	.63	.79	58.5	2.79	.45	.64	.81	54.7	3.22	.45	.65	.83
	3120	67.7	2.08	.47	.65	.82	64.1	2.41	.47	.66	.84	60.4	2.78	.47	.68	.87	56.3	3.21	.47	.69	.92

## 12.5 TON - LGT150H4E/P (2 COMPRESSORS - PART LOAD / FULL LOAD)

Entering Wet Bulb Temperature	Total Air Volume	Outdoor Air Temperature Entering Outdoor Coil																			
		85°F					95°F					105°F					115°F				
		Total Cool Cap.	Comp. Motor Input	Sensible To Total Ratio (S/T)			Total Cool Cap.	Comp. Motor Input	Sensible To Total Ratio (S/T)			Total Cool Cap.	Comp. Motor Input	Sensible To Total Ratio (S/T)			Total Cool Cap.	Comp. Motor Input	Sensible To Total Ratio (S/T)		
				Dry Bulb					Dry Bulb					Dry Bulb					Dry Bulb		
		cfm	kBtuh	kW	75°F	80°F	85°F	kBtuh	kW	75°F	80°F	85°F	kBtuh	kW	75°F	80°F	85°F	kBtuh	kW	75°F	80°F
63°F	3200	117.3	7.63	.68	.83	.93	110.0	8.65	.68	.84	.96	102.4	9.81	.71	.86	.99	94.2	11.13	.72	.88	1.00
	4000	124.5	7.68	.73	.88	1.00	117.1	8.71	.74	.90	1.00	109.1	9.87	.77	.93	1.00	100.4	11.19	.80	.97	1.00
	4800	130.6	7.72	.79	.94	1.00	122.7	8.75	.81	.97	1.00	114.3	9.91	.84	.99	1.00	105.4	11.23	.87	1.00	1.00
67°F	3200	125.0	7.67	.53	.65	.78	117.0	8.69	.54	.67	.80	108.6	9.85	.54	.68	.83	99.4	11.16	.54	.70	.85
	4000	131.1	7.70	.57	.71	.85	122.7	8.73	.56	.72	.87	113.6	9.88	.57	.76	.90	104.1	11.19	.59	.78	.93
	4800	135.6	7.73	.59	.76	.91	127.0	8.76	.60	.78	.93	117.7	9.91	.60	.81	.97	107.8	11.22	.63	.84	1.00
71°F	3200	133.3	7.72	.39	.52	.63	124.9	8.74	.40	.52	.64	116.1	9.90	.39	.53	.65	106.7	11.22	.39	.53	.67
	4000	139.8	7.75	.41	.55	.69	131.0	8.78	.40	.55	.70	121.6	9.94	.41	.57	.73	111.3	11.25	.41	.58	.76
	4800	144.5	7.78	.43	.58	.73	135.2	8.81	.42	.60	.76	125.4	9.97	.42	.60	.79	114.8	11.27	.42	.62	.82

## 12.5 TON - LGT150H4E/P (2 COMPRESSORS - FULL LOAD)

Entering Wet Bulb Temperature	Total Air Volume	Outdoor Air Temperature Entering Outdoor Coil																			
		85°F					95°F					105°F					115°F				
		Total Cool Cap.	Comp. Motor Input	Sensible To Total Ratio (S/T)			Total Cool Cap.	Comp. Motor Input	Sensible To Total Ratio (S/T)			Total Cool Cap.	Comp. Motor Input	Sensible To Total Ratio (S/T)			Total Cool Cap.	Comp. Motor Input	Sensible To Total Ratio (S/T)		
				Dry Bulb					Dry Bulb					Dry Bulb					Dry Bulb		
		cfm	kBtuh	kW	75°F	80°F	85°F	kBtuh	kW	75°F	80°F	85°F	kBtuh	kW	75°F	80°F	85°F	kBtuh	kW	75°F	80°F
63°F	4000	141.6	8.86	.69	.83	.95	133.6	10.02	.71	.84	.97	125.1	11.31	.71	.86	.99	115.9	12.80	.73	.89	1.00
	5000	149.5	8.96	.75	.89	1.00	141.1	10.10	.76	.91	1.00	131.9	11.40	.79	.94	1.00	122.1	12.87	.81	.98	1.00
	6000	155.8	9.03	.80	.96	1.00	146.7	10.17	.82	.98	1.00	137.3	11.47	.84	1.00	1.00	127.6	12.94	.87	1.00	1.00
67°F	4000	148.9	8.94	.54	.67	.80	140.0	10.08	.54	.67	.81	130.3	11.36	.55	.70	.83	120.3	12.83	.55	.71	.86
	5000	155.4	9.01	.58	.73	.86	146.1	10.16	.58	.74	.88	136.2	11.44	.59	.76	.91	125.9	12.90	.61	.78	.95
	6000	160.4	9.07	.61	.78	.93	150.8	10.21	.63	.80	.95	141.1	11.51	.62	.82	.98	130.3	12.97	.65	.85	1.00
71°F	4000	158.3	9.04	.40	.52	.64	149.1	10.19	.40	.53	.66	139.1	11.48	.40	.54	.68	128.4	12.94	.39	.55	.69
	5000	164.9	9.12	.42	.57	.71	155.0	10.27	.42	.57	.73	144.6	11.56	.42	.59	.74	133.0	13.00	.42	.60	.77
	6000	169.7	9.18	.44	.60	.76	159.3	10.32	.43	.61	.78	148.3	11.61	.44	.63	.80	136.5	13.06	.44	.64	.83

# HUMIDITROL® DEHUMIDIFICATION SYSTEM RATINGS

## 7.5 TON - LGT092H4E WITH HUMIDITROL® OPERATING (PART LOAD)

Entering Wet Bulb Temperature	Total Air Volume	Outdoor Air Temperature Entering Outdoor Coil																			
		65°F					75°F					85°F					95°F				
		Total Cool Cap.	Comp. Motor Input	Sensible To Total Ratio (S/T)			Total Cool Cap.	Comp. Motor Input	Sensible To Total Ratio (S/T)			Total Cool Cap.	Comp. Motor Input	Sensible To Total Ratio (S/T)			Total Cool Cap.	Comp. Motor Input	Sensible To Total Ratio (S/T)		
				Dry Bulb					Dry Bulb					Dry Bulb					Dry Bulb		
cfm	kBtuh	kW	75°F	80°F	85°F	kBtuh	kW	75°F	80°F	85°F	kBtuh	kW	75°F	80°F	85°F	kBtuh	kW	75°F	80°F	85°F	
63°F	1440	34.8	2.1	0.60	0.83	0.95	27.7	2.3	0.54	0.82	0.98	20.6	2.6	0.48	0.82	0.99	13.4	2.8	0.42	0.80	1.00
	1800	37.1	2.1	0.64	0.86	0.97	28.9	2.3	0.60	0.87	0.99	20.7	2.5	0.56	0.87	1.00	12.5	2.8	0.51	0.87	1.00
	2160	39.4	2.1	0.69	0.89	0.99	30.1	2.3	0.66	0.92	0.99	20.9	2.5	0.63	0.93	1.00	11.6	2.8	0.60	0.95	1.00
67°F	1440	41.0	2.1	0.42	0.63	0.78	32.8	2.3	0.35	0.60	0.75	25.3	2.5	0.29	0.55	0.72	18.1	2.8	0.15	0.46	0.69
	1800	43.0	2.1	0.45	0.65	0.80	34.3	2.3	0.38	0.62	0.78	26.1	2.6	0.31	0.58	0.76	18.1	2.8	0.16	0.49	0.73
	2160	45.1	2.2	0.48	0.67	0.82	35.8	2.3	0.41	0.65	0.81	27.0	2.6	0.33	0.60	0.79	18.0	2.8	0.17	0.53	0.77
71°F	1440	45.8	2.1	0.25	0.43	0.61	38.4	2.4	0.17	0.35	0.53	31.0	2.6	0.10	0.28	0.46	23.5	2.8	-0.13	0.12	0.38
	1800	49.1	2.2	0.26	0.44	0.63	40.5	2.4	0.16	0.37	0.57	31.8	2.6	0.06	0.29	0.52	23.1	2.8	-0.19	0.14	0.46
	2160	52.4	2.2	0.26	0.46	0.65	42.5	2.4	0.15	0.39	0.62	32.6	2.6	0.03	0.31	0.59	22.8	2.8	-0.25	0.15	0.55

## 7.5 TON - LGT092H4E WITH HUMIDITROL® OPERATING (FULL LOAD)

Entering Wet Bulb Temperature	Total Air Volume	Outdoor Air Temperature Entering Outdoor Coil																			
		65°F					75°F					85°F					95°F				
		Total Cool Cap.	Comp. Motor Input	Sensible To Total Ratio (S/T)			Total Cool Cap.	Comp. Motor Input	Sensible To Total Ratio (S/T)			Total Cool Cap.	Comp. Motor Input	Sensible To Total Ratio (S/T)			Total Cool Cap.	Comp. Motor Input	Sensible To Total Ratio (S/T)		
				Dry Bulb					Dry Bulb					Dry Bulb					Dry Bulb		
cfm	kBtuh	kW	75°F	80°F	85°F	kBtuh	kW	75°F	80°F	85°F	kBtuh	kW	75°F	80°F	85°F	kBtuh	kW	75°F	80°F	85°F	
63°F	2400	78.6	4.0	0.61	0.76	0.91	66.4	4.4	0.59	0.78	0.97	54.2	4.9	0.58	0.80	1.00	41.8	5.6	0.57	0.82	1.00
	3000	83.7	4.0	0.64	0.81	0.97	71.1	4.5	0.65	0.85	1.00	57.9	5.0	0.66	0.89	1.00	43.6	5.6	0.67	0.93	1.00
	3600	88.9	4.1	0.67	0.88	1.00	75.9	4.5	0.72	0.92	1.00	61.7	5.0	0.74	0.92	1.00	45.4	5.6	0.76	1.00	1.00
67°F	2400	89.6	4.0	0.46	0.60	0.73	76.8	4.5	0.44	0.60	0.75	64.4	5.0	0.42	0.59	0.77	51.6	5.6	0.39	0.59	0.79
	3000	93.4	4.1	0.49	0.64	0.78	79.7	4.5	0.47	0.63	0.79	66.5	5.1	0.45	0.62	0.79	52.0	5.6	0.44	0.61	0.80
	3600	97.2	4.1	0.52	0.67	0.82	82.7	4.6	0.52	0.67	0.82	68.5	5.1	0.50	0.65	0.82	52.3	5.7	0.48	0.63	0.82
71°F	2400	100.6	4.1	0.31	0.43	0.55	87.3	4.6	0.28	0.41	0.54	74.7	5.1	0.2	0.38	0.53	61.4	5.7	0.21	0.36	0.51
	3000	106.1	4.2	0.34	0.47	0.60	92.2	4.6	0.30	0.44	0.59	78.6	5.1	0.25	0.42	0.58	62.3	5.7	0.21	0.39	0.56
	3600	111.6	4.2	0.37	0.51	0.65	97.1	4.7	0.32	0.48	0.64	82.6	5.1	0.26	0.45	0.64	63.1	5.7	0.21	0.41	0.62

## 8.5 TON - LGT102H4E WITH HUMIDITROL® OPERATING (PART LOAD)

Entering Wet Bulb Temperature	Total Air Volume	Outdoor Air Temperature Entering Outdoor Coil																			
		65°F					75°F					85°F					95°F				
		Total Cool Cap.	Comp. Motor Input	Sensible To Total Ratio (S/T)			Total Cool Cap.	Comp. Motor Input	Sensible To Total Ratio (S/T)			Total Cool Cap.	Comp. Motor Input	Sensible To Total Ratio (S/T)			Total Cool Cap.	Comp. Motor Input	Sensible To Total Ratio (S/T)		
				Dry Bulb					Dry Bulb					Dry Bulb					Dry Bulb		
cfm	kBtuh	kW	75°F	80°F	85°F	kBtuh	kW	75°F	80°F	85°F	kBtuh	kW	75°F	80°F	85°F	kBtuh	kW	75°F	80°F	85°F	
63°F	1600	35.8	2.1	0.62	0.84	0.96	28.2	2.3	0.57	0.83	0.98	20.6	2.6	0.51	0.83	0.99	13.0	2.8	0.46	0.81	1.00
	2000	38.4	2.1	0.67	0.88	0.98	29.6	2.3	0.63	0.90	0.99	20.8	2.5	0.60	0.92	1.00	12.0	2.8	0.56	0.94	1.00
	2400	41.0	2.1	0.72	0.92	1.00	31.0	2.3	0.70	0.94	1.00	21.0	2.5	0.68	0.95	1.00	11.0	2.7	0.66	0.97	1.00
67°F	1600	41.9	2.1	0.43	0.64	0.79	33.7	2.3	0.37	0.61	0.76	25.9	2.6	0.30	0.56	0.74	18.1	2.8	0.15	0.47	0.71
	2000	44.2	2.2	0.47	0.66	0.81	35.0	2.3	0.40	0.64	0.79	26.4	2.6	0.32	0.59	0.78	18.0	2.8	0.17	0.51	0.75
	2400	46.4	2.2	0.50	0.69	0.83	37.1	2.3	0.43	0.67	0.82	27.8	2.6	0.34	0.62	0.81	17.9	2.8	0.18	0.55	0.80
71°F	1600	47.3	2.1	0.25	0.43	0.61	39.3	2.4	0.17	0.36	0.55	31.3	2.6	0.08	0.28	0.48	23.4	2.8	-0.16	0.13	0.42
	2000	50.9	2.2	0.26	0.45	0.64	41.6	2.4	0.16	0.38	0.60	32.3	2.6	0.04	0.30	0.56	22.9	2.8	-0.22	0.14	0.51
	2400	54.6	2.2	0.27	0.47	0.66	43.9	2.4	0.15	0.40	0.65	33.2	2.6	0.00	0.32	0.63	22.5	2.8	-0.29	0.16	0.60

## 8.5 TON - LGT102H4E WITH HUMIDITROL® OPERATING (FULL LOAD)

Entering Wet Bulb Temperature	Total Air Volume	Outdoor Air Temperature Entering Outdoor Coil																			
		65°F					75°F					85°F					95°F				
		Total Cool Cap.	Comp. Motor Input	Sensible To Total Ratio (S/T)			Total Cool Cap.	Comp. Motor Input	Sensible To Total Ratio (S/T)			Total Cool Cap.	Comp. Motor Input	Sensible To Total Ratio (S/T)			Total Cool Cap.	Comp. Motor Input	Sensible To Total Ratio (S/T)		
				Dry Bulb					Dry Bulb					Dry Bulb					Dry Bulb		
cfm	kBtuh	kW	75°F	80°F	85°F	kBtuh	kW	75°F	80°F	85°F	kBtuh	kW	75°F	80°F	85°F	kBtuh	kW	75°F	80°F	85°F	
63°F	2720	83.8	4.2	0.60	0.76	0.93	71.2	4.7	0.58	0.77	0.93	58.1	5.2	0.55	0.77	0.94	46.4	5.8	0.53	0.78	0.94
	3400	88.4	4.3	0.66	0.85	0.94	74.5	4.7	0.64	0.86	0.94	60.4	5.3	0.62	0.88	0.95	46.9	5.9	0.60	0.89	0.95
	4080	93.0	4.3	0.72	0.94	0.94	77.8	4.7	0.70	0.94	0.95	62.6	5.3	0.69	0.95	0.96	47.4	5.9	0.67	0.95	0.96
67°F	2720	94.6	4.3	0.43	0.58	0.72	81.2	4.7	0.39	0.56	0.71	68.6	5.3	0.35	0.53	0.70	53.1	5.9	0.31	0.51	0.69
	3400	98.7	4.3	0.48	0.64	0.74	84.7	4.8	0.43	0.62	0.73	70.0	5.3	0.39	0.60	0.73	53.8	5.9	0.35	0.60	0.73
	4080	102.8	4.3	0.52	0.70	0.76	88.2	4.8	0.47	0.68	0.76	71.4	5.3	0.43	0.68	0.77	54.6	5.9	0.38	0.68	0.77
71°F	2720	108.3	4.3	0.29	0.43	0.56	93.9	4.9	0.24	0.39	0.54	79.6	5.4	0.18	0.35	0.51	65.3	5.9	0.11	0.31	0.49
	3400	115.2	4.3	0.33	0.47	0.60	99.1	4.9	0.26	0.42	0.59	83.1	5.4	0.19	0.38	0.57	67.0	5.9	0.11	0.33	0.55
	4080	122.1	4.3	0.37	0.51	0.65	104.3	4.9	0.28	0.46	0.64	86.5	5.4	0.19	0.41	0.62	68.7	5.9	0.11	0.36	0.61

# HUMIDITROL® DEHUMIDIFICATION SYSTEM RATINGS

## 10 TON - LGT120H4E WITH HUMIDITROL® OPERATING (PART LOAD)

Entering Wet Bulb Temperature	Total Air Volume	Outdoor Air Temperature Entering Outdoor Coil																			
		65°F					75°F					85°F					95°F				
		Total Cool Cap.	Comp. Motor Input	Sensible To Total Ratio (S/T)			Total Cool Cap.	Comp. Motor Input	Sensible To Total Ratio (S/T)			Total Cool Cap.	Comp. Motor Input	Sensible To Total Ratio (S/T)			Total Cool Cap.	Comp. Motor Input	Sensible To Total Ratio (S/T)		
				Dry Bulb					Dry Bulb					Dry Bulb					Dry Bulb		
cfm	kBtuh	kW	75°F	80°F	85°F	kBtuh	kW	75°F	80°F	85°F	kBtuh	kW	75°F	80°F	85°F	kBtuh	kW	75°F	80°F	85°F	
63°F	2000	43.1	2.6	0.59	0.80	0.96	34.7	2.9	0.53	0.79	0.97	26.2	3.2	0.46	0.78	0.98	17.8	3.5	0.39	0.76	1.00
	2400	45.6	2.6	0.63	0.83	0.98	36.2	2.9	0.56	0.83	0.99	26.7	3.2	0.48	0.81	1.00	17.2	3.5	0.41	0.80	1.00
	2800	48.1	2.7	0.67	0.87	0.99	37.6	2.9	0.59	0.87	1.00	27.2	3.2	0.51	0.85	1.00	16.7	3.5	0.43	0.83	1.00
67°F	2000	49.1	2.7	0.42	0.56	0.77	40.6	3.0	0.32	0.52	0.76	32.2	3.3	0.23	0.46	0.74	23.8	3.6	0.13	0.42	0.72
	2400	52.3	2.7	0.42	0.60	0.79	42.7	3.0	0.32	0.56	0.79	33.0	3.3	0.22	0.51	0.80	23.4	3.5	0.12	0.47	0.80
	2800	55.5	2.7	0.43	0.64	0.80	44.7	3.0	0.33	0.60	0.82	33.9	3.3	0.22	0.56	0.85	23.1	3.5	0.12	0.52	0.89
71°F	2000	55.0	2.7	0.24	0.40	0.56	46.6	3.0	0.12	0.32	0.53	38.1	3.3	0.00	0.23	0.47	29.7	3.6	-0.22	0.08	0.38
	2400	59.0	2.8	0.23	0.41	0.59	49.2	3.1	0.12	0.33	0.55	39.4	3.3	0.00	0.25	0.50	29.6	3.6	-0.25	0.09	0.43
	2800	63.0	2.8	0.21	0.41	0.61	51.8	3.1	0.11	0.34	0.57	40.6	3.3	0.01	0.27	0.53	29.4	3.6	-0.27	0.11	0.49

## 10 TON - LGT120H4E WITH HUMIDITROL® OPERATING (FULL LOAD)

Entering Wet Bulb Temperature	Total Air Volume	Outdoor Air Temperature Entering Outdoor Coil																			
		65°F					75°F					85°F					95°F				
		Total Cool Cap.	Comp. Motor Input	Sensible To Total Ratio (S/T)			Total Cool Cap.	Comp. Motor Input	Sensible To Total Ratio (S/T)			Total Cool Cap.	Comp. Motor Input	Sensible To Total Ratio (S/T)			Total Cool Cap.	Comp. Motor Input	Sensible To Total Ratio (S/T)		
				Dry Bulb					Dry Bulb					Dry Bulb					Dry Bulb		
cfm	kBtuh	kW	75°F	80°F	85°F	kBtuh	kW	75°F	80°F	85°F	kBtuh	kW	75°F	80°F	85°F	kBtuh	kW	75°F	80°F	85°F	
63°F	3200	105.1	5.2	0.59	0.72	0.86	91.1	5.9	0.57	0.72	0.87	77.2	6.5	0.54	0.74	0.89	63.3	7.2	0.52	0.80	0.90
	4000	111.4	5.3	0.63	0.76	0.90	94.8	5.9	0.62	0.78	0.91	78.3	6.5	0.61	0.80	0.93	61.7	7.2	0.60	0.82	0.95
	4800	117.7	5.3	0.66	0.80	0.93	98.5	5.9	0.67	0.81	0.95	79.4	6.6	0.68	0.86	0.97	60.2	7.2	0.68	0.84	1.00
67°F	3200	116.6	5.3	0.43	0.57	0.72	102.9	6.0	0.40	0.56	0.72	88.5	6.6	0.36	0.54	0.71	73.4	7.3	0.33	0.52	0.70
	4000	123.8	5.4	0.46	0.59	0.75	107.5	6.0	0.42	0.59	0.75	91.8	6.6	0.38	0.57	0.75	72.4	7.3	0.34	0.55	0.75
	4800	131.0	5.4	0.48	0.63	0.78	112.2	6.0	0.44	0.61	0.78	95.1	6.6	0.40	0.59	0.78	71.4	7.3	0.36	0.58	0.79
71°F	3200	128.1	5.5	0.27	0.42	0.56	114.6	6.0	0.23	0.38	0.53	99.7	6.7	0.18	0.34	0.50	83.5	7.4	0.14	0.31	0.48
	4000	136.2	5.5	0.30	0.44	0.59	120.2	6.1	0.25	0.41	0.57	105.3	6.7	0.20	0.38	0.55	83.0	7.4	0.16	0.34	0.53
	4800	144.2	5.6	0.32	0.47	0.62	125.9	6.1	0.27	0.44	0.61	110.8	6.7	0.23	0.41	0.59	82.5	7.4	0.18	0.38	0.58

## 12.5 TON - LGT150H4E WITH HUMIDITROL® OPERATING (PART LOAD)

Entering Wet Bulb Temperature	Total Air Volume	Outdoor Air Temperature Entering Outdoor Coil																			
		65°F					75°F					85°F					95°F				
		Total Cool Cap.	Comp. Motor Input	Sensible To Total Ratio (S/T)			Total Cool Cap.	Comp. Motor Input	Sensible To Total Ratio (S/T)			Total Cool Cap.	Comp. Motor Input	Sensible To Total Ratio (S/T)			Total Cool Cap.	Comp. Motor Input	Sensible To Total Ratio (S/T)		
				Dry Bulb					Dry Bulb					Dry Bulb					Dry Bulb		
cfm	kBtuh	kW	75°F	80°F	85°F	kBtuh	kW	75°F	80°F	85°F	kBtuh	kW	75°F	80°F	85°F	kBtuh	kW	75°F	80°F	85°F	
63°F	2080	46.2	3.1	0.59	0.79	0.97	37.0	3.4	0.52	0.78	0.97	27.8	3.8	0.45	0.79	0.99	18.6	4.2	0.36	0.79	1.00
	2600	47.6	3.1	0.67	0.85	1.00	37.6	3.5	0.58	0.86	1.00	27.6	3.8	0.48	0.87	1.00	17.6	4.2	0.39	0.88	1.00
	3120	49.0	3.1	0.75	0.92	1.00	38.2	3.5	0.63	0.94	1.00	27.4	3.8	0.52	0.96	1.00	16.6	4.2	0.41	0.96	1.00
67°F	2080	52.7	3.2	0.40	0.57	0.74	43.4	3.5	0.31	0.53	0.73	33.0	3.9	0.22	0.48	0.72	24.7	4.2	0.07	0.43	0.72
	2600	55.1	3.2	0.45	0.63	0.80	44.6	3.5	0.34	0.59	0.78	33.9	3.9	0.24	0.55	0.76	23.7	4.2	0.05	0.48	0.74
	3120	57.5	3.2	0.49	0.69	0.85	45.8	3.6	0.36	0.66	0.82	34.7	3.8	0.25	0.62	0.79	22.6	4.2	0.02	0.53	0.76
71°F	2080	59.2	3.2	0.21	0.39	0.56	49.8	3.6	0.10	0.31	0.51	40.3	4.0	0.00	0.23	0.45	30.9	4.3	-0.22	0.09	0.39
	2600	62.6	3.3	0.22	0.41	0.59	51.6	3.6	0.10	0.33	0.55	40.7	4.0	-0.02	0.25	0.51	29.7	4.3	-0.30	0.09	0.47
	3120	65.9	3.3	0.24	0.43	0.62	53.5	3.7	0.10	0.35	0.59	41.0	4.0	-0.03	0.27	0.57	28.6	4.3	-0.37	0.09	0.55

## 12.5 TON - LGT150H4E WITH HUMIDITROL® OPERATING (FULL LOAD)

Entering Wet Bulb Temperature	Total Air Volume	Outdoor Air Temperature Entering Outdoor Coil																			
		65°F					75°F					85°F					95°F				
		Total Cool Cap.	Comp. Motor Input	Sensible To Total Ratio (S/T)			Total Cool Cap.	Comp. Motor Input	Sensible To Total Ratio (S/T)			Total Cool Cap.	Comp. Motor Input	Sensible To Total Ratio (S/T)			Total Cool Cap.	Comp. Motor Input	Sensible To Total Ratio (S/T)		
				Dry Bulb					Dry Bulb					Dry Bulb					Dry Bulb		
cfm	kBtuh	kW	75°F	80°F	85°F	kBtuh	kW	75°F	80°F	85°F	kBtuh	kW	75°F	80°F	85°F	kBtuh	kW	75°F	80°F	85°F	
63°F	4000	126.1	7.0	0.61	0.79	0.88	110.4	7.8	0.60	0.79	0.89	94.8	8.6	0.59	0.81	0.90	79.2	9.4	0.57	0.83	0.92
	5000	129.1	7.1	0.66	0.83	0.92	112.8	7.9	0.66	0.84	0.93	96.6	8.7	0.67	0.86	0.95	80.4	9.5	0.68	0.87	0.96
	6000	132.1	7.1	0.70	0.87	0.97	115.3	7.9	0.73	0.89	0.98	98.4	8.7	0.75	0.90	0.99	81.5	9.6	0.78	0.90	1.00
67°F	4000	138.9	7.1	0.45	0.61	0.73	122.6	8.0	0.42	0.61	0.73	106.2	8.7	0.39	0.61	0.73	89.9	9.6	0.36	0.61	0.73
	5000	142.8	7.2	0.49	0.64	0.77	125.4	8.0	0.47	0.64	0.78	107.9	8.8	0.44	0.64	0.78	90.4	9.6	0.42	0.64	0.79
	6000	146.8	7.3	0.53	0.67	0.82	128.2	8.0	0.51	0.67	0.83	109.6	8.8	0.50	0.67	0.84	90.9	9.7	0.48	0.67	0.85
71°F	4000	151.8	7.3	0.29	0.43	0.57	134.7	8.1	0.24	0.40	0.56	117.6	8.9	0.19	0.37	0.55	100.6	9.7	0.14	0.34	0.55
	5000	156.6	7.4	0.32	0.47	0.62	137.9	8.1	0.27	0.44	0.62	119.2	8.9	0.22	0.42	0.62	100.5	9.7	0.16	0.39	0.62
	6000	161.4	7.4	0.36	0.51	0.67	141.1	8.2	0.30	0.49	0.68	120.7	9.0	0.24	0.46	0.68	100.4	9.7	0.19	0.44	0.69

## BLOWER DATA

**BLOWER TABLE INCLUDES RESISTANCE FOR BASE UNIT ONLY (NO HEAT SECTION) WITH DRY INDOOR COIL AND AIR FILTERS IN PLACE.**

FOR ALL UNITS ADD:

- 1 - Wet indoor coil air resistance of selected unit.
  - 2 - Any factory installed options air resistance (heat section, Economizer, etc.)
  - 3 - Any field installed accessories air resistance (duct resistance, diffuser, etc.)
- See page 33 for wet coil and option/accessory air resistance data.

**Maximum Static Pressure With Gas Heat - 2.0 in. w.g.**

**Minimum Air Volume Required For Different Gas Heat Sizes:**

Standard - 2150 cfm; Medium - 2250 cfm; High - 2600 cfm

Total Air Volume cfm	Total Static Pressure - in. w.g.													
	0.2		0.4		0.6		0.8		1.0		1.2		1.4	
	RPM	Watts	RPM	Watts	RPM	Watts	RPM	Watts	RPM	Watts	RPM	Watts	RPM	Watts
1750	759	223	864	298	961	359	1049	420	1128	508	1199	607	1260	704
2000	846	271	943	345	1035	410	1117	488	1189	598	1255	704	1313	804
2250	945	303	1030	391	1111	476	1184	577	1247	697	1310	806	1367	905
2500	1035	366	1109	476	1180	583	1245	688	1306	797	1368	903	1426	1008
2750	1113	476	1182	601	1248	715	1310	809	1371	902	1432	1011	1491	1129
3000	1195	596	1261	718	1324	827	1385	922	1444	1024	1503	1146	1559	1279
3250	1282	711	1346	827	1406	935	1464	1044	1521	1167	1576	1306	1629	1460
3500	1372	821	1432	940	1489	1060	1544	1192	1598	1337	1650	1494	1700	1663
3750	1461	949	1517	1081	1571	1221	1624	1373	1675	1532	1725	1700	1773	1875
4000	1549	1109	1602	1256	1653	1413	1703	1576	1753	1743	1801	1916	1847	2091
4250	1637	1298	1687	1458	1735	1625	1784	1795	1831	1966	1877	2139	1923	2310
4500	1724	1510	1772	1678	1818	1851	1864	2023	1910	2195	1955	2365	2000	2530
4750	1811	1738	1856	1910	1901	2083	1946	2254	1990	2423	2034	2587	2079	2746
5000	1897	1973	1941	2144	1985	2314	2028	2480	2071	2644	2114	2805	2158	2959
5250	1983	2205	2026	2373	2069	2538	2111	2699	2153	2860	2195	3017	---	---
5500	2070	2428	2112	2595	2153	2756	2194	2912	---	---	---	---	---	---
5750	2156	2643	2197	2809	---	---	---	---	---	---	---	---	---	---

Total Air Volume cfm	Total Static Pressure - in. w.g.											
	1.6		1.8		2.0		2.2		2.4		2.6	
	RPM	Watts	RPM	Watts	RPM	Watts	RPM	Watts	RPM	Watts	RPM	Watts
1750	1316	793	1373	875	1432	963	1491	1064	1548	1175	1604	1300
2000	1368	894	1425	982	1483	1081	1540	1196	1596	1322	1650	1458
2250	1423	1001	1480	1101	1537	1216	1593	1344	1647	1483	1700	1629
2500	1483	1117	1539	1236	1594	1368	1648	1509	1700	1657	1752	1810
2750	1547	1256	1601	1394	1654	1539	1705	1690	1756	1846	1806	2004
3000	1612	1425	1664	1577	1715	1734	1765	1893	1815	2053	1864	2213
3250	1680	1623	1729	1787	1778	1949	1828	2110	1876	2269	1925	2426
3500	1748	1835	1796	2003	1844	2165	1893	2324	1942	2479	1991	2633
3750	1819	2048	1866	2214	1914	2374	1963	2530	2012	2684	2061	2837
4000	1893	2260	1940	2423	1988	2581	2036	2737	2084	2891	2134	3044
4250	1969	2475	2016	2634	2063	2790	2111	2945	2159	3098	---	---
4500	2046	2689	2093	2844	2140	2998	2187	3153	---	---	---	---
4750	2124	2900	2170	3053	---	---	---	---	---	---	---	---
5000	2203	3111	---	---	---	---	---	---	---	---	---	---
5250	---	---	---	---	---	---	---	---	---	---	---	---
5500	---	---	---	---	---	---	---	---	---	---	---	---



## BLOWER DATA

### FACTORY INSTALLED OPTIONS/FIELD INSTALLED ACCESSORY AIR RESISTANCE - in. w.g.

Air Volume cfm	Wet Indoor Coil		Gas Heat Exchanger			Economizer	Humiditrol® Reheat Coil	Filters			Return Air Adaptor Plate
			Standard Heat	Medium Heat	High Heat			MERV 8	MERV 13	MERV 16	
	092, 102	120, 150									
1750	0.04	0.04	0.06	0.02	0.02	0.05	0.02	0.01	0.03	0.06	0.00
2000	0.05	0.05	0.07	0.05	0.06	0.06	0.02	0.01	0.03	0.08	0.00
2250	0.06	0.06	0.07	0.07	0.08	0.08	0.02	0.01	0.04	0.09	0.00
2500	0.07	0.07	0.09	0.10	0.11	0.11	0.03	0.01	0.05	0.10	0.00
2750	0.08	0.08	0.09	0.11	0.12	0.12	0.03	0.02	0.05	0.11	0.00
3000	0.10	0.09	0.11	0.12	0.13	0.13	0.03	0.02	0.06	0.12	0.02
3250	0.11	0.10	0.12	0.15	0.16	0.15	0.04	0.02	0.06	0.13	0.02
3500	0.12	0.11	0.12	0.16	0.17	0.15	0.04	0.03	0.07	0.15	0.04
3750	0.14	0.13	0.14	0.19	0.20	0.15	0.05	0.03	0.08	0.16	0.07
4000	0.15	0.14	0.14	0.21	0.22	0.19	0.05	0.04	0.08	0.17	0.09
4250	0.17	0.15	0.14	0.24	0.28	0.19	0.06	0.04	0.09	0.19	0.11
4500	0.19	0.17	0.15	0.26	0.32	0.22	0.07	0.04	0.09	0.20	0.12
4750	0.20	0.18	0.16	0.29	0.37	0.25	0.07	0.05	0.10	0.21	0.16
5000	0.22	0.20	0.16	0.34	0.43	0.29	0.08	0.06	0.10	0.23	0.18
5250	0.24	0.22	0.16	0.37	0.47	0.32	0.08	0.06	0.11	0.24	0.19
5500	0.25	0.23	0.18	0.44	0.54	0.34	0.09	0.07	0.12	0.25	0.22
5750	0.27	0.25	0.19	0.49	0.59	0.45	0.10	0.07	0.12	0.27	0.25
6000	0.29	0.27	0.20	0.54	0.64	0.52	0.10	0.08	0.13	0.28	0.27

### POWER EXHAUST FAN PERFORMANCE

Return Air System Static Pressure	Air Volume Exhausted
in. w.g.	cfm
0	3175
0.05	2955
0.10	2685
0.15	2410
0.20	2165
0.25	1920
0.30	1420
0.35	1200

## BLOWER DATA

### CEILING DIFFUSERS AIR RESISTANCE - in. w.g.

Unit Size	RTD11 Step-Down Diffuser				FD11 Flush Diffuser
	Air Volume cfm	2 Ends Open	1 Side, 2 Ends Open	All Ends & Sides Open	
092 Models	2400	0.21	0.18	0.15	0.14
	2600	0.24	0.21	0.18	0.17
	2800	0.27	0.24	0.21	0.20
	3000	0.32	0.29	0.25	0.25
	3200	0.41	0.37	0.32	0.31
	3400	0.50	0.45	0.39	0.37
	3600	0.61	0.54	0.48	0.44
102 & 120 Models	3800	0.73	0.63	0.57	0.51
	3600	0.36	0.28	0.23	0.15
	3800	0.40	0.32	0.26	0.18
	4000	0.44	0.36	0.29	0.21
	4200	0.49	0.40	0.33	0.24
	4400	0.54	0.44	0.37	0.27
	4600	0.60	0.49	0.42	0.31
	4800	0.65	0.53	0.46	0.35
150 Models	5000	0.69	0.58	0.50	0.39
	5200	0.75	0.62	0.54	0.43
	4200	0.22	0.19	0.16	0.10
	4400	0.28	0.24	0.20	0.12
	4600	0.34	0.29	0.24	0.15
	4800	0.40	0.34	0.29	0.19
	5000	0.46	0.39	0.34	0.23
	5200	0.52	0.44	0.39	0.27
	5400	0.58	0.49	0.43	0.31
5600	0.64	0.54	0.47	0.35	
5800	0.70	0.59	0.51	0.39	

### CEILING DIFFUSER AIR THROW DATA

Model No.	Air Volume cfm	<sup>1</sup> Effective Throw Range	
		RTD11 Step-Down	FD11 Flush
		ft.	ft.
092 Models	2600	24 - 29	19 - 24
	2800	25 - 30	20 - 28
	3000	27 - 33	21 - 29
	3200	28 - 35	22 - 29
	3400	30 - 37	22 - 30
102, 120 Models	3600	25 - 33	22 - 29
	3800	27 - 35	22 - 30
	4000	29 - 37	24 - 33
	4200	32 - 40	26 - 35
	4400	34 - 42	28 - 37
150 Models	5600	39 - 49	28 - 37
	5800	42 - 51	29 - 38
	6000	44 - 54	40 - 50
	6200	45 - 55	42 - 51
	6400	46 - 55	43 - 52
	6600	47 - 56	45 - 56

<sup>1</sup> Throw is the horizontal or vertical distance an air stream travels on leaving the outlet or diffuser before the maximum velocity is reduced to 50 ft. per minute. Four sides open.

**ELECTRICAL DATA****7.5 TON**

Model No.		LGT092H4E / LGT092H4P		
<sup>1</sup> Voltage - 60Hz		208/230V-3ph	460V-3ph	575V-3ph
Compressor 1 (Non-Inverter)	Rated Load Amps	12.9	7.1	4.6
	Locked Rotor Amps	105	62	39
Compressor 2 (Non-Inverter)	Rated Load Amps	13.1	6.1	4.4
	Locked Rotor Amps	83.1	41	33
Outdoor Fan Motors (2)	Full Load Amps (2 Non-ECM)	2.4	1.3	1
Power Exhaust (1) 0.33 HP	Full Load Amps	2.4	1.3	1
Service Outlet 115V GFI (amps)		15	15	20
Indoor Blower Motor	Horsepower	3.75	3.75	3.75
	Full Load Amps	8.8	4.3	3.4
<sup>2</sup> Maximum Overcurrent Protection (MOCP)	Unit Only	50	25	20
	With (1) 0.33 HP Power Exhaust	50	30	20
<sup>3</sup> Minimum Circuit Ampacity (MCA)	Unit Only	43	22	16
	With (1) 0.33 HP Power Exhaust	46	24	17

NOTE - All units have a minimum Short Circuit Current Rating (SCCR) of 5000 amps.

<sup>1</sup> Extremes of operating range are plus and minus 10% of line voltage.<sup>2</sup> HACR type breaker or fuse.<sup>3</sup> Refer to National or Canadian Electrical Code manual to determine wire, fuse and disconnect size requirements.**ELECTRICAL DATA****8.5 TON**

Model No.		LGT102H4E / LGT102H4P		
<sup>1</sup> Voltage - 60Hz		208/230V-3ph	460V-3ph	575V-3ph
Compressor 1 (Non-Inverter)	Rated Load Amps	12.9	7.1	4.6
	Locked Rotor Amps	105	62	39
Compressor 2 (Non-Inverter)	Rated Load Amps	13.7	6.1	4.8
	Locked Rotor Amps	83.1	43	33
Outdoor Fan Motors (2)	Full Load Amps (2 Non-ECM)	2.4	1.3	1
Power Exhaust (1) 0.33 HP	Full Load Amps	2.4	1.3	1
Service Outlet 115V GFI (amps)		15	15	20
Indoor Blower Motor	Horsepower	3.75	3.75	3.75
	Full Load Amps	8.8	4.3	3.4
<sup>2</sup> Maximum Overcurrent Protection (MOCP)	Unit Only	50	25	20
	With (1) 0.33 HP Power Exhaust	50	30	20
<sup>3</sup> Minimum Circuit Ampacity (MCA)	Unit Only	44	22	16
	With (1) 0.33 HP Power Exhaust	47	24	17

NOTE - All units have a minimum Short Circuit Current Rating (SCCR) of 5000 amps.

<sup>1</sup> Extremes of operating range are plus and minus 10% of line voltage.<sup>2</sup> HACR type breaker or fuse.<sup>3</sup> Refer to National or Canadian Electrical Code manual to determine wire, fuse and disconnect size requirements.

**ELECTRICAL DATA****10 TON**

Model No.		LGT120H4E / LGT120H4P		
<sup>1</sup> Voltage - 60Hz		208/230V-3ph	460V-3ph	575V-3ph
Compressor 1 (Non-Inverter)	Rated Load Amps	16.7	7.1	5.7
	Locked Rotor Amps	110	54.7	47.8
Compressor 2 (Non-Inverter)	Rated Load Amps	16	7.8	5.7
	Locked Rotor Amps	110	52	38.9
Outdoor Fan Motors (2)	Full Load Amps (2 Non-ECM)	3	1.5	1.2
Power Exhaust (1) 0.33 HP	Full Load Amps	2.4	1.3	1
Service Outlet 115V GFI (amps)		15	15	20
Indoor Blower Motor	Horsepower	3.75	3.75	3.75
	Full Load Amps	8.8	4.3	3.4
<sup>2</sup> Maximum Overcurrent Protection (MOCP)	Unit Only	60	30	20
	With (1) 0.33 HP Power Exhaust	70	30	25
<sup>3</sup> Minimum Circuit Ampacity (MCA)	Unit Only	52	25	19
	With (1) 0.33 HP Power Exhaust	55	26	20

NOTE - All units have a minimum Short Circuit Current Rating (SCCR) of 5000 amps.

<sup>1</sup> Extremes of operating range are plus and minus 10% of line voltage.<sup>2</sup> HACR type breaker or fuse.<sup>3</sup> Refer to National or Canadian Electrical Code manual to determine wire, fuse and disconnect size requirements.**ELECTRICAL DATA****12.5 TON**

Model No.		LGT150H4E/ LGT150H4P		
<sup>1</sup> Voltage - 60Hz		208/230V-3ph	460V-3ph	575V-3ph
Compressor 1 (Non-Inverter)	Rated Load Amps	17.6	8.5	6.3
	Locked Rotor Amps	136	66.1	55.3
Compressor 2 (Non-Inverter)	Rated Load Amps	22.6	10	7.5
	Locked Rotor Amps	166.2	74.6	54
Outdoor Fan Motors (2)	Full Load Amps (2 Non-ECM)	3	1.5	1.2
Power Exhaust (1) 0.33 HP	Full Load Amps	2.4	1.3	1
Service Outlet 115V GFI (amps)		15	15	20
Indoor Blower Motor	Horsepower	3.75	3.75	3.75
	Full Load Amps	8.8	4.3	3.4
<sup>2</sup> Maximum Overcurrent Protection (MOCP)	Unit Only	80	35	25
	With (1) 0.33 HP Power Exhaust	80	35	25
<sup>3</sup> Minimum Circuit Ampacity (MCA)	Unit Only	61	29	22
	With (1) 0.33 HP Power Exhaust	64	30	23

NOTE - All units have a minimum Short Circuit Current Rating (SCCR) of 5000 amps.

<sup>1</sup> Extremes of operating range are plus and minus 10% of line voltage.<sup>2</sup> HACR type breaker or fuse.<sup>3</sup> Refer to National or Canadian Electrical Code manual to determine wire, fuse and disconnect size requirements.**FIELD WIRING NOTES**

- For use with copper wiring only
- Field wiring not furnished
- All wiring must conform to NEC or CEC and local electrical codes
- For specific wiring information, please refer to the installation instructions

## UNIT CLEARANCES

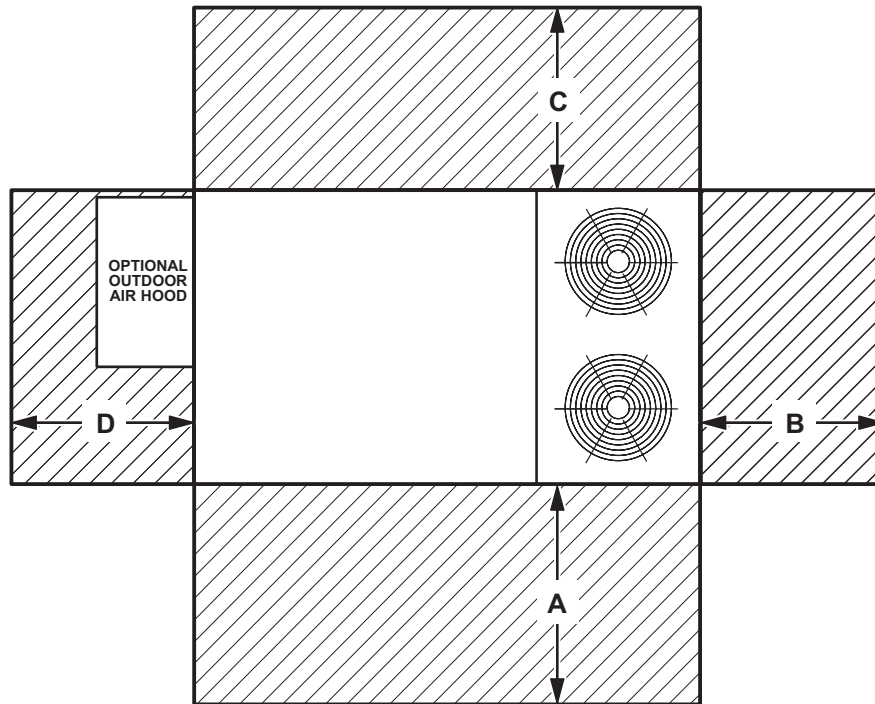

<sup>1</sup> Unit Clearance	A		B		C		D		Top Clearance
	in.	mm	in.	mm	in.	mm	in.	mm	
<b>Service Clearance</b>	60	1524	36	914	36	934	60	1524	Unobstructed
<b>Clearance to Combustibles</b>	36	914	1	25	1	25	1	25	
<b>Minimum Operation Clearance</b>	36	914	36	914	36	914	36	914	

NOTE - Entire perimeter of unit base requires support when elevated above the mounting surface.

<sup>1</sup> Service Clearance - Required for removal of serviceable parts.

Clearance to Combustibles - Required clearance to combustible material.

Minimum Operation Clearance - Required clearance for proper unit operation.

## OUTDOOR SOUND DATA

Unit Model Number	Octave Band Sound Power Levels dBA, re 10 <sup>-12</sup> Watts - Center Frequency - Hz							<sup>1</sup> Sound Rating Number (dBA)
	125	250	500	1000	2000	4000	8000	
092, 102	76	79	84	83	79	73	66	88
120, 150	70	77	85	84	80	78	76	89

Note - The octave sound power data does not include tonal corrections.

<sup>1</sup> Sound Rating Number according to AHRI Standard 370-2001 (includes pure tone penalty). Sound Rating Number is the overall A-Weighted Sound Power Level, (LWA), dBA (100 Hz to 10,000 Hz).

WEIGHT DATA				UNIT
Model Number	Net		Shipping	
	lbs.	kg	lbs.	kg
092 Base Unit	1088	494	1173	532
092 Max. Unit	1239	562	1324	601
102 Base Unit	1095	497	1180	535
102 Max. Unit	1246	565	1331	604
120 Base Unit	1130	513	1215	551
120 Max. Unit	1281	581	1366	620
150 Base Unit	1150	521	1235	560
150 Max. Unit	1301	590	1386	628

WEIGHT DATA		OPTIONS / ACCESSORIES	
		Shipping Weight	
		lbs.	kg
<b>ECONOMIZER / OUTDOOR AIR / EXHAUST</b>			
<b>Economizer</b>			
Economizer Dampers		60	27
Outdoor Air Hood (downflow)		23	10
Barometric Relief Dampers (downflow)		8	4
Barometric Relief Dampers (low profile horizontal)		20	9
<b>Outdoor Air Dampers</b>			
Motorized		51	23
Manual		39	18
<b>Power Exhaust</b>		31	14
<b>GAS HEAT EXCHANGER (NET WEIGHT)</b>			
Medium Heat (adder over standard heat)		9	5
High Heat (adder over standard heat)		32	15
<b>COMBINATION COIL/HAIL GUARDS</b>			
All models		55	25
<b>ROOF CURBS</b>			
<b>Hybrid Roof Curbs, Downflow</b>			
8 in. height		103	47
14 in. height		125	57
18 in. height		147	67
24 in. height		169	77
<b>Adjustable Pitch Curb, Downflow</b>			
14 in. height		169	77
<b>CEILING DIFFUSERS</b>			
Step-Down	RTD11-95S	118	54
	RTD11-135S	135	61
	RTD11-185S	168	76
Flush	FD11-95S	118	54
	FD11-135S	135	61
	FD11-185S	168	76
Transitions	C1DIFF30B-1	30	14
	C1DIFF31B-1	32	15
	C1DIFF32B-1	36	16
<b>HUMIDITROL® DEHUMIDIFICATION SYSTEM</b>			
Humiditrol® Dehumidification Option		20	9

# DIMENSIONS

# UNIT

Model No.	CORNER WEIGHTS														CENTER OF GRAVITY									
	AA				BB				CC				DD				EE				FF			
	Base		Max.		Base		Max.		Base		Max.		Base		Max.		Base		Max.		Base		Max.	
	lbs.	kg	lbs.	kg	lbs.	kg	lbs.	kg	lbs.	kg	lbs.	kg	lbs.	kg	lbs.	kg	in.	mm	in.	mm	in.	mm	in.	mm
092	293	133	338	153	263	119	295	134	286	130	316	143	326	148	370	168	46.5	1181	45.5	1156	24.5	622	25.5	648
102	294	134	340	154	265	120	297	135	288	131	318	144	328	149	372	169	46.5	1181	45.5	1156	24.5	622	25.5	648
120	306	139	349	158	275	125	305	138	295	134	326	148	334	152	382	173	46.5	1181	45.5	1156	24.5	622	25.5	648
150	316	143	359	163	284	129	314	142	304	138	393	178	345	157	393	178	46.5	1181	45.5	1156	24.5	622	25.5	648

Base Unit - The unit with NO INTERNAL OPTIONS.

Max. Unit - The unit with ALL INTERNAL OPTIONS Installed. (Economizer, Standard Static Power Exhaust Fans, Controls, etc.). Does not include accessories external to unit or high static power exhaust.

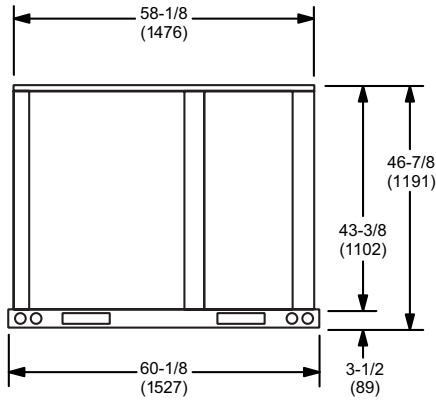
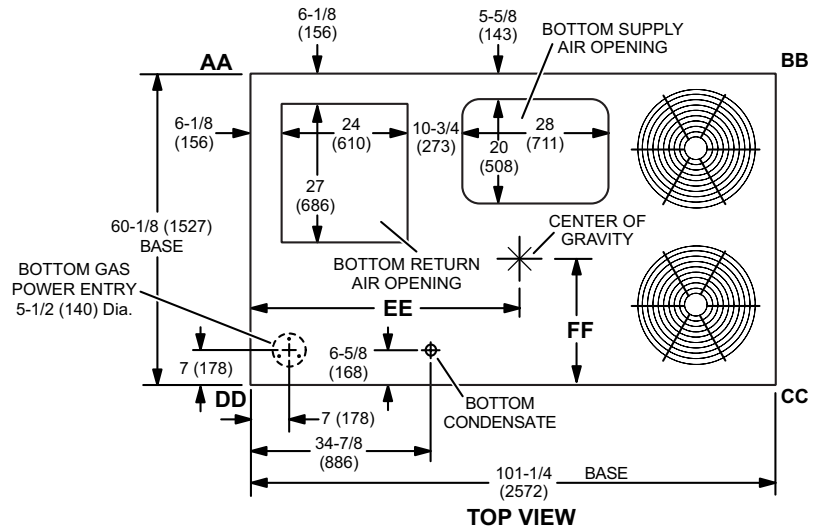

END VIEW

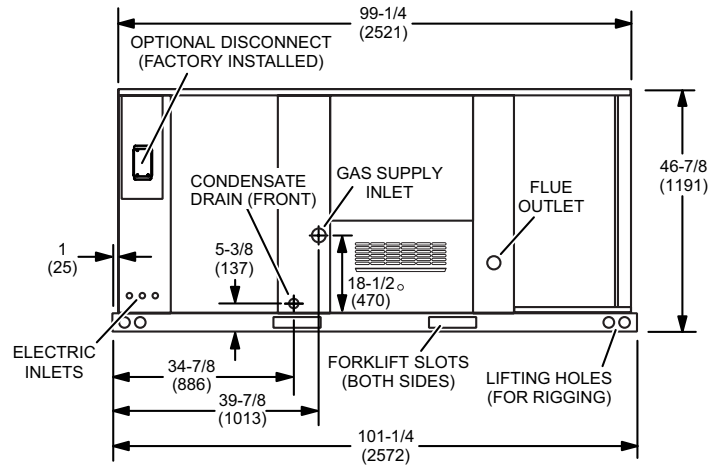

SIDE VIEW

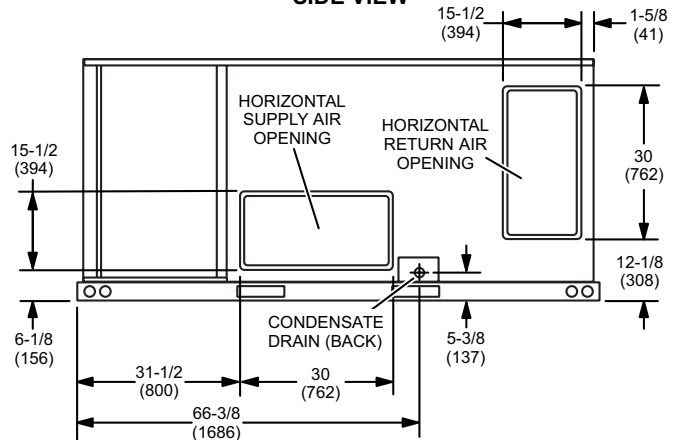

SIDE VIEW  
(Horizontal Openings)

### OUTDOOR AIR HOOD DETAIL

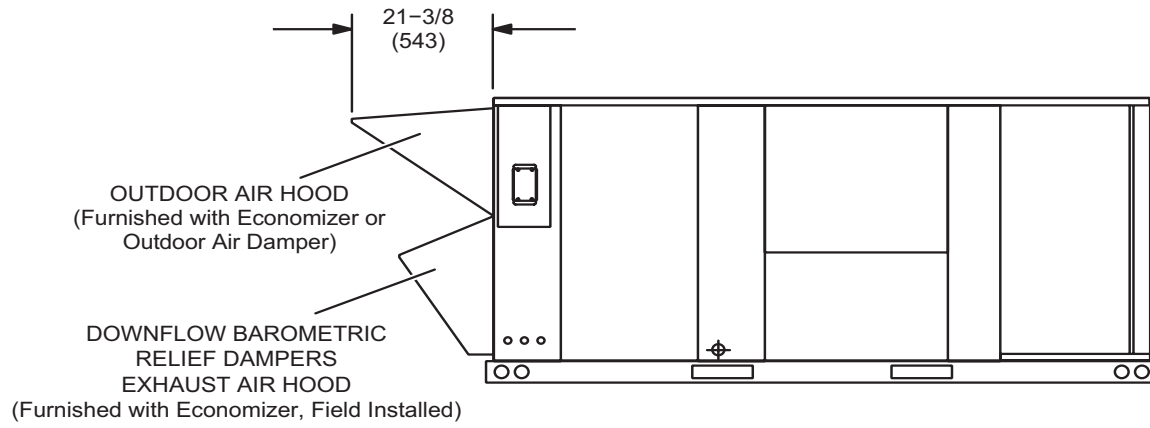



**HORIZONTAL ECONOMIZER APPLICATION  
(With Furnished Barometric Relief Dampers and Optional Horizontal Discharge Kit - Required)**

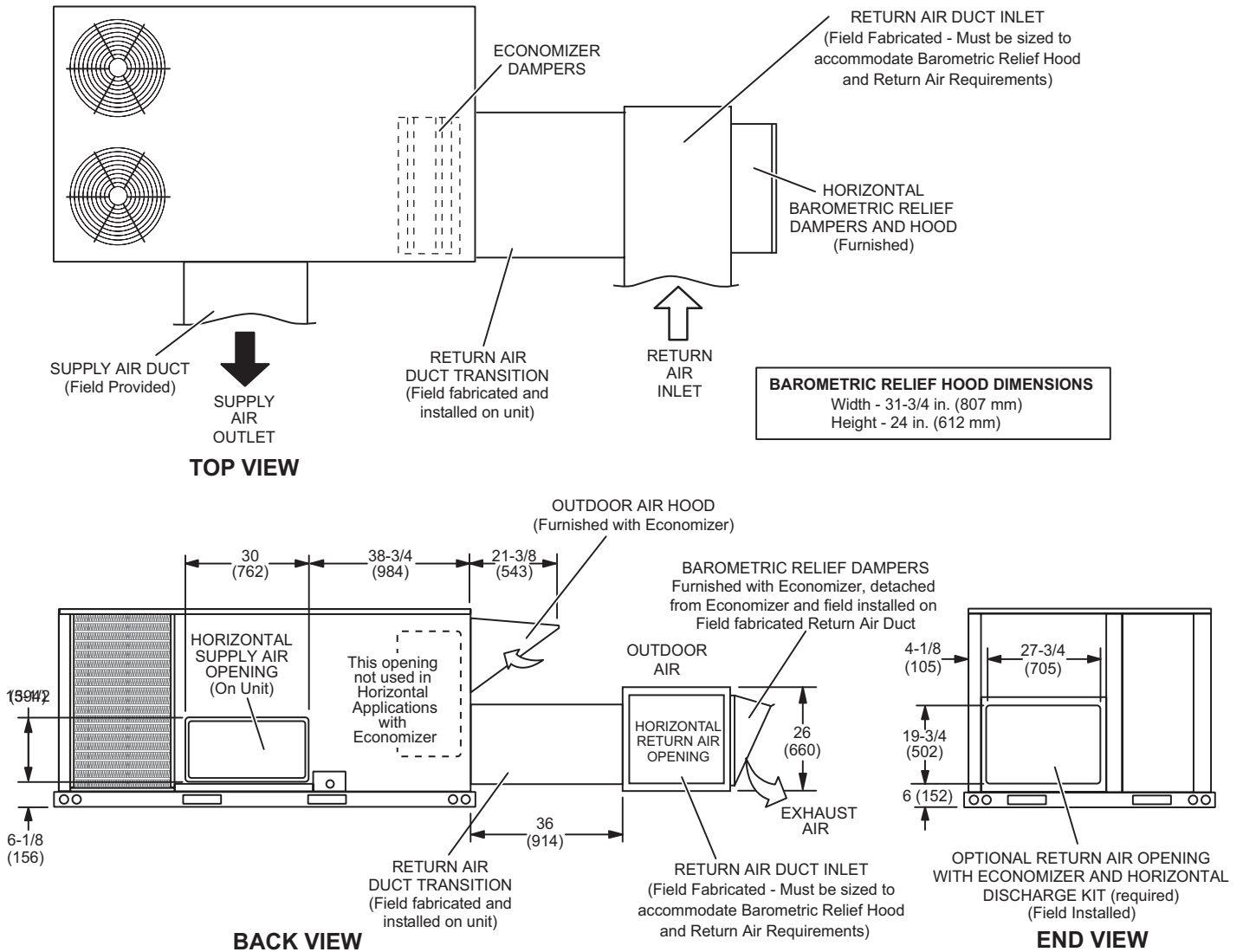

**NOTE** - Return Air Duct and Transition must be supported.

**BAROMETRIC RELIEF DAMPERS  
(Furnished with Economizer)**

(Field installed in horizontal return air duct adjacent to unit)

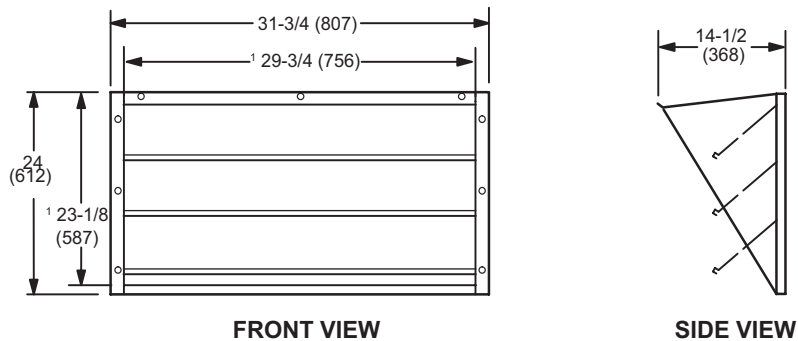

<sup>1</sup> NOTE - Opening size required in return air duct.

**HORIZONTAL ECONOMIZER APPLICATION**

(with Optional Low Profile Horizontal Barometric Relief Dampers and Horizontal Discharge Kit - Required)

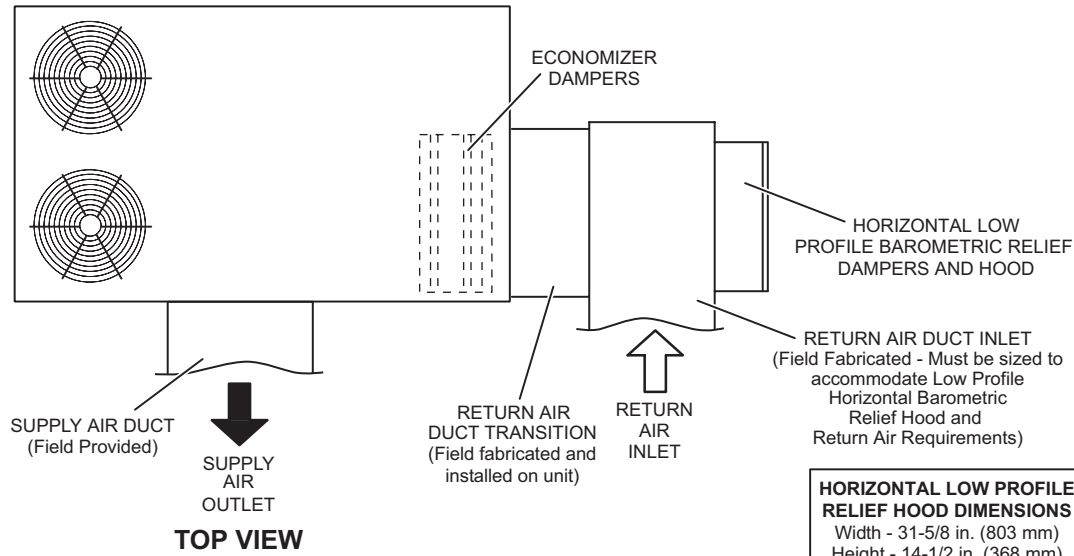

**TOP VIEW**

**HORIZONTAL LOW PROFILE RELIEF HOOD DIMENSIONS**  
 Width - 31-5/8 in. (803 mm)  
 Height - 14-1/2 in. (368 mm)

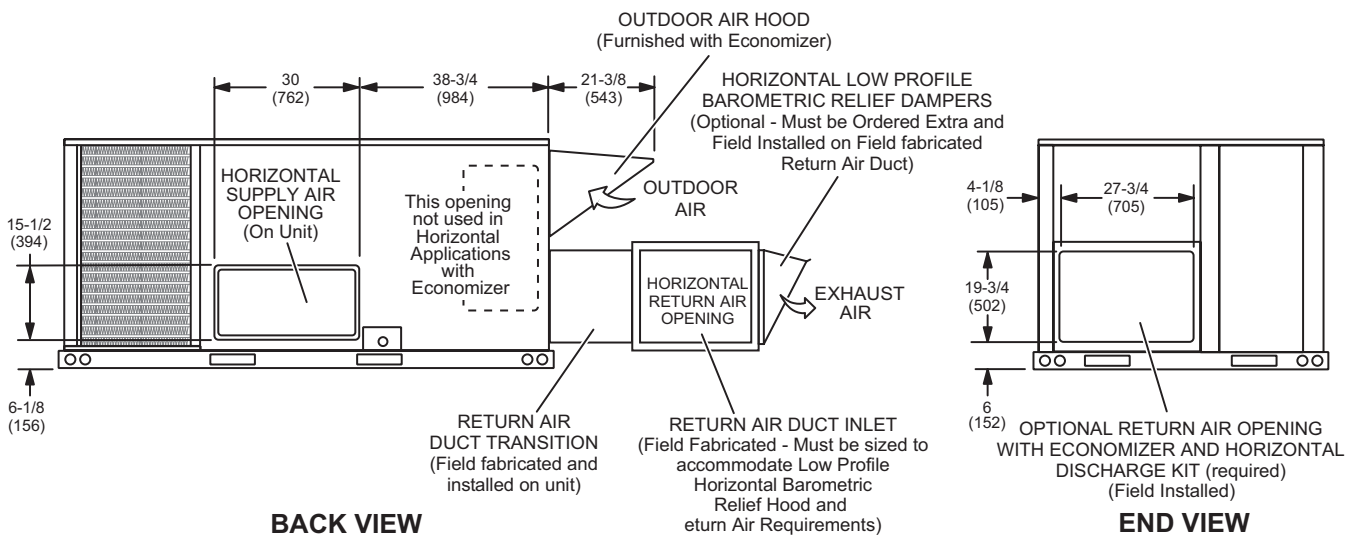

**BACK VIEW**

**END VIEW**

**NOTE** - Return Air Duct and Transition must be supported.

**HORIZONTAL LOW PROFILE BAROMETRIC RELIEF DAMPERS**  
 (Field installed in horizontal return air duct adjacent to unit)

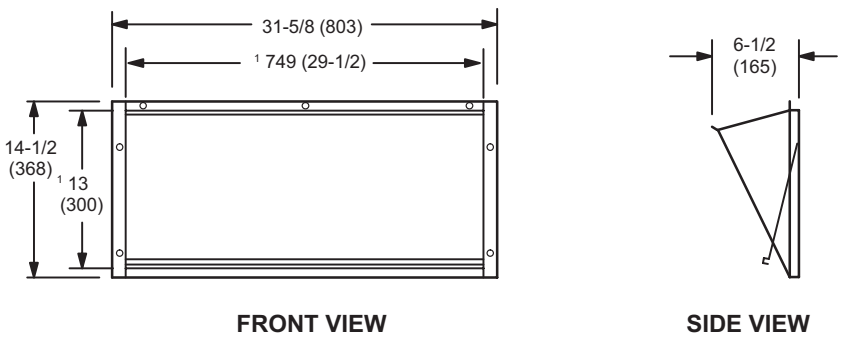

**FRONT VIEW**

**SIDE VIEW**

<sup>1</sup> NOTE - Opening size required in return air duct.

**HYBRID ROOF CURBS - DOUBLE DUCT OPENING**

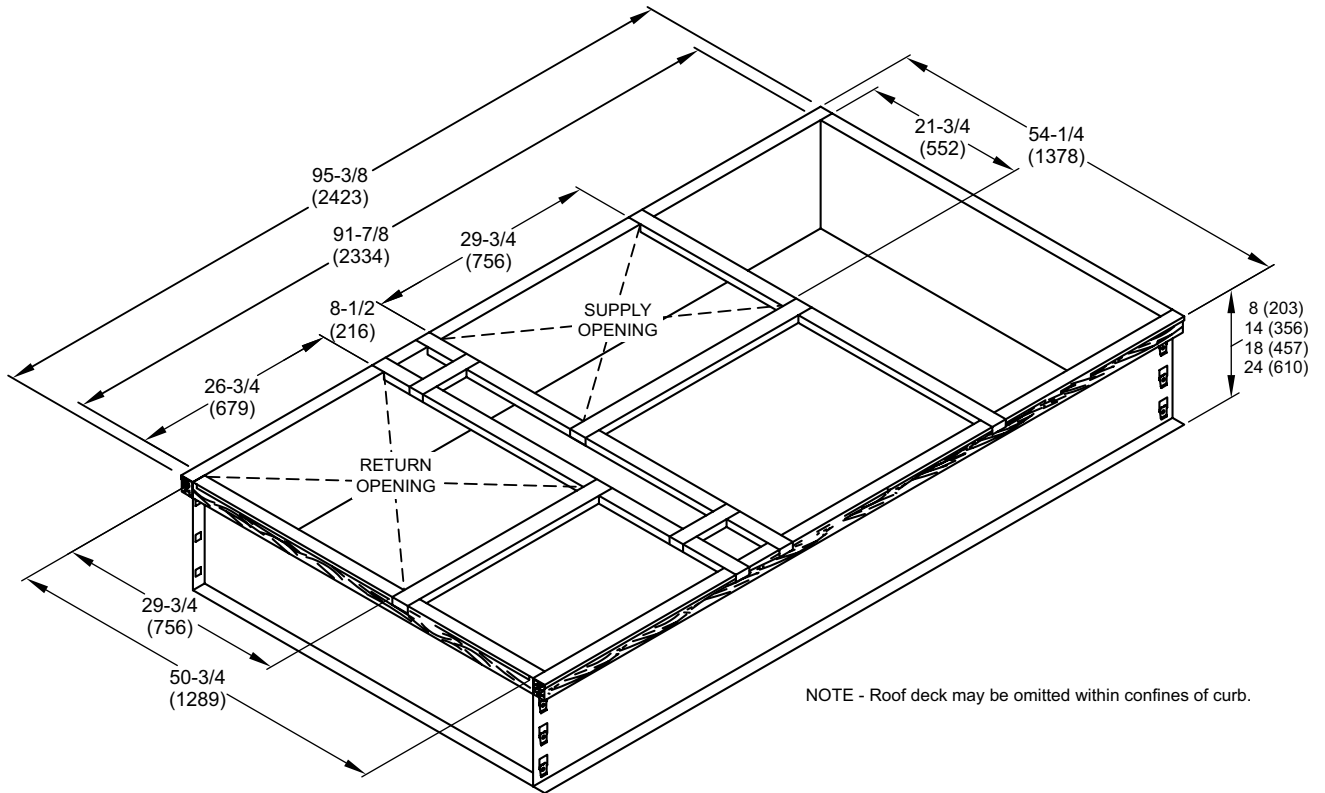

**TYPICAL FLASHING DETAIL FOR ROOF CURB**

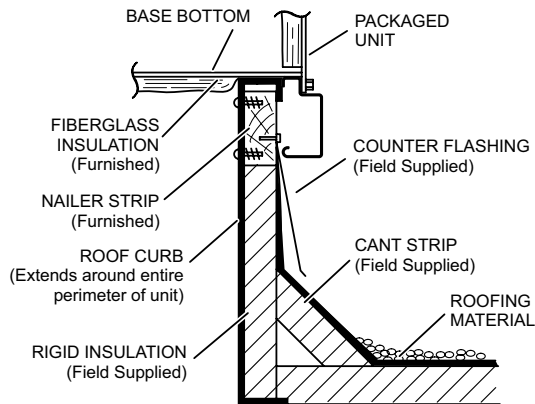

**DETAIL ROOF CURB**

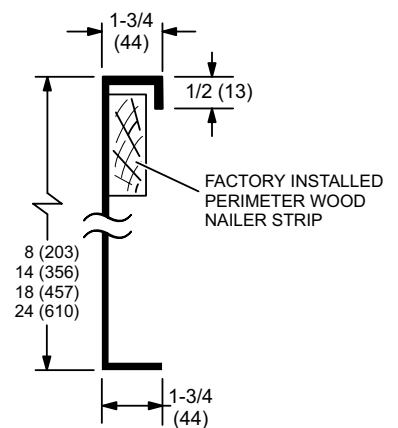

**ADJUSTABLE PITCH CURBS - DOUBLE DUCT OPENING**

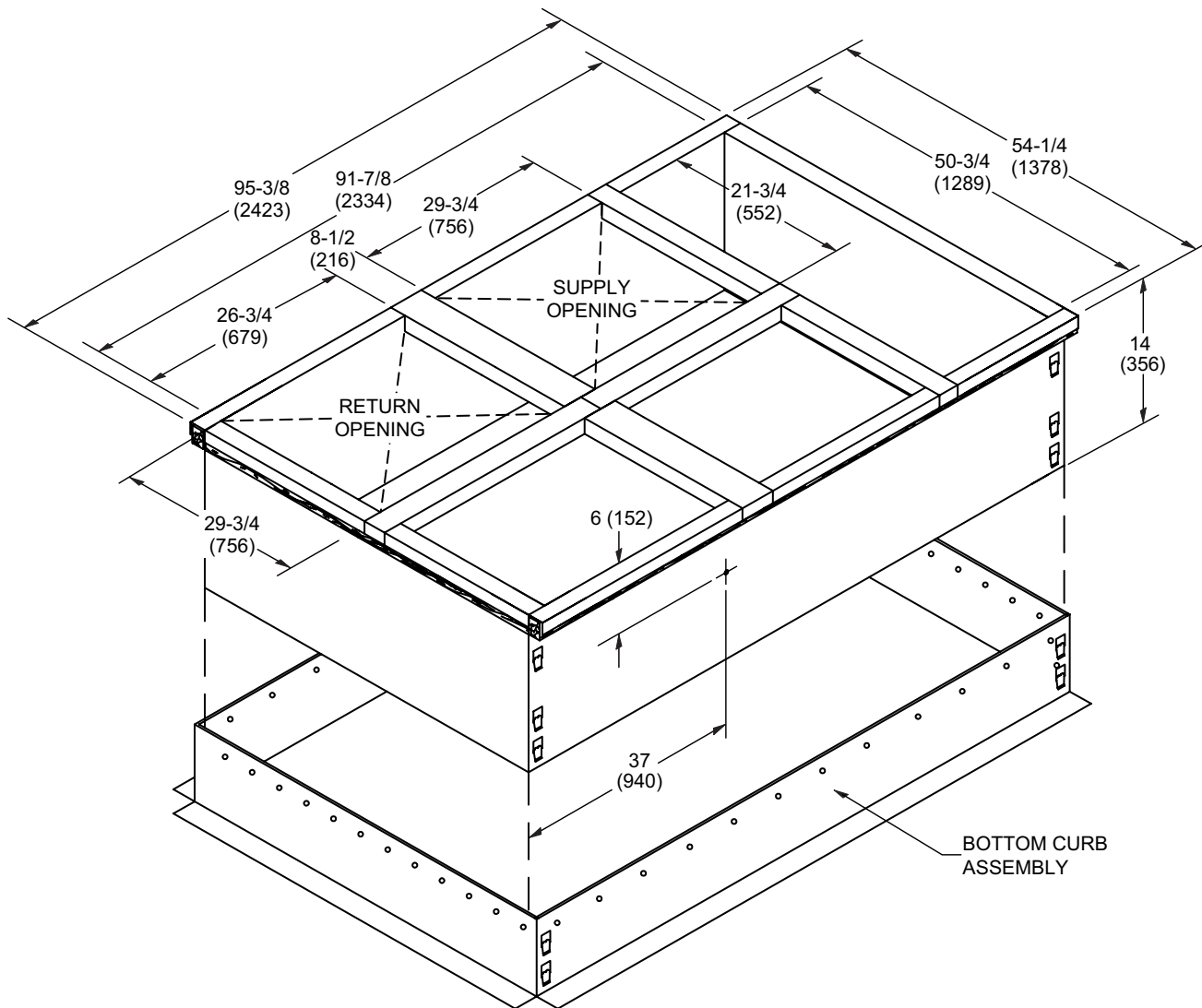

NOTE - Maximum slope pitch is 3/4 in. per 1 foot (19 mm per 305 mm) in any one direction.

**TYPICAL FLASHING DETAIL FOR ROOF CURB**

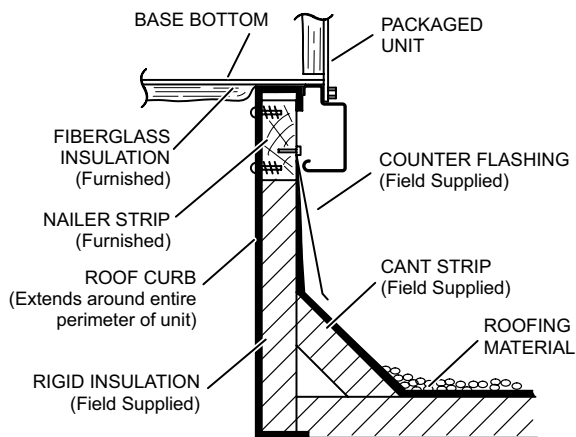

**DETAIL ROOF CURB**

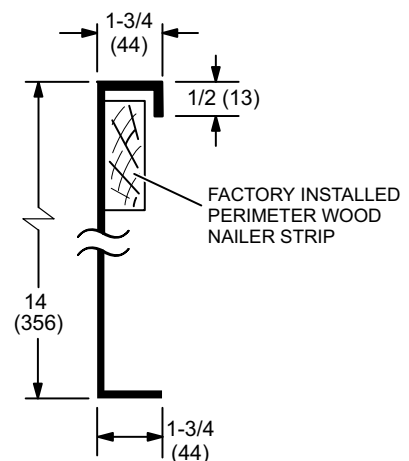

**ROOF CURBS WITH SUPPLY & RETURN AIR TRANSITIONS FOR CEILING DIFFUSERS**

**C1DIFF30B-1 ROUND TRANSITIONS**  
(for 092 models)

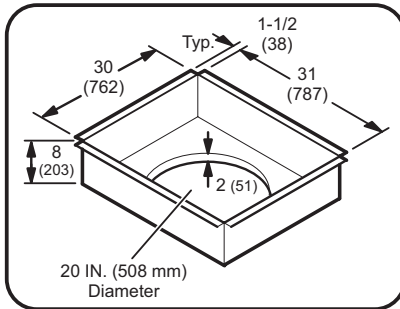

**C1DIFF31B-1 & C1DIFF32B-1 RECTANGULAR TRANSITIONS**  
(for 102 thru 150 models)

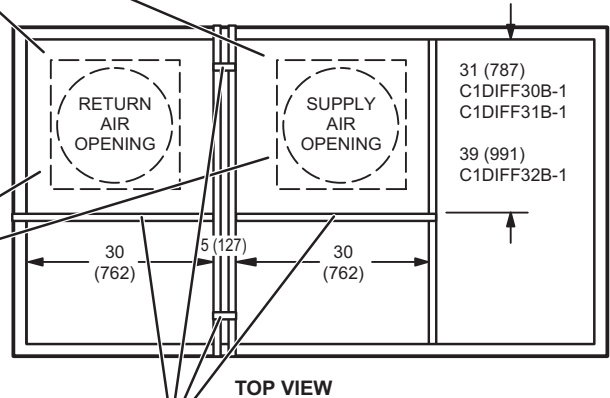
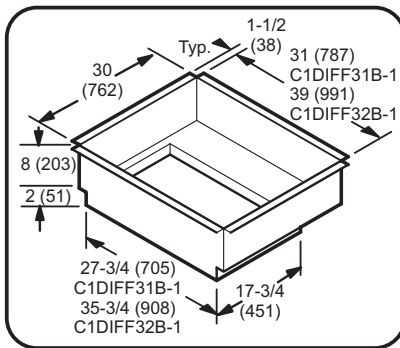

NOTE - These four supports are furnished with the transitions to replace supports furnished with curb for proper transition spacing.

**COMBINATION CEILING SUPPLY AND RETURN DIFFUSERS**

**STEP-DOWN CEILING DIFFUSER**

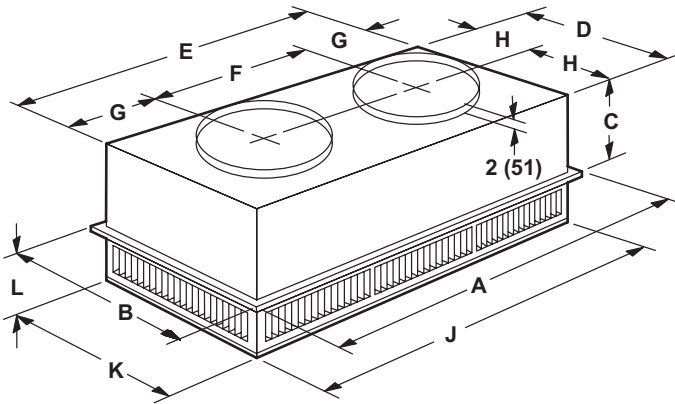

**FLUSH CEILING DIFFUSER**

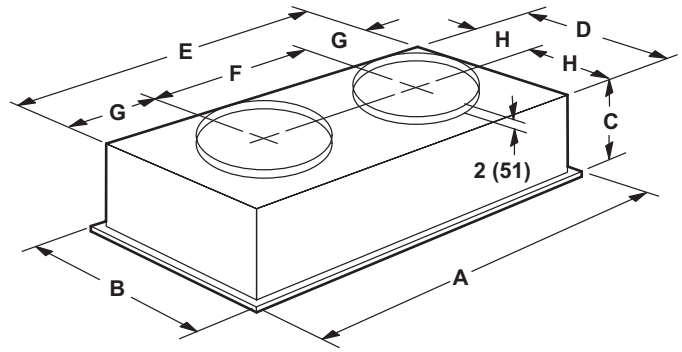

Model Number		RTD11-95S
A	in.	47-5/8
	mm	1159
B	in.	29-5/8
	mm	752
C	in.	14-3/8
	mm	365
D	in.	27-1/2
	mm	699
E	in.	45-1/2
	mm	1158
F	in.	22-1/2
	mm	572
G	in.	11-1/2
	mm	292
H	in.	13-3/4
	mm	349
J	in.	45-1/2
	mm	1156
K	in.	27-1/2
	mm	699
L	in.	8-1/8
	mm	206
Duct Size	in.	20 round
	mm	508 round

Model Number		FD11-95S
A	in.	47-5/8
	mm	1159
B	in.	29-5/8
	mm	752
C	in.	16-5/8
	mm	422
D	in.	27
	mm	686
E	in.	45
	mm	1143
F	in.	22-1/2
	mm	572
G	in.	11-1/4
	mm	286
H	in.	13-1/2
	mm	343
Duct Size	in.	20 round
	mm	508 round

**COMBINATION CEILING SUPPLY AND RETURN DIFFUSERS**

**STEP-DOWN CEILING DIFFUSER**

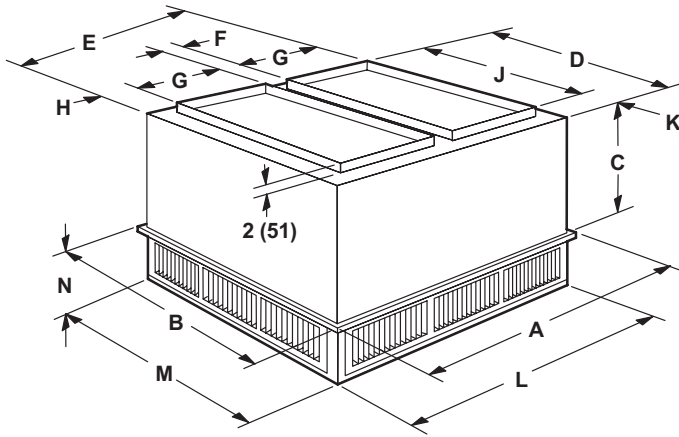

**FLUSH CEILING DIFFUSER**

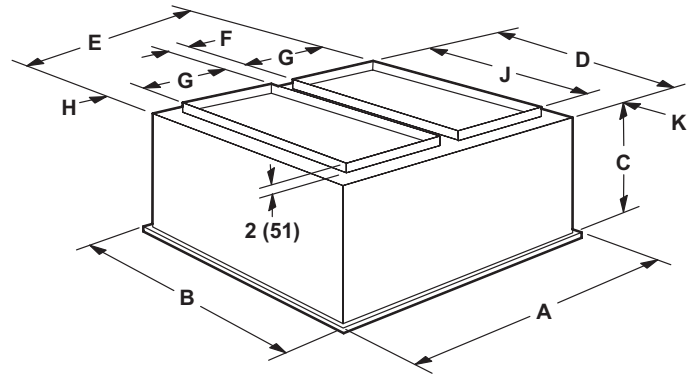

Model Number		RTD11-135S	RTD11-185S
<b>A</b>	in.	47-5/8	47-5/8
	mm	1210	1210
<b>B</b>	in.	35-5/8	47-5/8
	mm	905	1210
<b>C</b>	in.	20-5/8	24-5/8
	mm	524	625
<b>D</b>	in.	33-1/2	45-1/2
	mm	851	1156
<b>E</b>	in.	45-1/2	45-1/2
	mm	1156	1156
<b>F</b>	in.	4-1/2	4-1/2
	mm	114	114
<b>G</b>	in.	18	18
	mm	457	457
<b>H</b>	in.	2-1/2	2-1/2
	mm	64	64
<b>J</b>	in.	28	36
	mm	711	914
<b>K</b>	in.	2-3/4	4-3/4
	mm	70	121
<b>L</b>	in.	45-1/2	45-1/2
	mm	1156	1156
<b>M</b>	in.	33-1/2	45-1/2
	mm	851	1156
<b>N</b>	in.	9-1/8	10-1/8
	mm	232	257
<b>Duct Size</b>	in.	18 x 28	18 x 36
	mm	457 x 711	457 x 914

Model Number		FD11-135S	FD11-185S
<b>A</b>	in.	47-5/8	47-5/8
	mm	1210	1210
<b>B</b>	in.	35-5/8	47-5/8
	mm	905	1210
<b>C</b>	in.	23-1/4	29-1/4
	mm	591	743
<b>D</b>	in.	33	45
	mm	838	1143
<b>E</b>	in.	45	45
	mm	1143	1143
<b>F</b>	in.	4-1/2	4-1/2
	mm	114	114
<b>G</b>	in.	18	18
	mm	457	457
<b>H</b>	in.	2-1/4	2-1/4
	mm	57	57
<b>J</b>	in.	28	36
	mm	711	914
<b>K</b>	in.	2-1/2	4-1/2
	mm	64	114
<b>Duct Size</b>	in.	18 x 28	18 x 36
	mm	457 x 711	457 x 914

## REVISIONS

Sections	Description of Change
Options / Accessories	Updated Smoke Detector catalog numbers.



Visit us at [www.Lennox.com](http://www.Lennox.com)

For the latest technical information, [www.LennoxCommercial.com](http://www.LennoxCommercial.com)

Contact us at 1-800-4-LENNOX

NOTE - Due to Lennox' ongoing commitment to quality, Specifications, Ratings and Dimensions subject to change without notice and without incurring liability. Improper installation, adjustment, alteration, service or maintenance can cause property damage or personal injury. Installation and service must be performed by a qualified installer and servicing agency.

©2024 Lennox Industries, Inc.