

UNIT INFORMATION

LHT SERIES
3 to 6 ton

100125

Service Literature

High Efficiency LHT036 through 072 With R-454B

LHT036, 048, 060 and 072 are high efficiency packaged units equipped with variable speed direct drive blowers, a two-speed compressor, and a variable speed outdoor fan.

Optional electric heat is factory or field installed. Electric heat operates in single stage depending on the kW input size. 7.5 kW through 22.5 kW heat sections are available for the LHT unit.

Information contained in this manual is intended for use by qualified service technicians only. All specifications are subject to change. Procedures outlined in this manual are presented as a recommendation only and do not supersede or replace local or state codes.

If the unit must be lifted for service, rig unit by attaching four cables to the holes located in the unit base rail (two holes at each corner). Refer to the installation instructions for the proper rigging technique.

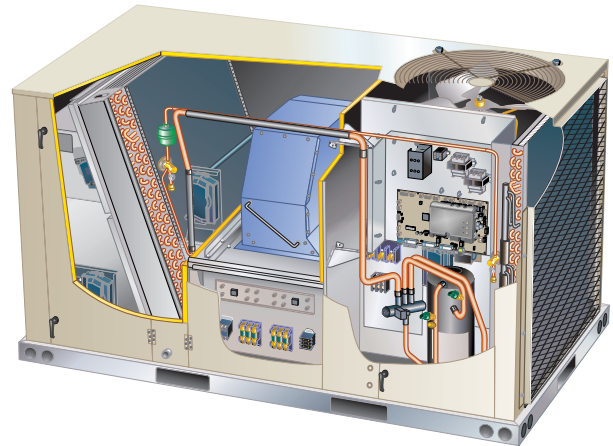

False ceilings or drop ceiling may be used as a return air plenum only if the unit being installed has a Refrigerant Detection System installed.

All maintenance staff and others working in the local area shall be instructed on the nature of work being carried out with work in confined spaces being avoided.

Ensure that the area is in the open or that it is adequately ventilated before breaking into the system or conducting any hot work. A degree of ventilation shall continue during the period that the work is carried out. The ventilation should safely disperse any released refrigerant and preferably expel it externally into the atmosphere.

⚠ WARNING

Do not use means to accelerate the defrosting process or to clean, other than those recommended by the manufacturer.

The appliance shall be stored in a room without continuously operating ignition sources (for example: open flames, an operating gas appliance, or an operating electric heater).

Do not pierce or burn.

Be aware that refrigerants may not contain an odor.

⚠ WARNING

If this appliance is conditioning a space with an area smaller than TA min or stored in a space with an area smaller than A min as defined by this instruction, then that space must be without continuously operating open flames (e.g. an operating gas appliance) or other potential ignition sources (e.g. an operating electric heater or similar hot surface). A flame-producing device may be installed in the same space if the device is provided with an effective flame arrest system.

⚠ WARNING

Auxiliary devices which may be potential ignition sources shall not be installed in the duct work. Examples of potential ignition sources are hot surfaces with a temperature exceeding 700°C and electric switching components.

Table of Contents

Options	Page 2
Specifications	Page 6
Blower Data	Page 7
Electrical / Electric Heat Data	Page 15
I Unit Components	Page 21
RDS	Page 9
II Placement and Installation	Page 33
III Start Up Operation	Page 33
IV Charging	Page 34
V System Service Checks	Page 36
VI Maintenance	Page 36
VII Accessories	Page 39
VIII Decommissioning	Page 44
IX Diagrams	Page 45

⚠ WARNING

To prevent serious injury or death:

- 1- Lock-out/tag-out before performing maintenance.
- 2- If system power is required (e.g., smoke detector maintenance), disable power to blower, remove fan belt where applicable, and ensure all controllers and thermostats are set to the "OFF" position before performing maintenance.
- 3- Always keep hands, hair, clothing, jewelry, tools, etc., away from moving parts.

⚠ WARNING

Only Manufacturer approved auxiliary devices are permitted to be installed in this unit.

⚠ CAUTION

Any service personnel installing, decommissioning, or performing maintenance on the unit must be properly trained with A2L refrigerants.

⚠ WARNING



Electric shock hazard. Can cause injury or death. Before attempting to perform any service or maintenance, turn the electrical power to unit OFF at disconnect switch(es). Unit may have multiple power supplies.

⚠ WARNING

Improper installation, adjustment, alteration, service or maintenance can cause property damage, personal injury or loss of life. Installation and service must be performed by a licensed professional HVAC installer or equivalent, service agency, or the gas supplier.

⚠ CAUTION

As with any mechanical equipment, contact with sharp sheet metal edges can result in personal injury. Take care while handling this equipment and wear gloves and protective clothing.

⚠ IMPORTANT

The Clean Air Act of 1990 bans the intentional venting of refrigerant (CFC's and HCFC's) as of July 1, 1992. Approved methods of recovery, recycling or reclaiming must be followed. Fines and/or incarceration may be levied for non-compliance.

⚠ WARNING

- This appliance must be installed in accordance with local and national wiring regulations.
- If the appliance is not fitted with an option for full disconnection from power, a means of disconnection must be incorporated in the fixed wiring in accordance with national and local wiring regulations.

OPTIONS / ACCESSORIES

Item	Order Number	Size				
		036	048	060	072	
COOLING SYSTEM						
Condensate Drain Trap	PVC	22H54	X	X	X	X
	Copper	76W27	X	X	X	X
Drain Pan Overflow Switch		21Z07	OX	OX	OX	OX
BLOWER - SUPPLY AIR						
Motors - Standard Static (All voltages)	Direct Drive ECM Blower - 0.50 HP	Factory	O			
	1.0 HP	Factory		O	O	
Motors - High Static (3 phase only)	DirectPlus™ Direct Drive ECM Blower System - 1.5 HP	Factory	O	O	O	O
CABINET						
Combination Coil/Hail Guards		13T03	OX	OX	OX	OX
Corrosion Protection		Factory	O	O	O	O
CONTROLS						
Blower Proving Switch		21Z10	OX	OX	OX	OX
Commercial Controls	LonTalk® Module	54W27	OX	OX	OX	OX
	Novar® LSE	Factory	O	O	O	O
Dirty Filter Switch		53W66	OX	OX	OX	OX
Fresh Air Tempering		21Z08	OX	OX	OX	OX
Smoke Detector - Supply or Return (Power board and one sensor)		21Z11	OX	OX	OX	OX
Smoke Detector - Supply and Return (Power board and two sensors)		21Z12	OX	OX	OX	OX
ELECTRICAL						
Voltage 60 Hz	208/230V - 1 phase	Factory	O	O	O	O
	208/230V - 3 phase	Factory	O	O	O	O
	460V - 3 phase	Factory	O	O	O	O
	575V - 3 phase	Factory	O	O	O	O
¹ HACR Circuit Breakers		Factory	O	O	O	O
¹ Disconnect Switch	80 amp	22A23	OX	OX	OX	OX
	150 amp	22A24	OX	OX	OX	OX
² Short-Circuit Current Rating (SCCR) of 100kA (includes Phase/Voltage Detection)		Factory	O	O	O	O
GFI Service Outlets	15 amp non-powered, field-wired (208/230V, 460V only)	74M70	OX	OX	OX	OX
	15 amp factory-wired and powered (208/230V, 460V)	Factory	O	O	O	O
	³ 20 amp non-powered, field-wired (208/230V, 460V, 575V)	67E01	X	X	X	X
	² 20 amp non-powered, field-wired (575V only)	Factory	O	O	O	O
Weatherproof Cover for GFI		10C89	X	X	X	X
Phase/Voltage Detection - 3 Phase Models Only		Factory	O	O	O	O

¹ HACR Circuit Breaker or Disconnect switch is required and must be ordered separately.

² Disconnect Switch not available with SCCR option.

SCCR option is only available with factory installed electric heat or no electric.

SCCR option is not available if the MOCP of the configured unit is greater than 200A.

³ Canada requires a minimum 20 amp circuit. Select 20 amp, non-powered, field wired GFI.

NOTE - Order Numbers shown are for ordering field installed accessories.

OX = Configure To Order (Factory Installed) or Field Installed.

O = Configure To Order (Factory Installed).

X = Field Installed.

OPTIONS / ACCESSORIES

Item	Order Number	Size				
		036	048	060	072	
ELECTRIC HEAT						
7.5 kW	208/240V-1ph	24U10	OX	OX	OX	
	208/240V-3ph	24U11	OX	OX	OX	OX
	460V-3ph	24U12	OX	OX	OX	OX
	575V-3ph	24U13	OX	OX	OX	OX
15 kW	208/240V-1ph	24U15	OX	OX	OX	
	208/240V-3ph	24U16	OX	OX	OX	OX
	460V-3ph	24U17	OX	OX	OX	OX
	575V-3ph	24U18	OX	OX	OX	OX
22.5 kW	208/240V-1ph	24U19			OX	
	208/240V-3ph	24U20			OX	OX
	460V-3ph	24U21			OX	OX
	575V-3ph	24U22			OX	OX

ECONOMIZER

High Performance Economizer With Outdoor Air Hood (Sensible Control) (Approved for California Title 24 Building Standards / AMCA Class 1A Certified)

High Performance Economizer - Includes Barometric Relief Dampers and Combination Hood	20H48	OX	OX	OX	OX
---	--------------	----	----	----	----

Economizer Accessories

Horizontal Economizer Conversion Kit	17W45	X	X	X	X
--------------------------------------	--------------	---	---	---	---

Economizer Controls (Not for Title 24)

Single Enthalpy	21Z09	OX	OX	OX	OX
Differential Enthalpy	Order 2 21Z09	OX	OX	OX	OX
Sensible Control	Sensor is Furnished Factory	O	O	O	O
Outdoor Air CFM Control	13J76	X	X	X	X
Global Control	Sensor Field Provided Factory	O	O	O	O
Building Pressure Control	13J77	X	X	X	X

POWER EXHAUST FAN (DOWNFLOW ONLY)

Standard Static	208/230V-1 or 3ph	21Z13	OX	OX	OX	OX
<i>NOTE - Factory or Field installed Power Exhaust Fan requires "Barometric Relief Dampers for Power Exhaust Kit (21Z21)" for field installation.</i>	460V-3ph	21Z14	OX	OX	OX	OX
	575V-3ph	21Z15	OX	OX	OX	OX

BAROMETRIC RELIEF

¹ Barometric Relief Dampers for Power Exhaust Kit	21Z21	X	X	X	X
² Horizontal Barometric Relief Dampers With Exhaust Hood	19F01	X	X	X	X

OUTDOOR AIR

Outdoor Air Dampers With Outdoor Air Hood

Motorized	15D17	OX	OX	OX	OX
Manual	15D18	X	X	X	X

¹ Required when Economizer is factory installed with factory installed Power Exhaust Fan option.

² Required when Economizer is configured for horizontal airflow.

NOTE - Order Numbers shown are for ordering field installed accessories.

OX = Configure To Order (Factory Installed) or Field Installed.

O = Configure To Order (Factory Installed).

X = Field Installed.

OPTIONS / ACCESSORIES

Item	Order Number	Size				
		036	048	060	072	
INDOOR AIR QUALITY						
Air Filters						
Healthy Climate® High Efficiency Air Filters 20 x 20 x 2 in.	MERV 8 (Order 4)	54W21	OX	OX	OX	OX
	MERV 13 (Order 4)	52W39	OX	OX	OX	OX
	MERV 16 (Order 4)	21U40	X	X	X	X
Replaceable Media Filter With Metal Mesh Frame (includes non-pleated filter media)	20 x 20 x 2 in. (Order 4)	44N60	X	X	X	X
Indoor Air Quality (CO₂) Sensors						
Sensor - Wall-mount, off-white plastic cover with LCD display		24C58	X	X	X	X
Sensor - Wall-mount, off-white plastic cover, no display		23V86	X	X	X	X
Sensor - Black plastic case, LCD display, rated for plenum mounting		87N52	X	X	X	X
Sensor - Black plastic case, no display, rated for plenum mounting		23V87	X	X	X	X
CO ₂ Sensor Duct Mounting Kit - for downflow applications		23Y47	X	X	X	X
Aspiration Box - for duct mounting non-plenum rated CO ₂ sensors (24C58)		90N43	X	X	X	X
Needlepoint Bipolar Ionization (NPBI)						
Needlepoint Bipolar Ionization (NPBI) Kit		22U14	X	X	X	X
UVC Germicidal Lamps						
¹ Healthy Climate® UVC Light Kit (110/230V-1ph)		21A92	X	X	X	X
Step-Down Transformers	460V primary, 230V secondary	10H20	X	X	X	X
	575V primary, 230V secondary	10H21	X	X	X	X
ROOF CURBS						
Hybrid Roof Curbs, Downflow						
8 in. height		11F50	X	X	X	X
14 in. height		11F51	X	X	X	X
18 in. height		11F52	X	X	X	X
24 in. height		11F53	X	X	X	X
Adjustable Pitched Curb						
14 in. height		42W27	X	X	X	X
Transition Curb						
Matches Enlight 036-072 Units to existing L Series® Curbs		31B05	X	X	X	X
CEILING DIFFUSERS						
Step-Down - Order one	RTD11-95S	13K61	X	X	X	X
Flush - Order one	FD11-95S	13K56	X	X	X	X
Transitions (Supply and Return) - Order one	T1TRAN20N-1	17W54	X	X	X	X

¹ Lamps operate on 110-230V single-phase power supply. Step-down transformer may be ordered separately for 460V and 575V units. Alternately, 110V power supply may be used to directly power the UVC ballast(s).

NOTE - Order Numbers shown are for ordering field installed accessories.

OX = Configure To Order (Factory Installed) or Field Installed.

O = Configure To Order (Factory Installed).

X = Field Installed.

SPECIFICATIONS

Model	LHT036H5E	LHT048H5E	LHT060H5E	LHT072H5E	
Nominal Tonnage	3	4	5	6	
Efficiency Type	High	High	High	High	
Blower Type	MSAV® ECM Direct Drive	MSAV® ECM Direct Drive	MSAV® ECM Direct Drive	MSAV® ECM Direct Drive	
Cooling Performance	Gross Cooling Capacity (Btuh)	38,000	46,800	60,000	
	¹ Net Cooling Capacity (Btuh)	35,500	44,500	57,000	
	¹ AHRI Rated Air Flow (cfm-high/low)	1400/935	1400/1100	1800/1300	
	¹ SEER2 (Btuh/Watt)	16.0	15.6	15.2	
	¹ EER2 (Btuh/Watt)	12.2	12.0	11.8	
	¹ IEER (Btuh/Watt)	---	---	---	
	¹ EER (Btuh/Watt)	---	---	---	
	Total Unit Power (kW)	2.9	3.7	4.7	
Heating Performance	¹ Total High Heating Capacity (Btuh)	34,000	44,000	57,000	
	¹ AHRI Rated Air Flow (cfm)	1400/935	1400/1100	1800/1300	
	¹ HSPF2 (Region IV)	7.20	7.20	7.20	
	¹ COP	3.5	3.5	3.5	
		Total Unit Power (kW)	2.8	3.7	4.8
	¹ Total Low Heating Capacity (Btuh)	19,000	25,000	33,000	
	¹ COP	2.1	2.1	2.2	
	Total Unit Power (kW)	2.7	3.3	4.2	
Sound Rating Number	dBA	75	75	82	
Refrigerant	Refrigerant Type	R-454B	R-454B	R-454B	
		13 lbs. 9 oz.	13 lbs. 15 oz.	16 lbs. 2 oz.	
Electric Heat Available	See Page 4				
Compressor Type (Number)	Two-Stage Scroll (1)				
Outdoor Coil	Net face area - ft. ²	19.3	19.3	19.3	
	Tube Diameter - in.	3/8	3/8	3/8	
	Rows	2	2	3	
	Fins - in.	20	20	20	
Outdoor Fan	Motor HP (number and type)	1/3 (1 ECM)	1/3 (1 ECM)	1/3 (1 ECM)	
	Rpm	850/575	850/700	945/725	
	Watts	70-240	140-240	140-310	
	Diameter (Number) - in.	(1) 24	(1) 24	(1) 24	
	Blades	3	3	3	
	Total air volume - cfm	4060/2740	4060/3330	4400/3550	
				4400	
Indoor Coil	Net face area - ft. ²	9.7	9.7	9.7	
	Tube Diameter - in.	3/8	3/8	3/8	
	Rows	3	3	4	
	Fins - in.	14	14	14	
	Condensate drain size (NPT) - in.	(1) 1	(1) 1	(1) 1	
	Expansion device type	Balanced Port Thermostatic Expansion Valve			
Indoor Blower	Standard Blower type	Direct Drive ECM		---	
	Static Blade type	Forward Curved		---	
	(All Voltages) Nominal motor HP	0.50	1	1	
	Wheel (Number) diameter x width - in.	(1) 10 X 10	(1) 11 X 10	(1) 11 X 10	
	High Blower type	DirectPlus™ Direct Drive ECM			
	Static Blade type	Backward Curved			
	(3ph Only) Nominal motor HP	1.5	1.5	1.5	
	Wheel (Number) diameter x width - in.	(1) 14 X 5	(1) 14 X 5	(1) 14 X 5	
Filters	Type	MERV 4, Disposable			
	Number and size - in.	(4) 20 x 20 x 2			
Line voltage data (Volts-Phase-Hz)		208/230-1-60 208/230-3-60 460-3-60 575-3-60		208/230-3-60 460-3-60 575-3-60	

NOTE - Net capacity includes evaporator blower motor heat deduction. Gross capacity does not include evaporator blower motor heat deduction.

¹ AHRI Certified to AHRI Standard 210/240 (3-5 ton) or 340/360 (6 ton):

Cooling Ratings - 95°F outdoor air temperature and 80°F db/67°F wb entering indoor coil air.

High Temperature Heating Ratings - 47°F db/43°F wb outdoor air temperature and 70°F entering indoor coil air.

Low Temperature Heating Ratings - 17°F db/15°F wb outdoor air temperature and 70°F entering indoor coil air.

BLOWER DATA

0.5 HP | 3 ROW (036)

BLOWER TABLE INCLUDES RESISTANCE FOR BASE UNIT ONLY WITH DRY INDOOR COIL AND AIR FILTERS IN PLACE.

FOR ALL UNITS ADD:

- 1 - Any factory installed options air resistance (heat section, economizer, etc.).
- 2 - Any field installed accessories air resistance (duct resistance, diffuser, etc.).

See Page 14 for wet coil and options/accessory air resistance data.

DOWNFLOW

External Static Press. in. w.g.	Percentage of Total Motor Torque																										
	20%			30%			40%			50%			60%			70%			80%			90%			100%		
	Cfm	RPM	Watts	Cfm	RPM	Watts	Cfm	RPM	Watts	Cfm	RPM	Watts	Cfm	RPM	Watts	Cfm	RPM	Watts	Cfm	RPM	Watts	Cfm	RPM	Watts	Cfm	RPM	Watts
0	819	47	403	1006	79	463	1192	111	523	1335	152	573	1477	193	622	1580	236	661	1682	279	699	1812	353	753	1876	400	783
0.1	723	48	485	919	82	539	1114	116	593	1264	159	637	1414	202	681	1522	246	715	1629	290	749	1767	365	797	1835	414	824
0.2	636	51	565	840	88	613	1044	124	660	1201	169	699	1357	213	738	1470	258	769	1582	303	799	1726	380	841	1797	429	865
0.3	557	57	641	769	96	683	981	134	725	1144	180	760	1306	226	794	1423	273	821	1540	319	848	1689	397	885	1761	446	906
0.4	485	65	713	704	106	750	923	146	787	1091	194	818	1259	241	848	1380	289	872	1500	336	895	1653	415	929	1725	463	948
0.5	418	73	783	644	116	815	870	158	846	1043	207	873	1215	256	900	1339	305	921	1462	353	942	1618	433	973	1689	481	991
0.6	355	82	849	587	127	876	819	171	903	996	222	927	1173	272	950	1299	321	969	1425	370	987	1582	451	1016	1651	499	1034
0.7	---	---	---	---	---	---	769	184	957	950	236	978	1131	287	998	1259	337	1015	1387	387	1032	1544	468	1058	1610	516	1077
0.8	---	---	---	---	---	---	720	195	1008	904	248	1026	1088	301	1044	1218	352	1060	1347	403	1075	1503	484	1101	1565	531	1121
0.9	---	---	---	---	---	---	670	206	1057	857	260	1073	1043	314	1088	1173	366	1102	1303	417	1116	1458	498	1142	---	---	---
1.0	---	---	---	---	---	---	617	214	1102	806	269	1116	994	324	1130	1125	376	1144	1255	428	1157	1406	510	1184	---	---	---
1.1	---	---	---	---	---	---	561	219	1145	751	276	1157	941	332	1169	1071	384	1183	1200	436	1196	1347	518	1225	---	---	---
1.2	---	---	---	---	---	---	500	221	1185	691	278	1196	881	335	1207	1010	388	1221	1139	441	1234	1280	522	1265	---	---	---
1.3	---	---	---	---	---	---	---	---	---	---	---	---	814	335	1242	942	388	1256	1069	441	1270	---	---	---	---	---	---
1.4	---	---	---	---	---	---	---	---	---	---	---	---	738	330	1276	864	384	1291	989	437	1305	---	---	---	---	---	---

HORIZONTAL

External Static Press. in. w.g.	Percentage of Total Motor Torque																												
	20%			30%			40%			50%			60%			70%			80%			90%			100%				
	Cfm	RPM	Watts	Cfm	RPM	Watts	Cfm	RPM	Watts	Cfm	RPM	Watts	Cfm	RPM	Watts	Cfm	RPM	Watts	Cfm	RPM	Watts	Cfm	RPM	Watts	Cfm	RPM	Watts	Cfm	RPM
0	794	45	388	970	76	454	1146	107	519	1281	149	575	1416	191	630	1522	110	678	1627	293	726	1715	351	768	1802	408	810		
0.1	709	44	460	895	78	519	1080	111	577	1223	155	627	1366	199	677	1477	251	721	1588	303	764	1681	362	804	1773	420	843		
0.2	630	46	531	855	82	583	1019	117	634	1169	163	679	1318	208	723	1435	262	763	1552	315	803	1648	375	841	1743	434	878		
0.3	556	51	602	759	88	646	961	125	690	1117	172	730	1273	219	769	1395	274	805	1516	328	841	1615	388	877	1714	448	912		
0.4	486	58	671	696	97	709	906	135	746	1068	184	781	1230	232	815	1356	288	848	1481	343	880	1582	403	914	1683	463	948		
0.5	420	66	740	637	107	771	854	147	802	1021	196	831	1188	245	860	1317	301	890	1446	357	919	1549	418	951	1652	478	983		
0.6	---	---	---	---	---	---	804	159	856	946	209	881	1147	259	905	1279	316	932	1410	372	958	1514	432	989	1618	492	1019		
0.7	---	---	---	---	---	---	756	172	910	932	223	930	1107	273	949	1241	330	973	1374	386	996	1478	446	1026	1582	506	1055		
0.8	---	---	---	---	---	---	709	185	962	888	236	978	1066	287	993	1201	344	1014	1336	400	1034	1440	460	1063	1544	519	1091		
0.9	---	---	---	---	---	---	663	197	1013	844	249	1025	1025	300	1036	1161	357	1054	1296	413	1072	1399	472	1100	1502	530	1127		
1.0	---	---	---	---	---	---	---	---	---	---	---	---	982	313	1078	1118	369	1094	1254	424	1109	1355	482	1136	1456	540	1163		
1.1	---	---	---	---	---	---	---	---	---	---	---	---	938	323	1119	1073	379	1133	1208	434	1146	1307	491	1172	1406	548	1198		
1.2	---	---	---	---	---	---	---	---	---	---	---	---	892	332	1158	1026	387	1170	1159	441	1182	1255	497	1208	1351	553	1233		
1.3	---	---	---	---	---	---	---	---	---	---	---	---	843	340	1197	975	393	1207	1106	446	1216	1198	501	1242	1290	555	1268		
1.4	---	---	---	---	---	---	---	---	---	---	---	---	790	344	1234	920	396	1242	1049	448	1250	1137	501	1276	1224	553	1302		

BLOWER DATA

BLOWER TABLE INCLUDES RESISTANCE FOR BASE UNIT ONLY WITH DRY INDOOR COIL AND AIR FILTERS IN PLACE.

1.0 HP | 3 ROW (048)

FOR ALL UNITS ADD:

- 1 - Any factory installed options air resistance (heat section, economizer, etc.).
- 2 - Any field installed accessories air resistance (duct resistance, diffuser, etc.).

See Page 14 for wet coil and options/accessory air resistance data. See Page 14 for minimum air volume with electric heat.

DOWNFLOW

External Static Press. in. w.g.	Percentage of Total Motor Torque																										
	20%			30%			40%			50%			60%			70%			80%			90%			100%		
	Cfm	Watts	RPM	Cfm	Watts	RPM	Cfm	Watts	RPM	Cfm	Watts	RPM	Cfm	Watts	RPM	Cfm	Watts	RPM	Cfm	Watts	RPM	Cfm	Watts	RPM	Cfm	Watts	RPM
0	1115	124	488	1344	200	572	1573	276	655	1747	377	724	1920	477	792	2041	581	844	896	2304	852	964	2354	936	992		
0.1	1012	101	536	1253	181	614	1493	261	691	1677	366	755	1860	471	819	1990	578	868	916	2277	860	980	2339	951	1006		
0.2	926	88	584	1177	172	656	1427	256	728	1619	365	788	1811	473	848	1949	583	894	939	2256	873	999	2328	969	1024		
0.3	854	86	634	1113	173	701	1372	260	767	1572	371	823	1772	482	878	1916	595	921	2059	707	963	2240	891	1019	991	1043	
0.4	794	91	684	1061	181	746	1328	270	807	1535	383	859	1741	496	910	1890	611	950	2038	725	989	2226	913	1042	1014	1065	
0.5	745	104	734	1019	195	791	1292	286	847	1504	401	895	1715	515	942	1868	631	979	2020	747	1016	2214	936	1066	1039	1089	
0.6	704	122	785	983	215	837	1262	307	888	1478	423	932	1693	538	976	1849	654	1011	2004	770	1045	2201	960	1092	1063	1114	
0.7	671	145	836	954	238	883	1237	331	929	1456	447	969	1674	562	1009	1831	678	1041	1988	794	1073	2185	983	1118	1085	1140	
0.8	643	171	886	929	264	928	1215	357	969	1435	472	1006	1655	587	1043	1813	703	1073	1970	818	1103	2164	1005	1145	1104	1168	
0.9	619	199	935	907	291	973	1194	383	1010	1415	498	1043	1635	612	1076	1792	726	1104	1948	840	1132	2138	1024	1173	1212	1196	
1.0	596	228	983	884	319	1016	1172	410	1049	1392	523	1079	1612	635	1109	1766	747	1135	1920	859	1161	2104	1038	1200	1119	1196	
1.1	---	---	---	---	---	---	---	---	---	---	---	---	---	---	---	---	---	---	---	---	---	---	---	---	---	---	---
1.2	---	---	---	---	---	---	---	---	---	---	---	---	---	---	---	---	---	---	---	---	---	---	---	---	---	---	---
1.3	---	---	---	---	---	---	---	---	---	---	---	---	---	---	---	---	---	---	---	---	---	---	---	---	---	---	---
1.4	---	---	---	---	---	---	---	---	---	---	---	---	---	---	---	---	---	---	---	---	---	---	---	---	---	---	---

HORIZONTAL

External Static Press. in. w.g.	Percentage of Total Motor Torque																											
	20%			30%			40%			50%			60%			70%			80%			90%			100%			
	Cfm	Watts	RPM	Cfm	Watts	RPM	Cfm	Watts	RPM	Cfm	Watts	RPM	Cfm	Watts	RPM	Cfm	Watts	RPM	Cfm	Watts	RPM	Cfm	Watts	RPM	Cfm	Watts	RPM	
0	1087	111	493	1304	184	579	1520	257	665	1689	368	738	1857	478	810	1972	588	864	2087	698	918	2196	844	975	2283	925	1000	
0.1	1021	104	537	1246	180	618	1470	255	699	1646	368	768	1821	480	837	1941	592	888	2061	704	938	2179	852	992	2255	926	1017	
0.2	961	102	582	1193	181	658	1425	259	734	1607	373	799	1789	487	864	1914	601	912	2039	714	960	2163	864	1012	2231	932	1034	
0.3	906	106	628	1145	186	699	1384	266	769	1572	382	831	1759	498	892	1889	613	938	2018	728	984	2149	879	1033	2209	941	1053	
0.4	855	113	674	1101	196	740	1347	278	806	1540	396	864	1732	513	921	1866	629	965	1999	744	1008	2134	896	1054	---	---	---	
0.5	808	125	720	1060	209	781	1312	293	842	1509	412	896	1706	530	950	1843	646	992	1980	762	1033	2119	915	1077	---	---	---	
0.6	764	139	766	1022	225	823	1279	310	879	1481	430	930	1682	549	980	1821	666	1019	1960	782	1058	2102	935	1101	---	---	---	
0.7	722	155	812	985	242	864	1247	328	916	1452	449	964	1657	569	1011	1799	686	1048	1940	803	1084	2084	955	1125	---	---	---	
0.8	682	172	858	949	260	906	1216	348	953	1424	469	997	1632	589	1041	1776	706	1076	1919	823	1111	2063	974	1150	---	---	---	
0.9	643	191	903	914	279	946	1185	367	989	1396	489	1030	1606	610	1071	1751	727	1104	1895	843	1137	2039	992	1175	---	---	---	
1.0	---	---	---	---	---	---	---	---	---	---	---	---	---	---	---	---	---	---	---	---	---	---	---	---	---	---	---	---
1.1	---	---	---	---	---	---	---	---	---	---	---	---	---	---	---	---	---	---	---	---	---	---	---	---	---	---	---	---
1.2	---	---	---	---	---	---	---	---	---	---	---	---	---	---	---	---	---	---	---	---	---	---	---	---	---	---	---	---
1.3	---	---	---	---	---	---	---	---	---	---	---	---	---	---	---	---	---	---	---	---	---	---	---	---	---	---	---	---
1.4	---	---	---	---	---	---	---	---	---	---	---	---	---	---	---	---	---	---	---	---	---	---	---	---	---	---	---	---

BLOWER DATA

BLOWER TABLE INCLUDES RESISTANCE FOR BASE UNIT ONLY WITH DRY INDOOR COIL AND AIR FILTERS IN PLACE.

1.0 HP | 4 ROW (060)

FOR ALL UNITS ADD:

- 1 - Any factory installed options air resistance (heat section, economizer, etc.).
- 2 - Any field installed accessories air resistance (duct resistance, diffuser, etc.).

See Page 14 for wet coil and options/accessory air resistance data. See Page 14 for minimum air volume with electric heat.

DOWNFLOW

External Static Press. in. w.g.	Percentage of Total Motor Torque																												
	20%			30%			40%			50%			60%			70%			80%			90%			100%				
	Cfm	RPM	Watts	Cfm	RPM	Watts	Cfm	RPM	Watts	Cfm	RPM	Watts	Cfm	RPM	Watts	Cfm	RPM	Watts	Cfm	RPM	Watts	Cfm	RPM	Watts	Cfm	RPM	Watts	Cfm	RPM
0	1101	120	494	1328	196	578	1555	272	662	1728	374	731	1901	475	800	2023	580	852	2145	684	903	2292	854	970	2348	942	998		
0.1	1002	99	541	1241	180	620	1479	260	698	1662	366	763	1845	471	827	1976	579	876	2106	687	924	2268	865	987	2334	958	1013		
0.2	918	88	589	1167	173	663	1416	257	736	1608	366	796	1800	475	856	1938	586	902	2076	697	947	2249	880	1006	2324	978	1031		
0.3	848	86	638	1106	174	706	1364	261	774	1564	373	830	1763	485	886	1907	599	929	2051	712	972	2234	899	1028	2316	1000	1052		
0.4	790	92	688	1056	183	751	1321	273	814	1527	387	866	1733	501	918	1882	617	958	2031	732	998	2221	921	1051	2307	1024	1074		
0.5	742	105	738	1015	197	796	1287	289	854	1498	405	902	1709	520	950	1862	637	988	2014	754	1025	2208	944	1076	2296	1048	1099		
0.6	703	124	788	981	217	841	1258	310	894	1473	427	939	1688	543	984	1843	660	1019	1998	777	1053	2194	968	1101	2281	1071	1124		
0.7	670	146	838	952	240	887	1233	334	935	1451	451	976	1669	568	1017	1826	685	1050	1982	801	1082	2177	991	1128	2260	1092	1151		
0.8	642	172	888	927	266	932	1211	360	975	1431	477	1013	1650	593	1051	1807	709	1081	1963	825	1111	2155	1012	1155	2233	1109	1178		
0.9	618	200	937	904	294	976	1190	387	1015	1410	502	1050	1629	617	1084	1785	732	1112	1940	846	1140	2127	1029	1182	---	---	---		
1.0	595	229	985	882	321	1020	1168	413	1054	1387	526	1086	1605	639	1117	1758	752	1143	1911	864	1169	2090	1042	1209	---	---	---		
1.1	---	---	---	---	---	---	1144	437	1092	1360	548	1120	1576	659	1148	1725	769	1173	1874	878	1197	2043	1049	1236	---	---	---		
1.2	---	---	---	---	---	---	1115	458	1129	1328	566	1154	1540	674	1179	1685	780	1202	1829	886	1225	1985	1049	1262	---	---	---		
1.3	---	---	---	---	---	---	1080	475	1163	1288	579	1186	1496	683	1208	1634	785	1230	1772	887	1251	1913	1042	1288	---	---	---		
1.4	---	---	---	---	---	---	1037	487	1196	1239	587	1216	1441	686	1236	1572	783	1256	1703	880	1275	1826	1024	1312	---	---	---		

HORIZONTAL

External Static Press. in. w.g.	Percentage of Total Motor Torque																												
	20%			30%			40%			50%			60%			70%			80%			90%			100%				
	Cfm	RPM	Watts	Cfm	RPM	Watts	Cfm	RPM	Watts	Cfm	RPM	Watts	Cfm	RPM	Watts	Cfm	RPM	Watts	Cfm	RPM	Watts	Cfm	RPM	Watts	Cfm	RPM	Watts	Cfm	RPM
0	1077	113	502	1282	175	585	1486	237	668	1670	363	746	1854	489	823	1993	623	884	2131	757	944	2216	882	995	2268	926	1009		
0.1	1016	109	546	1227	172	624	1437	234	701	1626	361	775	1814	488	848	1956	623	906	2098	757	964	2194	887	1011	2242	928	1026		
0.2	962	111	591	1177	174	663	1392	236	735	1585	364	805	1777	492	874	1923	627	930	2069	762	985	2175	895	1029	2218	935	1044		
0.3	913	118	636	1133	181	703	1352	244	770	1548	372	836	1744	500	902	1893	636	955	2042	772	1007	2157	907	1048	2196	945	1063		
0.4	868	130	682	1092	193	744	1315	256	806	1515	384	868	1714	512	930	1866	648	980	2018	784	1030	2139	922	1069	---	---	---		
0.5	827	146	728	1054	209	785	1281	271	842	1484	399	901	1687	526	959	1841	663	1007	1995	799	1054	2121	938	1090	---	---	---		
0.6	789	165	775	1019	227	827	1249	288	879	1455	416	934	1660	543	988	1816	679	1034	1972	815	1079	2102	955	1113	---	---	---		
0.7	752	185	821	986	247	869	1219	308	916	1427	435	967	1634	562	1018	1792	698	1061	1949	833	1104	2081	972	1136	---	---	---		
0.8	718	208	867	954	268	910	1189	328	953	1399	455	1000	1608	581	1047	1767	716	1088	1925	851	1129	2058	989	1160	---	---	---		
0.9	684	231	913	922	290	951	1160	349	989	1371	475	1033	1581	600	1077	1741	734	1116	1900	868	1154	2031	1004	1185	---	---	---		
1.0	---	---	---	---	---	---	1129	369	1025	1341	494	1066	1553	618	1106	1713	751	1143	1872	884	1179	2001	1017	1209	---	---	---		
1.1	---	---	---	---	---	---	1097	388	1060	1310	511	1098	1522	634	1135	1682	766	1170	1841	898	1204	1966	1028	1233	---	---	---		
1.2	---	---	---	---	---	---	1063	405	1095	1276	527	1129	1488	648	1163	1647	779	1196	1806	909	1228	1925	1034	1257	---	---	---		
1.3	---	---	---	---	---	---	1026	420	1128	1239	540	1159	1451	659	1190	1609	788	1221	1767	917	1252	1879	1036	1281	---	---	---		
1.4	---	---	---	---	---	---	985	431	1160	1197	548	1188	1409	665	1216	1566	793	1245	1723	920	1274	1825	1033	1304	---	---	---		

BLOWER DATA

1.5 HP | 3 ROW (036, 048)

BLOWER TABLE INCLUDES RESISTANCE FOR BASE UNIT ONLY WITH DRY INDOOR COIL AND AIR FILTERS IN PLACE.

FOR ALL UNITS ADD:

- 1 - Any factory installed options air resistance (heat section, economizer, etc.).
- 2 - Any field installed accessories air resistance (duct resistance, diffuser, etc.).

See Page 14 for wet coil and options/accessory air resistance data. See Page 14 for minimum air volume with electric heat.

DOWNFLOW

Total Air cfm	Total Static Pressure - in. w.g.																											
	0.1		0.2		0.3		0.4		0.5		0.6		0.7		0.8		0.9		1.0		1.1		1.2		1.3			
	RPM	Watts	RPM	Watts	RPM	Watts	RPM	Watts	RPM	Watts	RPM	Watts	RPM	Watts	RPM	Watts	RPM	Watts	RPM	Watts	RPM	Watts	RPM	Watts	RPM	Watts	RPM	Watts
400	718	19	803	41	878	60	1080	111	1149	127	1226	129	1307	126	1386	124	1510	181	1574	197	1630	220	1681	250	1731	279	1779	307
600	845	50	929	72	1008	92	1214	143	1286	160	1362	168	1439	173	1510	181	1642	239	1697	263	1747	293	1796	324	1844	353	1890	379
800	971	79	1057	101	1138	123	1214	143	1286	160	1362	168	1439	173	1510	181	1642	239	1697	263	1747	293	1796	324	1844	353	1890	379
1000	1136	113	1215	135	1293	157	1367	177	1438	196	1510	209	1579	222	1642	239	1697	263	1747	293	1796	324	1844	353	1890	379	397	425
1200	1335	151	1406	172	1476	193	1544	213	1611	232	1675	250	1735	272	1788	299	1834	332	1878	368	1923	400	1970	428	2015	454	482	510
1400	1560	177	1617	204	1675	231	1732	257	1788	283	1841	310	1891	339	1936	371	1978	405	2019	439	2063	469	2108	496	2152	522	550	578
1600	1742	245	1792	278	1842	311	1892	344	1940	376	1988	406	2035	434	2080	461	2125	486	2169	513	2213	541	2256	570	2297	601	629	657
1800	1922	330	1970	363	2017	395	2064	426	2110	457	2155	485	2200	512	2244	539	2287	568	2328	600	2369	634	2408	671	2447	708	736	764
2000	2112	405	2158	438	2202	471	2246	503	2289	536	2331	568	2373	602	2413	640	2452	681	2490	723	2527	766	2564	809	2599	851	893	935
2200	2305	493	2347	531	2389	569	2429	608	2469	648	2508	691	2546	737	2582	784	2619	832	2654	878	2690	923	2724	965	2758	3007	3051	3095
2400	2499	617	2539	660	2578	704	2615	748	2652	794	2688	841	2722	890	2757	939	2791	986	2825	1031	2858	1075	2891	1117	2923	3171	3215	3259
2600	2697	773	2733	818	2769	864	2803	911	2837	957	2871	1005	2903	1052	2936	1099	2968	1143	3000	1186	3031	1228	3062	1270	3092	3340	3384	3428
2800	2896	944	2929	990	2962	1036	2993	1082	3025	1128	3056	1173	3087	1216	3118	1259	3147	1300	3177	1341	3206	1382	3236	1423	3264	3512	3556	3600
3000	3093	1115	3124	1160	3154	1205	3184	1249	3214	1293	3243	1335	3272	1376	3300	1416	3327	1456	3355	1495	3383	1536	3410	1576	3437	3685	3729	3773

Total Static Pressure - in. w.g.

Total Air cfm	Total Static Pressure - in. w.g.													
	1.4		1.5		1.6		1.7		1.8		1.9		2.0	
	RPM	Watts	RPM	Watts	RPM	Watts	RPM	Watts	RPM	Watts	RPM	Watts	RPM	Watts
800	1826	333	1979	424	2021	444	2064	464	2106	485	2149	509	2191	533
1000	1935	403	2100	498	2142	518	2184	541	2226	565	2267	592	2308	619
1200	2058	476	2235	574	2275	601	2316	629	2356	658	2395	689	2433	720
1400	2194	548	2377	665	2415	698	2453	733	2490	768	2527	803	2563	839
1600	2337	632	2521	785	2557	824	2592	863	2627	902	2661	942	2695	981
1800	2484	746	2668	935	2701	977	2735	1018	2768	1058	2802	1099	2834	1139
2000	2634	894	2823	1090	2855	1130	2887	1170	2919	1210	2952	1250	2984	1289
2200	2790	1049	2986	1240	3017	1280	3048	1320	3080	1360	3111	1399	3142	1437
2400	2954	1200	3153	1391	3184	1431	3215	1470	3245	1509	3276	1548	3306	1586
2600	3123	1351	3323	1542	3352	1580	3382	1619	3412	1658	3442	1696	3472	1734
2800	3294	1502	3492	1691	3520	1729	3549	1767	3578	1805	3608	1844	3638	1882
3000	3464	1653												

BLOWER DATA

1.5 HP | 3 ROW (036, 048)

BLOWER TABLE INCLUDES RESISTANCE FOR BASE UNIT ONLY WITH DRY INDOOR COIL AND AIR FILTERS IN PLACE.

FOR ALL UNITS ADD:

1 - Any factory installed options air resistance (heat section, economizer, etc.).

2 - Any field installed accessories air resistance (duct resistance, diffuser, etc.).

See Page 14 for wet coil and options/accessory air resistance data. See Page 14 for minimum air volume with electric heat.

HORIZONTAL

Total Air cfm	Total Static Pressure - in. w.g.																										
	0.1		0.2		0.3		0.4		0.5		0.6		0.7		0.8		0.9		1.0		1.1		1.2		1.3		
	RPM	Watts	RPM	Watts	RPM	Watts	RPM	Watts	RPM	Watts	RPM	Watts	RPM	Watts	RPM	Watts	RPM	Watts	RPM	Watts	RPM	Watts	RPM	Watts	RPM	Watts	
400	708	16	793	37	872	53	955	71	1034	89	1153	107	1272	125	1391	143	1510	161	1629	179	1748	197	1827	215	1916	233	2005
600	835	46	918	65	1000	82	1077	95	1149	107	1221	109	1365	148	1434	154	1582	207	1638	227	1689	252	1737	279	1829	308	1964
800	981	75	1064	92	1144	109	1221	124	1294	139	1365	148	1434	154	1582	207	1638	227	1689	252	1737	279	1829	308	1964	335	2077
1000	1166	105	1241	124	1315	141	1387	159	1454	176	1520	191	1582	207	1638	227	1689	252	1737	279	1829	308	1964	335	2077	362	2200
1200	1374	142	1440	162	1506	182	1569	203	1630	224	1687	246	1739	271	1787	299	1832	330	1876	361	1920	391	1964	419	2007	444	2140
1400	1591	183	1647	209	1701	235	1755	263	1806	291	1854	320	1899	351	1942	382	1984	412	2026	442	2068	469	2110	496	2153	520	2286
1600	1778	258	1827	290	1876	323	1923	355	1970	386	2015	416	2059	444	2102	470	2144	494	2185	519	2227	545	2268	572	2309	600	2442
1800	1973	352	2018	383	2063	415	2107	445	2151	476	2194	504	2237	531	2279	557	2319	584	2359	613	2397	645	2435	679	2471	713	2604
2000	2182	437	2224	468	2265	499	2306	531	2346	563	2385	596	2424	630	2461	666	2496	705	2530	745	2564	786	2598	826	2631	866	2764
2200	2388	540	2426	576	2464	613	2500	651	2536	691	2571	731	2605	774	2637	819	2668	863	2700	907	2732	949	2764	990	2795	1029	2928
2400	2589	679	2624	719	2658	761	2691	803	2724	846	2756	890	2786	935	2816	980	2846	1025	2876	1068	2907	1109	2937	1149	2967	1188	3100
2600	2787	845	2819	887	2850	930	2881	973	2911	1017	2941	1060	2970	1104	2999	1147	3028	1189	3057	1230	3087	1270	3117	1309	3147	1386	3280
2800	2983	1021	3013	1063	3042	1106	3070	1149	3099	1191	3128	1231	3157	1191	3187	1234	3216	1277	3245	1320	3274	1363	3303	1406	3332	1449	3465

Total Static Pressure - in. w.g.

Total Air cfm	Total Static Pressure - in. w.g.																											
	1.4		1.5		1.6		1.7		1.8		1.9		2.0															
	RPM	Watts	RPM	Watts	RPM	Watts	RPM	Watts	RPM	Watts	RPM	Watts	RPM	Watts														
800	---	---	---	---	---	---	---	---	---	---	---	---	---	---														
1000	1916	386	1957	408	1998	428	2037	447	2077	465	2116	484	2155	503	2194	522	2233	541	2272	560	2311	579	2350	598	2389	617	2428	
1200	2049	468	2089	490	2128	510	2168	529	2207	549	2246	569	2285	591	2324	611	2363	631	2402	651	2441	671	2480	691	2519	711	2558	
1400	2194	543	2235	565	2274	588	2313	611	2350	637	2387	664	2423	694	2462	722	2500	751	2538	780	2576	809	2614	838	2652	867	2690	
1600	2349	627	2387	657	2423	688	2457	722	2490	757	2522	793	2554	830	2586	864	2618	903	2650	942	2682	981	2714	1020	2746	1059	2778	
1800	2506	749	2539	787	2571	825	2602	864	2632	903	2662	942	2692	981	2722	1024	2752	1063	2782	1101	2812	1140	2842	1179	2872	1218	2902	
2000	2663	906	2694	945	2725	985	2755	1024	2785	1063	2815	1101	2845	1138	2875	1221	2905	1259	2935	1297	2965	1335	2995	1373	3025	1411	3055	
2200	2826	1068	2857	1107	2887	1146	2916	1184	2946	1221	2975	1259	3005	1296	3035	1333	3065	1371	3095	1409	3125	1447	3155	1485	3185	1523	3215	
2400	2997	1227	3027	1266	3056	1304	3085	1342	3114	1381	3143	1419	3172	1457	3201	1495	3230	1533	3259	1571	3288	1609	3317	1647	3346	1685	3375	
2600	---	---	---	---	---	---	---	---	---	---	---	---	---	---	---	---	---	---	---	---	---	---	---	---	---	---	---	---
2800	---	---	---	---	---	---	---	---	---	---	---	---	---	---	---	---	---	---	---	---	---	---	---	---	---	---	---	---

BLOWER DATA

BLOWER TABLE INCLUDES RESISTANCE FOR BASE UNIT ONLY WITH DRY INDOOR COIL AND AIR FILTERS IN PLACE.

1.5 HP | 4 ROW (060 | 072)

FOR ALL UNITS ADD:

- 1 - Any factory installed options air resistance (heat section, economizer, etc.).
- 2 - Any field installed accessories air resistance (duct resistance, diffuser, etc.).

See Page 14 for wet coil and options/accessory air resistance data. See Page 14 for minimum air volume with electric heat.

DOWNFLOW

Total Air cfm	Total Static Pressure - in. w.g.																											
	0.1		0.2		0.3		0.4		0.5		0.6		0.7		0.8		0.9		1.0		1.1		1.2		1.3			
	RPM	Watts	RPM	Watts	RPM	Watts	RPM	Watts	RPM	Watts	RPM	Watts	RPM	Watts	RPM	Watts	RPM	Watts	RPM	Watts	RPM	Watts	RPM	Watts	RPM	Watts	RPM	Watts
400	720	20	805	41	880	60	---	---	---	---	---	---	---	---	---	---	---	---	---	---	---	---	---	---	---	---		
600	849	51	933	73	1011	93	1083	112	1152	128	1229	130	1367	170	1443	175	1514	183	1578	198	1634	222	1684	252	1734	281	1783	309
800	978	81	1064	103	1145	124	1220	144	1291	162	1367	170	1367	170	1443	175	1514	183	1578	198	1634	222	1684	252	1734	281	1783	309
1000	1147	116	1225	138	1302	159	1376	179	1446	198	1517	211	1517	211	1586	224	1648	242	1703	266	1753	296	1801	327	1849	356	1896	382
1200	1347	154	1418	175	1487	196	1555	216	1620	235	1684	253	1684	253	1743	275	1795	302	1841	336	1884	373	1930	405	1976	433	2021	458
1400	1571	182	1629	209	1686	236	1742	262	1798	288	1850	315	1850	315	1899	346	1943	380	1984	417	2025	453	2068	485	2113	512	2156	537
1600	1753	252	1803	286	1853	318	1902	351	1951	383	1998	415	1998	415	2043	447	2087	478	2130	508	2173	539	2216	568	2259	595	2302	621
1800	1935	339	1983	371	2030	403	2076	434	2122	465	2167	495	2167	495	2210	524	2253	554	2295	586	2337	618	2378	650	2418	682	2458	714
2000	2127	415	2172	448	2217	481	2260	513	2303	546	2345	579	2345	579	2385	614	2425	653	2464	693	2503	734	2541	774	2578	814	2614	855
2200	2321	507	2363	545	2404	583	2444	623	2484	664	2522	707	2522	707	2560	753	2596	801	2632	848	2667	895	2703	939	2737	981	2770	1023
2400	2516	635	2556	679	2594	723	2631	767	2668	813	2703	861	2703	861	2737	909	2772	958	2805	1005	2839	1050	2872	1093	2905	1135	2936	1176
2600	2715	796	2751	841	2786	887	2820	933	2854	980	2887	1027	2887	1027	2919	1074	2952	1120	2983	1164	3015	1207	3046	1249	3077	1290	3107	1330
2800	2915	970	2947	1016	2979	1062	3011	1107	3042	1152	3073	1197	3073	1197	3104	1240	3134	1282	3164	1323	3193	1364	3222	1404	3251	1445	3280	1485
3000	3112	1142	3142	1187	3172	1232	3202	1276	3232	1319	3261	1361	3261	1361	3289	1401	3317	1441	3344	1480	3371	1520	3399	1560	1600	1600	3453	1638

Total Static Pressure - in. w.g.

Total Air cfm	Total Static Pressure - in. w.g.													
	1.4		1.5		1.6		1.7		1.8		1.9		2.0	
	RPM	Watts	RPM	Watts	RPM	Watts	RPM	Watts	RPM	Watts	RPM	Watts	RPM	Watts
800	1830	335	---	---	---	---	---	---	---	---	---	---	---	
1000	1940	405	1983	426	2026	446	2068	466	2111	488	2154	512	2196	536
1200	2064	480	2106	501	2148	522	2190	544	2232	569	2273	595	2314	623
1400	2199	560	2241	584	2282	608	2323	634	2363	664	2402	694	2440	726
1600	2344	647	2384	675	2424	706	2462	740	2498	776	2535	811	2571	848
1800	2497	749	2533	788	2568	829	2602	872	2636	914	2671	953	2705	992
2000	2648	898	2681	941	2714	986	2746	1030	2779	1072	2812	1112	2845	1152
2200	2803	1064	2835	1105	2867	1145	2899	1186	2931	1225	2964	1265	2995	1303
2400	2968	1217	2999	1258	3031	1298	3062	1337	3093	1377	3124	1415	3156	1454
2600	3138	1371	3168	1411	3199	1450	3229	1489	3260	1528	3290	1566	3321	1604
2800	3309	1524	3338	1563	3368	1602	3398	1640	3428	1678	3458	1717	3488	1755
3000	3481	1677	3508	1715	3537	1752	3566	1790	3595	1828	3625	1866	3655	1904

BLOWER DATA

FACTORY INSTALLED OPTIONS/FIELD INSTALLED ACCESSORY AIR RESISTANCE - in. w.g.

Air Volume cfm	Wet Indoor Coil		Electric Heat	Economizer	Filters		
	036, 048	060, 072			MERV 8	MERV 13	MERV 16
800	0.01	---	0.01	0.04	0.04	0.05	0.04
1000	0.02	0.02	0.03	0.04	0.04	0.07	0.05
1200	0.03	0.04	0.06	0.04	0.04	0.07	0.05
1400	0.04	0.05	0.09	0.04	0.04	0.07	0.06
1600	0.05	0.07	0.12	0.04	0.04	0.07	0.08
1800	0.06	0.08	0.15	0.05	0.04	0.07	0.09
2000	0.08	0.10	0.18	0.05	0.05	0.08	0.10
2200	---	0.11	0.18	0.05	0.05	0.08	0.11
2400	---	0.13	0.20	0.05	0.05	0.08	0.12

MINIMUM AIR VOLUME REQUIRED FOR ELECTRIC HEAT

Size	kW Size	Minimum CFM	
		Direct Drive ECM	DirectPlus™ Direct Drive ECM
036-072	7.5	600	1200
	15	1100	1350
	22.5	1600	1800
072	30	N/A	2000

POWER EXHAUST FAN PERFORMANCE

Return Air System Static Pressure in. w.g.	Air Volume Exhausted cfm
0.00	2000
0.05	1990
0.10	1924
0.15	1810
0.20	1664
0.25	1507
0.30	1350
0.35	1210

CEILING DIFFUSERS AIR RESISTANCE (in. w.g.)

Air Volume - cfm	RTD11-95S Step-Down Diffuser			FD11-95S Flush Diffuser
	2 Ends Open	1 Side & 2 Ends Open	All Ends & Sides Open	
1800	0.13	0.11	0.09	0.09
2000	0.15	0.13	0.11	0.10
2200	0.18	0.15	0.12	0.12
2400	0.21	0.18	0.15	0.14
2600	0.24	0.21	0.18	0.17
2800	0.27	0.24	0.21	0.20
3000	0.32	0.29	0.25	0.25

ELECTRICAL/ELECTRIC HEAT DATA
3 TON

Model		LHT036H5							
¹ Voltage - 60Hz		208/230V - 1 Ph		208/230V - 3 Ph		460V - 3 Ph		575V - 3 Ph	
Compressor (Non-Inverter)	Rated Load Amps	14.6		9.9		4.8		3.5	
	Locked Rotor Amps	90		82		44.3		28.7	
Outdoor Fan Motor	Full Load Amps (1 ECM)	2.8		2.8		1.4		1.1	
Power Exhaust (1) 0.33 HP	Full Load Amps	2.4		2.4		1.3		1	
Service Outlet 115V GFI (amps)		15		15		15		20	
Indoor Blower Motor	HP	0.5	0.5	1.5	0.5	1.5	0.5	1.5	
	Full Load Amps	4.3	4.3	4.4	2.2	2.3	1.7	2.3	
² Maximum Overcurrent Protection (MOCP)	Unit Only	35	25	25	15	15	15	15	
	With (1) 0.33 HP Power Exhaust	40	30	30	15	15	15	15	
³ Minimum Circuit Ampacity MCA)	Unit Only	26	20	20	10	10	8	8	
	With (1) 0.33 HP Power Exhaust	28	22	22	11	12	9	9	

ELECTRIC HEAT DATA

Electric Heat Voltage			208V	240V	208V	240V	208V	240V	480V	600V		
² Maximum Overcurrent Protection (MOCP)	Unit+ Electric Heat	7.5 kW	⁴ 60	70	45	45	45	45	25	25	20	20
		15 kW	⁴ 100	110	⁴ 60	70	⁴ 60	70	35	35	30	30
³ Minimum Circuit Ampacity MCA)	Unit+ Electric Heat	7.5 kW	60	65	40	43	40	43	21	21	17	17
		15 kW	94	104	59	65	59	65	33	33	26	26
² Maximum Overcurrent Protection (MOCP)	Unit+ Electric Heat and (1) 0.33 HP Power Exhaust	7.5 kW	70	70	45	45	45	45	25	25	20	20
		15 kW	⁴ 100	110	70	70	70	70	35	35	30	30
³ Minimum Circuit Ampacity MCA)	Unit+ Electric Heat and (1) 0.33 HP Power Exhaust	7.5 kW	62	67	42	45	42	45	23	23	18	18
		15 kW	96	106	61	67	62	68	34	34	27	27

ELECTRICAL ACCESSORIES

Disconnects	7.5 kW	22A23	22A23	22A23	22A23	22A23	22A23	22A23	22A23	22A23	22A23
	15 kW	22A24	22A24	22A23	22A23	22A23	22A23	22A23	22A23	22A23	22A23

Disconnects - 22A23 - 80A
22A24 - 150A

NOTE - All units have a minimum Short Circuit Current Rating (SCCR) of 5000 amps.

¹ Extremes of operating range are plus and minus 10% of line voltage.

² HACR type breaker or fuse.

³ Refer to National or Canadian Electrical Code manual to determine wire, fuse and disconnect size requirements.

⁴ Factory installed circuit breaker not available.

ELECTRICAL/ELECTRIC HEAT DATA
4 TON

Model		LHT048H5									
¹ Voltage - 60Hz		208/230V - 1 Ph		208/230V - 3 Ph		460V - 3 Ph		575V - 3 Ph			
Compressor	Rated Load Amps	18.3		11.9		6.8		4.8			
	Locked Rotor Amps	138		112		61.8		39			
Outdoor Fan Motor	Full Load Amps (1 ECM)	2.8		2.8		1.4		1.1			
Power Exhaust (1) 0.33 HP	Full Load Amps	2.4		2.4		1.3		1			
Service Outlet 115V GFI (amps)		15		15		15		20			
Indoor Blower Motor	HP	1		1		1.5		1		1.5	
	Full Load Amps	7.4		7.4		4.4		3.7		2.3	
² Maximum Overcurrent Protection (MOCP)	Unit Only	50		35		30		20		15	
	With (1) 0.33 HP Power Exhaust	50		35		35		20		20	
³ Minimum Circuit Ampacity (MCA)	Unit Only	34		26		23		14		13	
	With (1) 0.33 HP Power Exhaust	36		28		25		15		14	

ELECTRIC HEAT DATA

Electric Heat Voltage			208V	240V	208V	240V	208V	240V	480V	600V		
² Maximum Overcurrent Protection (MOCP)	Unit+ Electric Heat	7.5 kW	⁴ 70	80	50	50	⁴ 45	50	25	25	20	20
		15 kW	⁴ 110	125	⁴ 70	80	70	70	40	35	30	30
³ Minimum Circuit Ampacity (MCA)	Unit+ Electric Heat	7.5 kW	67	73	45	48	42	45	25	24	20	19
		15 kW	101	112	65	71	62	68	37	35	29	28
² Maximum Overcurrent Protection (MOCP)	Unit+ Electric Heat and (1) 0.33 HP Power Exhaust	7.5 kW	80	80	⁴ 50	60	50	50	30	25	25	20
		15 kW	⁴ 110	125	⁴ 70	80	70	70	40	40	30	30
³ Minimum Circuit Ampacity (MCA)	Unit+ Electric Heat and (1) 0.33 HP Power Exhaust	7.5 kW	70	75	48	51	45	48	27	25	21	20
		15 kW	104	114	67	73	64	70	38	37	30	29

ELECTRIC HEAT DATA

Disconnects	7.5 kW	22A23	22A23	22A23	22A23	22A23	22A23	22A23	22A23	22A23	22A23
	15 kW	22A24	22A24	22A23	22A23	22A23	22A23	22A23	22A23	22A23	22A23

Disconnects - 22A23 - 80A
22A24 - 150A

NOTE - All units have a minimum Short Circuit Current Rating (SCCR) of 5000 amps.

¹ Extremes of operating range are plus and minus 10% of line voltage.

² HACR type breaker or fuse.

³ Refer to National or Canadian Electrical Code manual to determine wire, fuse and disconnect size requirements.

⁴ Factory installed circuit breaker not available.

ELECTRICAL/ELECTRIC HEAT DATA
5 TON

Model		LHT060H5							
¹ Voltage - 60Hz		208/230V - 1 Ph	208/230V - 3 Ph			460V - 3 Ph		575V - 3 Ph	
Compressor	Rated Load Amps	25.2	13.8			6.9		5.8	
	Locked Rotor Amps	147.3	150			58		47.8	
Outdoor Fan Motor	Full Load Amps (1 ECM)	2.8	2.8			1.4		1.1	
Power Exhaust (1) 0.33 HP	Full Load Amps	2.4	2.4			1.3		1	
Service Outlet 115V GFI (amps)		15	15			15		20	
Indoor Blower Motor	HP	1	1	1.5	1	1.5	1	1.5	
	Full Load Amps	7.4	7.4	4.4	3.7	2.3	3	2.3	
² Maximum Overcurrent Protection (MOCP)	Unit Only	60	40	35	20	15	15	15	
	With (1) 0.33 HP Power Exhaust	60	40	40	20	20	15	15	
³ Minimum Circuit Ampacity MCA)	Unit Only	42	28	25	14	13	12	11	
	With (1) 0.33 HP Power Exhaust	45	30	27	16	14	13	12	

ELECTRIC HEAT DATA

Electric Heat Voltage			208V	240V	208V	240V	208V	240V	480V		600V	
² Maximum Overcurrent Protection (MOCP)	Unit+ Electric Heat	7.5 kW	90	90	⁴ 50	60	50	50	30	25	25	20
		15 kW	⁴ 110	125	⁴ 70	80	70	70	40	35	30	30
		22.5 kW	⁴ 150	175	⁴ 90	100	⁴ 90	100	50	50	40	40
³ Minimum Circuit Ampacity MCA)	Unit+ Electric Heat	7.5 kW	76	81	47	51	44	48	26	24	21	20
		15 kW	110	120	67	73	64	70	37	35	30	29
		22.5 kW	144	159	87	96	84	93	48	47	39	38
² Maximum Overcurrent Protection (MOCP)	Unit+ Electric Heat and (1) 0.33 HP Power Exhaust	7.5 kW	⁴ 90	100	⁴ 50	60	50	50	30	25	25	25
		15 kW	125	125	⁴ 70	80	⁴ 70	80	40	40	35	30
		22.5 kW	⁴ 150	175	⁴ 90	100	⁴ 90	100	50	50	40	40
³ Minimum Circuit Ampacity MCA)	Unit+ Electric Heat and (1) 0.33 HP Power Exhaust	7.5 kW	78	84	50	53	47	50	27	25	22	21
		15 kW	112	123	69	75	66	72	38	37	31	30
		22.5 kW	146	162	89	98	86	95	49	48	40	39

ELECTRICAL ACCESSORIES

Disconnects	7.5 kW	22A24	22A24	22A23	22A23	22A23	22A23	22A23	22A23	22A23	22A23	22A23
	15 kW	22A24	22A24	22A23	22A23	22A23	22A23	22A23	22A23	22A23	22A23	22A23
	22.5 kW	22A24	N/A	22A24	22A24	22A24	22A24	22A23	22A23	22A23	22A23	22A23

Disconnects - 22A23 - 80A
22A24 - 150A

NOTE - All units have a minimum Short Circuit Current Rating (SCCR) of 5000 amps.

¹ Extremes of operating range are plus and minus 10% of line voltage.

² HACR type breaker or fuse.

³ Refer to National or Canadian Electrical Code manual to determine wire, fuse and disconnect size requirements.

⁴ Factory installed circuit breaker not available.

ELECTRICAL/ELECTRIC HEAT DATA
6 TON

Model		LHT072H5E		
¹ Voltage - 60Hz		208/230V - 3 Ph	460V - 3 Ph	575 - 3Ph
Compressor (Non-Inverter)	Rated Load Amps	19.2	9.1	6.2
	Locked Rotor Amps	162.3	70.8	58.2
Outdoor Fan Motor	Full Load Amps (1 ECM)	2.8	1.4	1.1
Power Exhaust (1) 0.33 HP	Full Load Amps	2.4	1.3	1
Service Outlet 115V GFI (amps)		15	15	20
Indoor Blower Motor	HP	1.5	1.5	1.5
	Full Load Amps	4.4	2.3	2.3
² Maximum Overcurrent Protection (MOCP)	Unit Only	50	20	15
	With (1) 0.33 HP Power Exhaust	50	25	15
³ Minimum Circuit Ampacity (MCA)	Unit Only	32	16	12
	With (1) 0.33 HP Power Exhaust	34	17	13

ELECTRIC HEAT DATA

Electric Heat Voltage			208V	240V	480V	600V
² Maximum Overcurrent Protection (MOCP)	Unit+ Electric Heat	7.5 kW	60	60	30	25
		15 kW	80	80	40	30
		22.5 kW	⁴ 90	100	50	40
³ Minimum Circuit Ampacity (MCA)	Unit+ Electric Heat	7.5 kW	51	54	27	21
		15 kW	71	77	38	30
		22.5 kW	90	99	49	39
² Maximum Overcurrent Protection (MOCP)	Unit+ Electric Heat and (1) 0.33 HP Power Exhaust	7.5 kW	4 60	70	30	25
		15 kW	80	80	40	35
		22.5 kW	⁴ 100	110	60	40
		30 kW	54	57	28	22
³ Minimum Circuit Ampacity (MCA)	Unit+ Electric Heat and (1) 0.33 HP Power Exhaust	7.5 kW	73	79	39	31
		15 kW	93	102	51	40
		22.5 kW				

ELECTRICAL ACCESSORIES

Disconnects	7.5 kW	22A23	22A23	22A23	22A23
	15 kW	22A23	22A23	22A23	22A23
	22.5 kW	22A24	22A24	22A23	22A23

Disconnects - 22A23 - 80A
22A24 - 150A

NOTE - All units have a minimum Short Circuit Current Rating (SCCR) of 5kA.

¹ Extremes of operating range are plus and minus 10% of line voltage.

² HACR type breaker or fuse.

³ Refer to National or Canadian Electrical Code manual to determine wire, fuse and disconnect size requirements.

⁴ Factory installed circuit breaker not available.

ELECTRIC HEAT CAPACITIES

Volts Input	7.5 kW			15 kW			22.5 kW		
	kW Input	Btuh Output	Stages	kW Input	Btuh Output	Stages	kW Input	Btuh Output	Stages
208	5.6	19,100	1	11.3	38,600	1	16.9	57,700	2
220	6.3	21,500	1	12.6	43,000	1	18.9	64,500	2
230	6.9	23,600	1	13.8	47,100	1	20.7	70,700	2
240	7.5	25,600	1	15.0	51,200	1	22.5	76,800	2
440	6.9	21,500	1	12.6	43,000	1	18.9	64,500	2
460	6.9	23,600	1	13.8	47,100	1	20.7	70,700	2
480	7.5	25,600	1	15.0	51,200	1	22.5	76,800	2
550	6.3	21,500	1	12.6	43,000	1	18.9	64,500	2
575	6.9	23,600	1	13.8	47,100	1	20.7	70,700	2
600	7.5	25,600	1	15.0	51,200	1	22.5	76,800	2

MINIMUM R454B SPACE AND CFM REQUIREMENTS

Minimum Airflow ¹		
Unit	Q _{min} (CFM)	Q _{min} (m ³ h)
LHT036	360	610
LHT048	369	626
LHT060	427	725
LHT072	361	612

¹ The minimum airflow is the lowest CFM allowed during venting operation (leak mitigation)

Minimum Room Area of Conditioned Space ²		
Unit	TA _{min} (ft ²)	TA _{min} (m ²)
LHT036	198.68	18.46
LHT048	204.17	18.97
LHT060	236.21	21.94
LHT072	199.59	18.54

² The minimum room area of conditioned space is the smallest area the unit can service

Refrigerant Charge R-454B		
Unit	M _c (lbs)	M _c (kg)
LHT036	13.56	6.15
LHT048	13.94	6.32
LHT060	16.13	7.31
LHT072	13.63	6.18

Altitude Adjustment Factor ³									
Halt	0	200	400	600	800	1000	1200	1400	1600
AF	1	1	1	1	1.02	1.05	1.04	1.1	1.12
Halt	1600	1800	2000	2200	2400	2600	2800	3000	3200
AF	1.12	1.15	1.18	1.21	1.25	1.28	1.32	1.36	1.4

³ Use the Altitude Adjustment Factor to adjust the values in the tables above to different altitudes. Find the relevant altitude above sea level in the two "Halt" rows and then multiply the value needed from the tables above by the altitude factor number. Example: For the minimum airflow in CFM for an LDT/LHT036 at 1000 ft. above sea level, multiply 360 by 1.05 to get 378 CFM as the new Qmin .

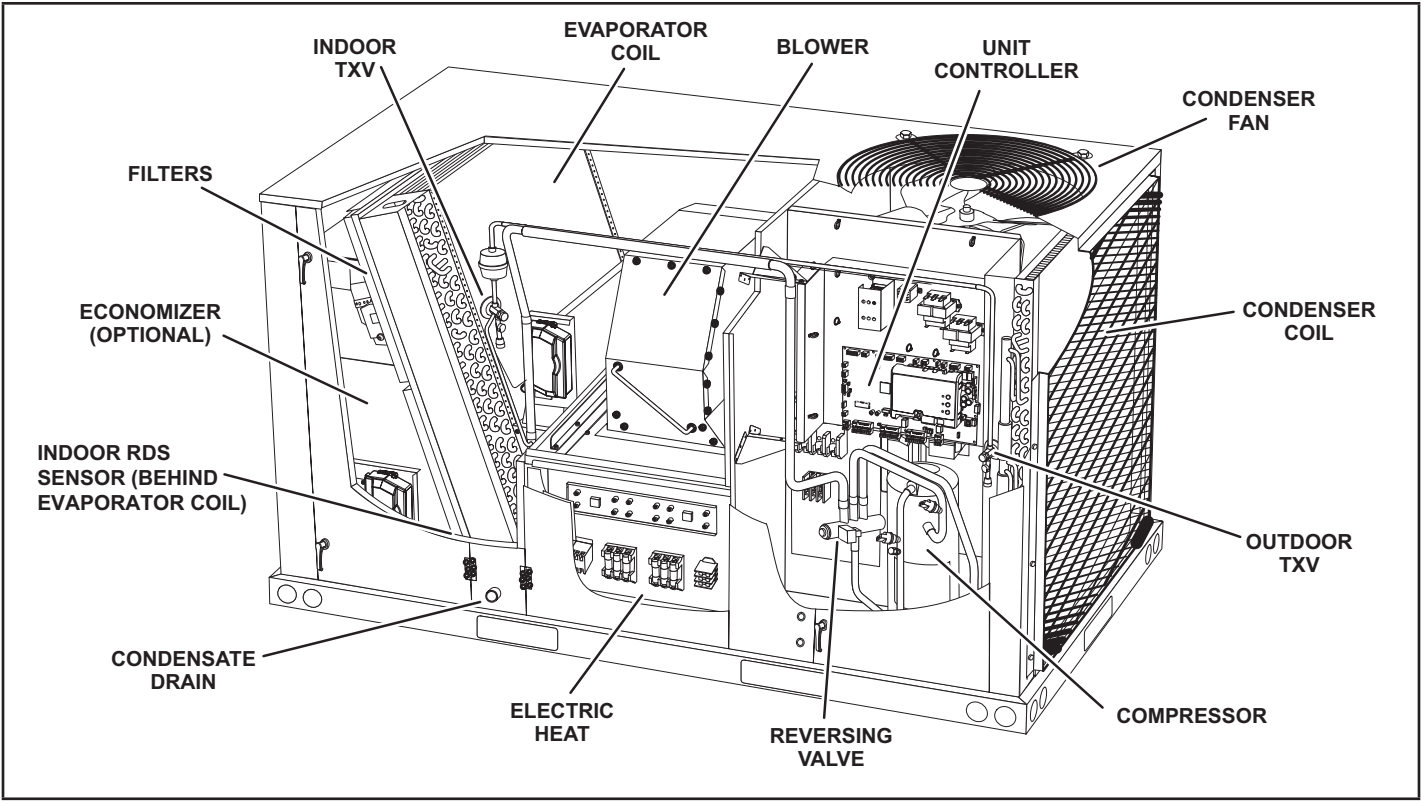

FIGURE 1

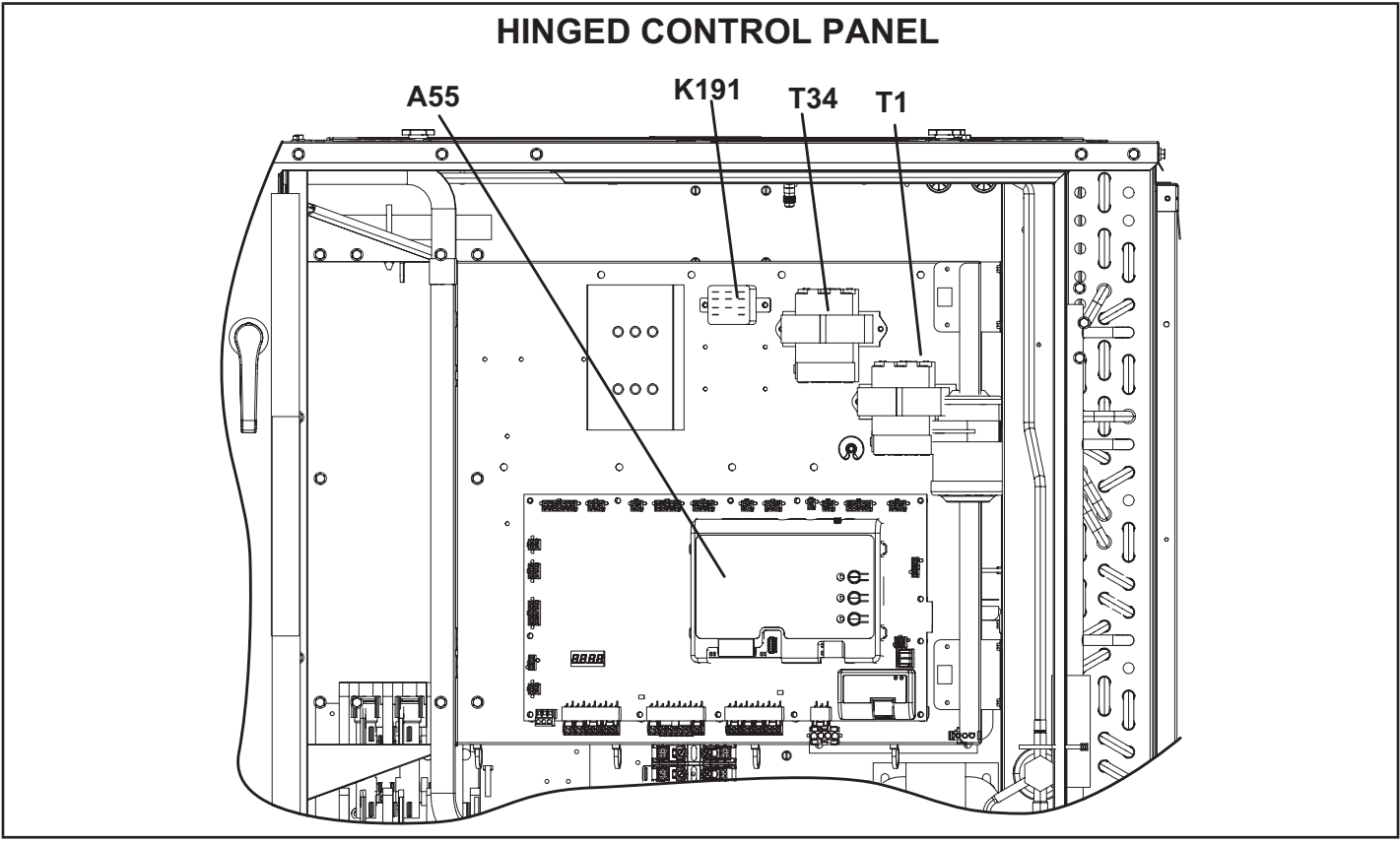

FIGURE 2

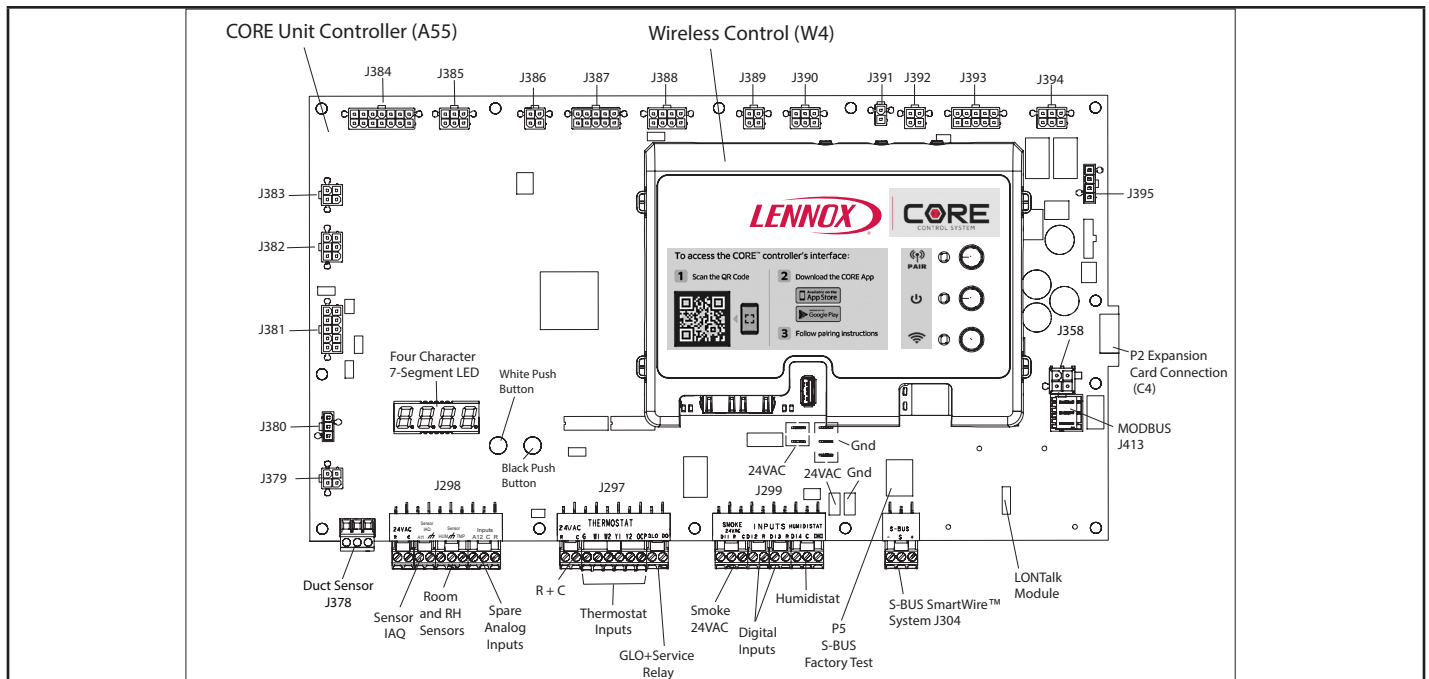

FIGURE 3

I-UNIT COMPONENTS

ELECTROSTATIC DISCHARGE (ESD) Precautions and Procedures

CAUTION

Electrostatic discharge can affect electronic components. Take precautions to neutralize electrostatic charge by touching your hand and tools to metal prior to handling the control.

All 3 through 6 ton (7 through 15.5 kW) units are configured to order units (CTO). The LHT unit components are shown in FIGURE 1. All units come standard with hinged unit panels. All L1, L2, and L3 wiring is color coded; L1 is red, L2 is yellow, and L3 is blue.

A-Control Box Components

LHT control box components are shown in FIGURE 2. The control box is located in the upper right portion of the compressor compartment.

1-Control Transformers T1/T43

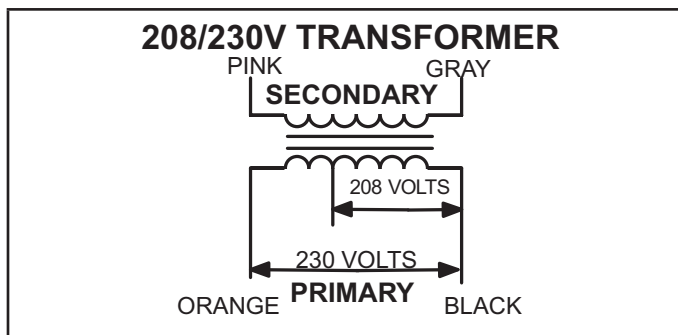

FIGURE 4

All use a single line voltage to 24VAC transformer mounted on the hinged control panel. Transformer supplies power to control circuits in the unit. The transformer is rated at 70VA and is protected by a 3.5 amp circuit (CB8). The 208/230 voltage transformers use two primary voltage taps as shown in FIGURE 4, while the 460 (G) voltage transformer use a single primary voltage tap. T43 is used for units with hot gas reheat for additional 24VAC.

2-Transformer T4 (J voltage)

All J volt units are equipped with a line voltage to 460V 3-phase transformer to power the indoor blower motor. T4 is mounted in the back panel of the compressor section above T5.

3-Transformer T5 (G and J voltage)

All units use transformer T5 mounted in the back panel in the compressor section. T5 is a line voltage to 230V transformer to power the combustion air inducer, outdoor fan motor, and optional UVC light ballast. It is connected to line voltage and is powered at all times.

4-Unit Controller A55 (FIGURE 3)

The Unit Controller provides all unit control functions, unit status information, unit diagnostics, programmable parameters, and USB verification and profile sharing. The unit controller can only be interfaced with via the CORE Service mobile app. Refer to the Unit controller instructions provided for additional details on pairing and app functions.

Attention!

Use this QR code to download the mobile service app. Follow the prompts to pair the app with the unit control system and configure the unit. Refer to the “Download Mobile App” section in this manual and the Setup Guide provided with this unit. The QR code is also available in the unit control area.



The app can be downloaded from the appropriate iOS or Android store. Look for the following



The Unit Controller uses input from a zone/room sensor cooling, a thermostat, or a third-party controller to operate the unit. Zone/room sensor, thermostat, and third-party controller wires are connected to J297 on the Unit Controller.

Many default Unit Controller settings are adjustable. Refer to the unit installation instruction or the Unit Controller manual provided with the unit.

The Unit Controller is configured to identify optional kits and accessories for proper function. Each character in the configuration ID represents a different option. Refer to the unit installation instruction or the Unit Controller manual provided with the unit.

5-Compressor Contactor K1

The Unit Controller closes n.o. K1 contacts to provide power to the inverter control board (A192). The contactor does not energize the compressor in the same manner as a traditional cooling system. Three phase units use three pole double break contactors with a 24 volt coil.

6-Crankcase Heater Relay K191

All units use relay K191 to control crnkcase heater HR1.

7-Power Exhaust Relay K65 (PED units)

Power exhaust relay K65 is a N.O. DPDT relay with a 24VAC coil. K65 is used in all LHT units equipped with the optional power exhaust dampers. K65 is energized by the economizer control panel (A56), after the economizer dampers reach 50% open (adjustable in ECTO). When K65 closes, the exhaust fan B10 is energized.

B-Cooling Components

All units use a single cooling circuit consisting of a two-speed compressor, all aluminum condenser coil and evaporator coil. See FIGURE 5. All units use one draw-through type condenser fan and a single direct drive blower. The blower draws air across the evaporator during unit operation.

Cooling may be supplemented by a factory- or field-installed economizer. The evaporator coil is slab type and uses a thermostatic expansion valve as the primary refrigerant metering device. The compressor is protected by a high pressure switch (S4) on the discharge line, a high temperature limit switch (S5) on the compressor, and a low pressure switch (S87) on the suction line. See FIGURE 5.

1-High Pressure Switch S4

The high pressure switch is an auto-reset SPST N.C. switch which opens on a pressure rise.

S4 is located in the compressor discharge line and wired to the A55 Unit Controller. When discharge pressure rises to 640 ± 10 psig (4412 ± 69 kPa) (indicating a problem in the system) the switch opens and the compressor inverter is de-energized (the economizer can continue to operate). The switch automatically resets at $475 + 10$ psig.

2-Low Pressure Switch S87

The compressor circuit is protected by a loss of charge switch located on the suction line. Switch opens at 40 psig ± 5 psig (276 ± 34 kPa) and automatically resets at 90 psig ± 5 psig (621 kPa \pm kPa).

3-High Temperature Limit Switch S5

The variable speed compressor is equipped with a compressor-mounted normally closed temperature switch that prevents compressor damage due to overheating caused by internal friction. The switch is located on top of the compressor casing. This switch senses the compressor casing temperature and opens at 239 - 257°F to shut-off compressor operation. The auto-reset switch closes when the compressor casing temperature falls to 151 - 187°F , and the compressor is re-energized. This switch is a single-pole, single-throw (SPST) bi-metallic switch and is wired to the A55 Unit Controller.

4- Reversing Valve

A refrigerant reversing valve with a 24 volt solenoid coil is used to reverse refrigerant flow during unit operation in all LHT units. The reversing valve is connected in the vapor line of the refrigerant circuit. The reversing valve coil is energized during cooling demand and during defrost. Reversing valve L1 is controlled by the A55 Control board in response to cooling demand or by defrost.

PLUMBING AND COMPRESSOR PROTECTION COMPONENTS

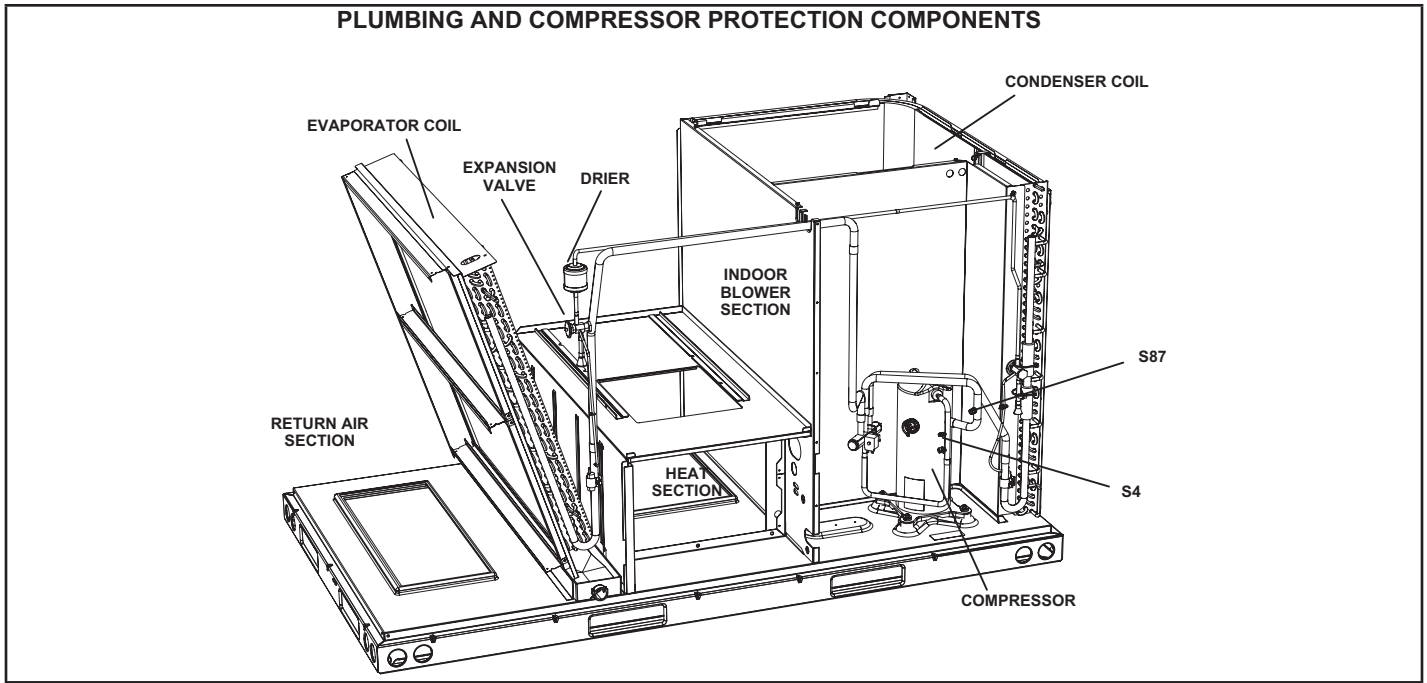

FIGURE 5

5-Thermistors

Units are equipped with two factory-installed thermistors (RT46 and RT48) located on different points on the refrigerant circuit.

The thermistors provide the Unit Controller with constant temperature readings of two specific locations on the refrigeration circuit. These temperatures are used as feedback in certain modes of unit operation. In addition, the Unit Controller uses these temperatures to initiate alarms such as loss of condenser or evaporator airflow and loss of charge.

The LHT036 - 072 units use the RT46 sensor on the indoor evaporator coil and the RT48 sensor on the outdoor condenser coil. See Figure 7, 8 and 9

TABLE 1		
Unit	Sensor Yellow	Figure
036, 048, 060, 072 Indoor Coil	RT46	6
036, 048 Outdoor Coil	RT48	7
060, 072 Outdoor Coil	RT48	8

6-Low Ambient Operation

When Outdoor Air Temperature (OAT) drops below 62°F (16.6°C) while in cooling operation, the Unit will modulate OD fan in order to maintain coil temperature observed on RT48. Once OAT exceeds 65°F (18.3°C), unit will resume normal operation. The intermittent fan operation results in higher evaporating temperature allowing the system to operate without icing the evaporator coil and losing capacity.

7-Defrost Control

The defrost control ensures that the heat pump outdoor coil does not ice excessively during the heating mode. The defrost control uses input from the coil and ambient sensor to uses demand defrost cycles from the M4 board. If system fails to do calibration or obtain readings for demand defrost, it will run timed defrost at customer setting. If electric heat is installed, it is energized during defrost cycle.

LHT/LDT036, 048, 060, 072
EVAPORATOR COIL
RT46

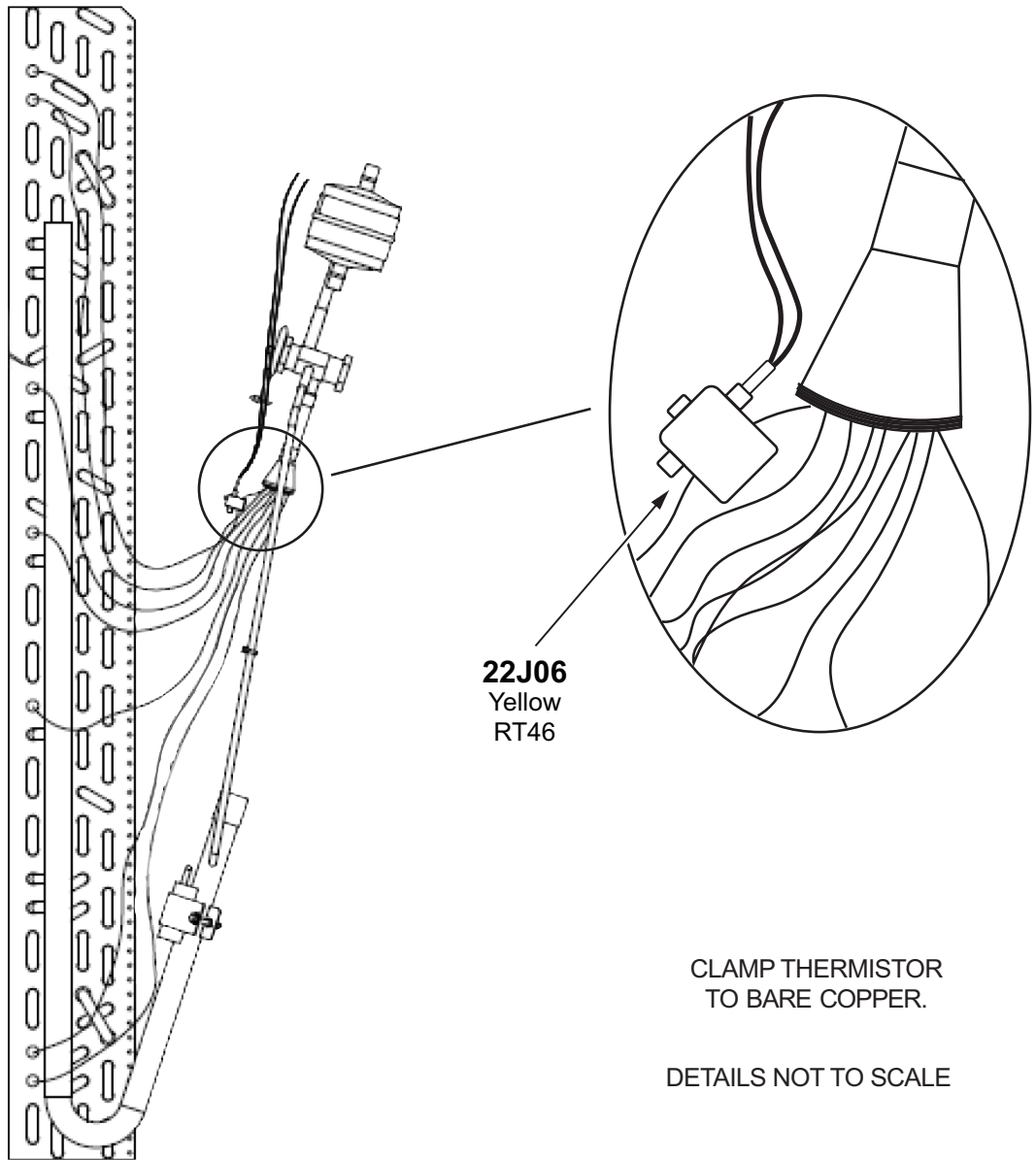

FIGURE 6

LHT/LDT036, 048
CONDENSER COIL
RT48

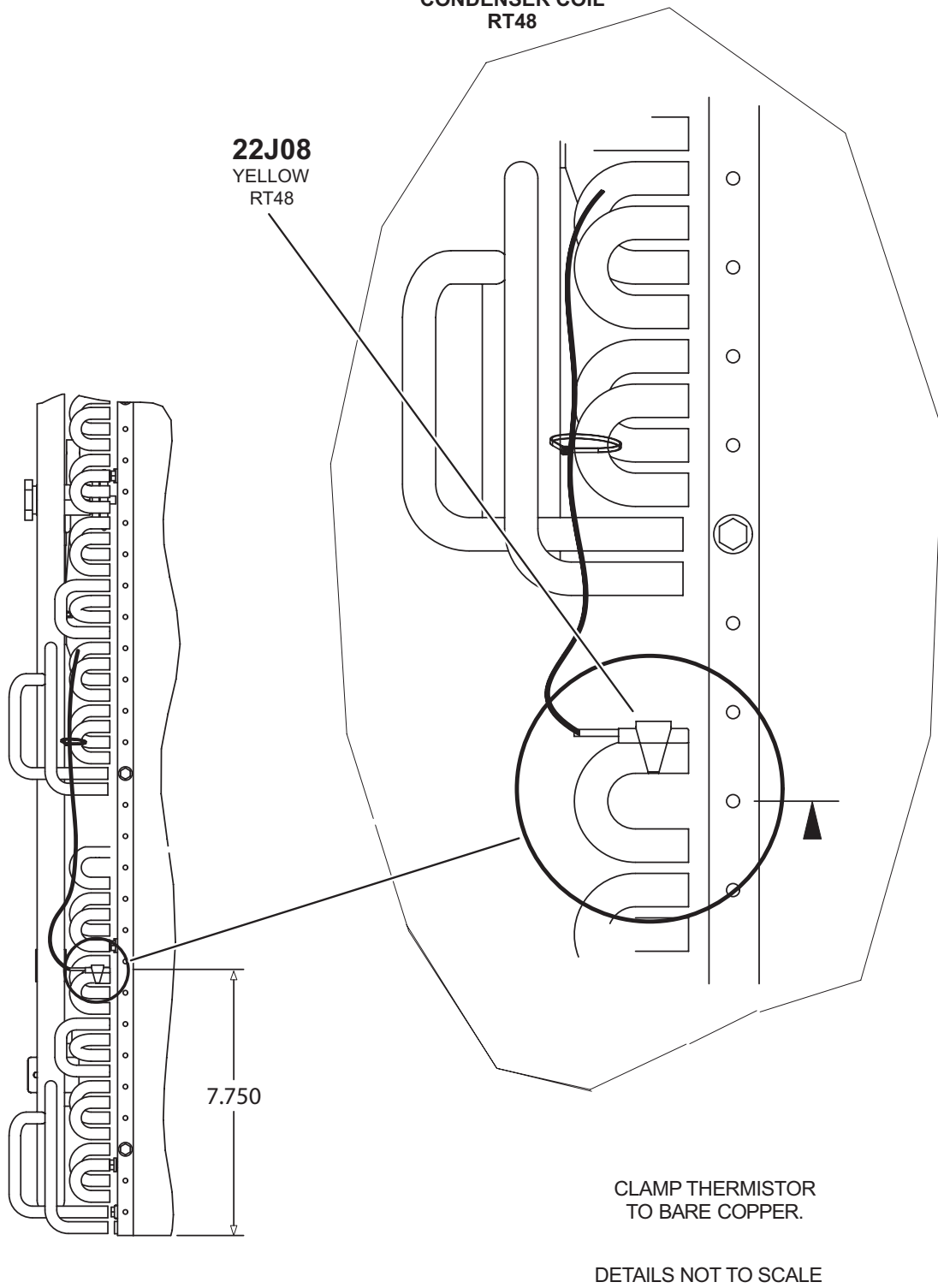
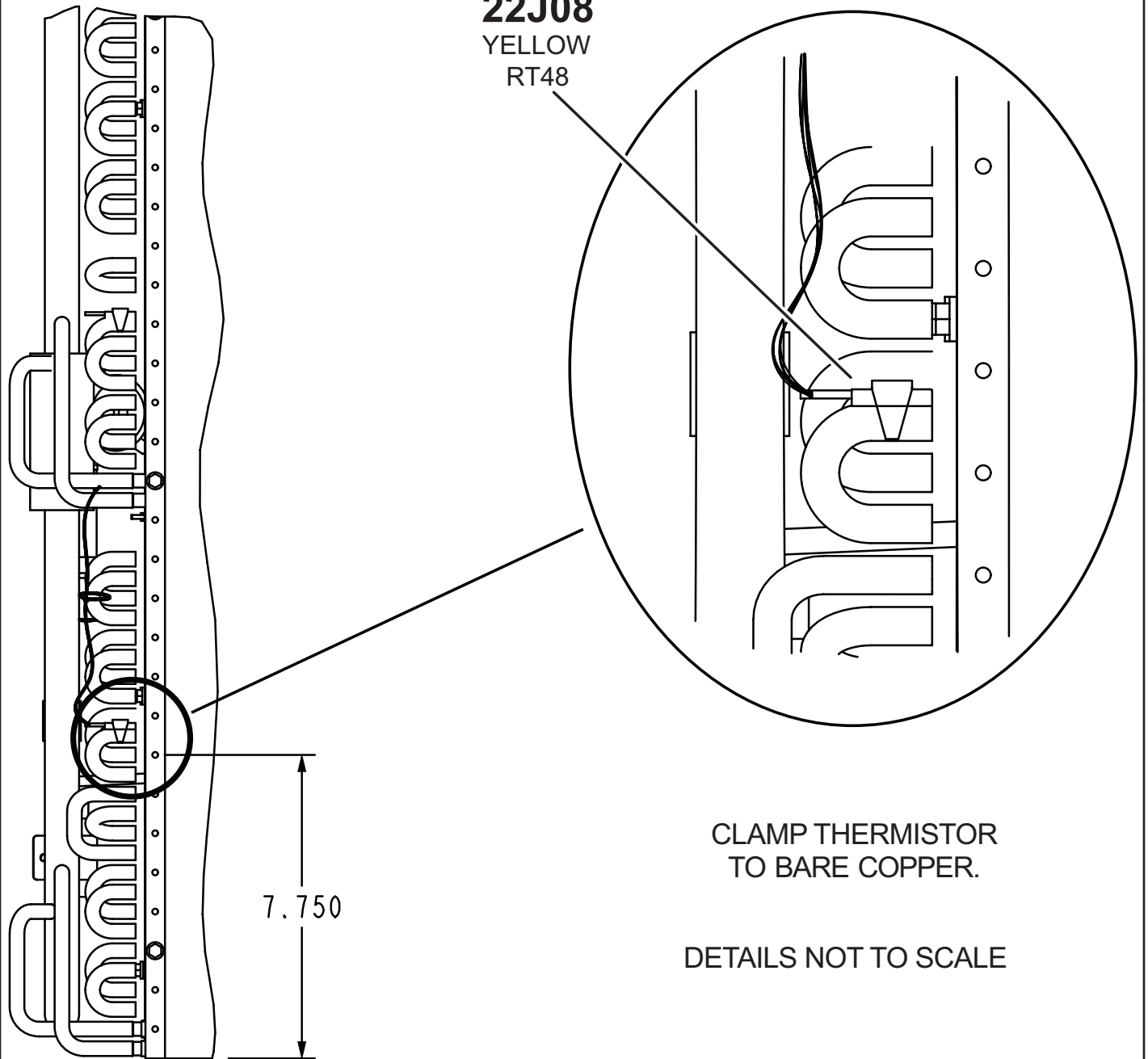

FIGURE 7

LHT/LDT060, 072
CONDENSER COIL
RT48

22J08
YELLOW
RT48



CLAMP THERMISTOR
TO BARE COPPER.

DETAILS NOT TO SCALE

FIGURE 8

8-RDS Sensors

Units are equipped with factory-installed RDS Sensors located on different points on the unit. The RDS sensors provide the Unit Controller with continuous readings for leaked refrigerant concentration levels and sensor health status (Good or Fault). These readings are used to modify unit operation to disperse the leaked refrigerant and to remove possible ignition sources. In addition, the Unit Controller uses these readings to initiate alarms to alert the operator of a refrigerant leak or faulty sensor(s).

Each sensor must be specifically placed for proper unit operation and to initiate valid alarms. To identify sensor locations see TABLE 2.

TABLE 2

RDS Sensor Figures			
Model	Qty.	Type	Figure
LHT036-072	1 sensor	ID SENSOR	FIGURE 9

The RDS Sensors and Controller shall only be replaced with parts specified by the appliance manufacturer.

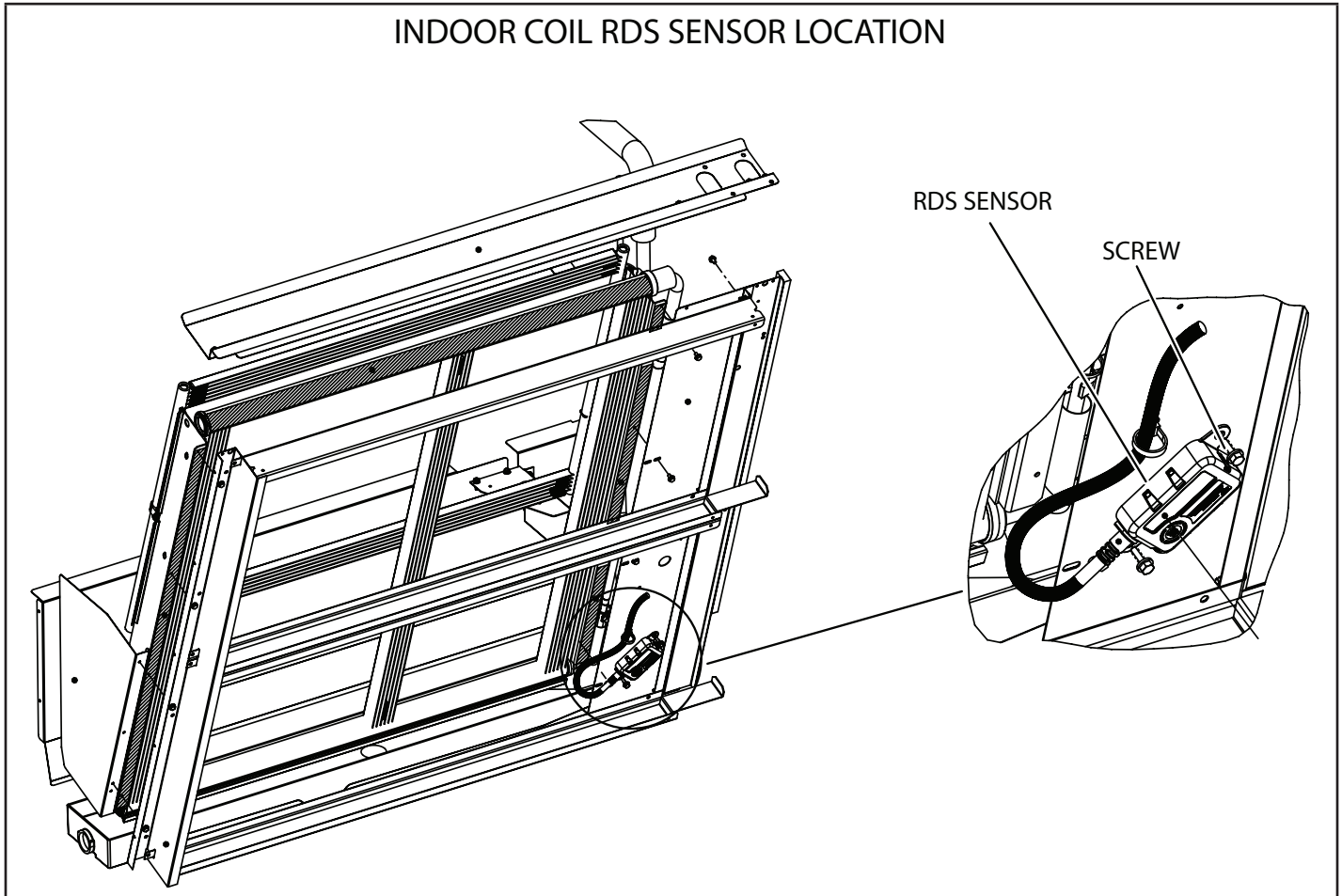

FIGURE 9

WARNING

Electrical shock hazard. Compressor must be grounded. Do not operate without protective cover over terminals. Disconnect power before removing protective cover. Discharge capacitors before servicing unit. Failure to follow these precautions could cause electrical shock resulting in injury or death.

9-Two-Speed Compressor B1

All units use one two-speed scroll compressor. See "SPECIFICATIONS" and "ELECTRICAL DATA" (table of contents) or compressor nameplate for compressor specifications.

10-Compressor Crankcase Heater (HR1)

Crankcase heater must be energized at all times to prevent compressor damage due to refrigerant migration. Energize crankcase heater 24 hours before unit start-up by setting thermostat so that there is no cooling demand (to prevent compressor from cycling) and apply power to unit.

D-BLOWER COMPARTMENT

IMPORTANT

Three phase scroll compressors must be phased sequentially for correct compressor and blower rotation. Follow "COOLING START-UP" section of installation instructions to ensure proper compressor and blower operation.

Units are equipped with a variable speed, direct drive blower. The installer is able to enter the design-specified supply air CFM into the Unit Controller for optimal efficiency. The Unit Controller calibrates the supply air volume which eliminates the need to manually take duct static measurements.

Indoor Blower Motor B3

All direct drive blower motors are electronically commutated, brushless, DC motors. CFM adjustments are made by changing Unit Controller parameters via the service app. Motors are equipped with sealed ball bearings. All motor specifications are listed in the SPECIFICATIONS (table of contents) in the front of this manual. Motors come with premounted aluminum impellers.

1-Blower Operation

Refer to the Unit Controller Setup Guide to energize blower. Use the mobile service app menu; see RTU MENU > COMPONENT TEST > BLOWER > START TEST.

2-Determining Unit CFM

- 1 - The following measurements must be made with air filters in place.

WARNING

- 1-Make sure that unit is installed in accordance with the installation instructions and applicable codes.
- 2-Inspect all electrical wiring, both field- and factory-installed, for loose connections. Tighten as required.
- 3-Check to ensure that refrigerant lines do not rub against the cabinet or against other refrigerant lines.
- 4-Check voltage at disconnect switch. Voltage must be within range listed on nameplate. If not, consult power company and have voltage condition corrected before starting unit.
- 5-Make sure filters are new and in place before start-up.

Direct-drive motor may not immediately stop when power is interrupted to the Unit Controller. Disconnect unit power before opening the blower compartment. The Controller's digital inputs must be used to shut down the blower. See Unit Controller manual for operation sequences.

- 2 - With all access panels in place, measure static pressure external to unit (from supply to return). Blower performance data is based on static pressure readings taken in locations shown in FIGURE 10.

Note - Static pressure readings can vary if not taken where shown.

- 3 - Measure the indoor blower wheel RPM.
- 4 - Referring to the Blower Data tables, use static pressure and RPM readings to determine unit CFM. Use the Accessory Air Resistance tables when installing units with any of the options or accessories listed. Refer to TABLE 3 for minimum airflow when electric heat is installed.
- 5 - From the mobile service app, use TEST & BALANCE > BLOWER menu to modify the following blower parameters:

- HEATING HIGH CFM

This is the percentage of torque for blower heating speed.

- HEATING LOW CFM

This is the percentage of torque for blower heating low speed on single phase gas heating units only.

- COOLING HIGH CFM

This is the percentage of torque for blower cooling high speed.

- COOLING LOW CFM

This is the percentage of torque for blower cooling low speed and vent speed for standard static blowers (all units).

- VENTILATION CFM

This is the percentage of torque for high static blower ventilation speed.

TABLE 3

ELECTRIC HEAT MINIMUM AIRFLOW

kW	CFM	
	Direct Drive	Direct Drive (Impeller-Style)
7.5	600	1200
15	1100	1500
22.5	1600	2000

3-Adjusting Unit CFM

The supply CFM can be adjusted by changing Unit Controller settings. Refer to TABLE 3 for menu paths and default settings. Record any CFM changes on the parameter settings label located on the inside of the compressor access panel.

IMPORTANT - The default value for Cooling Low CFM is lower than a traditional single- or two-speed blower. If operating the unit with a 2- or 3-stage controller (2- or 3-stage thermostat, DDC controller, etc.), it is recommended to increase the Cooling Low CFM default value to a suitable level for part load cooling (typically 60% of full load CFM).

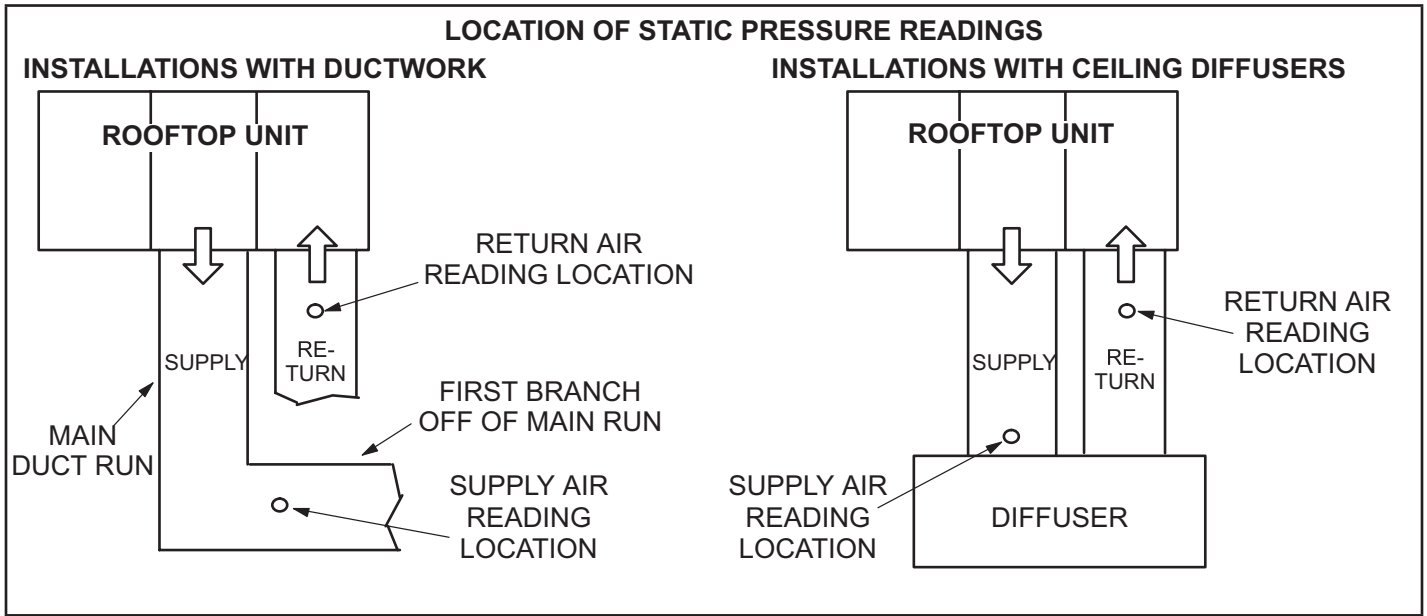

FIGURE 10

**TABLE 4
BLOWER PARAMETER SETTINGS - 581102-01**

Parameter	Field Setting	Description
Note: Any changes to Smoke CFM setting must be adjusted before the other CFM settings. Use SETTINGS > RTU OPTIONS > EDIT PARAMETERS = 12 for EBM, 6 for ECM		
BLOWER SMOKE CFM	%	Percentage of torque for blower smoke speed.
SETUP > TEST & BALANCE > BLOWER		
BLOWER HEATING HIGH CFM	%	Percentage of torque for blower heating high speed.
BLOWER HEATING LOW CFM	%	Percentage of torque for blower heating low speed (P volt gas heat only).
BLOWER COOLING HIGH CFM	%	Percentage of torque for blower cooling high speed.
BLOWER COOLING LOW CFM	%	Percentage of torque for blower cooling low speed and vent speed for standard static blowers.
BLOWER VENTILATION CFM	%	Percentage of torque for high static blower ventilation speed.
SETUP > TEST & BALANCE > DAMPER		
BLOWER HIGH CFM DAMPER POS %	%	Minimum damper position for high speed blower operation. Default 0%.
BLOWER LOW CFM DAMPER POS %	%	Minimum damper position for low speed blower operation. Default 0%.
POWER EXHAUST DAMPER POS %	%	Minimum damper position for low power exhaust operation. Default 50%.
SETTINGS > RTU OPTIONS > EDIT PARAMETERS = 216		
POWER EXHAUST DEADBAND %	%	Deadband % for power exhaust operation. Default 10%.
SETTINGS > RTU OPTIONS > EDIT PARAMETERS = 10 (Applies to Thermostat Mode ONLY)		
FREE COOLING STAGE-UP DELAY	sec	Number of seconds to hold blower at low speed before switching to blower at high speed. Default 300 seconds.

Installer: Record any parameter changes under "Field Setting" column. Settings need to be recorded by installer for use when Unit Controller is replaced or reprogrammed.

C-ELECTRIC HEAT COMPONENTS

Electric heat match-ups are found in the ELECTRICAL DATA tables. See table of contents.

All electric heat sections consist of electric heating elements exposed directly to the air stream. See FIGURE 11. See FIGURE 12 for vestibule parts arrangement.

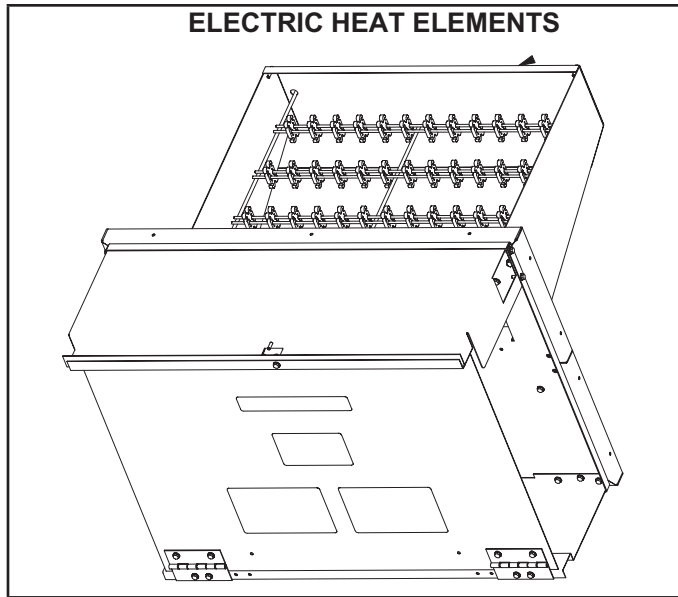

FIGURE 11

1-Contactors K15, K16

All contactors are double break and either single, double or three pole (see diagram) and equipped with a 24VAC coil. The coils in the K15 and K16 contactors are energized by the indoor thermostat. In all units K15 energizes the heating elements, while in the 22.5 kW units, K15 and K16 energize the heating elements simultaneously.

2-High Temperature Limits S15 (Primary)

S15 is a SPST N.C. auto-reset thermostat located on the back panel of the electric heat section above the heating elements. S15 is the high temperature limit for the electric heat section. When S15 opens, indicating a problem in the system, contactor K15 is de-energized (including K16 in 22.5 kW units). When K15 is de-energized, all stages of heat are de-energized. See TABLE 5 for S15 set points. Set points are factory set and not adjustable.

TABLE 5		
Unit kW (Voltage)	S15 Opens ° F	S15 Closes ° F
7.5 kW (P, Y, G, J)	160	120
15 kW(P, G, J)	160	120
15 kW (Y)	170	130
22.5 kW (Y)	150	110
22.5 kW (Y, G, J)	160	120

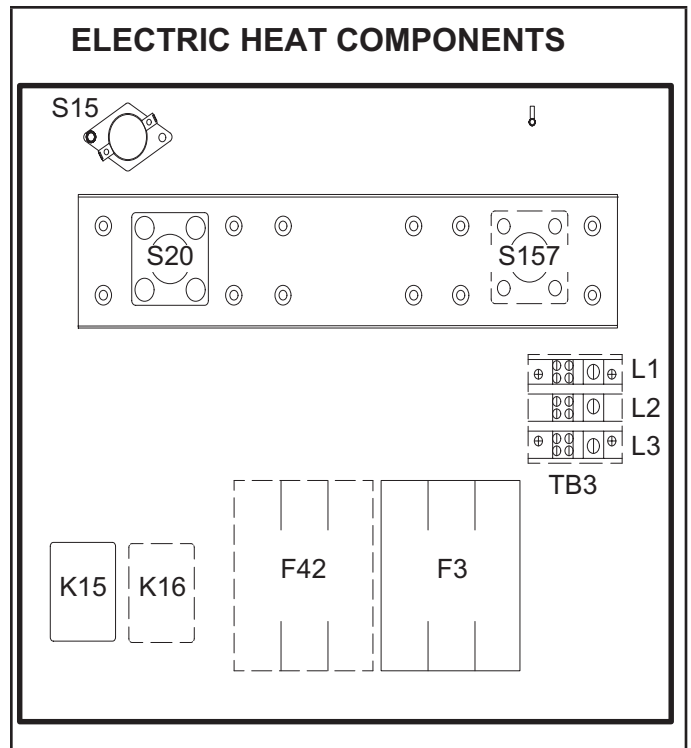

FIGURE 12

3-High Temperature Limit S20 and S157 (Secondary)

S20 and S157 are SPST N.C. manual-reset thermostats. S20 and S157 are wired in series with the heating elements. See E1EH wiring diagrams. When S20 or S157 open, power is interrupted to the heating elements which are wired in series with the limits. K15/K16 are only de-energized when S15 opens. When the contactors are de-energized, all stages of heat are de-energized. The thermostat is factory set to open at $220\text{F} \pm 6^\circ\text{F}$ ($104\text{C} \pm 3.3^\circ\text{C}$) on a temperature rise and can be manually reset when temperature falls below 160°F (71.0C). See figure 10 for location.

4-Terminal Strip TB2

Terminal strip TB2 is used for single point power installations only. TB2 distributes power to TB3. Units with multi-point power connections will not use TB2.

5-Terminal Strip TB3

P and Y voltage units are equipped with terminal strip TB3. Electric heat line voltage connections are made to TB3, which distributes power to the electric heat components and is located on the vestibule. See FIGURE 12.

6-Heating Elements HE1 through HE6

Heating elements are composed of helix wound bare nichrome wire exposed directly to the air stream. Three elements are connected in a three-phase arrangement. The elements in 208/230V units are connected in a “Delta” arrangement. Elements in 460 and 575V units are connected in “Wye” arrangement. Each stage is energized independently by the corresponding contactors located on the electric heat vestibule panel. Once energized, heat transfer is instantaneous. High temperature protection is provided by primary and redundant high temperature limits and overcurrent protection is provided by fuses.

7-Fuse F42/F3

Fuse F3/F42 is housed in a fuse block which holds two or three fuses. Each F42/F3 fuse is connected in series with each leg of electric heat. FIGURE 12 and TABLE 6 show the fuses used with each electric heat section.

8-Unit Fuse Block & Fuse F4

Three line voltage fuses F4 provide short circuit and ground fault protection to all cooling components in the LHT units with electric heat. The fuses are rated in accordance with the amperage of the cooling components. The F 4 fuse block is located inside a sheet metal enclosure

II-PLACEMENT AND INSTALLATION

Make sure the unit is installed in accordance with the installation instructions and all applicable codes. See accessories section for conditions requiring use of the optional roof mounting frame (T1CURB-AN or C1CURB-AN).

III-START UP - OPERATION

A-Preliminary and Seasonal Checks

- 1 - Make sure the unit is installed in accordance with the installation instructions and applicable codes.
- 2 - Inspect all electrical wiring, both field and factory installed for loose connections. Tighten as required. Refer to unit diagram located on inside of unit compressor access panel.
- 3 - Check to ensure that refrigerant lines are in good condition and do not rub against the cabinet or other refrigerant lines.
- 4 - Check voltage at the disconnect switch. Voltage must be within the range listed on the nameplate. If not, consult the power company and have the voltage corrected before starting the unit.
- 5 - Recheck voltage and amp draw with unit running. If voltage is not within range listed on unit nameplate, stop unit and consult power company. Refer to unit nameplate for maximum rated load amps.

TABLE 6

Unit	Voltage / Phase	Fuse	F42	F3
			Quantity	Quantity
E1EH0050	208/230V-1P	30 A-250V		2
E1H0075	208/230V-1P	40 A-250V		2
	208/230V-3P	25 A-250V		3
	460V-3P	15 A-600V		3
	575V-3P	15 A-600V		3
E1EH0100	208V/230V-1P	30 A-250V	2	2
E1EH150	208/230V-1P	40 A 250V	2	2
	208/230V-3P	50 A 250V		3
	460V-3P	25 A-600V		3
	575V-3P	20 A-600V		3
E1EH0225	208V/230V-1P	40 A 250V	3	3
	208/230V-3P	45 A-250V	3	3
	460V-3P	35 A-600V		3
	575V-3P	30 A-600V		3
E1EH0300	208/230V-3P	60 A250V	3	3
	460V-3P	50 A600V		3
	575V-3P	40 A 600V		3

B-Cooling Start up

1-Operation

- 1 - Initiate full load cooling operation using the following mobile service app menu path:
RTU>COMPONENT TEST> COOLING>COOLING STAGE 2
- 2 - Units contain one refrigerant circuit or stage.
- 3 - Unit is charged with R-454B refrigerant. See unit rating plate for correct amount of charge.
- 4 - Refer to charging section method to check refrigerant charge.

C-Electric Heat Start Up

Optional electric heat will stage on and cycle with thermostat demand. See electric heat wiring diagram on unit for sequence of operation.

IV-CHARGING

Refrigerant Charge R-454B		
Unit	M _c (lbs)	M _c (kg)
LHT036	13.56	6.15
LHT048	13.94	6.32
LHT060	16.13	7.31
LHT072	13.63	6.18

A-Refrigerant Charge and Check - Fin/Tube

WARNING-Do not exceed nameplate charge under any condition.

This unit is factory charged and should require no further adjustment. If the system requires additional refrigerant, reclaim the charge, evacuate the system, and add required nameplate charge.

When breaking into the refrigerant circuit to make repairs – or for any other purpose – conventional procedures shall be used. However, for flammable refrigerants it is important that best practice be followed and, since flammability is a consideration, the following procedure shall be adhered to:

- Safely remove refrigerant following local and national regulations,
- Evacuate the circuit,
- Purge the circuit with inert gas,
- Evacuate,
- Purge with inert gas,
- Open the circuit

The refrigerant charge shall be recovered into the correct recovery cylinders if venting is not allowed by local and national codes. For appliances containing flammable refrigerants, the system shall be purged with oxygen-free nitrogen to render the appliance safe for flammable refrigerants. This process might need to be repeated several times. Compressed air or oxygen shall not be used for purging refrigerant systems.

Refrigerant purging shall be achieved by breaking the vacuum in the system with oxygen-free nitrogen and continuing to fill until the working pressure is achieved, then venting to atmosphere, and finally pulling down to a vacuum.

This process shall be repeated until no refrigerant is within the system. When the final oxygen-free nitrogen charge is used, the system shall be vented down to atmospheric pressure to enable work to take place. Ensure that the outlet for the vacuum pump is not close to any potential ignition sources and that ventilation is available.

In addition to conventional charging procedures, the following requirements shall be followed.

- Ensure that contamination of different refrigerants does not occur when using charging equipment. Hoses or lines shall be as short as possible to minimize the amount of refrigerant contained in them.
- Cylinders shall be kept in an appropriate position according to the instructions.
- Ensure that the refrigerating unit is earthed prior to charging the system with refrigerant.
 - Label the system when charging is complete (if not already).
 - Extreme care shall be taken not to overfill the refrigerating unit.

Prior to recharging the system, it shall be pressure-tested with the appropriate purging gas. The system shall be leak-tested on completion of charging but prior to commissioning. A follow up leak test shall be carried out prior to leaving the site.

When removing refrigerant from a system, either for servicing or decommissioning, it is recommended good practice that all refrigerants are removed safely.

- When transferring refrigerant into cylinders, ensure that only appropriate refrigerant recovery cylinders are employed. Ensure that the correct number of cylinders for holding the total system charge is available. All cylinders to be used are designated for the recovered refrigerant and labelled for that refrigerant (i. e. special cylinders for the recovery of refrigerant). Cylinders shall be complete with pressure-relief valve and associated shut-off valves in good working order. Empty recovery cylinders are evacuated and, if possible, cooled before recovery occurs.
- The recovery equipment shall be in good working order with a set of instructions concerning the equipment that is at hand and shall be suitable for the recovery of all appropriate refrigerants including, when applicable, flammable refrigerants. In addition, a set of calibrated weighing scales shall be available and in good working order. Hoses shall be complete with leak-free disconnect couplings and in good condition. Before using the recovery machine, check that it is in satisfactory working order, has been properly maintained and that any associated electrical components are sealed to prevent ignition in the event of a refrigerant release. Consult manufacturer if in doubt.

- The recovery equipment shall be in good working order with a set of instructions concerning the equipment that is at hand and shall be suitable for the recovery of all appropriate refrigerants including, when applicable, flammable refrigerants. In addition, a set of calibrated weighing scales shall be available and in good working order. Hoses shall be complete with leak-free disconnect couplings and in good condition. Before using the recovery machine, check that it is in satisfactory working order, has been properly maintained and that any associated electrical components are sealed to prevent ignition in the event of a refrigerant release. Consult manufacturer if in doubt.
- The recovered refrigerant shall be returned to the refrigerant supplier in the correct recovery cylinder, and the relevant waste transfer note arranged. Do not mix refrigerants in recovery units and especially not in cylinders.
- If compressors or compressor oils are to be removed, ensure that they have been evacuated to an acceptable level to make certain that flammable refrigerant does not remain within the lubricant. The evacuation process shall be carried out prior to returning the compressor to the suppliers. Only electric heating to the compressor body shall be employed to accelerate this process. When oil is drained from a system, it shall be carried out safely.

Prior to recharging the system, it shall be pressure tested with the appropriate purging gas. The system shall be leak-tested on completion of charging but prior to commissioning. A follow up leak test shall be carried out prior to leaving the site.

NOTE - System charging is not recommended below 60F (15C). In temperatures below 60F (15C), the charge must be weighed into the system.

If weighing facilities are not available, or to check the charge, use the following procedure:

- 1 - Attach gauge manifolds and operate unit in cooling mode on **HIGH SPEED** with economizer disabled until system stabilizes (approximately five minutes). Make sure outdoor air dampers are closed.

Note - Use mobile service app menu path RTU MENU > COMPONENT TEST > COOLING > COOLING STAGE 2

- 2 - Use a thermometer to accurately measure the outdoor ambient temperature.
- 3 - Apply the outdoor temperature to TABLE 7 through TABLE 10 to determine normal operating pressures. Pressures are listed for sea level applications at 80°F dry bulb and 67°F wet bulb return air.
- 4 - Compare the normal operating pressures to the pressures obtained from the gauges. Minor variations in these pressures may be expected due to differences in installations. Significant differences could mean that the system is not properly charged or that a problem exists with some component in the system. **Correct any system problems before proceeding.**

- 5 - If discharge pressure is high, remove refrigerant from the system. If discharge pressure is low, add refrigerant to the system.
 - Add or remove charge in increments.
 - Allow the system to stabilize each time refrigerant is added or removed.
- 6 - Use one of the following charge verification methods along with the normal operating pressures to confirm readings.

Charge Verification - Approach Method - AHRI Testing

- 1 - Using the same thermometer, compare liquid temperature to outdoor ambient temperature.

Approach Temperature = Liquid temperature (at condenser outlet) minus ambient temperature.

- 2 - Approach temperature should be 3.8°F ± 1 (2.1°C ± 0.5). An approach temperature greater than this value indicates an under-charge. An approach temperature less than this value indicates an overcharge.
- 3 - The approach method is not valid for grossly over or undercharged systems. Use TABLE 11 as a guide for typical operating pressures.

TABLE 7 581066-02 036 NORMAL OPERATING PRESSURES		
Outdoor Coil Entering Air Temp	Discharge ± 10 psig	Suction ± 5 psig
65°F	226	137
75°F	261	139
85°F	302	141
95°F	349	143
100°F	395	145
115°F	460	148

TABLE 8 581067-02 048 NORMAL OPERATING PRESSURES		
Outdoor Coil Entering Air Temp	Discharge ± 10 psig	Suction ± 5 psig
65°F	235	126
75°F	272	127
85°F	314	129
95°F	359	130
100°F	401	132
115°F	456	135

TABLE 9 581068-02 060 NORMAL OPERATING PRESSURES		
Outdoor Coil Entering Air Temp	Discharge ± 10 psig	Suction ± 5 psig
65°F	244	124
75°F	287	132
85°F	330	135
95°F	377	137
100°F	430	140
115°F	491	143

TABLE 10 581240-01 072 NORMAL OPERATING PRESSURES		
Outdoor Coil Entering Air Temp	Discharge ± 10 psig	Suction ± 5 psig
65°F	258	125
75°F	299	128
85°F	342	130
95°F	387	133
100°F	444	135
115°F	498	137

TABLE 11 SUBCOOLING TEMPERATURE		
Unit	Outdoor Coil Entering Temp	Subcooling Temp
036	95°F	8.5°F ± 1 (4.7°C ± 0.5)
048	95°F	8.4°F ± 1 (4.7°C ± 0.5)
060	95°F	9.6°F ± 1 (5.3°C ± 0.5)
072	95°F	6.8°F ± 1 (3.8°C ± 0.5)

V- SYSTEMS SERVICE CHECKS

LHT units are factory charged and require no further adjustment; however, charge should be checked periodically using the approach method. The approach method compares actual liquid temperature with the outdoor ambient temperature. See section IV- CHARGING.

NOTE-When unit is properly charged discharge line pressures should approximate those in TABLE 7 through TABLE 10.

VI-MAINTENANCE

The unit should be inspected once a year by a qualified service technician.

IMPORTANT

Label all wires prior to disconnection when servicing controls. Wiring errors can cause improper and dangerous operation. Verify proper operation after servicing.

WARNING

Any service personnel installing, decommissioning, or performing maintenance on the unit must be properly trained with A2L refrigerants

Prior to beginning work on systems containing refrigerant to ensure the risk of ignition is minimized:

- All work shall be undertaken under a controlled procedure so as to minimize the risk of a flammable gas or vapor being present while the work is being performed.
- The area shall be checked with an appropriate refrigerant detector prior to and during work, to ensure the technician is aware of potentially toxic or flammable atmospheres. Ensure that the leak detection equipment being used is suitable for use with all applicable refrigerants, i. e. non-sparking, adequately sealed or intrinsically safe.
- If any hot work is to be conducted on the refrigerating equipment or any associated parts, the appropriate fire extinguishing equipment shall be available to hand. Have a dry powder or CO2 fire extinguisher adjacent to the charging area.
- No person carrying out work in relation to a refrigerating system which involves exposing any pipe work shall use any sources of ignition in such a manner that it may lead to the risk of fire or explosion. All possible ignition sources, including cigarette smoking, should be kept sufficiently far away from the site of installation, repairing, removing and disposal, during which refrigerant can possibly be released to the surrounding space. Prior to work taking place, the area around the equipment is to be surveyed to make sure that there are no flammable hazards or ignition risks. "No Smoking" signs shall be displayed.
- Ensure that the area is in the open or that it is adequately ventilated before breaking into the system or conducting any hot work.

A degree of ventilation shall continue during the period that the work is carried out. The ventilation should safely disperse any released refrigerant and preferably expel it externally into the atmosphere.

- Where electrical components are being changed, service technicians shall be fit for the purpose and to the correct specification. At all times the manufacturer's maintenance and service guidelines shall be followed. If in doubt, consult the manufacturer's technical department for assistance. The following checks shall be applied to installations using flammable refrigerants as applicable:
 - 1 - The actual refrigerant charge is in accordance with the room size within which the refrigerant containing parts are installed.
 - 2 - The ventilation machinery and outlets are operating adequately and are not obstructed.
 - 3 - If an indirect refrigerating circuit is being used, the secondary circuit shall be checked for the presence of refrigerant.
 - 4 - Markings on the equipment should be visible and legible. Markings and signs that are illegible shall be corrected.
 - 5 - Refrigerating pipes or components are installed in a position where they are unlikely to be exposed to any substance which may corrode refrigerant containing components, unless the components are constructed of materials which are inherently resistant to being corroded or are suitably protected against being so corroded.
- For systems containing refrigerant all repair and maintenance to electrical components shall include initial safety checks and component inspection procedures such as that capacitors are discharged in a safe manner to avoid possibility of sparking; that no live electrical components and wiring are exposed while charging, recovering, or purging the system, and that there is continuity of earth bonding. If a fault exists that could compromise safety, then no electrical supply shall be connected to the circuit until it is satisfactorily dealt with. If the fault cannot be corrected immediately but it is necessary to continue operation, an adequate temporary solution shall be used that is reported to the owner of the equipment, so all parties are advised.

NOTE - Sealed electrical components shall be replaced, not repaired.

NOTE - Intrinsically safe components must be replaced, not repaired.

- Under no circumstances shall potential sources of ignition be used in the searching for or detection of refrigerant leaks. A halide torch (or any other detector using a naked flame) shall not be used. Electronic leak detectors may be used to detect refrigerant leaks but, in the case of flammable refrigerants, the sensitivity may not be adequate, or may need re-calibration. (Detection equipment shall be calibrated in a refrigerant-free area.) Ensure that the detector is not a potential source of ignition and is suitable for the refrigerant used. Leak detection equipment shall be set at a percentage of the LFL of the refrigerant and shall be calibrated to the refrigerant employed, and the appropriate percentage of gas (25 % maximum) is confirmed. Leak detection fluids are also suitable for use with most refrigerants but the use of detergents containing chlorine shall be avoided as the chlorine may react with the refrigerant and corrode the copper pipe-work. If a leak is suspected, all naked flames shall be removed/extinguished. If a leakage of refrigerant is found which requires brazing, all of the refrigerant shall be recovered from the system, or isolated (by means of shut off valves) in a part of the system remote from the leak.
- When breaking into the refrigerant circuit to make repairs – or for any other purpose – conventional procedures shall be used. However, for flammable refrigerants it is important that best practice be followed, since flammability is a consideration. The following procedure shall be adhered to:
 - a. Safely remove refrigerant following local and national regulations,
 - b. Evacuate the circuit,
 - c. Purge the circuit with inert gas,
 - d. Evacuate,
 - e. Purge with inert gas,
 - f. Open the circuit.
- The refrigerant charge shall be recovered into the correct recovery cylinders if venting is not allowed by local and national codes. For appliances containing flammable refrigerants, the system shall be purged with oxygen-free nitrogen to render the appliance safe for flammable refrigerants. This process might need to be repeated several times. Compressed air or oxygen shall not be used for purging refrigerant systems. Refrigerant purging shall be achieved by breaking the vacuum in the system with oxygen-free nitrogen and continuing to fill until the working pressure is achieved, then venting to atmosphere, and finally pulling down to a vacuum. This process shall be repeated until no refrigerant is within the system. When the final oxygen-free nitrogen charge is used, the system shall be vented down to atmospheric pressure to enable work to take place. Ensure that the outlet for the vacuum pump is not close to any potential ignition sources and that ventilation is available

! IMPORTANT

Label all wires prior to disconnection when servicing controls. Wiring errors can cause improper and dangerous operation. Verify proper operation after servicing.

A-Filters

Units are equipped with temporary filters which must be replaced prior to building occupation. See FIGURE 13. All units have 20 X 20 X 2 in. (508 X 508 X 51mm) filters. Refer to local codes or appropriate jurisdiction for approved filters.

NOTE-Filters must be U.L.C. certified or equivalent for use in Canada.

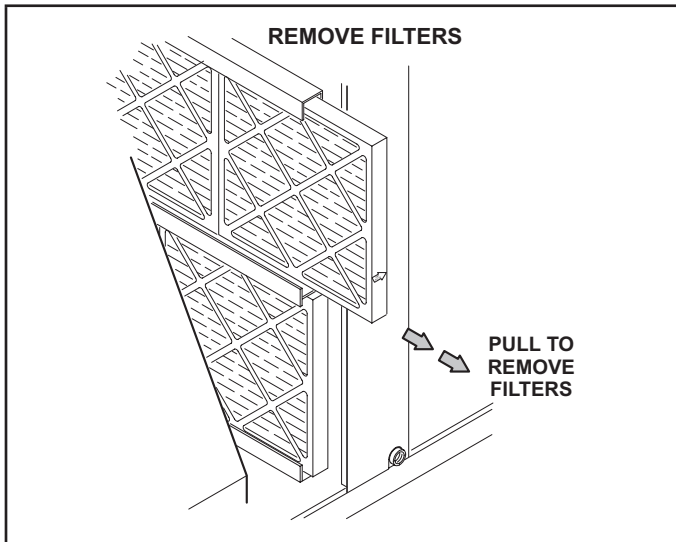

FIGURE 13

B-Lubrication

All motors are lubricated at the factory. No further lubrication is required.

C-Evaporator Coil

Inspect and clean coil at beginning of each cooling season. Clean using mild detergent or commercial coil cleanser.

Flush coil and condensate drain with water taking care not to get insulation, filters and return air ducts wet.

D-Condenser Coil

Clean condenser coil annually with detergent or commercial coil cleaner and inspect monthly during the cooling season.

Condenser coils are made of single and two formed slabs. On units with two slabs, dirt and debris may become trapped between the slabs. To clean between slabs, carefully separate coil slabs and wash them thoroughly. See FIGURE 14. Flush coils with water following cleaning.

Note - Remove all screws and gaskets prior to cleaning procedure and replace upon completion.

E-Supply Blower Wheel

Annually inspect supply air blower wheel for accumulated dirt or dust. Turn off power before attempting to remove access panel or to clean blower wheel.

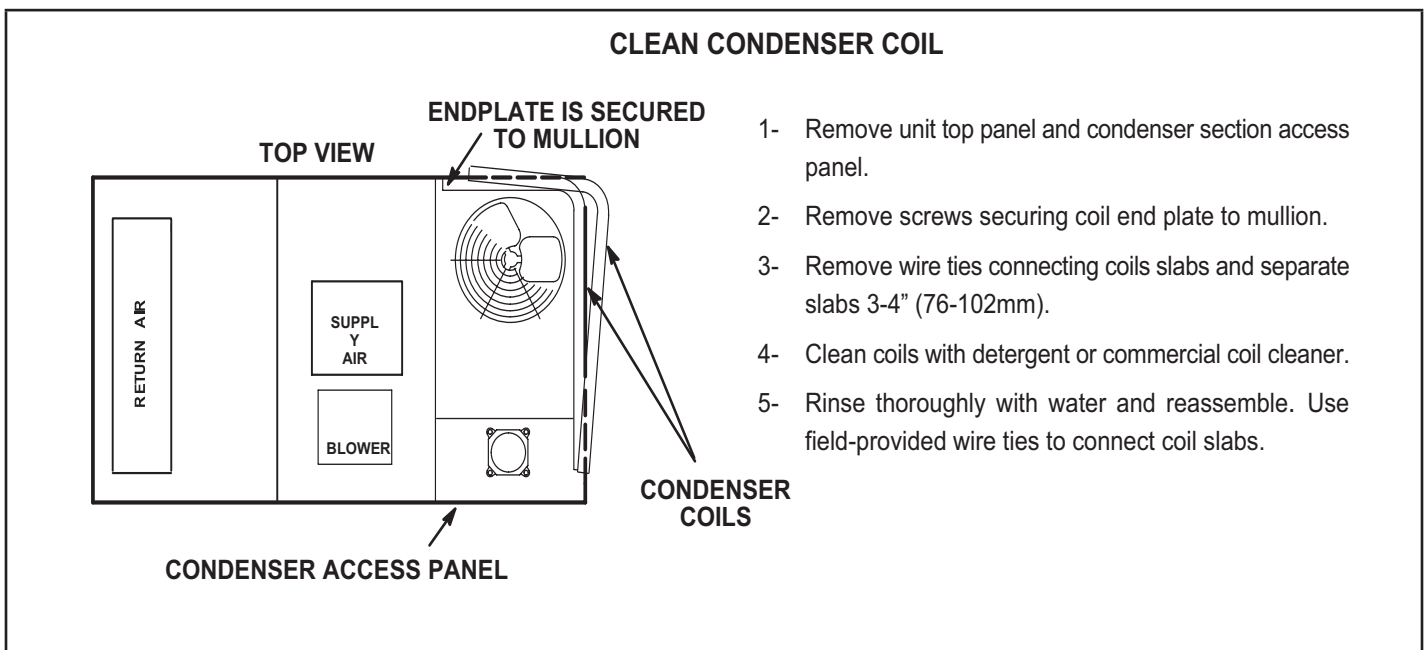

FIGURE 14

VII-ACCESSORIES

The accessories section describes the application of most of the optional accessories which can be factory- or field-installed to the LHT units.

A-C1/T1CURB

When installing the LHT units on a combustible surface for downflow discharge applications, the C1/T1CURB 8 inch, 14-inch, 18 inch or 24-inch height roof mounting frame is used. The roof mounting frames are recommended in all other applications but not required. If the LHT units are not mounted on a flat (roof) surface, they MUST be supported under all edges and under the middle of the unit to prevent sagging. The units MUST be mounted level within 1/16" per linear foot or 5mm per meter in any direction. The assembled mounting frame is shown in FIGURE 15. Refer to the roof mounting frame installation instructions for details of proper assembly and mounting. The roof mounting frame MUST be squared to the roof and level before mounting. Plenum system MUST be installed before the unit is set on the mounting frame. Typical roof curbing and flashing is shown in FIGURE 16. Refer to the roof mounting frame installation instructions for proper plenum construction and attachment.

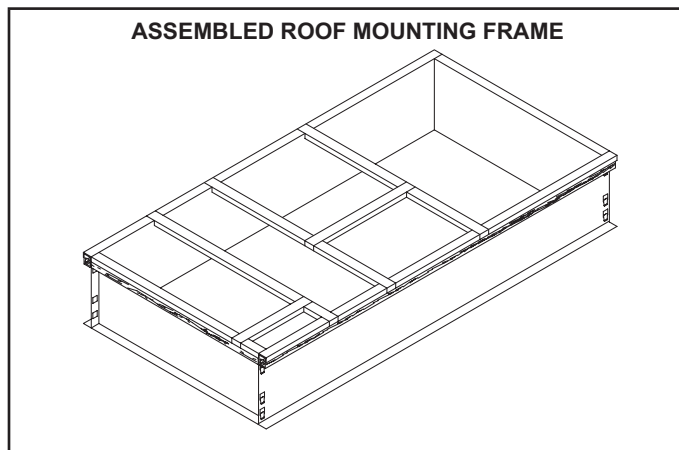

FIGURE 15

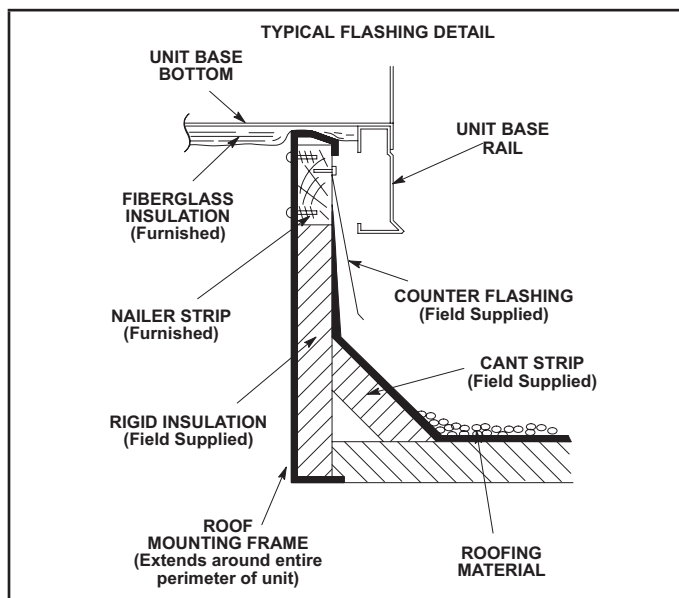

FIGURE 16

B-Transitions

Optional supply/return transitions are available for use with the LHT units (refer to EHB for appropriate transition model). Transition must be installed in the C1/T1CURB mounting frame before mounting the unit to the frame. Refer to the manufacturer's instructions included with the transition for detailed installation procedures.

C-Outdoor Air Dampers

Optional outdoor air dampers are available for use with the LHT units in both manually operated (FIGURE 17) and motorized (FIGURE 18) options (refer to EHB for appropriate transition model). Both sets include the outdoor air hood. The manual damper is set at a fixed point to bring outside air into the building anytime the blower is operating. The motorized damper opens when the blower is operating and the thermostat is sending an occupied signal to the Unit Controller. If the thermostat signal is unoccupied, the motorized damper will not open. Washable filter supplied with the outdoor air dampers can be cleaned with water and a mild detergent. It should be sprayed with Filter Handicoater when dry prior to re-installation. Filter Handicoater is R.P. Products coating no. 418 and is available as Part No. P-8-5069.

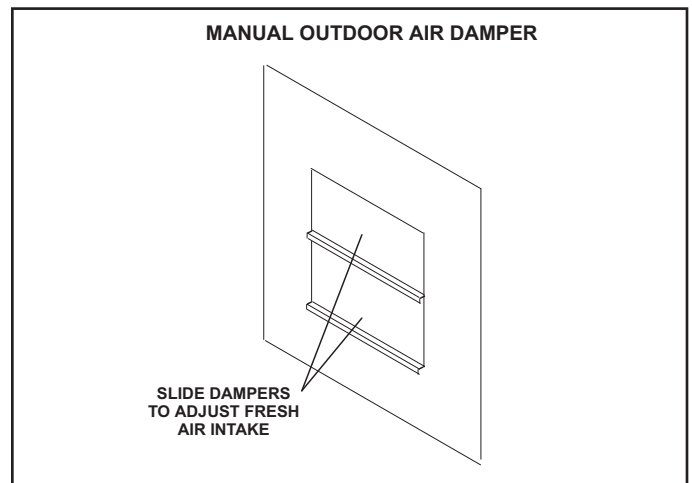

FIGURE 17

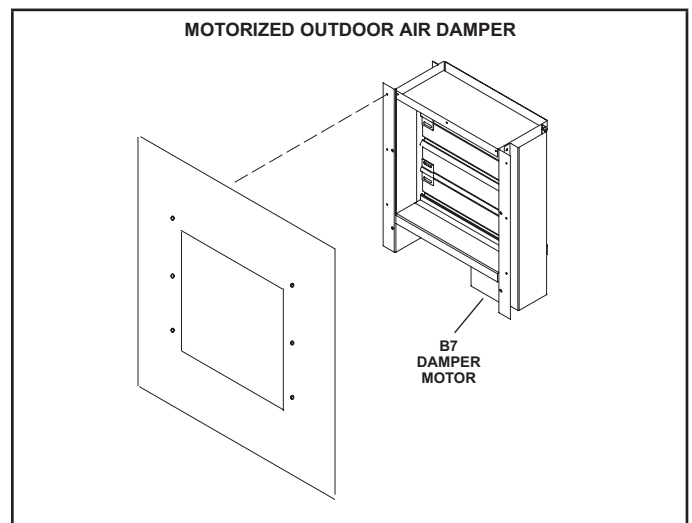

FIGURE 18

D-Supply and Return Diffusers

Optional flush mount diffuser/return FD9-65 and FD11-95 and extended mount diffuser/return RTD9-65 and RTD11-95 are available for use with all LHT units. Refer to manufacturer's instructions included with transition for detailed installation procedures.

E-Economizer

(Optional Field- or Factory-Installed)

The economizer uses outdoor air for free cooling when temperature is suitable. See FIGURE 19.

When outdoor air is suitable, the Unit Controller will modulate the economizer dampers to maintain 55°F discharge air (RT6). Refer to unit controller manual for menu paths to adjust economizer setpoints

Sensors

Units are equipped with the following factory-installed, CEC Title 24 approved sensors:

RT17 - Outside Air Temperature

RT16 - Return Air Temperature

RT6 - Discharge Air Temperature

See FIGURE 20 for sensor location.

Optional field-provided sensors may be used instead of unit sensors to determine whether outdoor air is suitable for free cooling. Refer to TABLE 11 TEMP OFFSET is the default mode.

Note - Network OAS signal and California Title 24 Compliance options use either TEMPERATURE OFFSET or TEMPERATURE SETPT mode.

Minimum Position

The Unit Controller will move the dampers to minimum position during the following:

Ventilation mode (G demand only)

Outdoor air is NOT suitable for free cooling

The damper position will vary linearly with blower speed based on the damper position settings for high and low CFM. Damper calibration must be initiated in the mobile service app to set high and low damper positions.

GED (Gravity Exhaust / Barometric Relief Dampers) Field-Installed Option

The GED is located in the economizer except in downflow applications or when a PEF (power exhaust fan) is NOT installed. In horizontal airflow applications or when a PEF is installed, the GED is located in the exhaust air hood.

Horizontal Air Discharge Economizers

The economizer is located in the unit the same as downflow applications but note the position of the return air duct. The duct attaches to a duct transition and duct inlet on the end of the unit. An optional GED is located in the duct transition. See FIGURE 21.

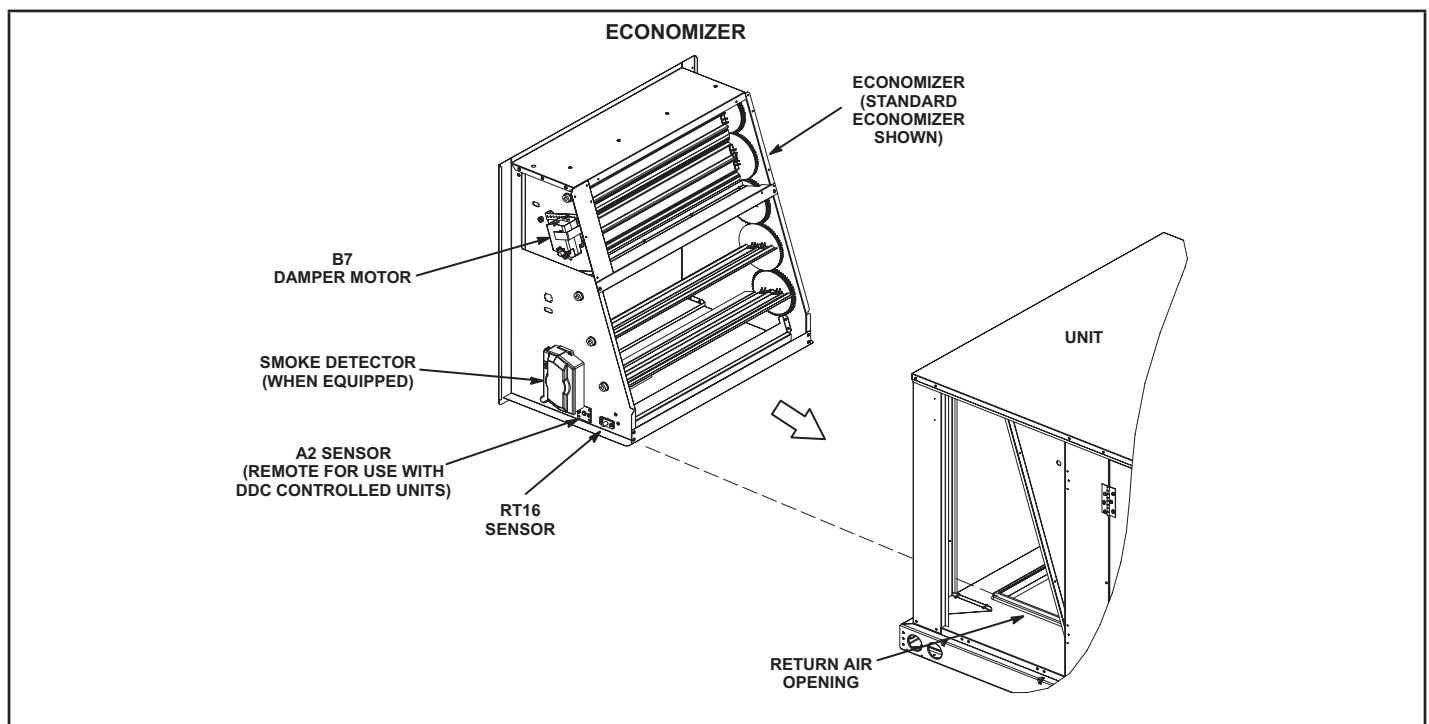

FIGURE 19

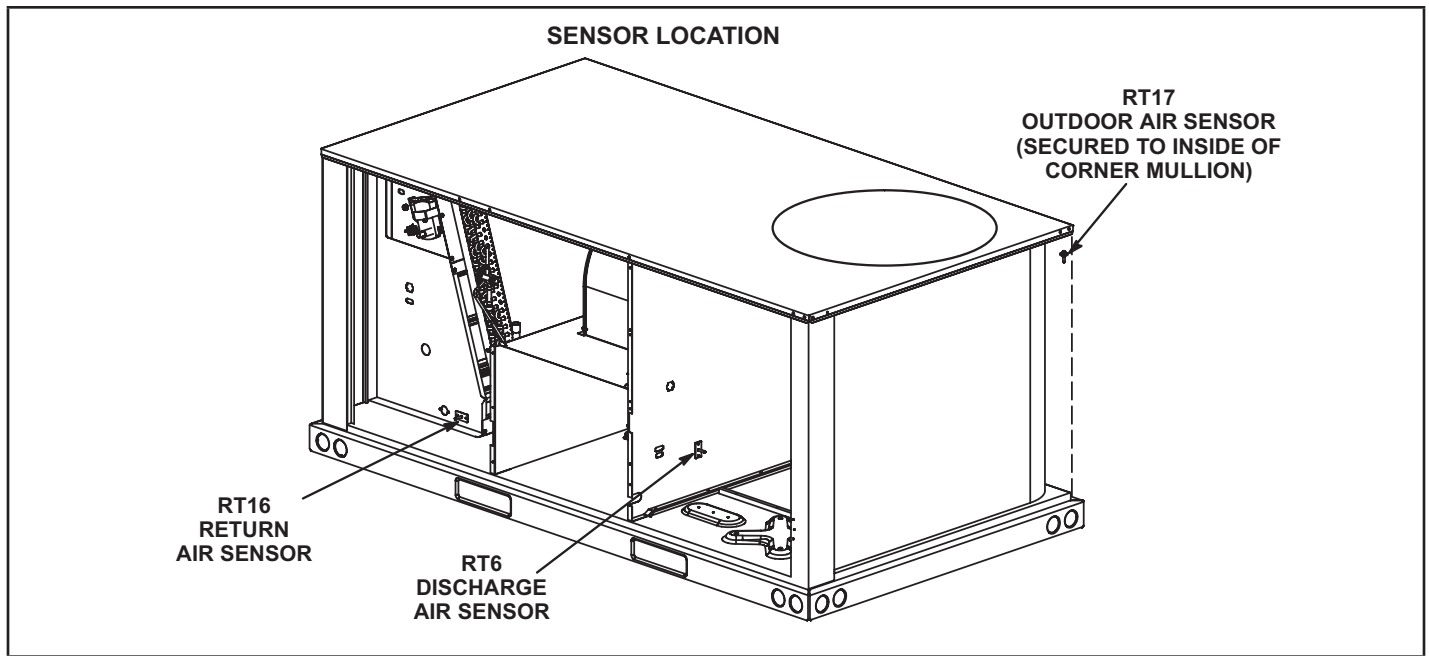

FIGURE 20

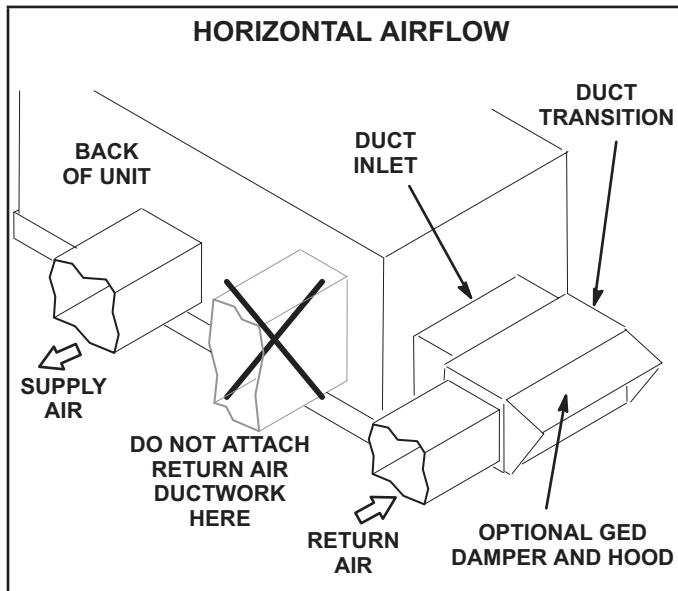

FIGURE 21

F-Power Exhaust Relay K6 (power exhaust units)

Power exhaust relay K65 is a DPDT relay with a 24VAC coil. K65 is used in all LHT units equipped with the optional power exhaust dampers. K65 is energized by the Unit Controller after the economizer dampers reach 50% open (adjustable). When K65 closes, exhaust fan B10 is energized.

G-Power Exhaust Fans

Optional power exhaust fans are available for use with the LHT units to provide exhaust air pressure relief (refer to EHB for appropriate transition model). See FIGURE 22 and installation instructions for more detail.

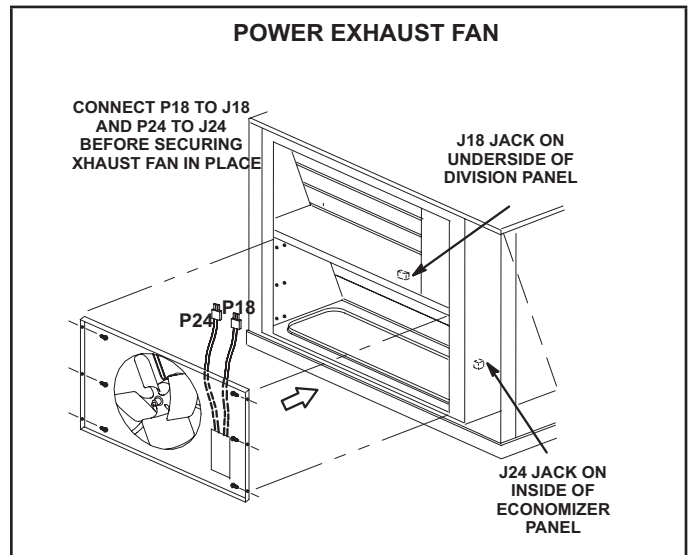

FIGURE 22

H-Optional UVC Lights

The germicidal light emits ultraviolet (UVC) energy that has been proven effective in reducing microbial life forms (viruses, bacteria, yeasts, and molds) in the air.

UVC germicidal lamps greatly reduce the growth and proliferation of mold and other bio-aerosols (bacteria and viruses) on illuminated surfaces.

Germicidal lamps are NOT intended to be used for removal of active mold growth. Existing mold growth must be appropriately removed PRIOR to installation of the germicidal lamp.

Refer closely to UVC light installation instruction warnings when servicing units.

**TABLE 12
ECONOMIZER MODES AND SETPOINT**

Free Cooling Mode	Free Cooling Setpoint	Field- Provide Sensors	Dampers will modulate to 55°F discharge air (RT6) when outdoor air is suitable:	Permitted Inputs
TEMP	OFFSET	None Needed	Outdoor air temperature (RT17) is less than return air temperature (RT16) by at least the OFFSET value.	0-40°F
TEMP	OAT STPT	None Needed	Outdoor air temperature (RT17) is less than the OAT STPT value.	41-75°F
Remote	Remote	Energy Management System**	Either of the TEMP modes can be used when a network OAS signal is provided by an energy management or building control system, via BACnet, LonTalk, or L Connection. The network can command OAS, NOT OAS, or AUTO. AUTO returns to local control of OAS, which is the selected TEMP mode.	NA
ENTH	DIFF OFFSET	(Two) C7400	Outdoor air enthalpy* (A7) is less than return air enthalpy (A62) by at least the OFFSET value.	0mA-4mA
ENTH	ODE STPT	C7400	Outdoor air enthalpy (A7) is less than free cooling setpoint.	12-19mA
GLOBAL	GLOBAL	24VAC Input Signal	Global input is energized by (P297-9). This setting is also used for outdoor air damper applications. Global input also brings on the blower. (This mode is NOT used when OAS signal is provided via network connection. GLO is only used when a 24VAC signal is used to energize the P297-9 GLO input.)	NA

*Enthalpy includes effects of both temperature and humidity.

**Energy management systems may require additional field-provided sensors; refer to manufacturer's instructions.

Outdoor Air Damper and Economizer Operation

DIRECT DRIVE DRIVE SYSTEM OPERATION:

Note: Direct drive units feature ECM condenser fans that are staged to match the compressor's capacity.

Modulating Outdoor Air Damper:

Damper minimum positions #1 and 2 are adjusted during unit setup to provide minimum fresh air requirements at the indicated supply fan speeds per ASHRAE 62.1.

- Supply fan is off and the outdoor air damper is closed
- Supply fan is on low speed and the outdoor air damper is at minimum position 1
- Supply fan is on high speed and the outdoor air damper is at minimum position 2

¹Outdoor Air is Suitable

Note: When outdoor air is not suitable during the occupied time period, damper modulates to minimum position. When outdoor air is not suitable during the unoccupied time period, damper modulates closed.

1-Economizer With Outdoor Air Suitable

- Low Cooling Demand -
 - Compressor Off
 - Blower Low
 - Dampers Modulate

High Cooling Demand -

- Compressor Low (036, 048, 060 only)
- Compressor On (024 only)
- Blower High
- Dampers Full Open

Note - Compressor is energized after damper has been at full open for three minutes.

2-No Economizer or Outdoor Air Not Suitable

- Low Demand -
 - Compressor Low
 - Blower Low
 - Damper Minimum Position

High Cooling Demand -

- Compressor High
- Blower High
- Damper Minimum Position

I-Needlepoint Bipolar Ionizer (Optional)

The optional, brush-type ionizer produces positive and negative ions to clean air and reduce airborne contaminants. The ionizer was designed to be low maintenance. The device should be checked semi-annually to confirm the brushes are clean for maximum output. The ionizer is located behind on the blower deck to the left of the blower. See FIGURE 24.

- 1 - On the back side of the unit, remove the screw securing the back of the ionizer bracket. See FIGURE 23. Retain the screw to secure the back side of the ionizer bracket.
- 2 - Remove two screws securing the front side of the ionizer bracket and pull out of unit and clean brushes.
- 3 - Replace ionizer in the reverse order it was removed.

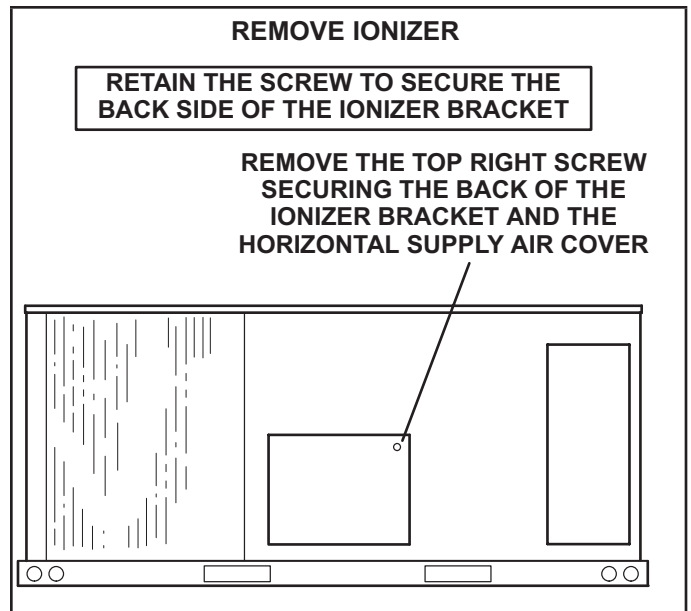

FIGURE 23

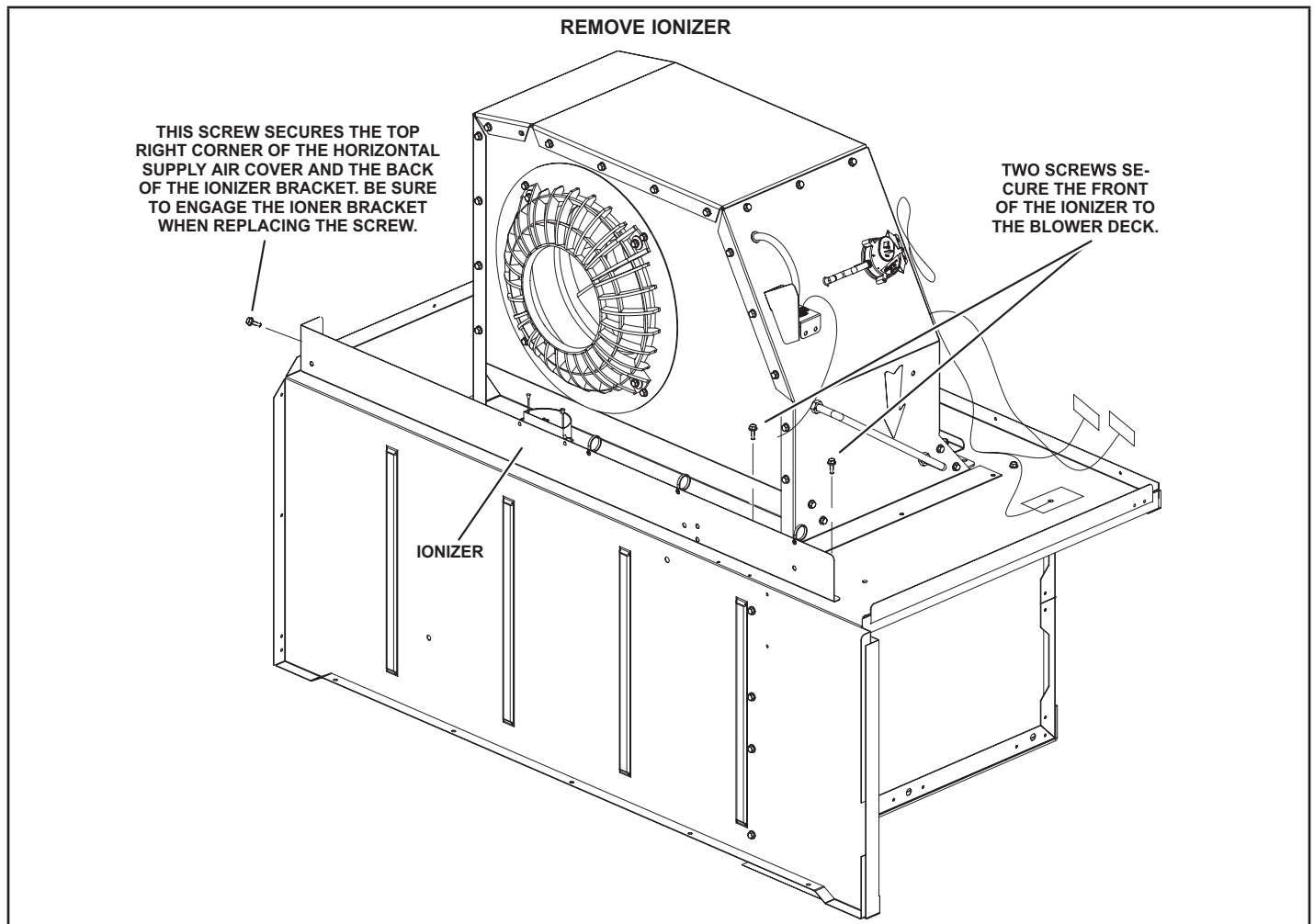

FIGURE 24

VIII-Decommissioning

Before carrying out this procedure, it is essential that the technician is completely familiar with the equipment and all its detail. It is recommended good practice that all refrigerants are recovered safely. Prior to the task being carried out, an oil and refrigerant sample shall be taken in case analysis is required prior to re-use of recovered refrigerant. It is essential that electrical power is available before the task is commenced.

Steps to ensure this are:

- Become familiar with the equipment and its operation,
- Isolate the system electrically,
- Ensure that before attempting the procedure that mechanical handling equipment is available, if required, for handling refrigerant cylinders, and that all personal protective equipment is available and being used correctly while the recovery process is supervised at all times by a competent person and that the recovery equipment and cylinders conform to the appropriate standards.

Additionally, pump down refrigerant system, if possible, and if a vacuum is not possible, make a manifold so that refrigerant can be removed from various parts of the system. Make sure that cylinders are situated on the scales before recovery takes place. Start the recovery machine and operate in accordance with instructions. Do not overfill cylinders (no more than 80 % volume liquid charge). Do not exceed the maximum working pressure of the cylinder, even temporarily. When the cylinders have been filled correctly and the process completed, make sure that the cylinders and the equipment are removed from site promptly and all isolation valves on the equipment are closed off. Recovered refrigerant shall not be charged into another refrigerating system unless it has been cleaned and checked.

Equipment shall be labeled stating that it has been decommissioned and emptied of refrigerant. The label shall be dated and signed. For appliances containing flammable refrigerants, ensure that there are labels on the equipment stating the equipment contains flammable refrigerant.

Under no circumstances shall potential sources of ignition be used in the searching for or detection of refrigerant leaks. A halide torch (or any other detector using a naked flame) shall not be used. Electronic leak detectors may be used to detect refrigerant leaks but, in the case of flammable refrigerants, the sensitivity may not be adequate, or may need re-calibration. (Detection equipment shall be calibrated in a refrigerant-free area).

Ensure that the detector is not a potential source of ignition and is suitable for the refrigerant used. Leak detection equipment shall be set at a percentage of the LFL of the refrigerant and shall be calibrated to the refrigerant employed, and the appropriate percentage of gas (25 % maximum) is confirmed. Leak detection fluids are also suitable for use with most refrigerants but the use of detergents containing chlorine shall be avoided as the chlorine may react with the refrigerant and corrode the copper pipe-work. If a leak is suspected, all naked flames shall be removed/extinguished. If a leakage of refrigerant is found which requires brazing, all of the refrigerant shall be recovered from the system, or isolated (by means of shut off valves) in a part of the system remote from the leak.

When breaking into the refrigerant circuit to make repairs – or for any other purpose – conventional procedures shall be used. However, for flammable refrigerants it is important that best practice be followed, since flammability is a consideration. The following procedure shall be adhered to:

- Safely remove refrigerant following local and national regulations,
- Evacuate the circuit,
- Purge the circuit with inert gas,
- Evacuate,
- Purge with inert gas,
- Open the circuit.

The refrigerant charge shall be recovered into the correct recovery cylinders if venting is not allowed by local and national codes. For appliances containing flammable refrigerants, the system shall be purged with oxygen-free nitrogen to render the appliance safe for flammable refrigerants. This process might need to be repeated several times. Compressed air or oxygen shall not be used for purging refrigerant systems. Refrigerant purging shall be achieved by breaking the vacuum in the system with oxygen-free nitrogen and continuing to fill until the working pressure is achieved, then venting to atmosphere, and finally pulling down to a vacuum. This process shall be repeated until no refrigerant is within the system. When the final oxygen-free nitrogen charge is used, the system shall be vented down to atmospheric pressure to enable work to take place. Ensure that the outlet for the vacuum pump is not close to any potential ignition sources and that ventilation is available.

IX-Wiring Diagrams and Sequence of Operation

LHT036 / 060 G, J Volt

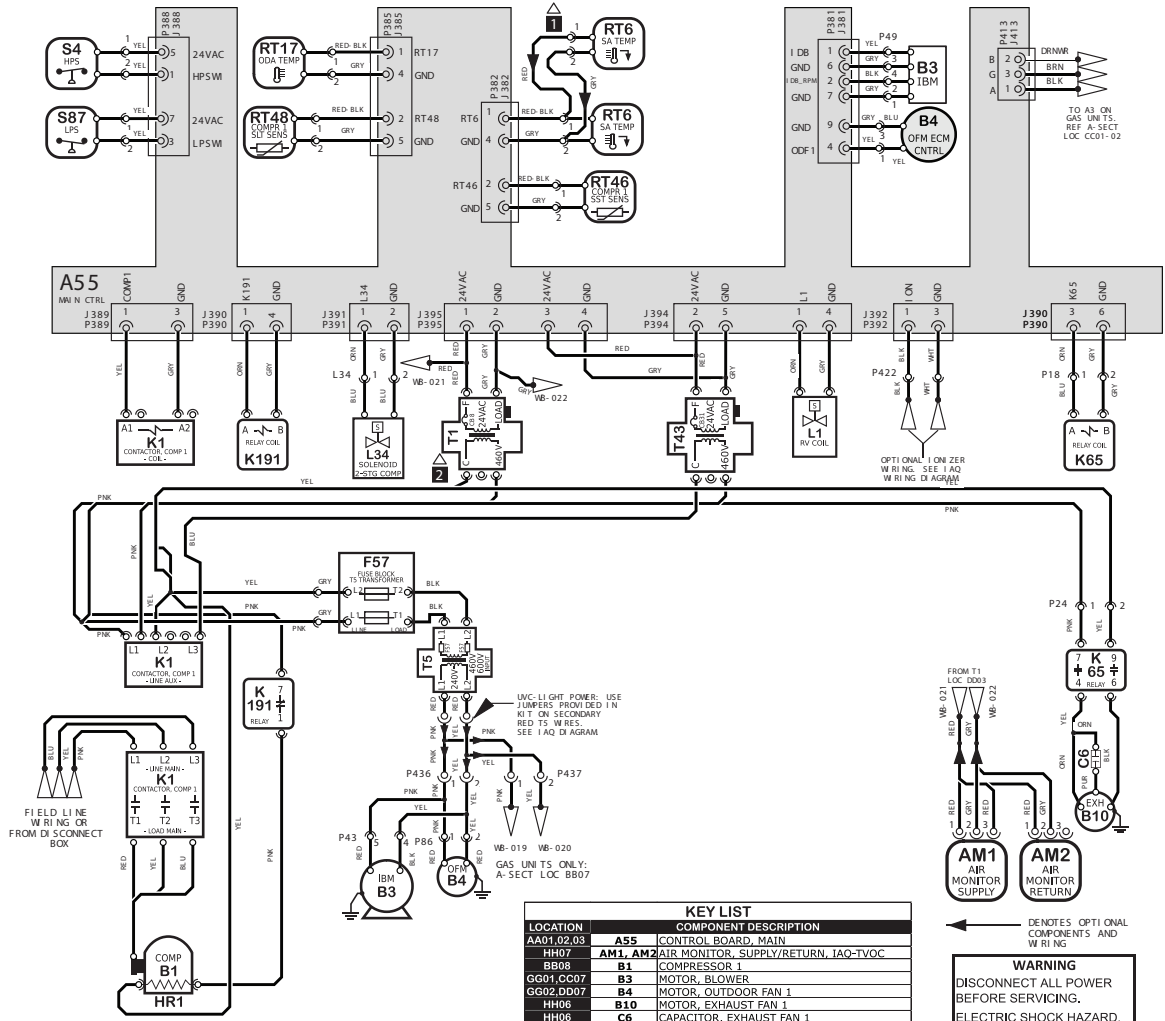

- NOTES**
- RT6 REMOTE MOUNT WIRING
 - MOVE WIRES FROM 240 TO 208 TAP ON TRANSFORMER FOR 208 VOLT APPLICATIONS

LOCATION	COMPONENT DESCRIPTION
AA01,02,03	A55 CONTROL BOARD, MAIN
HH07	AM1, AM2 AIR MONITOR, SUPPLY/RETURN, IAC-TVOC
BB08	B1 COMPRESSOR 1
GG01,CC07	B3 MOTOR, BLOWER
GG02,DD07	B4 MOTOR, OUTDOOR FAN 1
HH06	B10 MOTOR, EXHAUST FAN 1
HH05	C6 CAPACITOR, EXHAUST FAN 1
CC05	F57 FUSE, T5 TRANSFORMER PRIMARY
BB08	HR1 HEATER, COMPRESSOR 1
BB04,05,06	K1 CONTACTOR, COMPRESSOR 1
HH04,05	K65 RELAY, EXHAUST FAN 1
BB04,06	K191 RELAY, CRANKCASE HEATER 1
FF04	L1 VALVE, REVERSING 1
CC04	L34 VALVE, SOLENOID, 2 STG COMPRESSOR
EE01	RT6 SENSOR, A55 DISCHARGE (IMC)
CC01	RT17 SENSOR, OUTSIDE AIR TEMP
EE02	RT46 SENSOR, SAT, SUCT TEMP, COMP 1
CC02	RT48 SENSOR, SAT, LIQUID TEMP, COMP 1
AA01	S4 LIMIT, HI PRESS, SWITCH, COMP 1
AA01	S87 SWITCH, LOW PRESS., COMP 1
DD04	T1 TRANSFORMER, CONTROL
DD05	T5 TRANSFORMER, MOTOR
EE04	T43 TRANSFORMER, REHEAT

Model: LDT, LHT 036H - 060H G, J VOLT
 HEATPUMP - ECM BLOWER WITHOUT HIGHER SCCR
 Voltage: 460V/3~/60Hz (G), 575V/3~/60Hz (J)
 Supersedes: N/A Form No: 538196- 01 Rev: 1

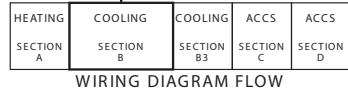

WARNING

DISCONNECT ALL POWER BEFORE SERVICING. ELECTRIC SHOCK HAZARD, CAN CAUSE INJURY OR DEATH. UNIT MUST BE GROUNDED IN ACCORDANCE WITH NATIONAL AND LOCAL CODES.

FOR USE WITH COPPER CONDUCTORS ONLY, REFER TO UNIT RATING PLATE FOR MINIMUM CIRCUIT AMPACITY AND MAXIMUM OVERCURRENT PROTECTION SIZE.

IF ANY WIRE IN THIS APPLIANCE IS REPLACED, IT MUST BE REPLACED WITH WIRE OF LIKE SIZE, RATING AND INSULATION THICKNESS.

LHT036 / 060 G, J Volt

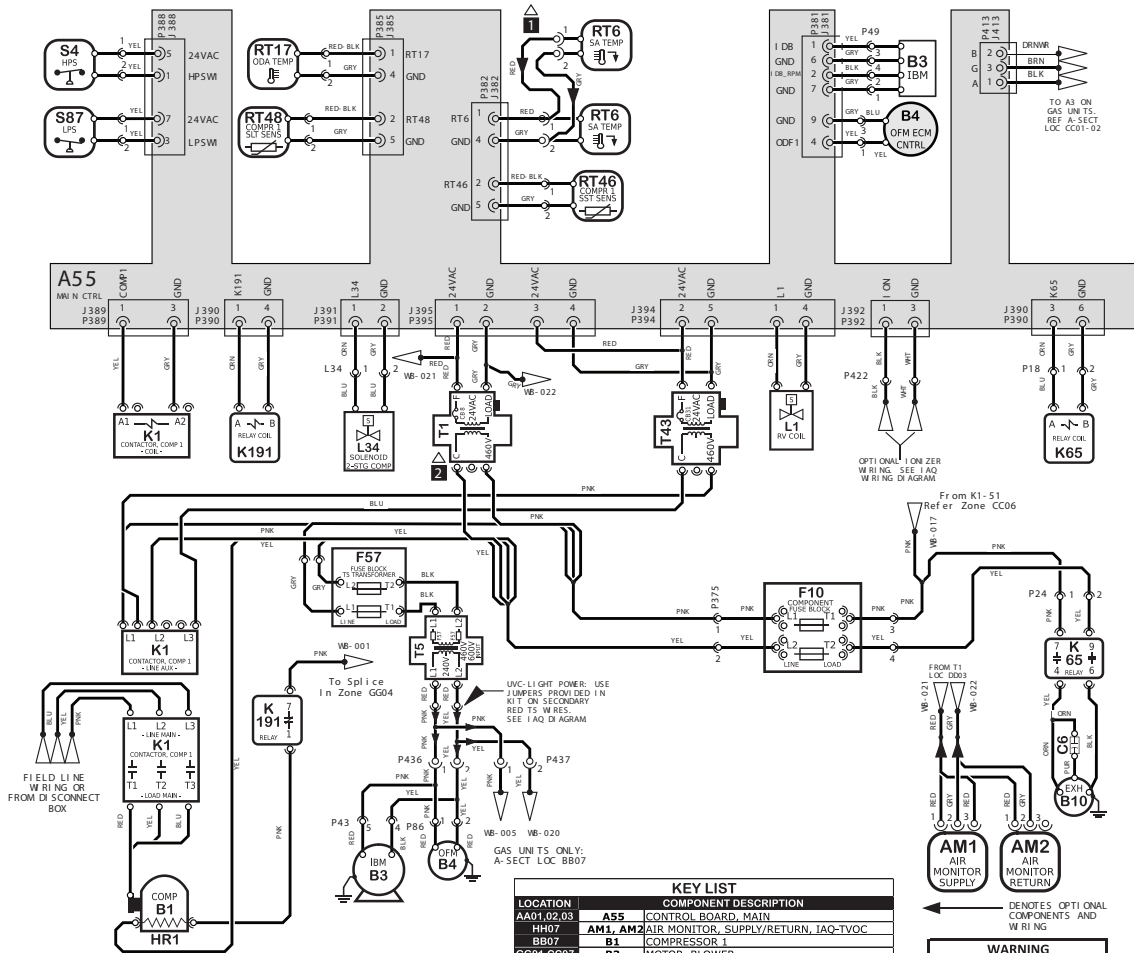

- NOTES**
- 1 RT6 REMOTE MOUNT WIRING
 - 2 MOVE WIRES FROM 240 TO 208 TAP ON TRANSFORMER FOR 208 VOLT APPLICATIONS

KEY LIST

LOCATION	COMPONENT DESCRIPTION
AA01.02.03	A55 CONTROL BOARD, MAIN
HH07	AM1, AM2 AIR MONITOR, SUPPLY/RETURN, IAQ-TVOC
BB07	B1 COMPRESSOR 1
GG01.G007	B3 MOTOR, BLOWER
GG02.DD07	B4 MOTOR, OUTDOOR FAN 1
HH06	B10 MOTOR, EXHAUST FAN 1
HH06	C6 CAPACITOR, EXHAUST FAN 1
FF05	F10 FUSE, COMPONENT
CC05	F57 FUSE, T5 TRANSFORMER PRIMARY
BB07	HR1 HEATER, COMPRESSOR 1
BB04.05.06	K1 CONTACTOR, COMPRESSOR 1
HH04.05	K65 RELAY, EXHAUST FAN 1
BB04.06	K191 RELAY, CRANKCASE HEATER 1
FF04	L1 VALVE, REVERSING 1
CC04	L34 VALVE, SOLENOID, 2 STG COMPRESSOR
EE01	RT6 SENSOR, A55 DISCHARGE (IMC)
CC01	RT17 SENSOR, OUTSIDE AIR TEMP
EE02	RT46 SENSOR, SAT. SUCT TEMP, COMP 1
CC02	RT48 SENSOR, SAT. LIQUID TEMP, COMP 1
AA01	S4 LIMIT, HI PRESS. SWITCH, COMP 1
AA01	S87 SWITCH, LOW PRESS., COMP 1
DD04	T1 TRANSFORMER, CONTROL
DD05	T5 TRANSFORMER, MOTOR
EE04	T43 TRANSFORMER, REHEAT

Model: LDT, LHT 036H - 060H G, J VOLT
 HEATPUMP - ECM BLOWER WITH HIGHER SCCR
 Voltage: 460V/3~/60Hz (G), 575V/3~/60Hz (J)
 Supersedes: N/A Form No: 538197- 01 Rev: 1

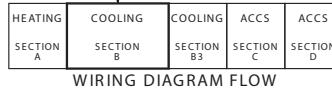

← DENOTES OPTI ONAL COMPONENTS AND W R I N G

WARNING
 DISCONNECT ALL POWER BEFORE SERVICING.
 ELECTRIC SHOCK HAZARD, CAN CAUSE INJURY OR DEATH, UNIT MUST BE GROUNDED IN ACCORDANCE WITH NATIONAL AND LOCAL CODES.
 FOR USE WITH COPPER CONDUCTORS ONLY, REFER TO UNIT RATING PLATE FOR MINIMUM CIRCUIT AMPACITY AND MAXIMUM OVERCURRENT PROTECTION SIZE.
 IF ANY WIRE IN THIS APPLIANCE IS REPLACED, IT MUST BE REPLACED WITH WIRE OF LIKE SIZE, RATING AND INSULATION THICKNESS.

LHT036 / 072 G Volt

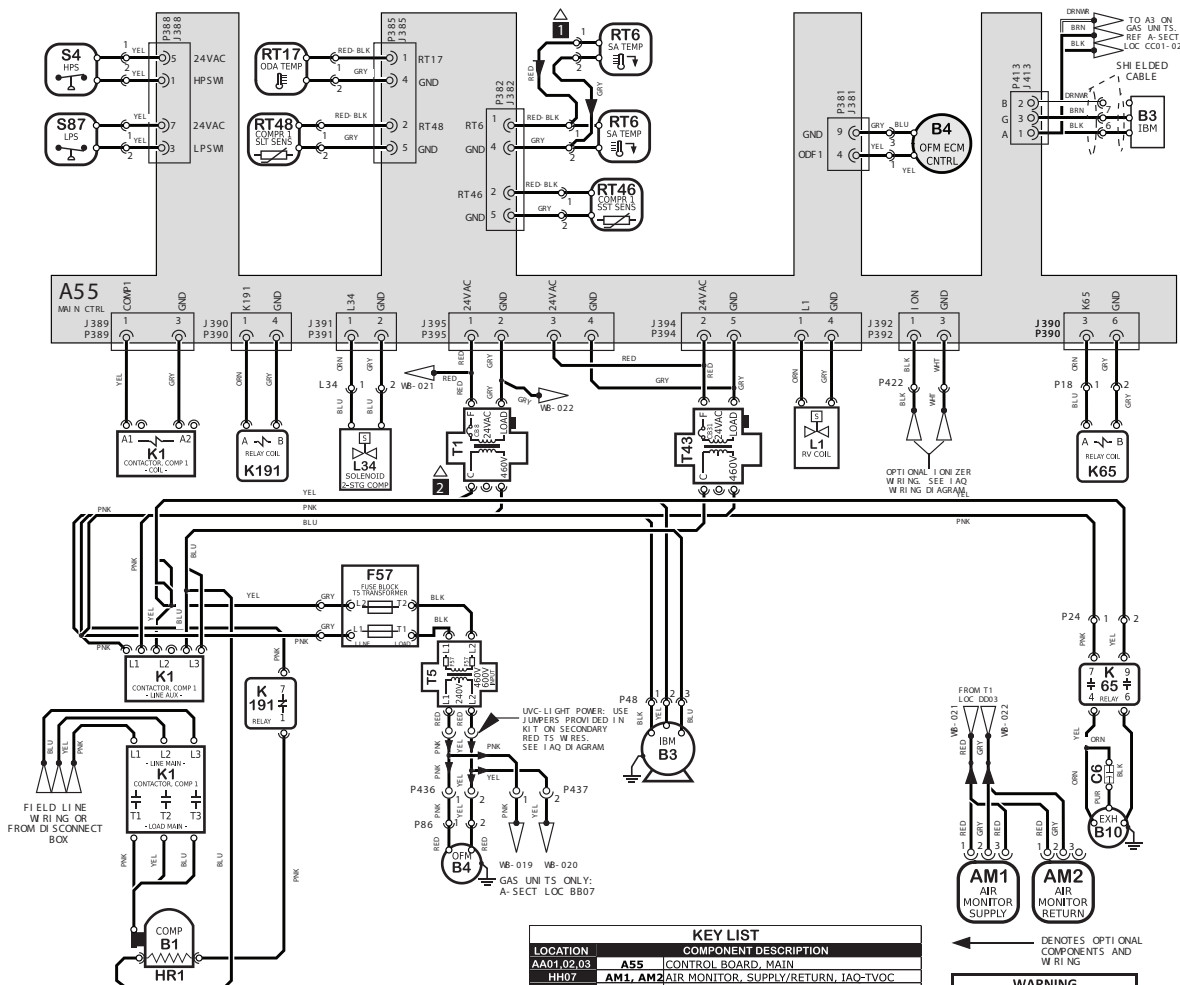

LOCATION	COMPONENT DESCRIPTION
AA01.02.03	A55 CONTROL BOARD, MAIN
HH07	AM1, AM2 AIR MONITOR, SUPPLY/RETURN, IAQ-TVOC
BB07	B1 COMPRESSOR 1
HH04.EE06	B3 MOTOR, BLOWER
GG02.DD07	B4 MOTOR, OUTDOOR FAN 1
HH06	B10 MOTOR, EXHAUST FAN 1
HH06	C6 CAPACITOR, EXHAUST FAN 1
CC05	F57 FUSE, T5 TRANSFORMER PRIMARY
BB07	HR1 HEATER, COMPRESSOR 1
BB04.05.06	K1 CONTACTOR, COMPRESSOR 1
HH04.05	K65 RELAY, EXHAUST FAN 1
BB04.06	K191 RELAY, CRANKCASE HEATER 1
FF04	L1 VALVE, REVERSING 1
CC04	L34 VALVE, SOLENOID, 2 STG COMPRESSOR
EE01	RT6 SENSOR, ASS DISCHARGE (IMC)
CC01	RT17 SENSOR, OUTSIDE AIR TEMP
EE02	RT46 SENSOR, SAT, SUCT TEMP, COMP 1
CC02	RT48 SENSOR, SAT, LIQUID TEMP, COMP 1
AA01	S4 LIMIT, HI PRESS, SWITCH, COMP 1
AA01	S87 SWITCH, LOW PRESS., COMP 1
DD04	T1 TRANSFORMER, CONTROL
DD05	T5 TRANSFORMER, MOTOR
EE04	T43 TRANSFORMER, REHEAT

NOTES	
1	RT6 REMOTE MOUNT WIRING
2	MOVE WIRES FROM 240 TO 208 TAP ON TRANSFORMER FOR 208 VOLT APPLICATIONS

Model: LDT, LHT 036H - 072H G VOLT
 HEATPUMP - EBM BLOWER WITHOUT HIGHER SCCR
 Voltage: 460V/3~/60Hz (G)
 Supersedes: N/A Form No: 538200- 01 Rev: 1

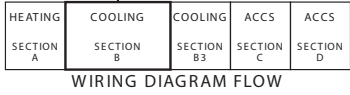

WARNING
 DISCONNECT ALL POWER BEFORE SERVICING.
 ELECTRIC SHOCK HAZARD. CAN CAUSE INJURY OR DEATH. UNIT MUST BE GROUNDED IN ACCORDANCE WITH NATIONAL AND LOCAL CODES.
 FOR USE WITH COPPER CONDUCTORS ONLY. REFER TO UNIT RATING PLATE FOR MINIMUM CIRCUIT AMPACITY AND MAXIMUM OVERCURRENT PROTECTION SIZE.
 IF ANY WIRE IN THIS APPLIANCE IS REPLACED, IT MUST BE REPLACED WITH WIRE OF LIKE SIZE, RATING AND INSULATION THICKNESS.

LHT036 / 072 G Volt

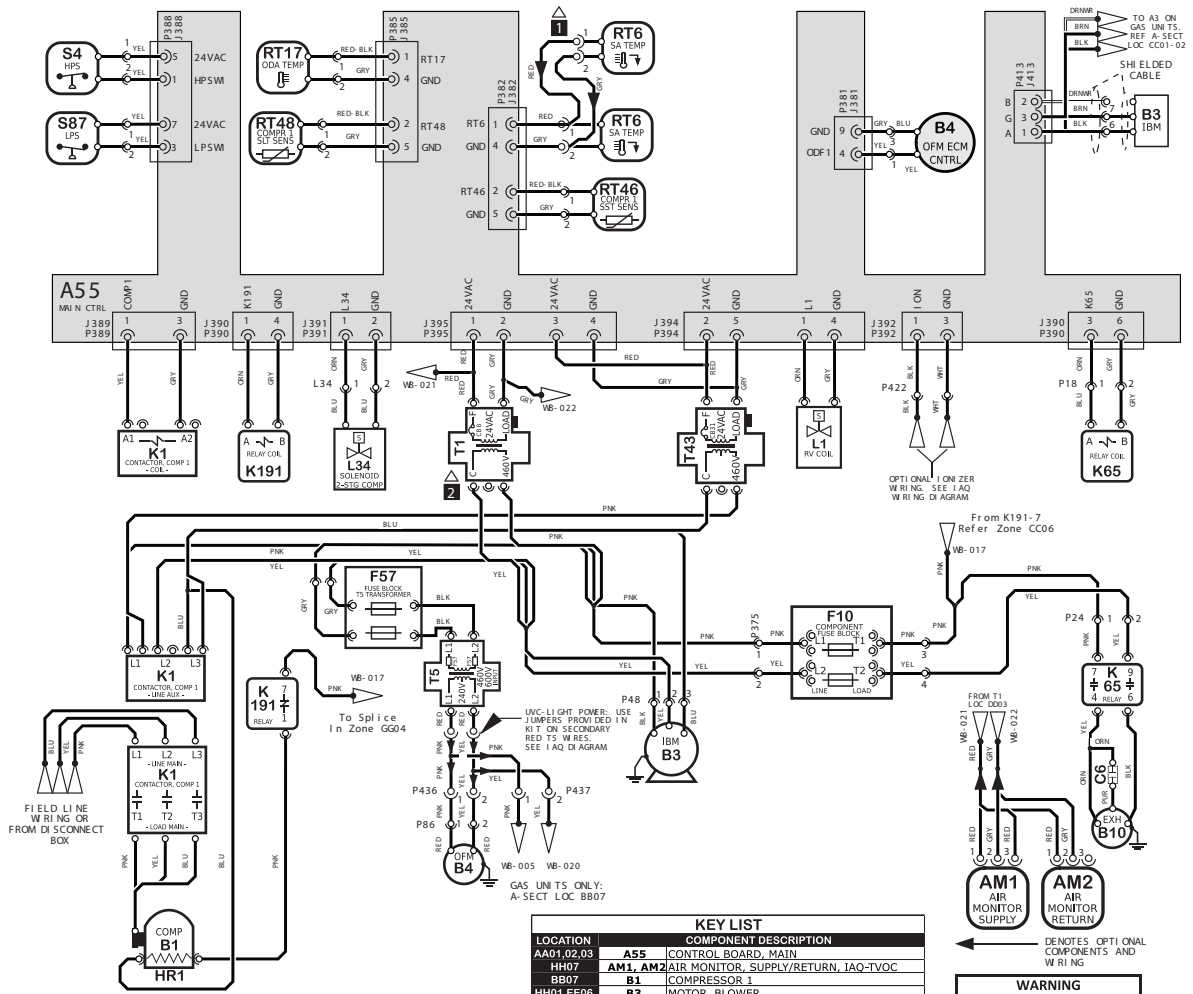

NOTES

1 RT6 REMOTE MOUNT WIRING
 MOVE WIRES FROM 240 TO 208 TAP ON TRANSFORMER FOR 208 VOLT APPLICATIONS

LOCATION	COMPONENT DESCRIPTION
AA01,02,03	A55 CONTROL BOARD, MAIN
HH07	AM1, AM2 AIR MONITOR, SUPPLY/RETURN, IAQ-TVOC
BB07	B1 COMPRESSOR 1
HH01,EE06	B3 MOTOR, BLOWER
GG02,DD07	B4 MOTOR, OUTDOOR FAN 1
HH06	B10 MOTOR, EXHAUST FAN 1
HH06	C6 CAPACITOR, EXHAUST FAN 1
FF05	F10 FUSE, COMPONENT
CC05	F57 FUSE, TS TRANSFORMER PRIMARY
BB07	HR1 HEATER, COMPRESSOR 1
BB04,05,06	K1 CONTACTOR, COMPRESSOR 1
HH04,05	K65 RELAY, EXHAUST FAN 1
BB04,06	K191 RELAY, CRANKCASE HEATER 1
FF04	L1 VALVE, REVERSING 1
CC04	L34 VALVE, SOLENOID, 2 STG COMPRESSOR
EE01	RT6 SENSOR, A55 DISCHARGE (IMC)
CC01	RT17 SENSOR, OUTSIDE AIR TEMP
EE02	RT46 SENSOR, SAT. SUCT. TEMP, COMP 1
CC02	RT48 SENSOR, SAT. LIQUID TEMP, COMP 1
AA01	S4 LIMIT, HI PRESS, SWITCH, COMP 1
AA01	S87 SWITCH, LOW PRESS., COMP 1
DD04	T1 TRANSFORMER, CONTROL
DD05	T5 TRANSFORMER, MOTOR
EE04	T43 TRANSFORMER, REHEAT

Model: LDT, LHT 036H - 072H G VOLT
 HEATPUMP - EBM BLOWER WITH HIGHER SCCR
 460V/3~/60Hz (G)

Voltage: 460V/3~/60Hz (G)

Supersedes: N/A Form No: 538201- 01 Rev: 1

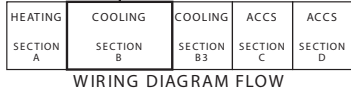

WARNING

DISCONNECT ALL POWER BEFORE SERVICING. ELECTRIC SHOCK HAZARD, CAN CAUSE INJURY OR DEATH. UNIT MUST BE GROUNDED IN ACCORDANCE WITH NATIONAL AND LOCAL CODES.

FOR USE WITH COPPER CONDUCTORS ONLY. REFER TO UNIT RATING PLATE FOR MINIMUM CIRCUIT AMPACITY AND MAXIMUM OVERCURRENT PROTECTION SIZE.

IF ANY WIRE IN THIS APPLIANCE IS REPLACED, IT MUST BE REPLACED WITH WIRE OF LIKE SIZE, RATING AND INSULATION THICKNESS.

LHT036 / 072 J Volt

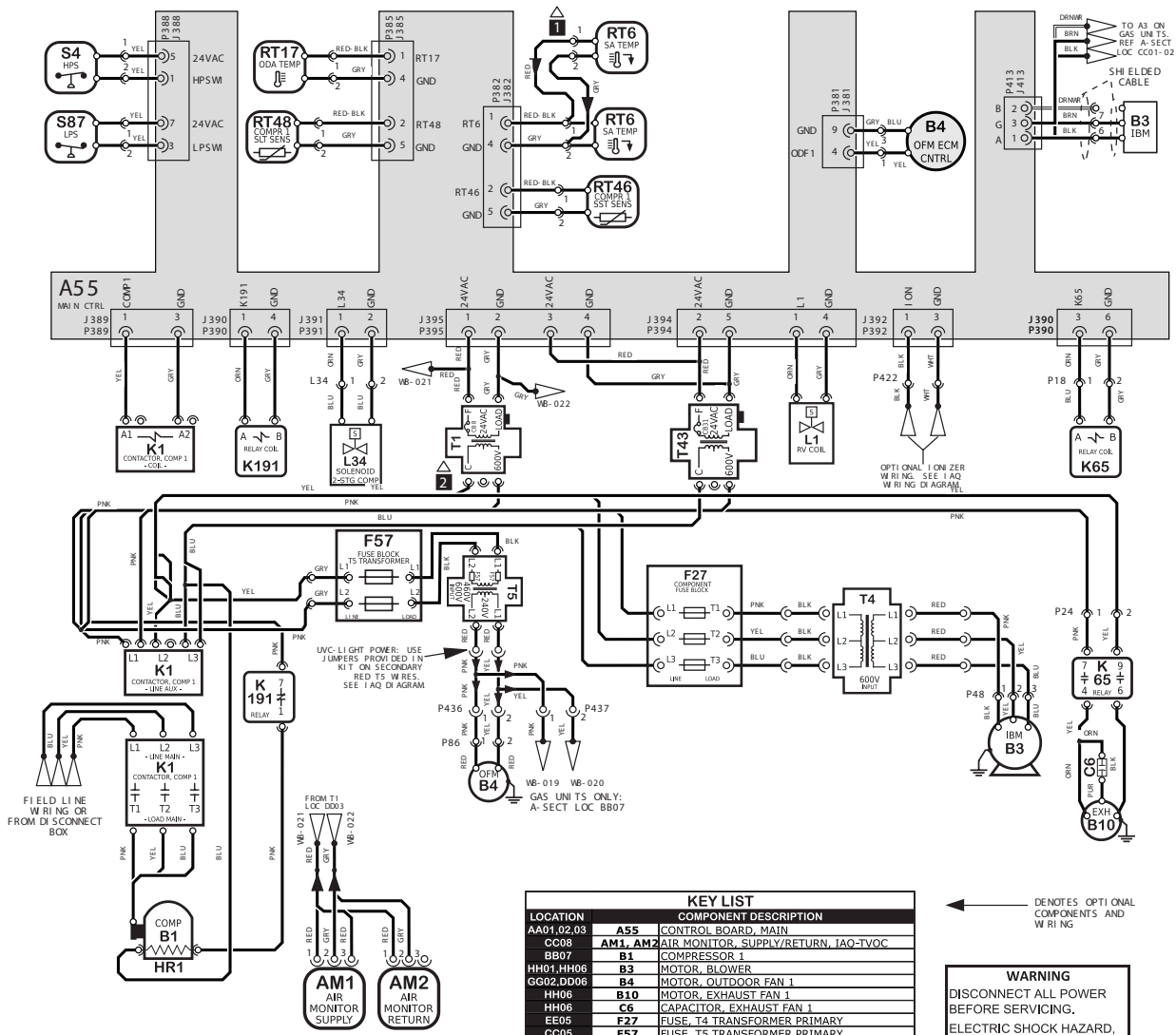

NOTES	
1	RT6 REMOTE MOUNT WIRING
2	MOVE WIRES FROM 240 TO 208 TAP ON TRANSFORMER FOR 208 VOLT APPLICATIONS

KEY LIST		
LOCATION	COMPONENT	DESCRIPTION
AA01,02,03	A55	CONTROL BOARD, MAIN
CC08	AM1, AM2	AIR MONITOR, SUPPLY/RETURN, IAQ-TVOC
BB07	B1	COMPRESSOR 1
HH01,HH06	B3	MOTOR, BLOWER
GG02,DD06	B4	MOTOR, OUTDOOR FAN 1
HH06	B10	MOTOR, EXHAUST FAN 1
EE05	C6	CAPACITOR, EXHAUST FAN 1
CC05	F27	FUSE, T4 TRANSFORMER PRIMARY
BB07	F57	FUSE, T5 TRANSFORMER PRIMARY
BB07	HR1	HEATER, COMPRESSOR 1
BB04,05,06	K1	CONTACTOR, COMPRESSOR 1
HH04,05	K65	RELAY, EXHAUST FAN 1
BB04,06	K191	RELAY, CRANKCASE HEATER 1
FF04	L1	VALVE, REVERSING 1
CC04	L34	VALVE, SOLENOID, 2 STG COMPRESSOR
EE01	RT16	SENSOR, A55 DISCHARGE (IMC)
CC01	RT17	SENSOR, OUTSIDE AIR TEMP
EE02	RT46	SENSOR, SAT. SUCT. TEMP., COMP 1
CC02	RT48	SENSOR, SAT. LIQUID TEMP., COMP 1
AA01	S4	LIMIT, HI PRESS., SWITCH, COMP 1
AA01	S87	SWITCH, LOW PRESS., COMP 1
DD04	T1	TRANSFORMER, CONTROL
GG05	T4	TRANSFORMER, BLOWER
DD05	T5	TRANSFORMER, OUTDOOR FAN 1
EE04	T43	TRANSFORMER, REHEAT

← DENOTES OPTI ONAL COMPONENTS AND W R I N G

WARNING
DISCONNECT ALL POWER BEFORE SERVICING. ELECTRIC SHOCK HAZARD, CAN CAUSE INJURY OR DEATH. UNIT MUST BE GROUNDED IN ACCORDANCE WITH NATIONAL AND LOCAL CODES.
FOR USE WITH COPPER CONDUCTORS ONLY, REFER TO UNIT RATING PLATE FOR MINIMUM CIRCUIT AMPACITY AND MAXIMUM OVERCURRENT PROTECTION SIZE.
IF ANY WIRE IN THIS APPLIANCE IS REPLACED, IT MUST BE REPLACED WITH WIRE OF LIKE SIZE, RATING AND INSULATION THICKNESS.

Model: LDT, LHT 036H - 072H J VOLT
HEATPUMP - EBM BLOWER WITHOUT HIGHER SCCR
Voltage: 575V/3~/60Hz (J)
Supersedes: N/A Form No: 538202-01 Rev: 1

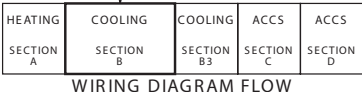

LHT036 / 072 J Volt

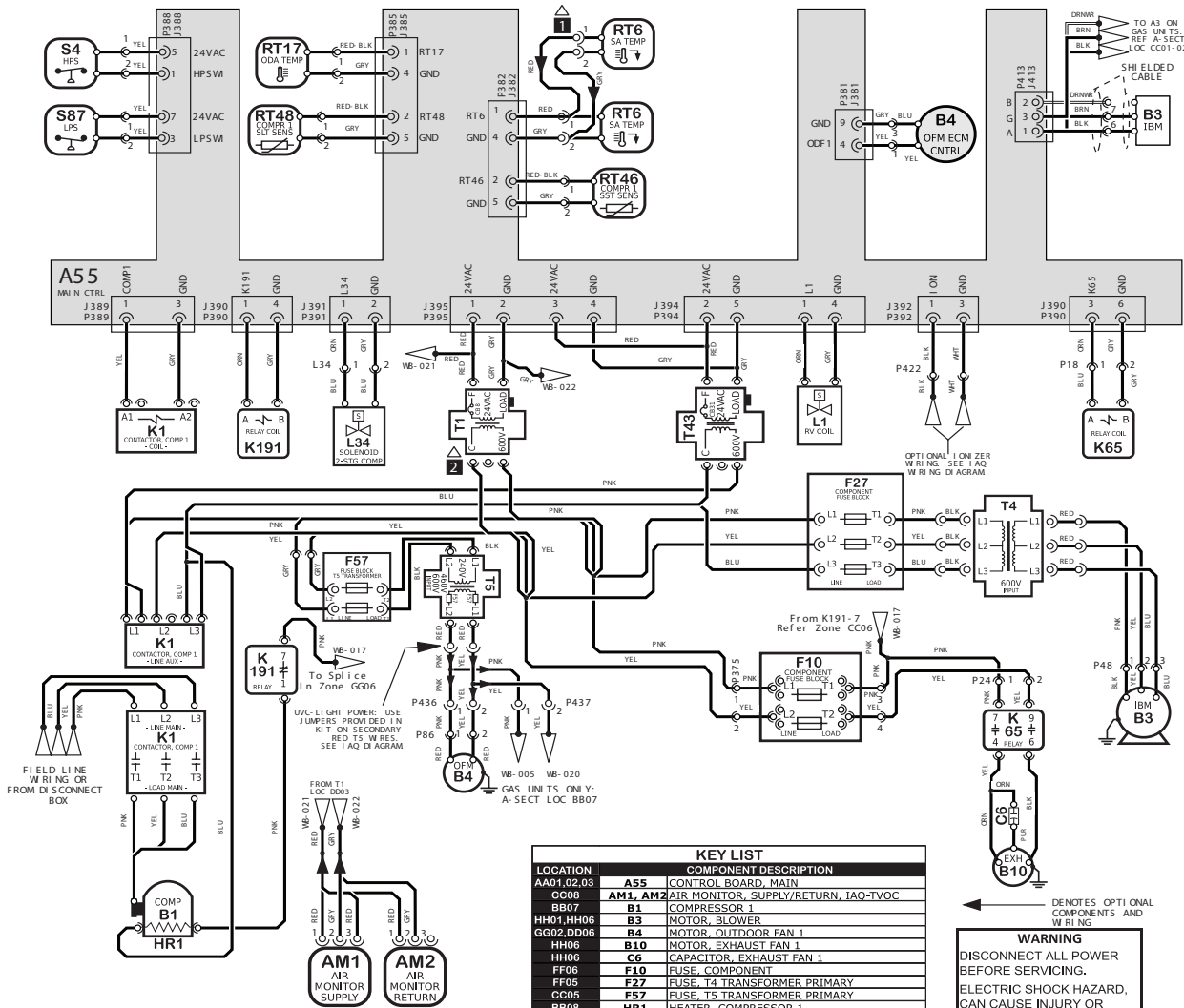

LOCATION	COMPONENT DESCRIPTION
AA01,02,03	A55 CONTROL BOARD, MAIN
CC05	AM1, AM2 AIR MONITOR, SUPPLY/RETURN, IAQ-TVOC
BB07	B1 COMPRESSOR 1
HH04,HH06	B3 MOTOR, BLOWER
GG02,DD06	B4 MOTOR, OUTDOOR FAN 1
HH06	B10 MOTOR, EXHAUST FAN 1
HH05	C6 CAPACITOR, EXHAUST FAN 1
FF05	F10 FUSE, COMPONENT
FF05	F27 FUSE, T4 TRANSFORMER PRIMARY
CC05	F57 FUSE, T5 TRANSFORMER PRIMARY
BB08	HR1 HEATER, COMPRESSOR 1
BB04,05,06	K1 CONTACTOR, COMPRESSOR 1
HH04,06	K65 RELAY, EXHAUST FAN 1
BB04,06	K191 RELAY, CRANKCASE HEATER 1
FF04	L1 VALVE, REVERSING 1
CC04	L34 VALVE, SOLENOID, 2 STG COMPRESSOR
EE01	RT6 SENSOR, A55 DISCHARGE (IMC)
CC01	RT17 SENSOR, OUTSIDE AIR TEMP
EE02	RT46 SENSOR, SAT. SUCT. TEMP, COMP 1
CC02	RT48 SENSOR, SAT. LIQUID TEMP, COMP 1
AA01	S4 LIMIT, HI PRESS. SWITCH, COMP 1
AA01	S87 SWITCH, LOW PRESS., COMP 1
DD04	T1 TRANSFORMER, CONTROL
HH05	T4 TRANSFORMER, BLOWER
DD05	T5 TRANSFORMER, OUTDOOR FAN 1
EE04	T43 TRANSFORMER, REHEAT

NOTES	
1	RT6 REMOTE MOUNT WIRING
2	MOVE WIRES FROM 240 TO 208 TAP ON TRANSFORMER FOR 208 VOLT APPLICATIONS

Model: LDT, LHT 036H - 072H J VOLT
 HEATPUMP - EBM BLOWER WITH HIGHER SCCR
 Voltage: 575V/3~/60Hz (J)
 Supersedes: N/A Form No: 538203-01 Rev: 2

SECTION A	SECTION B	SECTION B3	SECTION C	SECTION D
HEATING	COOLING	COOLING	ACCS	ACCS

WIRING DIAGRAM FLOW

WARNING
 DISCONNECT ALL POWER BEFORE SERVICING.
 ELECTRIC SHOCK HAZARD, CAN CAUSE INJURY OR DEATH. UNIT MUST BE GROUNDED IN ACCORDANCE WITH NATIONAL AND LOCAL CODES.
 FOR USE WITH COPPER CONDUCTORS ONLY. REFER TO UNIT RATING PLATE FOR MINIMUM CIRCUIT AMPACITY AND MAXIMUM OVERCURRENT PROTECTION SIZE.
 IF ANY WIRE IN THIS APPLIANCE IS REPLACED, IT MUST BE REPLACED WITH WIRE OF LIKE SIZE, RATING AND INSULATION THICKNESS.

LHT036 / 060 P, Y Volt

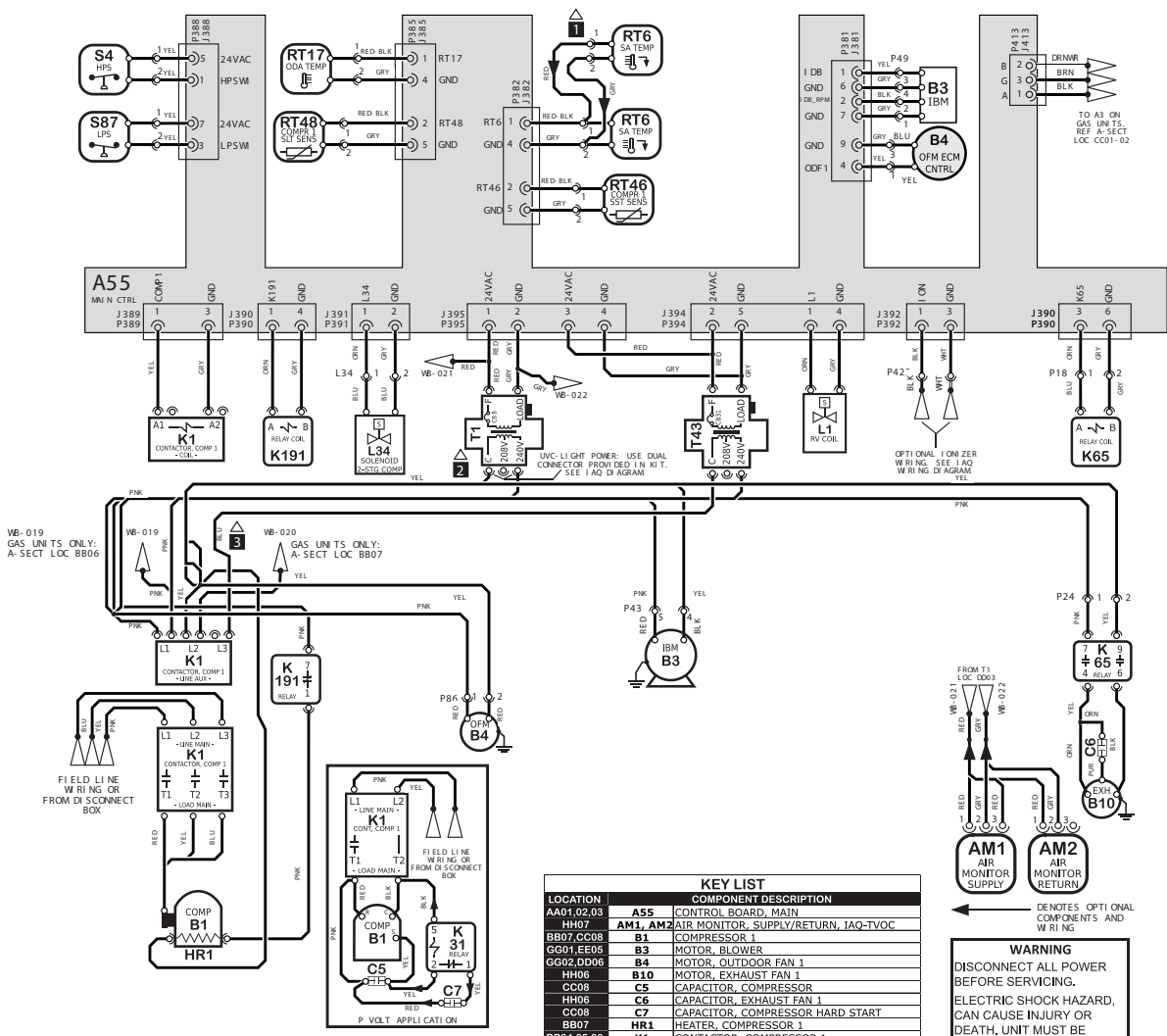

WB-019
GAS UNITS ONLY;
A-SECT LOC BB06

WB-020
GAS UNITS ONLY;
A-SECT LOC BB07

LOCATION	COMPONENT DESCRIPTION
AA01.02.03	A55 CONTROL BOARD, MAIN
HH07	AM1, AM2 AIR MONITOR, SUPPLY/RETURN, IAQ-TVOC
BB07, CC08	B1 COMPRESSOR 1
GG01, EE05	B3 MOTOR, BLOWER
GG02, DD06	B4 MOTOR, OUTDOOR FAN 1
HH06	B10 MOTOR, EXHAUST FAN 1
CC08	C5 CAPACITOR, COMPRESSOR
HH06	C6 CAPACITOR, EXHAUST FAN 1
CC08	C7 CAPACITOR, COMPRESSOR HARD START
BB07	HR1 HEATER, COMPRESSOR 1
BB04.05.06	K1 CONTACTOR, COMPRESSOR 1
DD08	K31 RELAY, HARD START KIT
HH04.05	K65 RELAY, EXHAUST FAN 1
BB04.05	K191 RELAY, CRANKCASE HEATER 1
FF04	L1 VALVE, REVERSING 1
CC04	L34 VALVE, SOLENOID, 2 STG COMPRESSOR
EE01	RT6 SENSOR, A55 DISCHARGE (IMC)
CC01	RT17 SENSOR, OUTSIDE AIR TEMP
EE02	RT46 SENSOR, SAT. SUCT. TEMP, COMP 1
CC02	RT48 SENSOR, SAT. LIQUID TEMP, COMP 1
AA01	S4 LIMIT, HI PRESS. SWITCH, COMP 1
AA01	S87 SWITCH, LOW PRESS., COMP 1
DD04	T1 TRANSFORMER, CONTROL
EE04	T43 TRANSFORMER, REHEAT

- NOTES**
- RT6 REMOTE MOUNT WIRING
 - MOVE WIRES FROM 240 TO 208 TAP ON TRANSFORMER FOR 208 VOLT APPLICATIONS
 - P-VOLT UNITS - CONNECT T43-C TO K1-L2

Model: LDT, LHT 024H - 060H P, Y VOLT
HEATPUMP - ECM BLOWER WITHOUT HIGHER SCCR
Voltage: 208-240V/1~60Hz(P), 208-240V/3~60Hz(Y)
Supersedes: N/A Form No: 538194-01 Rev: 1

HEATING SECTION A	COOLING SECTION B	COOLING SECTION C	ACCS SECTION D	ACCS SECTION E

WIRING DIAGRAM FLOW

WARNING
DISCONNECT ALL POWER BEFORE SERVICING.
ELECTRIC SHOCK HAZARD, CAN CAUSE INJURY OR DEATH. UNIT MUST BE GROUNDED IN ACCORDANCE WITH NATIONAL AND LOCAL CODES.
FOR USE WITH COPPER CONDUCTORS ONLY, REFER TO UNIT RATING PLATE FOR MINIMUM CIRCUIT AMPACITY AND MAXIMUM OVERCURRENT PROTECTION SIZE.
IF ANY WIRE IN THIS APPLIANCE IS REPLACED, IT MUST BE REPLACED WITH WIRE OF LIKE SIZE, RATING AND INSULATION THICKNESS.

LHT036 / 060 P, Y Volt

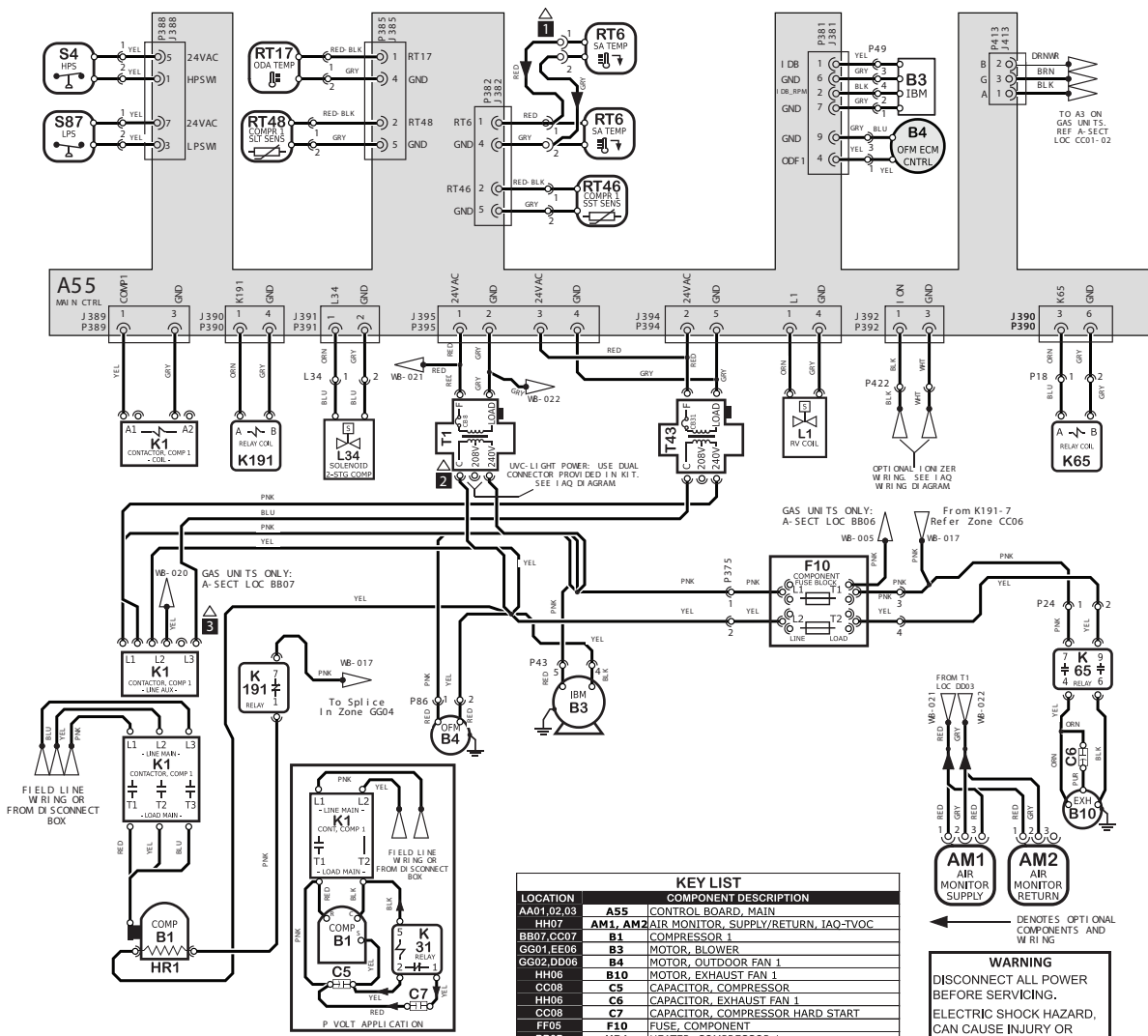

NOTES	
1	RT6 REMOTE MOUNT WIRING
2	MOVE WIRES FROM 240 TO 208 TAP ON TRANSFORMER FOR 208 VOLT APPLICATIONS
3	P-VOLT UNITS - CONNECT T43-C TO K1-L2

KEY LIST	
LOCATION	COMPONENT DESCRIPTION
AA01,02,03	A55 CONTROL BOARD, MAIN
HH07	AM1, AM2 AIR MONITOR, SUPPLY/RETURN, IAQ-TVOC
BB07,CC07	B1 COMPRESSOR 1
GG01,EE08	B3 MOTOR, BLOWER
GG02,DD06	B4 MOTOR, OUTDOOR FAN 1
HH06	B10 MOTOR, EXHAUST FAN 1
CC08	C5 CAPACITOR, COMPRESSOR
HH06	C6 CAPACITOR, EXHAUST FAN 1
CC08	C7 CAPACITOR, COMPRESSOR HARD START
FF05	F10 FUSE, COMPONENT
BB07	HR1 HEATER, COMPRESSOR 1
BB04,05,06	K1 CONTACTOR, COMPRESSOR 1
DD08	K31 RELAY, HARD START KIT
HH04,05	K65 RELAY, EXHAUST FAN 1
BB04,06	K191 RELAY, CRANKCASE HEATER 1
FF04	L1 VALVE, REVERSING 1
CC04	L34 VALVE, SOLENOID, 2 STG COMPRESSOR
EE01	RT6 SENSOR, AS5 DISCHARGE (IMC)
CC01	RT17 SENSOR, OUTSIDE AIR TEMP
EE02	RT46 SENSOR, SAT. SUCT TEMP, COMP 1
CC02	RT48 SENSOR, SAT. LIQUID TEMP, COMP 1
AA01	S4 LIMIT, HI PRESS, SWITCH, COMP 1
AA01	S87 SWITCH, LOW PRESS, COMP 1
DD04	T1 TRANSFORMER, CONTROL
EE04	T43 TRANSFORMER, REHEAT

Model: LDT, LHT 024H - 060H P, Y VOLT
 HEATPUMP - ECM BLOWER WITH HIGHER SCCR
 Voltage: 208-240V/1~/60Hz(P), 208-240V/3~/60Hz(Y)
 Supersedes: N/A Form No: 538195- 01 Rev: 1

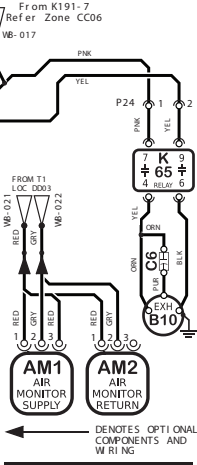
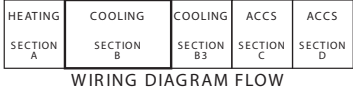

WARNING
 DISCONNECT ALL POWER BEFORE SERVICING.
 ELECTRIC SHOCK HAZARD, CAN CAUSE INJURY OR DEATH. UNIT MUST BE GROUNDED IN ACCORDANCE WITH NATIONAL AND LOCAL CODES.
 FOR USE WITH COPPER CONDUCTORS ONLY. REFER TO UNIT RATING PLATE FOR MINIMUM CIRCUIT AMPACITY AND MAXIMUM OVERCURRENT PROTECTION SIZE.
 IF ANY WIRE IN THIS APPLIANCE IS REPLACED, IT MUST BE REPLACED WITH WIRE OF LIKE SIZE, RATING AND INSULATION THICKNESS.

LHT036 / 072 Y Volt

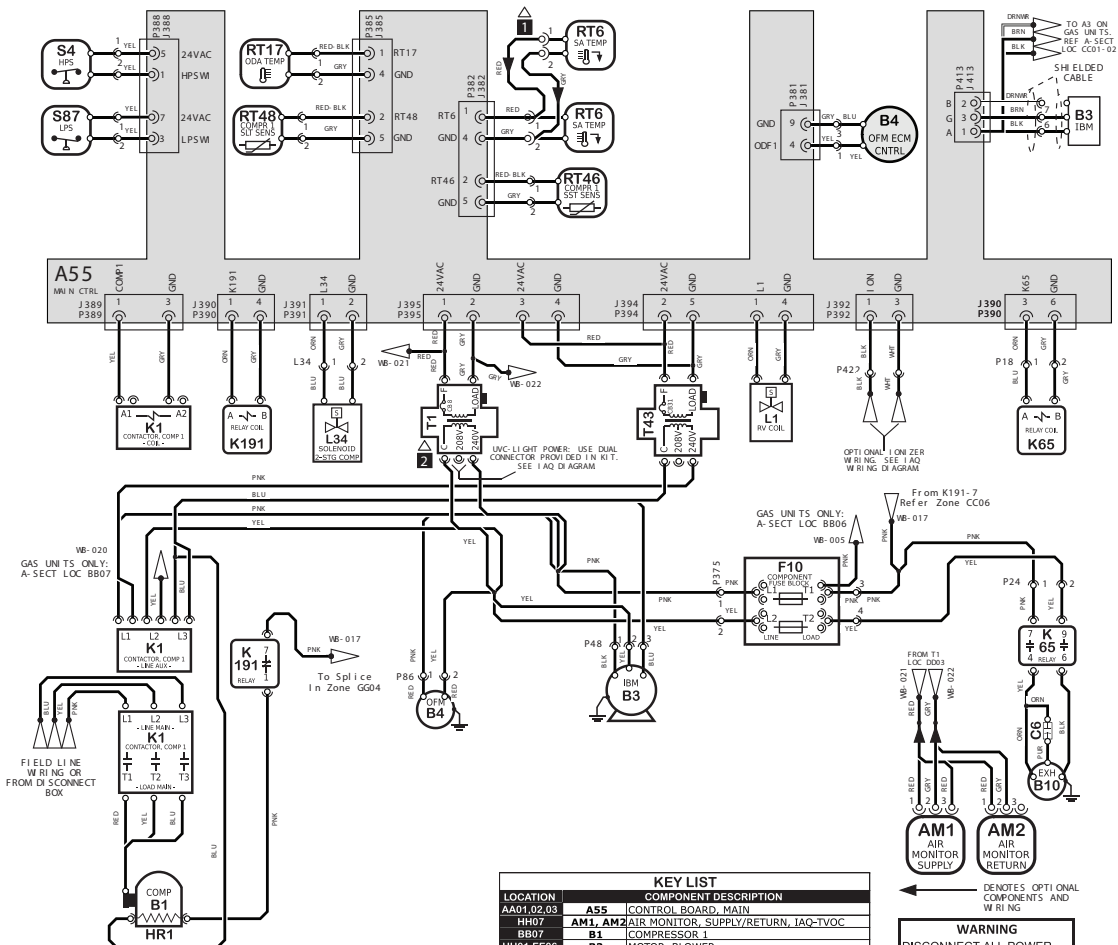

NOTES	
1	RT6 REMOTE MOUNT WIRING
2	MOVE WIRES FROM 240 TO 208 TAP ON TRANSFORMER FOR 208 VOLT APPLICATIONS

KEY LIST	
LOCATION	COMPONENT DESCRIPTION
AA01,02,03	A55 CONTROL BOARD, MAIN
HH07	AM1, AM2 AIR MONITOR, SUPPLY/RETURN, IAQ-TVOC
BB07	B1 COMPRESSOR 1
HH04,EE06	B3 MOTOR, BLOWER
GG02,DD06	B4 MOTOR, OUTDOOR FAN 1
HH06	B10 MOTOR, EXHAUST FAN 1
HH06	C6 CAPACITOR, EXHAUST FAN 1
FF05	F10 FUSE, COMPONENT
BB07	HR1 HEATER, COMPRESSOR 1
BB04,05,06	K1 CONTACTOR, COMPRESSOR 1
HH04,05	K65 RELAY, EXHAUST FAN 1
BB04,06	K191 RELAY, CRANKCASE HEATER 1
FF04	L1 VALVE, REVERSING 1
CC04	L34 VALVE, SOLENOID, 2 STG COMPRESSOR
EE01	RT6 SENSOR, ASS DISCHARGE (IMC)
CC01	RT17 SENSOR, OUTSIDE AIR TEMP
EE02	RT46 SENSOR, SAT. SUCT TEMP, COMP 1
CC02	RT48 SENSOR, SAT. LIQUID TEMP, COMP 1
AA01	S4 LIMIT, HI PRESS, SWITCH, COMP 1
AA01	S87 SWITCH, LOW PRESS., COMP 1
DD04	T1 TRANSFORMER, CONTROL
EE04	T43 TRANSFORMER, REHEAT

Model: LDT, LHT 036H - 072H Y VOLT
 HEATPUMP - EBM BLOWER WITH HIGHER SCCR
 Voltage: 208-240V/3~/60Hz (Y)
 Supersedes: N/A Form No: 538199- 01 Rev: 1

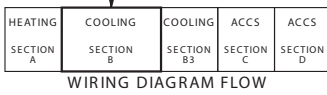

WARNING
 DISCONNECT ALL POWER BEFORE SERVICING.
 ELECTRIC SHOCK HAZARD, CAN CAUSE INJURY OR DEATH, UNIT MUST BE GROUNDED IN ACCORDANCE WITH NATIONAL AND LOCAL CODES.
 FOR USE WITH COPPER CONDUCTORS ONLY. REFER TO UNIT RATING PLATE FOR MINIMUM CIRCUIT AMPACITY AND MAXIMUM OVERCURRENT PROTECTION SIZE.
 IF ANY WIRE IN THIS APPLIANCE IS REPLACED, IT MUST BE REPLACED WITH WIRE OF LIKE SIZE, RATING AND INSULATION THICKNESS.

Cooling Sequence of Operation

Power:

- 1- Line voltage energizes transformer T1. T1 provides 24VAC power to the A55 Unit Controller. A55 provides 24VAC to the unit cooling, heating and blower controls.
- 2- Line voltage provides voltage to compressor crankcase heater relay K191-1 N.C. contacts, compressor contactor K1, blower motor B3, and outdoor fan motor B4 (on G volt units line voltage is supplied to two fuses F27, transformer T4, blower motor B3, and outdoor fan motor B4).

Blower Operation:

- 3- The A55 Unit Controller receives a demand from thermostat terminal G. A55 energizes blower motor B3 via programmed motor settings. Motor settings are field-adjustable.

First Stage Cooling

- 4- A55 Unit Controller receives Y1 and G cooling demand.
- 5- After A55 proves n.c. low pressure switch S87, n.c. SST, and n.c. high pressure switch S4, reversing valve (L1), compressor contactor K1 and Blower B3 are energized.
- 6- N.O. contacts K1-1 close energizing the compressor B1.
- 7- SLT prove below 62°F. A55 energized outdoor fan motor B4 to modulate. If above 65°F, outdoor fan motor B4 will be set to low speed.

Second Stage Cooling

- 8- A55 received a Y2 and G cooling demand and energizes blower B3 on high speed.
- 9- A55 Energizes compressor solenoid L34, switching compressor to high speed.

Power Exhaust Fan Operation

- 10- A55 receives a position feedback signal from the economizer damper motor and energizes exhaust fan relay K65 with 24VAC at 50% outside air damper open (adjustable).
- 11- N.O. contact K65-1 & 2 close, energizing exhaust fan motor B10.

E1EH-7.5, 15, 22.5, 30kW G, J Volt

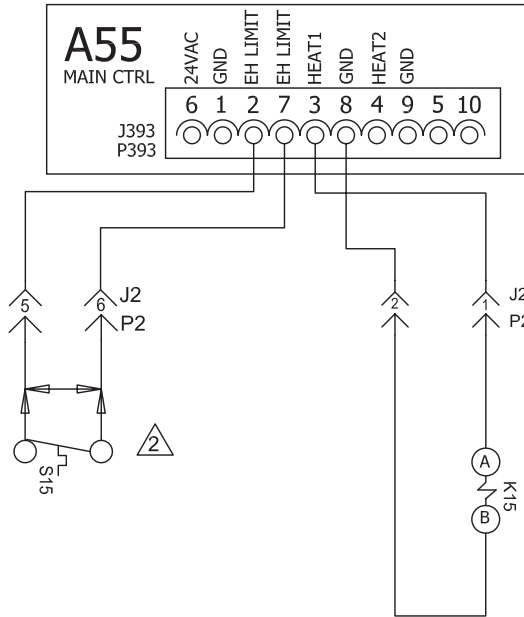

DESCRIPTION	
KEY	DESCRIPTION
A55	PANEL, MAIN
F3	FUSE, ELECTRIC HEAT
F4	FUSE, UNIT
F61	FUSE, UNIT - SCCR
HE-1	ELEMENT, ELECTRIC HEAT 1
J2	JACK, ELECTRIC HEAT
K15,-1	CONTACTOR, ELECTRIC HEAT 1
P2	PLUG, ELECTRIC HEAT
P393	PLUG, ELECTRIC HEAT CONTROL
S15	SWITCH, LIMIT PRIMARY ELECTRIC HEAT
S20	SWITCH, LIMIT SECONDARY ELECTRIC HEAT 1
S157	SWITCH, LIMIT SECONDARY ELECTRIC HEAT 2
TB2	TERMINAL STRIP, UNIT

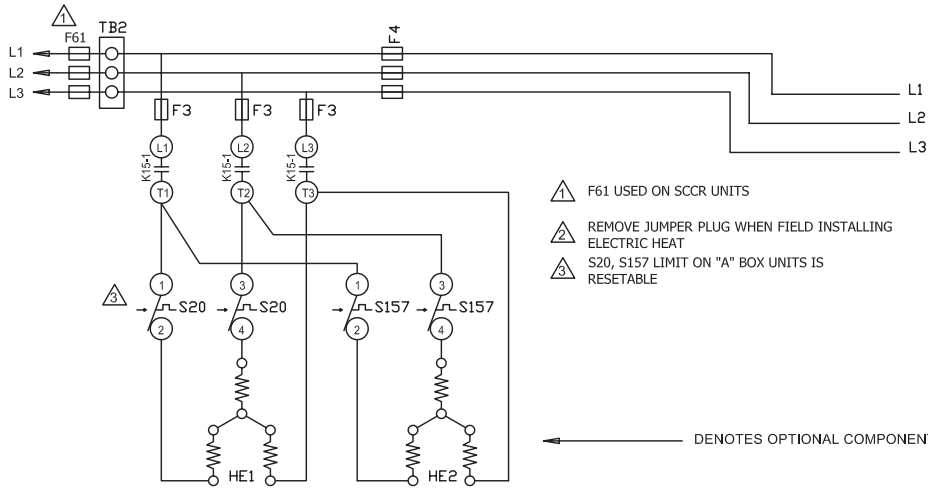

- ⚠ F61 USED ON SCCR UNITS
- ⚠ REMOVE JUMPER PLUG WHEN FIELD INSTALLING ELECTRIC HEAT
- ⚠ S20, S157 LIMIT ON "A" BOX UNITS IS RESETTABLE

← DENOTES OPTIONAL COMPONENTS

		KW	HE1	HE2	
072	060	036 - 048	7.5	7.5	
			15	15	
			22.5	15	7.5
			30	15	15

2020/10	WIRING DIAGRAM	10/20
538117-01		
HEATING		
ELECTRIC HEAT E1EH - 7.5, 15, 22.5, 30 - G, J		
SECTION A		REV 0
Supersedes	New Form No. 538117-01	
© 2010	Lennox Commercial	

E1EH- 7.5, 15, 22.5, 30kW -Y Volt

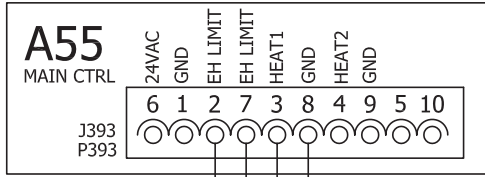

DESCRIPTION	
KEY	DESCRIPTION
A55	PANEL, MAIN
F3	FUSE, ELECTRIC HEAT
F4	FUSE, UNIT
F61	FUSE, SCRR OPTION UNIT
HE -1	ELEMENT, ELECTRIC HEAT 1
HE -2	ELEMENT, ELECTRIC HEAT 2
HE -3	ELEMENT, ELECTRIC HEAT 3
K15-1	CONTACTOR, ELECTRIC HEAT 1
K242	CONTACTOR, ELECTRIC HEAT 1
P2	PLUG, ELECTRIC HEAT
P393	PLUG, ELECTRIC HEAT CONTROL
S15	SWITCH, LIMIT PRIMARY ELECTRIC HEAT
S20	SWITCH, LIMIT SECONDARY ELECTRIC HEAT 1
S157	SWITCH, LIMIT SECONDARY ELECTRIC HEAT 2
TB2	TERMINAL STRIP, UNIT

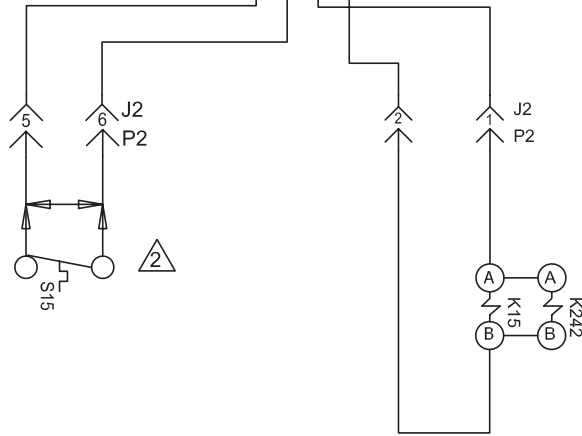

		KW	HE1	HE2	HE3	
072	060	036	7.5	7.5		
		- 048	15	15.0		
			22.5		15.0	7.5
			30		15.0	15.0

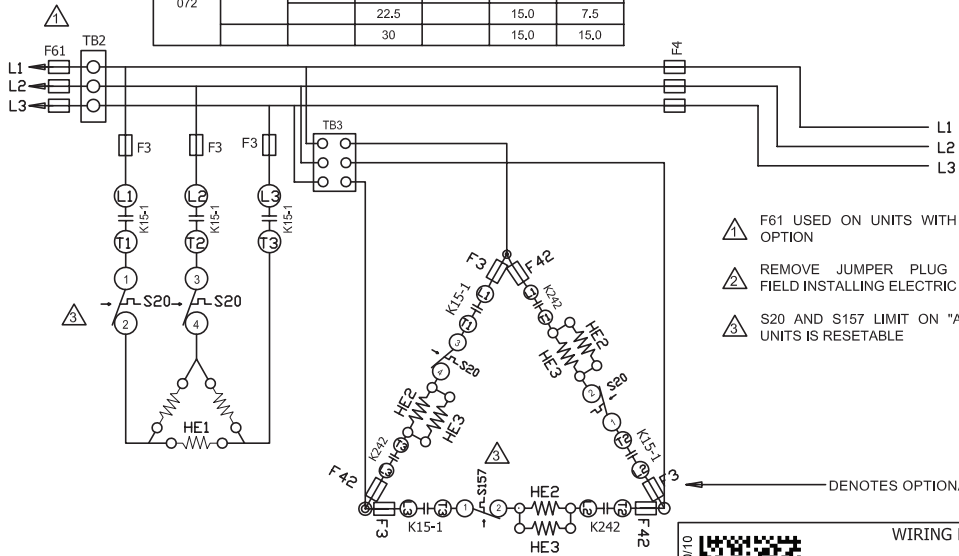

- F61 USED ON UNITS WITH SCRR OPTION
- REMOVE JUMPER PLUG WHEN FIELD INSTALLING ELECTRIC HEAT
- S20 AND S157 LIMIT ON "A" BOX UNITS IS RESETTABLE

— DENOTES OPTIONAL COMPONENTS

2020/10	WIRING DIAGRAM	10/20
538116-01		
HEATING		
ELECTRIC HEAT E1EH - 7.5, 15, 22.5, 30 - Y		
SECTION A		REV 0
Supersedes	New Form No. 538116-01	

E1EH-5, 75, 10, 22.5kW, P Volt

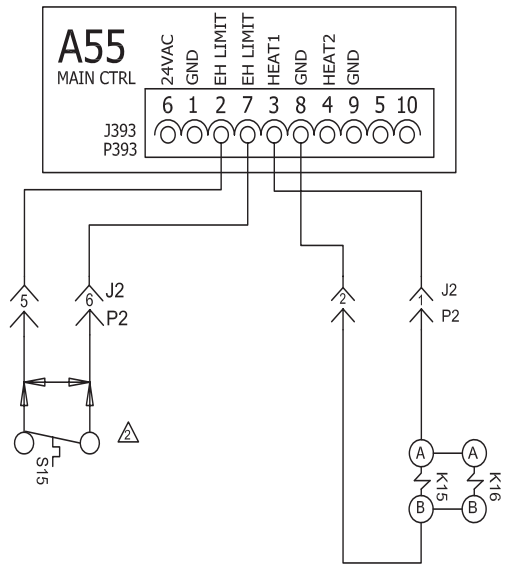

DESCRIPTION	
KEY	DESCRIPTION
A55	PANEL, MAIN
F3	FUSE, ELECTRIC HEAT
F4	FUSE, UNIT
F61	FUSE, UNIT - SCCR
HE -1	ELEMENT, ELECTRIC HEAT 1
HE -2	ELEMENT, ELECTRIC HEAT 2
HE -3	ELEMENT, ELECTRIC HEAT 3
HE -4	ELEMENT, ELECTRIC HEAT 4
HE -5	ELEMENT, ELECTRIC HEAT 5
HE -6	ELEMENT, ELECTRIC HEAT 6
J2	JACK, ELECTRIC HEAT
J265C	JACK, CONTACTOR RELAY
J266A	JACK, HEATING CONTROL STG 1
J271A,B	JACK, HEATING SENSORS STG 1
K15-1	CONTACTOR, ELECTRIC HEAT 1
K16-1	CONTACTOR, ELECTRIC HEAT 2
P2	PLUG, ELECTRIC HEAT
P7	PLUG, ELECTRIC HEAT SUB-BASE KIT
P265	PLUG, CONTACTOR RELAY
P266	PLUG, HEATING CONTROL
P271	PLUG, HEATING SENSORS STG 1
S15	SWITCH, LIMIT PRIMARY ELECTRIC HEAT
S20	SWITCH, LIMIT SECONDARY ELECTRIC HEAT 1
S157	SWITCH, LIMIT SECONDARY ELECTRIC HEAT 2
TB2	TERMINAL STRIP, UNIT

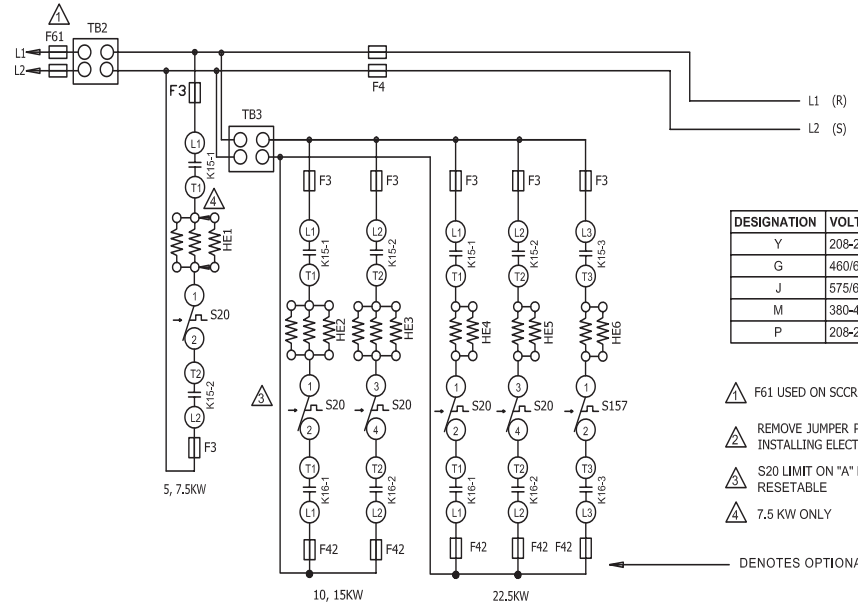

DESIGNATION	VOLTAGE
Y	208-230/60/3
G	460/60/3
J	575/60/3
M	380-420/50/3
P	208-230/60/1

- F61 USED ON SCCR UNITS ONLY
- REMOVE JUMPER PLUG WHEN FIELD INSTALLING ELECTRIC HEAT
- S20 LIMIT ON "A" BOX UNITS IS RESETTABLE
- 7.5 KW ONLY
- DENOTES OPTIONAL COMPONENTS

	KW	HE1	HE2	HE3	HE4	HE5	HE6
024 - 030	5.0	5.0					
036 - 048	10.0		5.0	5.0			
	7.5	7.5					
	15		7.5	7.5			
060	22.5				7.5	7.5	7.5

2023/10	WIRING DIAGRAM	10/23
538246-02		
HEATING		
ELECTRIC HEAT		
E1EH - 5, 7.5, 10, 15, 22.5 - P		
SECTION A		REV 0
Supersedes 538246-01	New Form No. 538246-02	

Heat Sequence of Operation

Blower Operation:

1- The A55 Unit Controller receives a demand from thermostat terminal G. A55 energizes blower motor B3 via programmed motor settings. Motor settings are field-adjustable.

First Stage Heat:

2- A55 Unit Controller receives W1 and G heating demand.

3- After A55 proves n.c. low pressure switch S87, n.c. high pressure switch S4, compressor contactor K1, Blower, and Fan is energized.

Sequence of Operation -E1EH 5, 7.5, 15, 22.5 - G, J Voltage

Heating Elements:

1- Terminal Strip TB2 is energized when the unit disconnect closes. TB2 supplies line voltage to electric heat elements HE1 and HE2. Elements are protected by fuse F3.

Second Stage Heat:

2- A55 Unit Controller receives W2 heating demand.

3- 24VAC is routed to the A55 Unit Controller (A55 routes power to the A38 if equipped) After A55 proves N.C. primary limit S15 the electric heat contactor K15 is energized. A55 energizes the blower and economizer.

4- 7.5kW, 5kW units - N.O. contacts K15-1 close energizing HE1.-

22.5kW units N.O. contacts K15-1 open energizing HE1 and HE2.

End of Second Stage Heat:

5- Heating demand is satisfied. Terminal W2 in the thermostat is de-energized.

6- Electric heat contactor K15 is de-energized.

7- 7.5kW, 15kW units - N.O. contacts K15-1 open de-energizing HE1..

22.5kW units N.O. contacts K15-1 open de-energizing HE1 and HE2.

Sequence of Operation -E1EH 5, 7.5, 15, 22.5 - P, Y Voltage

Heating Elements:

1- Terminal Strip TB2 is energized when the unit disconnect closes. TB2 supplies line voltage to electric heat elements HE1 and HE2. Elements are protected by fuse F3 and or F42.

Second Stage Heat:

2- A55 Unit Controller receives W2 heating demand.

3- 24VAC is routed to the A55 Unit Controller (A55 routes power to the A38 if equipped) After A55 proves N.C. primary limit S15 the electric heat contactor K15 is energized. A55 energizes the blower and economizer.

4- 7.5kW, 15kW units - N.O. contacts K15-1 close energizing HE1.-

22.5kW units N.O. contacts K15-1 open energizing HE2 and HE3.

End of Second Stage Heat:

5- Heating demand is satisfied. Terminal W2 in the thermostat is de-energized.

6- Electric heat contactor K15 is de-energized.

7- 7.5kW, 15kW units - N.O. contacts K15-1 open de-energizing HE1.

22.5kW units N.O. contacts K15-1 open de-energizing HE2 and HE3.

Optional factory-installed SCR (A38) All Voltages Control A38 will provide small amounts of power to the electric heat elements to efficiently maintain warm duct air temperatures when there is no heating demand. The SCR maintains duct air temperature based on input from a field-provided and installed thermostat (A104) and duct sensor (RT20). SCR is located in the compressor section on the left wall. Use only with a thermostat or specified DDC control system.

Use the instructions provided with the thermostat to set DIP switches as follows: S1 On, S2 Off, S3 Off. Use the instructions provided with the duct sensor to install sensor away from electric element radiant heat and in a location where discharge air is a mixed average temperature. Once power is supplied to unit, zero SCR as follows:

1- Adjust thermostat (A104) to minimum position.

2- Use a small screwdriver to slowly turn the ZERO potentiometer on the SCR until the LED turns solid red.

3- Very slowly adjust the potentiometer the opposite direction until the LED turns off.

Thermostat

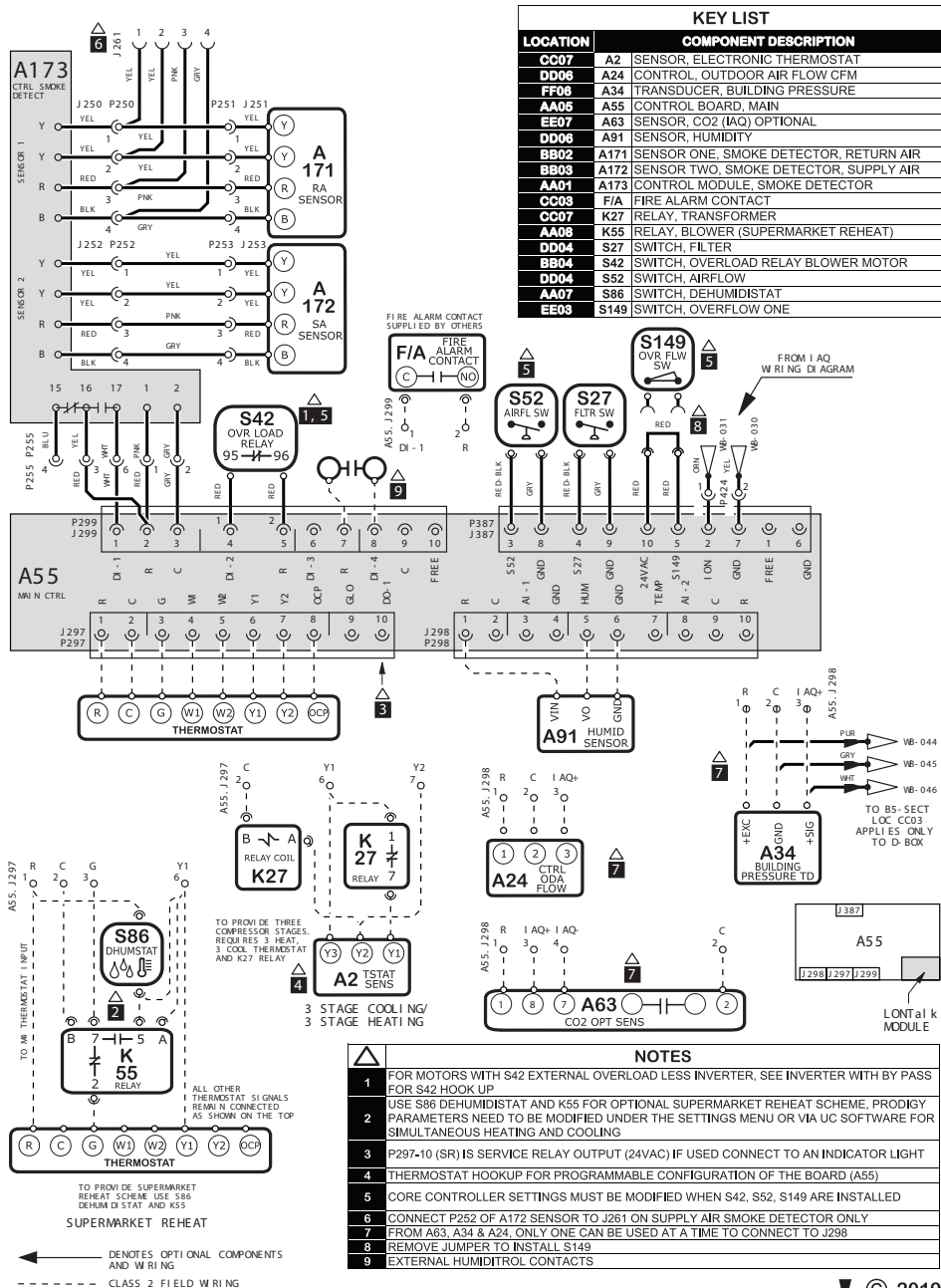

Model: LC, LG, LH, LD Series RTU
 Thermostat
 Voltage: All Voltages
 Supersedes: 538078-01 Form No: 538078-02 Rev: 0

HEATING SECTION A	COOLING SECTION B	COOLING SECTION B3/5	ACCS SECTION C	ACCS SECTION D
----------------------	----------------------	-------------------------	-------------------	-------------------

WIRING DIAGRAM FLOW

Economizer

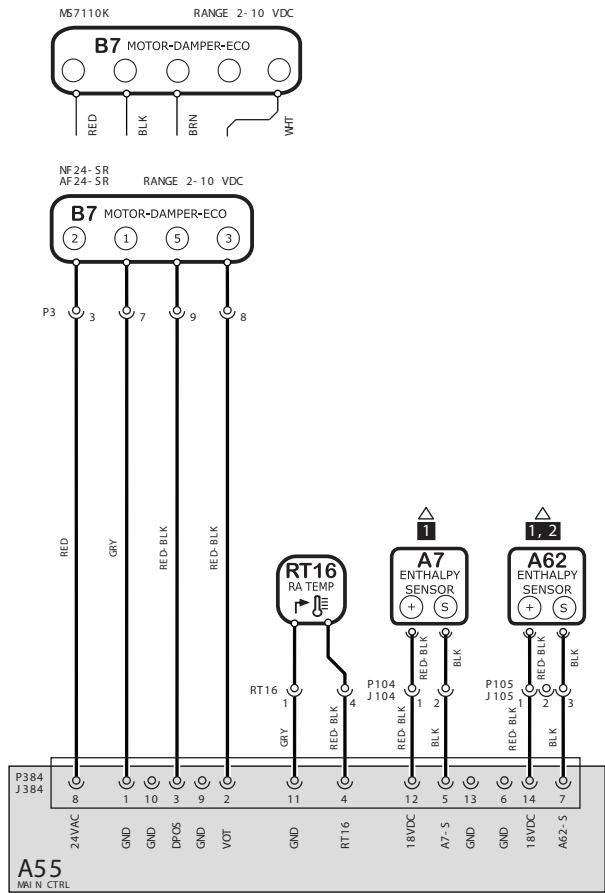

NOTES	
1	A7 AND A62 NOT USED FOR SENSIBLE TEMPERATURE CONTROL
2	FOR UNIT DIFFERENTIAL ENTHALPY CONTROL, ADD A62 RETURN AIR ENTHALPY SENSOR

KEY LIST	
LOCATION	COMPONENT DESCRIPTION
CC05	A7 SENSOR, SOLID STATE ENTHALPY
AA06	A55 CONTROL BOARD, MAIN
DD05	A62 SENSOR, ENTHALPY INDOOR
BB02	B7 MOTOR, DAMPER ECONOMIZER
CC05	RT16 SENSOR, RETURN AIR TEMP

Model: LC,LG,LH,LD,SC,SG Series
 Economizer & Motorized OAD
 Voltage: All Voltages
 Supersedes: N/A

© 2019

HTG SEC A	CLG SEC B	CLG SEC B3	ACCS SEC C	ACCS SEC D
-----------------	-----------------	------------------	------------------	------------------

WIRING DIAGRAM FLOW

Form No: 538072- 01 Rev: 2

IAQ Wiring Diagram

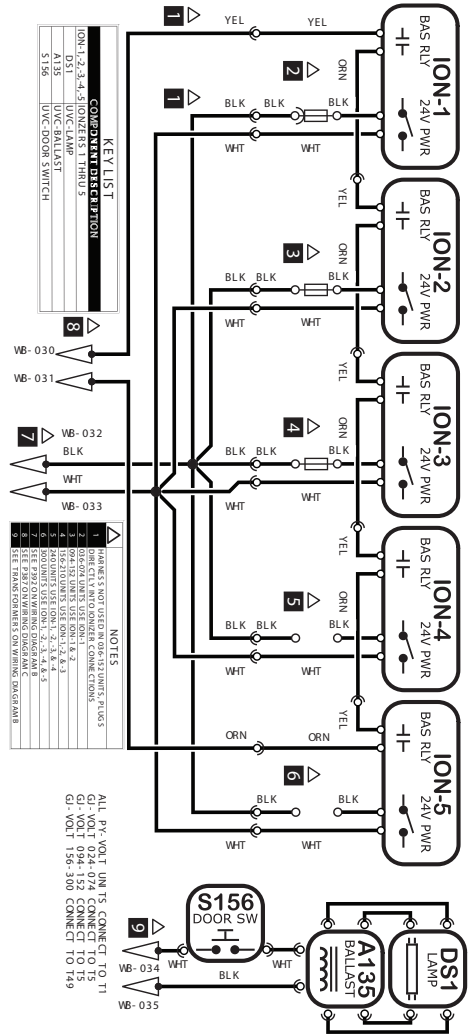

KEY LIST

ION-1, 2, 3, 4, 5	IONIZERS 1 THRU 5
DS1	UVC LAMP
S156	UVC LAMP
S156	UVC LAMP SWITCH

- VB-030
- VB-031
- VB-032
- VB-033

NOTES

1	HARVEST NOT FOR USE IN 06-12 UNITS, PLUGS
2	09-12 UNITS, USE ION-1, 2, 3, 4, 5
3	09-12 UNITS, USE ION-1, 2, 3, 4, 5
4	09-12 UNITS, USE ION-1, 2, 3, 4, 5
5	09-12 UNITS, USE ION-1, 2, 3, 4, 5
6	09-12 UNITS, USE ION-1, 2, 3, 4, 5
7	09-12 UNITS, USE ION-1, 2, 3, 4, 5
8	09-12 UNITS, USE ION-1, 2, 3, 4, 5
9	09-12 UNITS, USE ION-1, 2, 3, 4, 5

ALL 120V VOLT UNITS CONNECT TO T1
 ALL 240V VOLT UNITS CONNECT TO T1
 GI- VOLT 094-152 CONNECT TO T1
 GI- VOLT 156-300 CONNECT TO T49

MDL: IAQ WIRING DIAGRAM
 IONIZERS & UVC

VOLT: Y, G, J VOLT Rev: 0 538151-03

SUPSDS: N/A NO: 538151-03



Rev 0

Power Entry Options

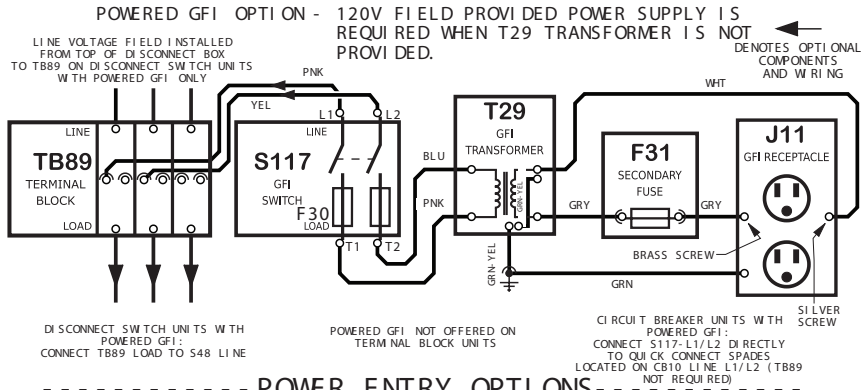

----- POWER ENTRY OPTIONS -----

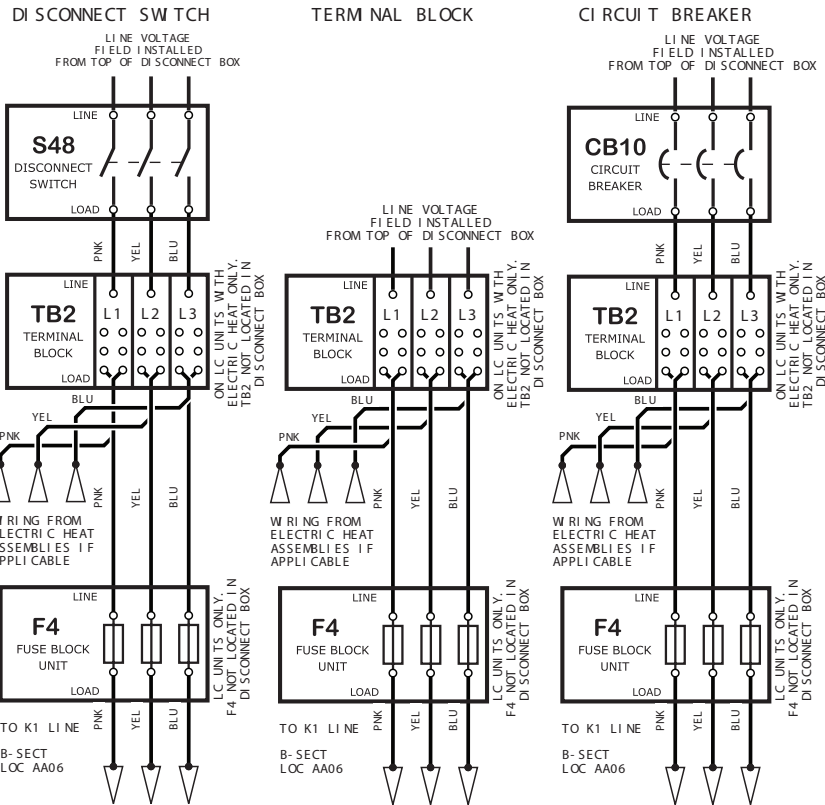

Model: LC, LG, LH, LD Series RTU
 Power Entry Options 024-074
 Voltage: All Voltages
 Supersedes: XXXXXX-XX Form No: 538234-01 Rev: 0

----- POWER ENTRY OPTI ONS -----

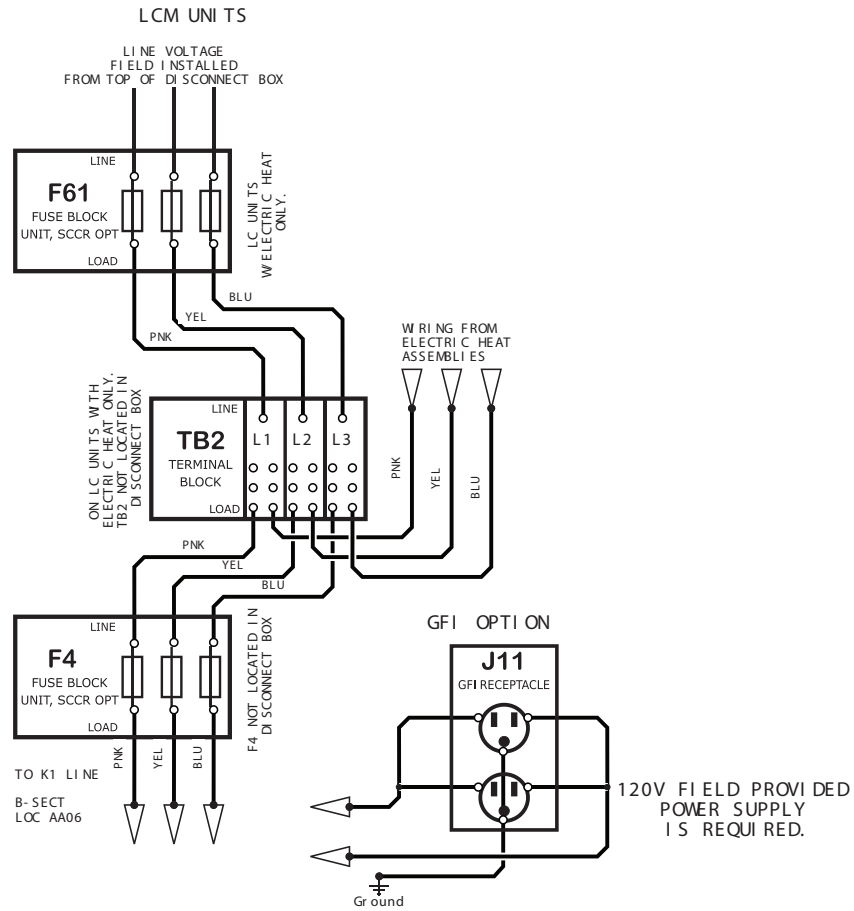

Model: LC, LH Series RTU WITH SCCR
 Power Entry Options 024 - 074
 Voltage: All Voltages
 Supersedes: N/A Form No: 538111-01 Rev: 1

120V FIELD PROVIDED
 POWER SUPPLY
 IS REQUIRED.