



**COMMERCIAL
PRODUCT SPECIFICATIONS**

Bulletin No. 211010

April 2024

Supersedes All previous versions

**ELITE®
SERIES**



072-090 Models



120-150 Models



180-240 Models

IEER up to 16.0

6 to 20 Tons

Cooling Capacity - 71,000 to 232,000 Btuh

MODEL NUMBER IDENTIFICATION

EL 120 X C S D T 1 Y

Brand/Family
EL = Elite® Series Product Line

Nominal Cooling Capacity - Tons
072 = 6 Tons
090 = 7.5 Tons
120 = 10 Tons
150 = 12.5 Tons
180 = 15 Tons
240 = 20 Tons

Refrigerant Type
X = R-410A

Unit Type
C = Split System Air Conditioner

Voltage
Y = 208/230V-3 phase-60Hz
G = 460V-3 phase-60Hz
J = 575V-3 phase-60Hz

Minor Design Sequence
1 = 1st Revision

Part Load Capability
T = Two-Stage Compressor

Refrigerant Circuits
S = Single Circuit
D = Dual Circuits

Cooling Efficiency
S = Standard Efficiency

FEATURE HIGHLIGHTS

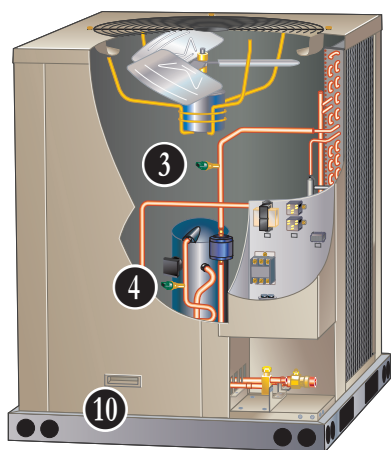

072-090 Models

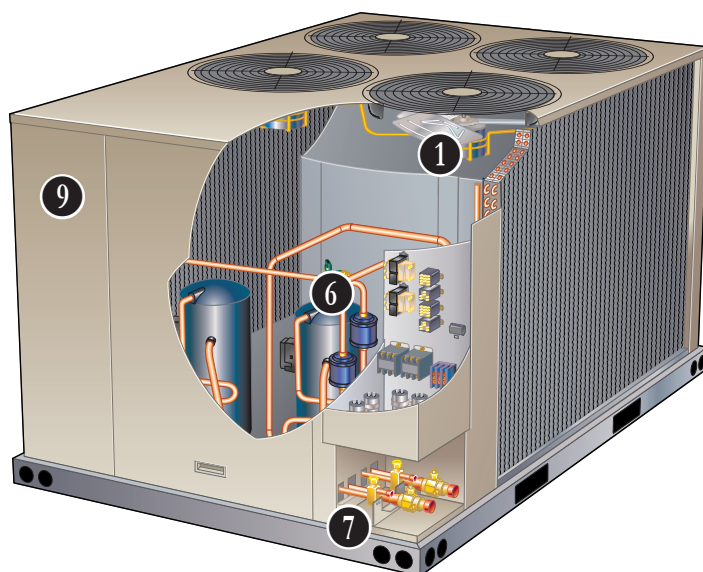

180-240 Models

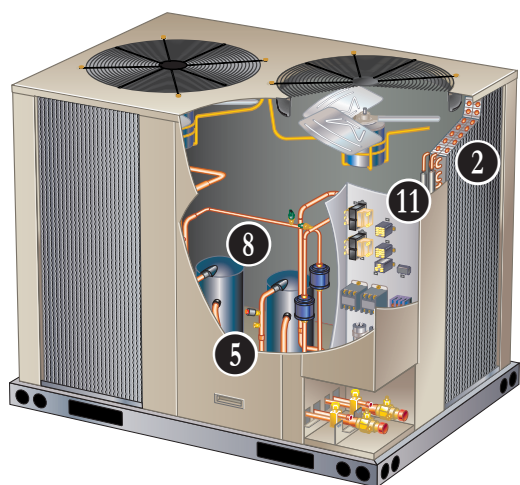

120 Model (150 Model Similar)

1. Outdoor Coil Fans
2. Copper Tube/Enhanced Fin Coils
3. High Pressure Switch
4. Low Pressure Switch
5. Loss of Charge Switch
6. Hi-Capacity Driers
7. Refrigerant Lines and Service Valves
8. Scroll Compressors
9. Heavy Gauge Pre-Painted Steel Cabinet
10. Heavy Duty Steel Base Rails
11. Control Box

CONTENTS

AHRI System Matches	13
Approvals And Warranty	3
Dimensions	15
- EL072XCSS EL090XCSS	15
- EL120XCSS EL120XCSD EL150XCSD	16
- EL180XCSD EL240XCSD	17
Features And Benefits	3
Model Number Identification	1
Optional Conventional Temperature Control Systems	7
Options / Accessories	12
Ratings	18
Sequence Of Operation	6
Sound Data	12
Specifications	8
- 6 Ton 7.5 Ton	8
- 10 Ton	9
- 12.5 Ton 20 Ton	10
Unit Clearances	14
Weight Data	11

APPROVALS AND WARRANTY

APPROVALS

- AHRI Standard 340/360 certified
- ETL listed
- All units meet cooling requirements of ASHRAE 90.1, IECC 2015, and California Code of Regulations, Title 24
- Tested in Lennox' Research Laboratory environmental test room or ETL certified environmental testing facility
- Sound tested in Lennox reverberant sound test room in accordance with test conditions included in AHRI Standard 270 or 370
- Unit and components UL, ULC, NEC and CEC bonded for grounding to meet safety standards for servicing
- All models are ASHRAE 90.1 energy efficiency compliant and meet or exceed requirements of Section 6.8
- All models meet DOE 2023 energy efficiency standards
- ISO 9001 Registered Manufacturing Quality System

WARRANTY

- Compressors - Limited five years in non-residential applications
- All other covered components - Limited one year

FEATURES AND BENEFITS

APPLICATIONS

- One Compressor - 6, 7.5, 10 ton models
- Two Compressors - 10, 12.5, 15 and 20 ton models
- Applicable to matching indoor air handlers and indoor add-on coils
- Shipped completely factory assembled, piped, and wired
- Test operated at the factory insuring proper operation

REFRIGERATION SYSTEM

R-410A Refrigerant

- Non-chlorine, ozone friendly

NOTE - Refrigerant is not furnished and must be field supplied.

1 Outdoor Coil Fans

- One Outdoor Fan - 072 and 090
- Two Outdoor Fans - 120 and 150
- Four Outdoor Fans - 180 and 240
- Direct drive fans moves large volumes of air uniformly through entire condenser coil for high refrigerant cooling capacity
- Totally enclosed fan motors
- Overload protected
- Rain shield furnished

2 Copper Tube/Enhanced Fin Coils

- Wrap-around "U" Shaped Coil - 072-090-120 models
- Two "L" Shaped Coils - 150-180-240 models
- Lennox designed and fabricated coils
- Ripple-edge aluminum fins
- Seamless copper tube construction
- Lanced fins for maximum fin surface exposure
- Fin collars grip tubing for maximum contact area
- Flared shoulder tubing connections
- Machine brazed silver soldering
- Factory tested under high pressure
- Completely accessible for cleaning

3 High Pressure Switches

- Protects the system from high pressure conditions
- Manual reset

4 Low Pressure Switches

- EL072XCSS, EL090XCSS, EL120XCSS single circuit models
- Shuts off unit if suction pressure falls below setting
- Loss of charge and freeze-up protection
- Automatic reset

5 Loss of Charge Switches

- EL120XCSD, EL150XCSD, EL180XCSD, EL240XCSD dual circuit models
- Shuts off unit if liquid line pressure falls below setting
- Provides loss of charge and freeze-up protection
- Automatic reset

6 Hi-Capacity Driers

- Traps moisture or dirt

7 Refrigerant Lines and Service Valves

- Suction and liquid lines located on corner of unit
- Sweat connections
- See dimension drawings
- Fully serviceable suction and liquid line service valves provide complete service access to refrigerant system
- Suction valve can be fully shut off, while liquid valve can be front seated to manage refrigerant charge while servicing system
- Accessible outside of unit cabinet

FEATURES AND BENEFITS

SCROLL COMPRESSORS

- 8 • Single Two-Stage Compressor - EL072**XCSS**, EL090**XCSS** and EL120**XCSS** single circuit models
- Dual Two-Stage Compressors - EL120**XCSD**, EL150**XCSD**, EL180**XCSD** and EL240**XCSD** dual-circuit models
- High efficiency with uniform suction flow
- Constant discharge flow, high volumetric efficiency and quiet operation
- Low gas pulses during compression reduces operational sound levels
- Compressor motor is internally protected from excessive current and temperature
- Compressor is installed in the unit on resilient rubber mounts for vibration free operation

Scroll Compressor Operation

- Two involute spiral scrolls matched together generate a series of crescent-shaped gas pockets between them
- During compression, one scroll remains stationary while the other scroll orbits around it
- Gas is drawn into the outer pocket, the pocket is sealed as the scroll rotates
- As the spiral movement continues, gas pockets are pushed to the center of the scrolls
- Volume between the pockets is simultaneously reduced
- When the pocket reaches the center, gas is now at high pressure and is forced out of a port located in the center of the fixed scrolls
- During compression, several pockets are compressed simultaneously resulting in a smooth continuous compression cycle
- Continuous flank contact, maintained by centrifugal force, minimizes gas leakage and maximizes efficiency
- Compressor is tolerant to the effects of slugging and contaminants
- If this occurs, scrolls separate, allowing liquid or contaminants to be worked toward the center and discharged
- A 24-volt DC solenoid valve inside the compressor controls staging

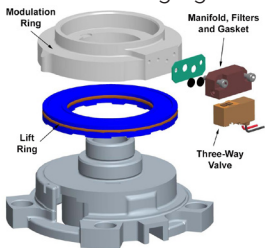

- When the 3-way solenoid is energized it moves the lift ring assembly to block the ports and the compressor operates at full-load or 100% capacity
- When the solenoid is de-energized the lift ring assembly moves to unblock the compressor

ports and the compressor operates at part-load or approximately 67% of its full-load capacity

- The “loading” and “unloading” of the two stage scroll is done “on the fly” without shutting off the single-speed compressor motor between stages

Crankcase Heater

- Crankcase heater(s) prevents migration of liquid refrigerant into compressor(s) and ensures proper compressor lubrication

CABINET

- 9 • Heavy-gauge, pre-painted steel cabinet
- Removable panels for unit servicing
- 10 • Heavy duty steel base rails raise the unit off of mounting surface
- Unit lifting holes and forklift slots furnished in base rails
- See dimension drawings
- 11 • Control Box
- Control box located in separate compartment in unit cabinet
- All controls are pre-wired at the factory
- Control box is large enough for field installed DDC or other field supplied control modules

Options/Accessories

Factory Installed

Corrosion Protection

- Available for enhanced condenser coil corrosion protection
- Polymeric epoxy coating deposited by electrical transport (electrophoresis) using a process known as electrocoat (e-coat)
- Painted base pan furnished

Field Installed

Combination Coil/Hail Guards

- Heavy gauge steel frame with expanded metal mesh to protect the outdoor coil from damage

FEATURES AND BENEFITS

CONTROLS

Options/Accessories

Field Installed

Low Ambient Control

- Air conditioning units operate satisfactorily down to 45°F outdoor air temperature without any additional controls
- Kit allows unit operation down to 0°F
- Head pressure speed controller reduces outdoor fan operation during low ambient conditions until head pressure rises to the setpoint
- Pressure transducers are mounted on the liquid lines
- High pressure switches are furnished to replace existing switches
- Wiring harnesses are furnished for simple plug-in wiring to fans and controller

Indoor Air Quality (CO₂) Sensors

- Monitors CO₂ levels
- Adjusts economizer dampers as needed

Thermostat

- Thermostat is not furnished with unit and must be ordered extra

Aftermarket Unit Controller Options

- See Options/Accessories table for selection

Furnace Twinning Panel

- Required to operate two identical furnaces simultaneously from a single thermostat
- For single stage conventional (1 heat/1 cool), multi-stage conventional (2 heat/2 cool) and heat pump (3 heat/2 cool) equipment
- Can be used with common or separate ducted systems
- Contains PC Control Board with terminal strip connections for thermostat and HVAC equipment
- LEDs indicate system operating status
- Uses standard 18-gauge thermostat wire
- Power Supply: 24 VAC, 40VA (transformer not furnished)
- Mounting base with hardware furnished
- Dimensions (H x W x D): 10 x 5 x 2 in.

NOTE - Only identical furnaces should be twinned in order to ensure that both furnace blowers start at the same time. If furnaces are not identical, back draft dampers can be installed in either the supply or return duct.

Up to four identical furnaces can be twinned. Requires two panels that are wired together.

Aftermarket Unit Controller Options

- See Options/Accessories table for selection

ELECTRICAL

Field Installed

GFI Service Outlets (2)

- 115V ground fault circuit interrupter (GFCI) type
- Non-powered
- Field wired

SEQUENCE OF OPERATION

The outdoor unit and indoor unit cycle on demand from the room thermostat.

For details on the outdoor unit component operation based on thermostat demand, refer to the table below.

EL072XCSS, EL090XCSS

Thermostat Demand	² Input Signals at Terminal Strip	Compressor Output		Fan			
(¹ Key Number)	(TB14)	(B1)	---	(B4)	---	---	---
STANDBY	R	OFF	---	OFF	---	---	---
COOLING 1	C1	LOW	---	ON	---	---	---
COOLING 2	C1+C2	HIGH	---	ON	---	---	---

EL120XCSS

Thermostat Demand	² Input Signals at Terminal Strip	Compressor Output		Fans			
(¹ Key Number)	(TB14)	(B1)	---	(B4)	(B5)	---	---
STANDBY	R	OFF	---	OFF	OFF	---	---
COOLING 1	C1	LOW	---	ON	ON	---	---
COOLING 2	C1+C2	HIGH	---	ON	ON	---	---

EL120XCSD

Thermostat Demand	² Input Signals at Terminal Strip	Compressor Output		Fans			
(¹ Key Number)	(TB14)	(B1)	(B2)	(B4)	(B5)	---	---
STANDBY	R	OFF	OFF	OFF	OFF	---	---
COOLING 1	C1	LOW	OFF	ON	ON	---	---
COOLING 2	C1+C2	LOW	LOW	ON	ON	---	---
COOLING 3	C1+C2+C3	HIGH	HIGH	ON	ON	---	---

EL150XCSD

Thermostat Demand	² Input Signals at Terminal Strip	Compressor Output		Fans			
(¹ Key Number)	(TB14)	(B1)	(B2)	(B4)	(B5)	---	---
STANDBY	R	OFF	OFF	OFF	OFF	---	---
COOLING 1	C1	LOW	OFF	ON	OFF	---	---
COOLING 2	C1+C2	LOW	LOW	ON	ON	---	---
COOLING 3	C1+C2+C3	HIGH	HIGH	ON	ON	---	---

EL180XCSD, EL240XCSD

Thermostat Demand	² Input Signals at Terminal Strip	Compressor Output		Fans			
(¹ Key Number)	(TB14)	(B1)	(B2)	(B4)	(B5)	(B21)	(B22)
STANDBY	R	OFF	OFF	OFF	OFF	OFF	OFF
COOLING 1	C1	LOW	OFF	ON	ON	OFF	OFF
COOLING 2	C1+C2	LOW	LOW	ON	ON	ON	ON
COOLING 3	C1+C2+C3	HIGH	HIGH	ON	ON	ON	ON

¹ Refer to Component Label or Wiring Diagram for key numbers.

² 24V input signals measured between one TB14 connection listed and TB14-C connection.

OPTIONAL CONVENTIONAL TEMPERATURE CONTROL SYSTEMS

CS7500 Commercial 7-Day Programmable Thermostat



- Four-Stage Heating / Three-Stage Cooling
- Universal Multi-Stage
- Intuitive Touchscreen Interface
- Automatic Changeover between Heating and Cooling
- Full Seven-Day Programming
- Four Time Periods Per Day
- Temperature and Humidity Control
- One-Touch Away Mode
- Holiday Scheduling
- Smooth Setback Recovery (SSR)
- Performance Reports
- Notifications/Reminders
- Dehumidification Control for Split Systems and Rooftop Units
- Economizer Relay Control
- Backlit Display
- Wallplate Furnished
- FDD, ASHRAE and IECC Compliant

CS3000 Commercial 5-2 Day Programmable Thermostat

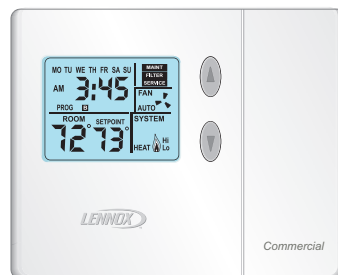

- Two-Stage Heating / Two-Stage Cooling
- Conventional Systems
- Intuitive Interface
- 5-2 Day Programming
- Program Hold
- Remote Indoor Temperature Sensing
- Smooth Setback Recovery (SSR)
- Economizer Relay Control
- Maintenance/Filter/Service Reminders
- Backlit Display
- Wallplate Furnished
- Simple Up and Down Temperature Control

Optional Accessory

Cooling Stage-Up Timer Relay

- Allows the unit to attain an additional stage of cooling without the need for extra thermostat connections
- Adjustable - 1 to 1023 seconds
- Mounts internal to unit

OPTIONAL CONVENTIONAL TEMPERATURE CONTROL SYSTEMS

Description	Catalog No.	
CS7500 Commercial 7-Day Programmable Thermostat		
CS7500 7-Day Thermostat	24K41	
Sensors/Accessories	² Remote non-adjustable wall-mount 20k	47W36
	² Remote non-adjustable wall-mount 10k	47W37
	Remote non-adjustable discharge air (duct mount)	19L22
	Outdoor temperature sensor	X2658
CS3000 Commercial 5-2 Day Programmable Thermostat		
CS3000 5-2 Day Thermostat	11Y05	
Sensors/Accessories	Remote non-adjustable wall mount 10k averaging	47W37
	Thermostat wall mounting plate	X2659
Optional Accessory		
	Cooling Stage-Up Timer Relay	24G40
Universal Thermostat Guard with Lock (clear)		
	Inside Dimensions (H x W) 5 7/8 x 8 3/8 in.	39P21

¹ Up to nine of the same type remote temperature sensors can be connected in parallel.

² Remote wall-mount sensors can be applied in any of the following combinations:
 One Sensor - (1) 47W36, Two Sensors - (2) 47W37, Three Sensors - (2) 47W36 and (1) 47W37
 Four Sensors - (4) 47W36, Five Sensors - (3) 47W36 and (2) 47W37

SPECIFICATIONS
6 TON | 7.5 TON

General Data		Model No.	EL072XCSS	EL090XCSS
Nominal Size - Tons			6	7.5
Connections (sweat)	Liquid line - in. (o.d)		(1) 3/8	(1) 5/8
	Suction line - in. (o.d)		(1) 1-1/8	(1) 1-1/8
Refrigerant (R-410A)	Factory Charge	R-410A holding charge (2 lbs. per circuit)		
	No. of Circuits		1	1
	¹ Field charge (25 ft. line set)		18 lbs. 0 oz. (includes holding charge)	20 lbs. 0 oz. (includes holding charge)
Compressor			(1) Two Stage Scroll	(1) Two Stage Scroll
Condenser Coil	Net face area - sq. ft. Outer coil		29.3	29.3
	Inner coil		14.2	28.4
	Tube diameter - in. & no. of rows		3/8 - 1.5	3/8 - 2
	Fins per inch		20	20
Condenser Fan(s)	Diameter - in. & no. of blades		(1) 24 - 3	(1) 24 - 4
	Motor hp		(1) 1/3	(1) 1/2
	Total air volume - cfm		4700	5600
	Rpm		1075	1075
	Watts		400	580

ELECTRICAL DATA

Line voltage data - 60 hz - 3 phase		208/230V	460V	575V	208/230V	460V	575V
² Maximum Overcurrent Protection (amps)		40	20	15	60	25	20
³ Minimum circuit ampacity		25	12	9	37	17	13
Compressor	No. of Compressors	1	1	1	1	1	1
	Rated load amps	17.6	8.5	6.3	26.9	12	9
	Locked rotor amps	136	66.1	55.3	165	94	65
Condenser Fan Motor (1 phase)	No. of motors	1	1	1	1	1	1
	Full load amps	2.4	1.3	1	3	1.5	1.2
	Locked rotor amps	4.3	2.4	1.9	6	3	2.9

NOTE - All units have a minimum Short Circuit Current Rating (SCCR) of 5000 amps.

NOTE - Extremes of operating range are plus and minus 10% of line voltage.

¹ Approximate field provided charge with 25 ft. line set. Refer to unit installation instructions for detailed charging information.

Refer to the Lennox Refrigerant Piping Manual to determine refrigerant charge required with longer length refrigerant lines.

² HACR type circuit breaker or fuse.

³ Refer to National or Canadian Electrical Code manual to determine wire, fuse and disconnect size requirements.

SPECIFICATIONS - 10 TON
10 TON

General Data		Model No.	EL120XCSS	EL120XCSD	
		Nominal Size - Tons	10	10	
Connections (sweat)	Liquid line - in. (o.d)		(1) 5/8	(2) 3/8	
	Suction line - in. (o.d)		(1) 1-1/8	(2) 1-1/8	
Refrigerant (R-410A)	Factory Charge	R-410A holding charge (2 lbs. per circuit)			
	No. of Circuits		1	2	
	¹ Field charge (25 ft. line set)	Circuit 1	23 lbs. 0 oz. (includes holding charge)	12 lbs. 0 oz. (includes holding charge)	
		Circuit 2	- - -	12 lbs. 0 oz. (includes holding charge)	
Compressor			(1) Two Stage Scroll	(2) Two Stage Scroll	
Condenser Coil	Net face area - sq. ft. Outer coil		29.3	29.3	
	Inner coil		28.4	28.4	
	Tube diameter - in. & no. of rows		3/8 - 2	3/8 - 2	
	Fins per inch		20	20	
Condenser Fan(s)	Diameter - in. & no. of blades		(2) 24 - 3	(2) 24 - 3	
	Motor hp		(2) 1/3	(2) 1/3	
	Total air volume - cfm		8300	8300	
	Rpm		1075	1075	
	Watts		830	830	

ELECTRICAL DATA

Line voltage data - 60 hz - 3 phase		208/230V	460V	575V	208/230V	460V	575V
² Maximum Overcurrent Protection (amps)		80	35	25	50	20	15
³ Minimum circuit ampacity		49	22	16	37	18	14
Compressor	No. of Compressors	1	1	1	2	2	2
	Rated load amps (total)	34.6	14.8	11.1	14 (28)	6.5 (13)	4.9 (9.8)
	Locked rotor amps (total)	240	130	93.7	93 (186)	60 (120)	41 (82)
Condenser Fan Motor (1 phase)	No. of motors	2	2	2	2	2	2
	Full load amps (total)	2.4 (4.8)	1.3 (2.6)	1 (2)	2.4 (4.8)	1.3 (2.6)	1 (2)
	Locked rotor amps (total)	4.3 (8.6)	2.4 (4.8)	1.9 (3.8)	4.3 (8.6)	2.4 (4.8)	1.9 (3.8)

NOTE - All units have a minimum Short Circuit Current Rating (SCCR) of 5000 amps.

NOTE - Extremes of operating range are plus and minus 10% of line voltage.

¹ Approximate field provided charge with 25 ft. line set. Refer to unit installation instructions for detailed charging information. Refer to the Lennox Refrigerant Piping Manual to determine refrigerant charge required with longer length refrigerant lines.

² HACR type circuit breaker or fuse.

³ Refer to National or Canadian Electrical Code manual to determine wire, fuse and disconnect size requirements.

SPECIFICATIONS

12.5 TON | 20 TON

General Data		Model No.	EL150XCSD	EL180XCSD	EL240XCSD
Nominal Size - Tons			12.5	15	20
Connections (sweat)	Liquid line - in. (o.d)		(2) 3/8	(2) 5/8	(2) 5/8
	Suction line - in. (o.d)		(2) 1-1/8	(2) 1-1/8	(2) 1-1/8
Refrigerant (R-410A)	Factory Charge	R-410A holding charge (2 lbs. per circuit)			
	No. of Circuits		2	2	2
	¹ Field charge (25 ft. line set)	Circuit 1	15 lbs. 0 oz. (includes holding charge)	24 lbs. 0 oz. (includes holding charge)	22 lbs. 4 oz. (includes holding charge)
Circuit 2		15 lbs. 0 oz. (includes holding charge)	24 lbs. 0 oz. (includes holding charge)	23 lbs. 3 oz. (includes holding charge)	
Compressor			(2) Two Stage Scroll	(2) Two Stage Scroll	(2) Two Stage Scroll
Condenser Coil	Net face area - sq. ft. Outer coil		34.2	58.7	58.7
	Inner coil		33.3	57.7	57.7
	Tube diameter - in. & no. of rows		3/8 - 2	3/8 - 2	3/8 - 2
	Fins per inch		20	20	20
Condenser Fan(s)	Diameter - in. & no. of blades		(2) 24 - 4	(4) 24 - 3	(4) 24 - 3
	Motor hp		(2) 1/2	(4) 1/3	(4) 1/3
	Total air volume - cfm		10,300	16,600	16,600
	Rpm		1075	1075	1075
	Watts		1130	1660	1660

ELECTRICAL DATA

Line voltage data - 60 hz - 3 phase		208/230V	460V	575V	208/230V	460V	575V	208/230V	460V	575V
² Maximum Overcurrent Protection (amps)		60	30	20	90	40	30	110	50	40
³ Minimum circuit ampacity		46	23	17	71	33	25	88	39	29
Compressor	No. of Compressors	2	2	2	2	2	2	2	2	2
	Rated load amps (total)	17.6 (35.2)	8.5 (17)	6.3 (12.6)	26.9 (53.8)	12 (24)	9 (18)	34.6 (69.2)	14.8 (29.6)	11.1 (22.2)
	Locked rotor amps (total)	136 (272)	66.1 (132.2)	55.3 (110.6)	164 (328)	100 (200)	78 (156)	240 (480)	130 (260)	93.7 (187.4)
Condenser Fan Motor (1 phase)	No. of motors	2	2	2	4	4	4	4	4	4
	Full load amps (total)	3 (6)	1.5 (3)	1.2 (2.4)	2.4 (9.6)	1.3 (5.2)	1 (4)	2.4 (9.6)	1.3 (5.2)	1 (4)
	Locked rotor amps (total)	6 (12)	3 (6)	2.9 (5.8)	4.3 (17.2)	2.4 (9.6)	1.9 (7.6)	4.3 (17.2)	2.4 (9.6)	1.9 (7.6)

NOTE - All units have a minimum Short Circuit Current Rating (SCCR) of 5000 amps.

NOTE - Extremes of operating range are plus and minus 10% of line voltage.

¹ Approximate field provided charge with 25 ft. line set. Refer to unit installation instructions for detailed charging information. Refer to the Lennox Refrigerant Piping Manual to determine refrigerant charge required with longer length refrigerant lines.

² HACR type circuit breaker or fuse.

³ Refer to National or Canadian Electrical Code manual to determine wire, fuse and disconnect size requirements.

WEIGHT DATA

Model No.	Net		Shipping	
	lbs.	kg	lbs.	kg
072XCSS	318	144	338	153
090XCSS	345	157	365	166
120XCSS	452	205	477	216
120XCSD	486	220	511	232
150XCSD	535	243	560	254
180XCSD	784	356	809	367
240XCSD	864	392	889	403

OPTIONS / ACCESSORIES**COMBINED COIL/HAIL GUARDS**

072, 090	40	18	45	20
120	45	20	50	23
150	45	20	50	23
180, 240	90	41	100	45

OPTIONS / ACCESSORIES

Item Description	Catalog No.	EL 072	EL 090	EL 120	EL 120	EL 150	EL 180	EL 240
		XCSS	XCSS	XCSS	XCSD	XCSD	XCSD	XCSD
CABINET								
Combined Coil/Hail Guards	13T29	X	X					
	13T30			X	X			
	13T32					X		
	13T37						X	X
Corrosion Protection	Factory	O	O	O	O	O	O	O

CONTROLS

BACnet® Module	17A08	X	X	X				
BACnet® Sensor with Display	97W23	X	X	X				
BACnet® Sensor without Display	97W24	X	X	X				
Low Ambient Control (0°F)	16F18	X	X					
	16F26			X				
	16F24				X			
	24K11					X		
	16F25						X	X
Furnace Twinning Panel	Y3653	X	X	X				

ELECTRICAL

GFI Service Outlets	15 amp non-powered, field-wired (208/230V, 460V only)	74M70	X	X	X	X	X	X	X
	20 amp non-powered, field-wired (575V only)	67E01	X	X	X	X	X	X	X

INDOOR AIR QUALITY

Sensor - Wall-mount, off-white plastic cover with LCD display	77N39	X	X	X	X	X	X	X
Sensor - Wall-mount, off-white plastic cover, no display	23V86	X	X	X	X	X	X	X
Sensor - Black plastic case with LCD display, rated for plenum mounting	87N52	X	X	X	X	X	X	X
Sensor - Wall-mount, black plastic case, no display, rated for plenum mounting	87N54	X	X	X	X	X	X	X
CO ₂ Sensor Duct Mounting Kit	23Y47	X	X	X	X	X	X	X
Aspiration Box - for duct mounting non-plenum rated CO ₂ sensor (77N39)	90N43	X	X	X	X	X	X	X

NOTE - The catalog and model numbers that appear here are for ordering field installed accessories only.

O - Factory Installed with extended lead time.

X - Field Installed

SOUND DATA

1 Unit Model	Octave Band Sound Power Levels dBA, re 10 ⁻¹² Watts Center Frequency - HZ							1 Sound Rating Number (dBA)	2 Estimated Sound Pressure Level at Distance From Unit (dBA at distance in ft.)				
	125	250	500	1000	2000	4000	8000		3	5	10	15	50
EL072XCSS	65	68	73	76	72	68	63	81	74	69	63	60	49
EL090XCSS	64	69	73	77	74	70	63	81	74	69	63	60	49
EL120XCSS	70	77	82	81	77	75	71	86	79	74	68	65	54
EL120XCSD	71	77	80	80	77	72	67	85	78	73	67	64	53
EL150XCSD	68	77	80	82	78	73	65	86	79	74	68	65	54
EL180XCSD	73	80	83	83	79	74	66	88	81	76	70	67	56
EL240XCSD	73	80	85	84	80	78	74	89	82	77	71	68	57

NOTE - The octave sound power data does not include tonal correction.

¹ Tested according to AHRI Standard 270-2008 test conditions. Sound rating Number is the overall A-Weighted Sound Power Level, (LWA), dB (100 Hz to 10,000 Hz).

² Estimated sound pressure level at distance based on AHRI Standard 275-2010 method for equipment located on the ground, roof, or on side of building wall with no adjacent reflective surface within 9.8 feet. Sound pressure levels will increase based on changes to assumptions. For other applications, refer to AHRI Standard 275.

AHRI SYSTEM MATCHES
ONE OUTDOOR UNIT + ONE INDOOR UNIT

Model	Cooling Btuh	IEER	EER	Air Handler	Expansion Device	AHRI Reference
EL072XCSS	71,000	16.00	12.00	EL072XASS	Factory TXV	210666000
EL072XCSS	73,000	14.80	11.20	EL090XASD	Factory TXV	210666001
EL090XCSS	89,000	14.80	11.20	EL090XASD	Factory TXV	210666002
EL090XCSS	90,000	14.80	11.20	EL120XASD	Factory TXV	210666003
EL120XCSS	115,000	14.80	11.20	EL120XASD	Factory TXV	210666004
EL120XCSD	115,000	14.80	11.20	EL120XASD	Factory TXV	210666005
EL150XCSD	136,000	14.20	11.00	EL150XASD	Factory TXV	210666006
EL150XCSD	142,000	14.20	11.00	EL180XASD	Factory TXV	210666007
EL180XCSD	176,000	14.20	11.00	EL180XASD	Factory TXV	210666008
EL180XCSD	196,000	14.20	11.00	EL240XASD	Factory TXV	210666009
EL240XCSD	228,000	14.20	11.00	EL240XASD	Factory TXV	210666010

NOTES - Units with capacity of 65,000 Btuh or greater are AHRI Certified to AHRI Standard 340/360: 95°F outdoor air temperature, 80°F db/67°F wb entering evaporator air (minimum external duct static pressure) with 25 ft. of connecting refrigerant lines.

AHRI SYSTEM MATCHES
TWO OUTDOOR UNITS + ONE INDOOR UNIT

Model	Cooling Btuh	IEER	EER	Indoor Coil or Air Handler	Expansion Device	AHRI Reference
(2) EL090XCSS	170,000	14.20	11.00	EL180XASD	Factory TXV	210666045
(2) EL120XCSS	232,000	14.40	11.00	EL240XASD	Factory TXV	210666046

NOTES - Units with capacity of 65,000 Btuh or greater are AHRI Certified to AHRI Standard 340/360: 95°F outdoor air temperature, 80°F db/67°F wb entering evaporator air (minimum external duct static pressure) with 25 ft. of connecting refrigerant lines.

AHRI SYSTEM MATCHES
ONE OUTDOOR UNIT + TWO INDOOR UNITS

Model	Cooling Btuh	IEER	EER	Indoor Coil or Air Handler	Furnace	Expansion Device	AHRI Reference
EL090XCSS	92,000	14.80	11.20	(2) CX35-60D	(2) EL296UH135XE60D	Factory TXV	210666013
EL090XCSS	95,000	14.80	11.20	(2) CX35-60C	(2) EL280UH110E48C	Factory TXV	210666014
EL090XCSS	95,000	14.80	11.20	(2) CX35-60C	(2) EL280UH110E60C	Factory TXV	210691275
EL090XCSS	95,000	14.80	11.20	(2) CX35-60C	(2) EL280UH110XE60C	Factory TXV	210691276
EL090XCSS	95,000	14.80	11.20	(2) CX35-60C	(2) EL296UH110XE60C	Factory TXV	210691277
EL120XCSS	110,000	14.80	11.20	(2) CH23-68	(2) EL280UH110E60C	12J20 or Y8737 (Order 2)	210691278
EL120XCSS	110,000	14.80	11.20	(2) CH23-68	(2) EL280UH110XE60C	12J20 or Y8737 (Order 2)	210691279
EL120XCSS	110,000	14.80	11.20	(2) CH23-68	(2) EL296UH110XE60C	12J20 or Y8737 (Order 2)	210666015
EL120XCSS	110,000	14.80	11.20	(2) CX35-60C	(2) EL280UH110E60C	Factory TXV	210691280
EL120XCSS	110,000	14.80	11.20	(2) CX35-60C	(2) EL280UH110XE60C	Factory TXV	210691281
EL120XCSS	110,000	14.80	11.20	(2) CX35-60C	(2) EL296UH110XE60C	Factory TXV	210666016
EL120XCSS	110,000	14.80	11.20	(2) CX35-60D	(2) EL296UH135XE60D	Factory TXV	210666017
EL180XCSD	180,000	14.20	11.00	(2) EL090XASD	---	Factory TXV	210666011
EL240XCSD	232,000	14.20	11.00	(2) EL120XASD	---	Factory TXV	210666012

NOTES - Units with capacity of 65,000 Btuh or greater are AHRI Certified to AHRI Standard 340/360: 95°F outdoor air temperature, 80°F db/67°F wb entering evaporator air (minimum external duct static pressure) with 25 ft. of connecting refrigerant lines.

UNIT CLEARANCES

EL072 and EL090

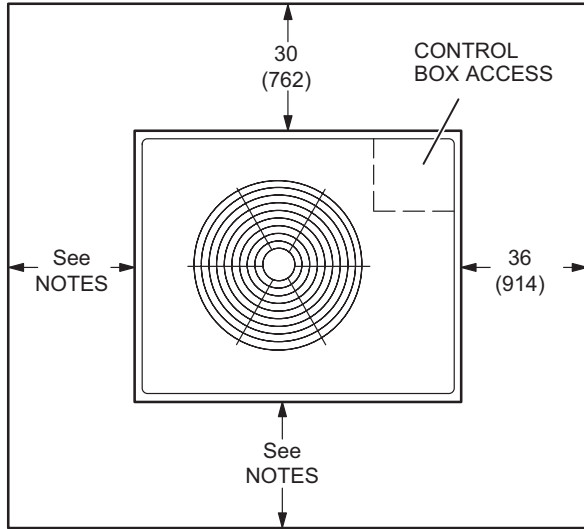

NOTES:

Clearance to one of the remaining two sides may be 12 in. (305 mm) and the final side may be 6 in. (152 mm).

A clearance of 24 in. (610 mm) must be maintained between two units.

48 in. (1219 mm) clearance required on top of unit.

EL120 and EL150

NOTES:

Clearance to one of the remaining two sides may be 12 in. (305 mm) and the final side may be 6 in. (152 mm).

A clearance of 24 in. (610 mm) must be maintained between two units.

48 in. (1219 mm) clearance required on top of unit.

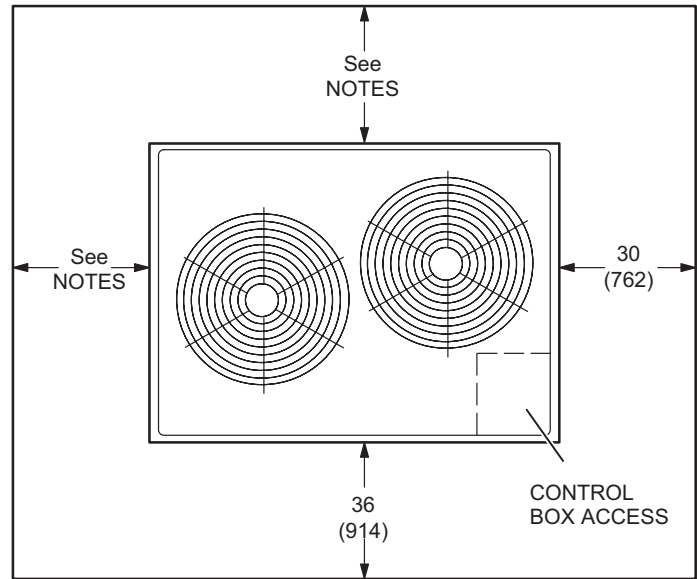

EL180 and EL240

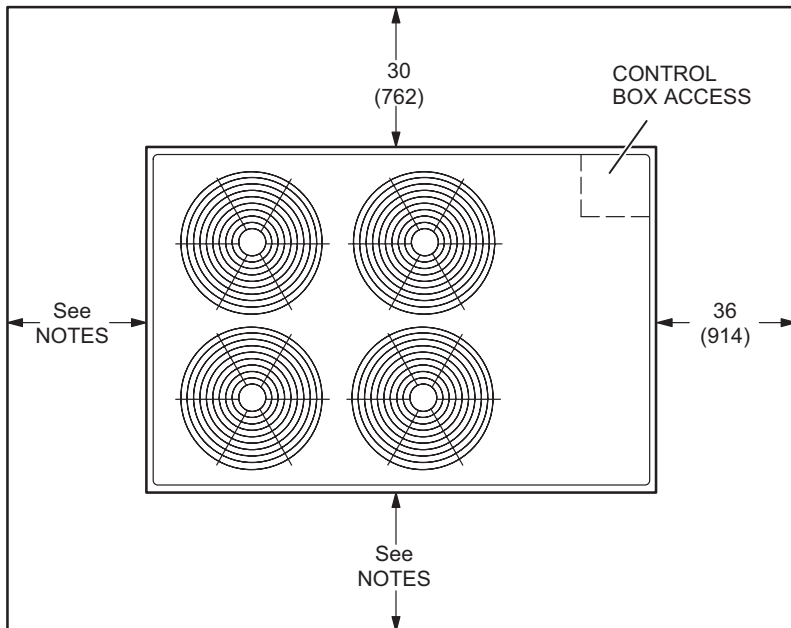

NOTES:

Clearance to one of the remaining two sides may be 12 in. (305 mm) and the final side may be 6 in. (152 mm).

A clearance of 24 in. (610 mm) must be maintained between two units.

48 in. (1219 mm) clearance required on top of unit.

DIMENSIONS

EL072XCSS | EL090XCSS

Model No.	CORNER WEIGHTS								CENTER OF GRAVITY			
	AA		BB		CC		DD		EE		FF	
	lbs.	kg	lbs.	kg	lbs.	kg	lbs.	kg	in.	mm	in.	mm
EL072XCSS	66	30	73	33	97	44	82	37	23-1/4	591	19-1/4	489
EL090XCSS	75	34	89	40	112	51	88	40	25	635	20-1/4	514

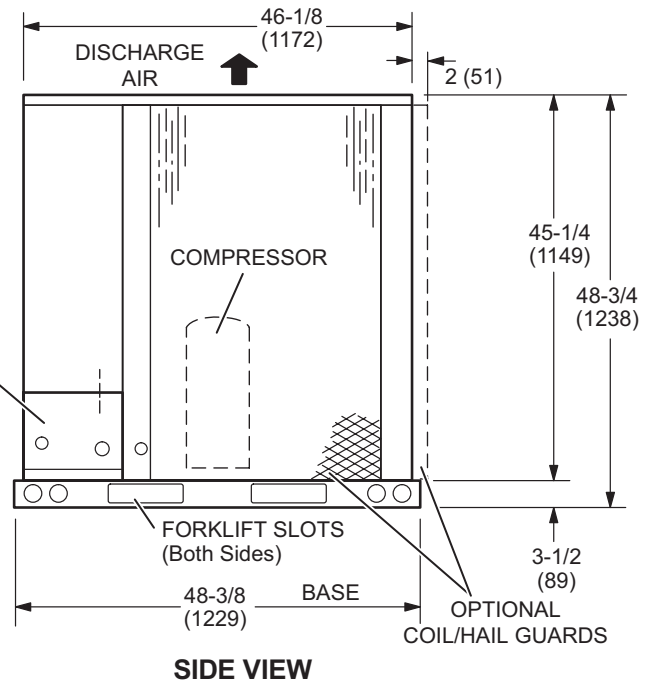
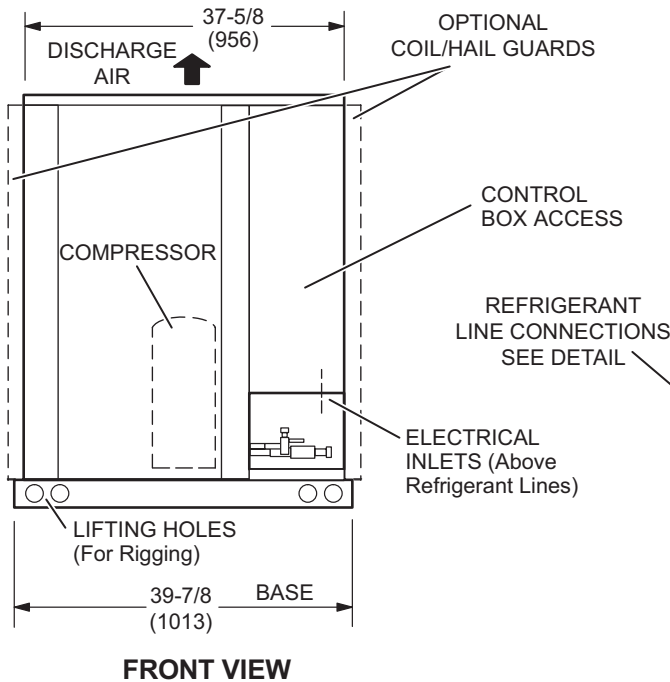
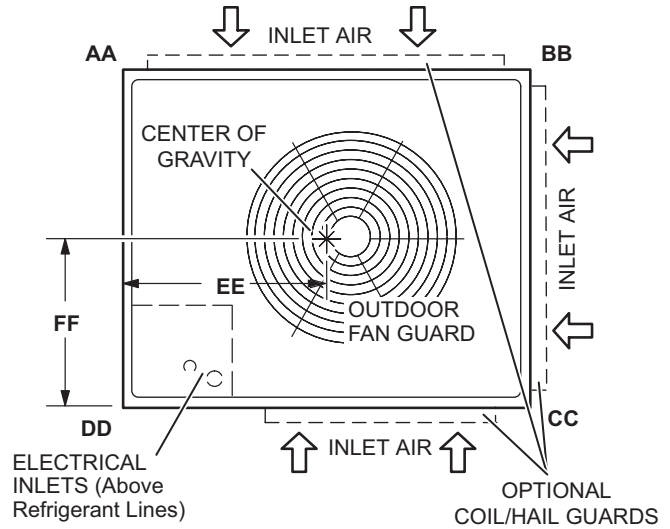
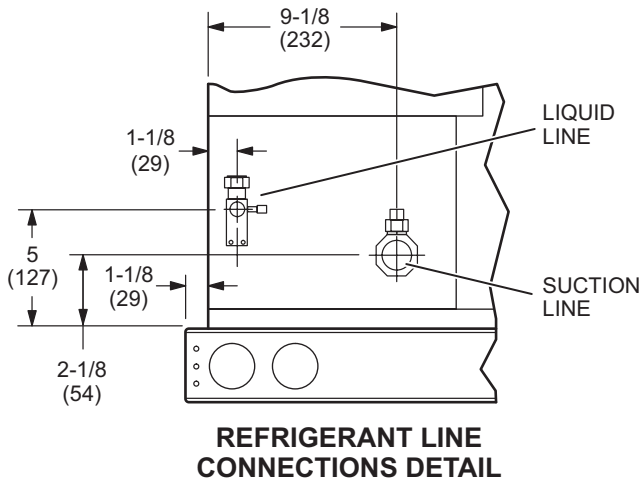

DIMENSIONS

EL120XCSS | EL120XCSD | EL150XCSD

Model No.	CORNER WEIGHTS								CENTER OF GRAVITY			
	AA		BB		CC		DD		EE		FF	
	lbs.	kg	lbs.	kg	lbs.	kg	lbs.	kg	in.	mm	in.	mm
EL120XCSS	130	59	124	56	107	49	111	50	20-1/2	521	33-1/2	851
EL120XCSD	122	55	119	54	127	58	131	59	21	533	28-1/2	724
EL150XCSD	144	66	132	60	133	60	145	66	19	483	30	762

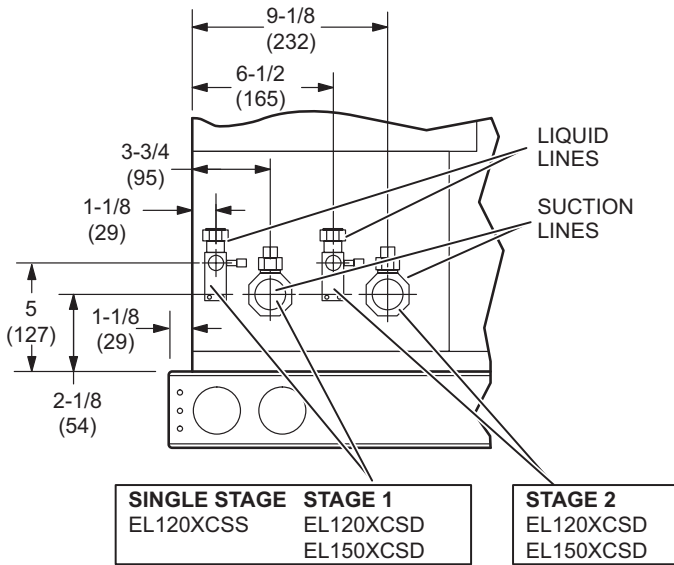

REFRIGERANT LINE CONNECTIONS DETAIL

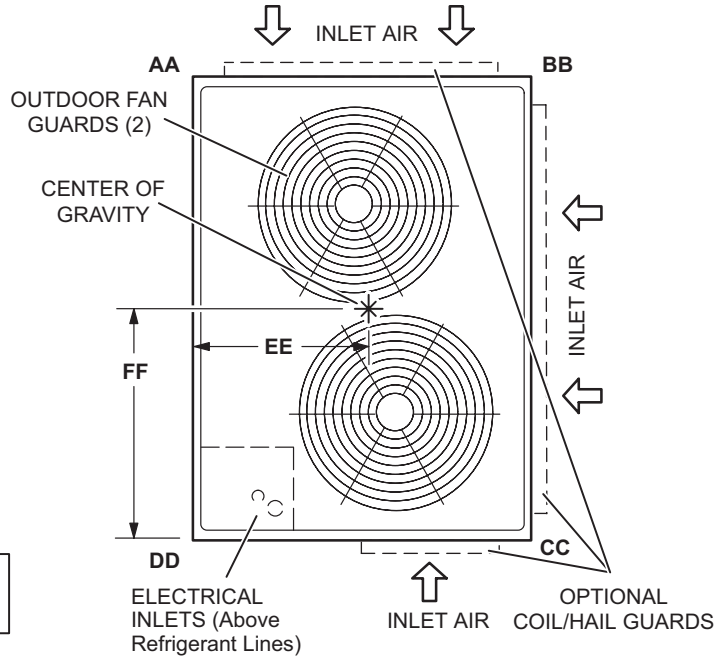

TOP VIEW

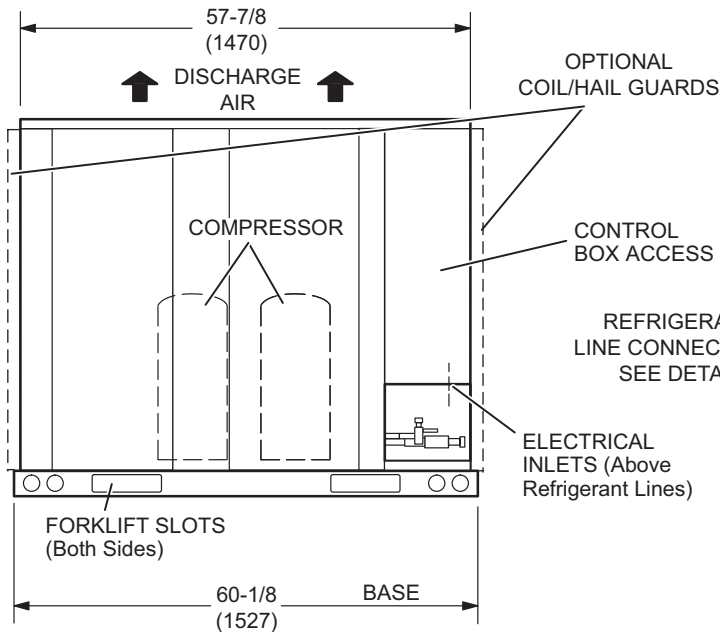

FRONT VIEW

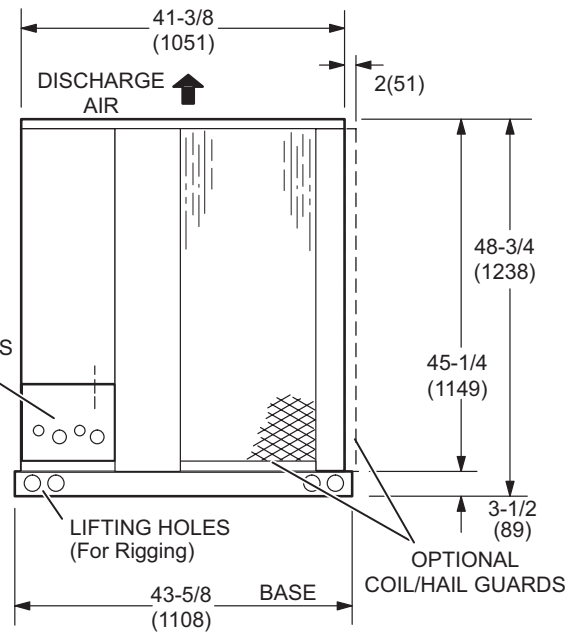

SIDE VIEW

DIMENSIONS

EL180XCSD | EL240XCSD

Model No.	CORNER WEIGHTS								CENTER OF GRAVITY			
	AA		BB		CC		DD		EE		FF	
	lbs.	kg	lbs.	kg	lbs.	kg	lbs.	kg	in.	mm	in.	mm
EL180XCSD	181	82	177	81	215	98	221	100	29	737	38	965
EL240XCSD	192	87	189	86	232	105	238	108	29	737	37-1/2	953

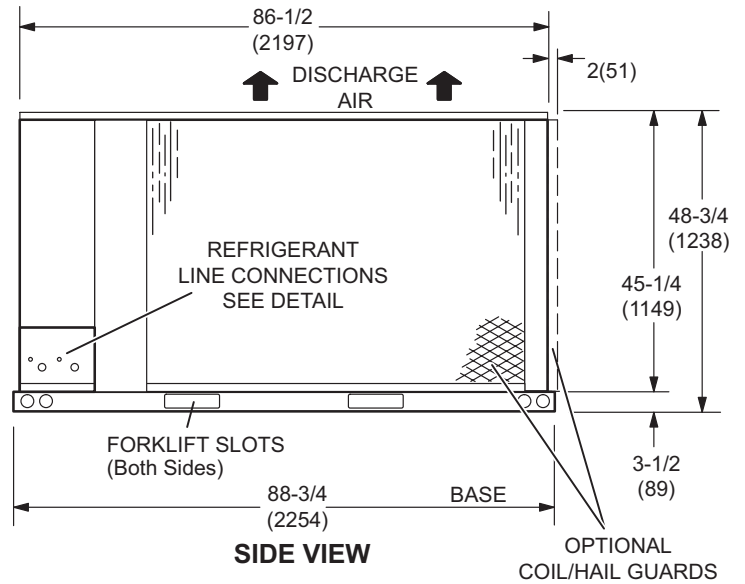
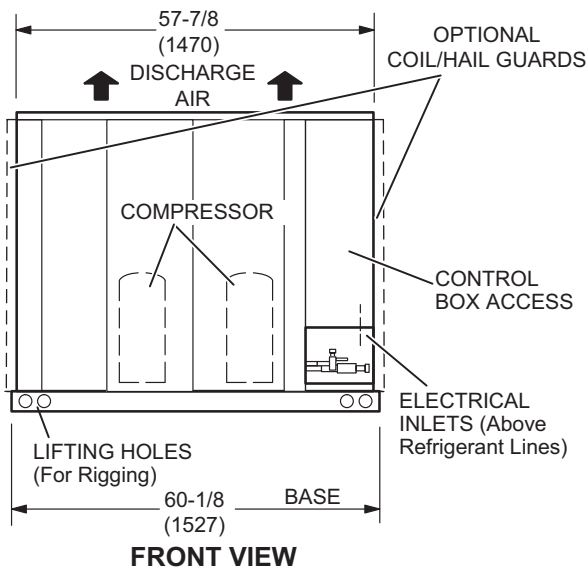
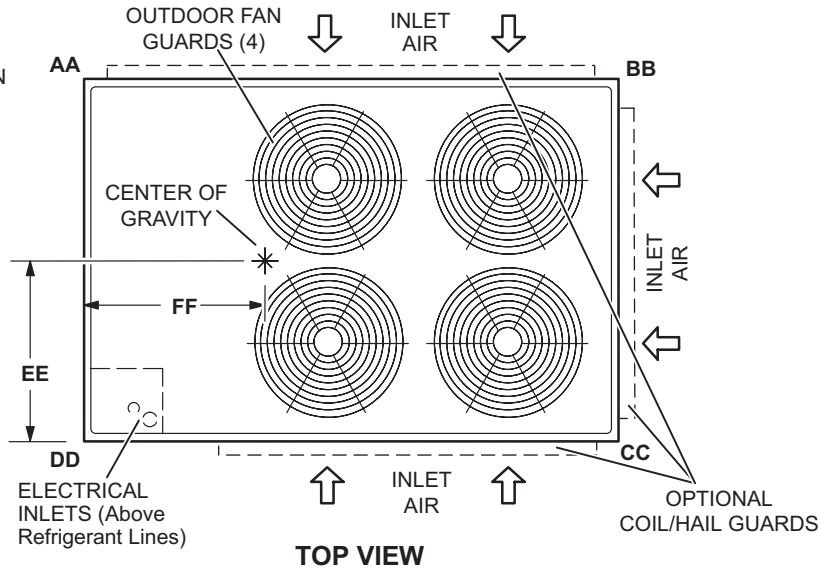
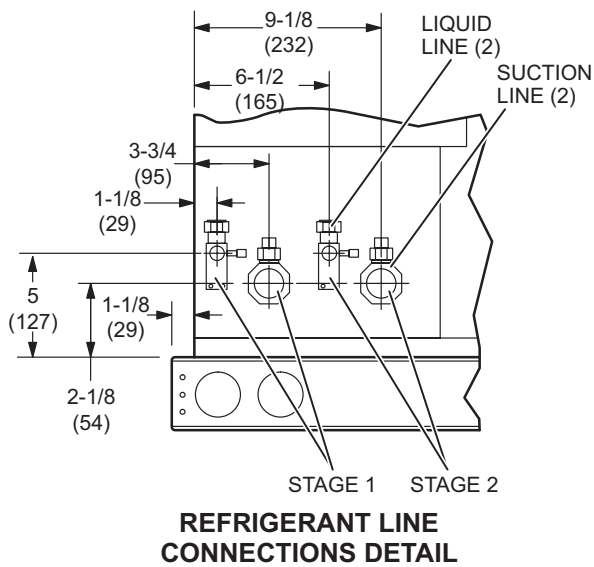

RATINGS

ONE OUTDOOR UNIT + ONE INDOOR UNIT

NOTE - For Temperatures and Capacities not shown in tables, see bulletin - Cooling Unit Rating Table Correction Factor Data in Miscellaneous Engineering Data section.

EL120XCSS + EL120XASD - 1 COMPRESSOR - PART LOAD

Entering Wet Bulb Temperature	Total Air Volume	Outdoor Air Temperature Entering Outdoor Coil																			
		65°F					75°F					85°F					95°F				
		Total Cool Cap.	Comp. Motor Input	Sensible To Total Ratio (S/T)			Total Cool Cap.	Comp. Motor Input	Sensible To Total Ratio (S/T)			Total Cool Cap.	Comp. Motor Input	Sensible To Total Ratio (S/T)			Total Cool Cap.	Comp. Motor Input	Sensible To Total Ratio (S/T)		
				Dry Bulb					Dry Bulb					Dry Bulb					Dry Bulb		
cfm	kBtuh	kW	75°F	80°F	85°F	kBtuh	kW	75°F	80°F	85°F	kBtuh	kW	75°F	80°F	85°F	kBtuh	kW	75°F	80°F	85°F	
63°F	2080	82.8	3.5	0.71	0.83	0.95	79.6	4.06	0.72	0.85	0.97	75.9	4.72	0.73	0.87	0.99	71.8	5.45	0.75	0.89	1
	2600	87.2	3.48	0.75	0.9	1	84	4.05	0.76	0.92	1	80.1	4.69	0.78	0.94	1	75.7	5.43	0.81	0.97	1
	3120	90.7	3.48	0.8	0.96	1	87.3	4.04	0.81	0.98	1	83.2	4.68	0.83	1	1	79.2	5.42	0.86	1	1
67°F	2080	88.2	3.48	0.57	0.68	0.8	84.9	4.04	0.57	0.69	0.81	81.1	4.69	0.58	0.7	0.83	76.8	5.41	0.59	0.72	0.85
	2600	92.7	3.47	0.59	0.73	0.86	89.4	4.04	0.61	0.74	0.88	85.4	4.68	0.61	0.76	0.9	80.7	5.4	0.62	0.78	0.93
	3120	95.9	3.46	0.62	0.78	0.93	92.5	4.02	0.63	0.79	0.95	88.3	4.67	0.63	0.81	0.97	83.5	5.39	0.65	0.83	0.99
71°F	2080	93.6	3.47	0.43	0.55	0.66	90.2	4.02	0.44	0.55	0.67	86.3	4.67	0.44	0.56	0.68	82.1	5.4	0.44	0.57	0.7
	2600	98.2	3.46	0.45	0.58	0.7	94.6	4.02	0.45	0.58	0.72	90.7	4.65	0.45	0.6	0.73	85.9	5.38	0.46	0.61	0.75
	3120	101.6	3.46	0.46	0.6	0.76	98	4.01	0.46	0.62	0.77	93.6	4.65	0.47	0.63	0.78	88.7	5.37	0.47	0.64	0.8

EL120XCSS + EL120XASD - 1 COMPRESSOR - FULL LOAD

Entering Wet Bulb Temperature	Total Air Volume	Outdoor Air Temperature Entering Outdoor Coil																			
		85°F					95°F					105°F					115°F				
		Total Cool Cap.	Comp. Motor Input	Sensible To Total Ratio (S/T)			Total Cool Cap.	Comp. Motor Input	Sensible To Total Ratio (S/T)			Total Cool Cap.	Comp. Motor Input	Sensible To Total Ratio (S/T)			Total Cool Cap.	Comp. Motor Input	Sensible To Total Ratio (S/T)		
				Dry Bulb					Dry Bulb					Dry Bulb					Dry Bulb		
cfm	kBtuh	kW	75°F	80°F	85°F	kBtuh	kW	75°F	80°F	85°F	kBtuh	kW	75°F	80°F	85°F	kBtuh	kW	75°F	80°F	85°F	
63°F	3200	114.4	7.43	0.73	0.87	0.99	109.4	8.24	0.74	0.88	1	104.1	9.18	0.76	0.91	1	98.2	10.25	0.78	0.93	1
	4000	119.7	7.52	0.78	0.94	1	114.5	8.33	0.8	0.96	1	108.5	9.26	0.82	0.98	1	102.7	10.34	0.84	1	1
	4800	124.1	7.6	0.83	0.99	1	118.8	8.41	0.85	1	1	113.1	9.34	0.87	1	1	107.5	10.42	0.9	1	1
67°F	3200	121.2	7.55	0.58	0.71	0.83	115.8	8.35	0.59	0.72	0.85	110.3	9.29	0.59	0.73	0.87	104.1	10.37	0.61	0.76	0.9
	4000	126.9	7.65	0.61	0.76	0.9	120.8	8.44	0.62	0.77	0.93	114.7	9.37	0.63	0.8	0.95	108.2	10.43	0.64	0.82	0.98
	4800	130.5	7.72	0.64	0.81	0.97	124.4	8.5	0.65	0.83	0.99	118.1	9.43	0.67	0.85	1	111.5	10.49	0.68	0.88	1
71°F	3200	128.4	7.68	0.44	0.56	0.68	122.7	8.48	0.44	0.57	0.7	116.7	9.4	0.45	0.58	0.71	110.3	10.46	0.45	0.6	0.73
	4000	134.1	7.78	0.45	0.6	0.74	127.9	8.57	0.46	0.61	0.75	121.2	9.48	0.46	0.62	0.77	114.4	10.55	0.47	0.64	0.8
	4800	137.9	7.85	0.47	0.63	0.79	131.5	8.62	0.47	0.64	0.81	124.6	9.54	0.48	0.66	0.83	117.4	10.58	0.49	0.68	0.86

RATINGS

ONE OUTDOOR UNIT + ONE INDOOR UNIT

NOTE - For Temperatures and Capacities not shown in tables, see bulletin - Cooling Unit Rating Table Correction Factor Data in Miscellaneous Engineering Data section.

EL120XCSD + EL120XASD - 1 COMPRESSOR - PART LOAD

Entering Wet Bulb Temperature	Total Air Volume	Outdoor Air Temperature Entering Outdoor Coil																			
		65°F					75°F					85°F					95°F				
		Total Cool Cap.	Comp. Motor Input	Sensible To Total Ratio (S/T)			Total Cool Cap.	Comp. Motor Input	Sensible To Total Ratio (S/T)			Total Cool Cap.	Comp. Motor Input	Sensible To Total Ratio (S/T)			Total Cool Cap.	Comp. Motor Input	Sensible To Total Ratio (S/T)		
				Dry Bulb					Dry Bulb					Dry Bulb					Dry Bulb		
cfm	kBtuh	kW	75°F	80°F	85°F	kBtuh	kW	75°F	80°F	85°F	kBtuh	kW	75°F	80°F	85°F	kBtuh	kW	75°F	80°F	85°F	
63°F	2080	43.9	1.87	0.69	0.82	0.93	42.2	2.17	0.71	0.83	0.95	40.1	2.50	0.72	0.85	0.97	37.7	2.87	0.74	0.87	0.99
	2600	46.4	1.86	0.74	0.87	1	44.5	2.16	0.75	0.89	1	42.3	2.49	0.77	0.91	1	39.9	2.87	0.78	0.94	1
	3120	48.4	1.85	0.78	0.93	1	46.4	2.15	0.79	0.95	1	44.1	2.49	0.81	0.97	1	41.4	2.86	0.84	1	1
67°F	2080	46.9	1.86	0.56	0.67	0.78	44.9	2.15	0.56	0.68	0.79	42.7	2.49	0.57	0.69	0.81	40.5	2.87	0.58	0.71	0.83
	2600	49.5	1.85	0.58	0.71	0.84	47.4	2.15	0.59	0.72	0.85	45.1	2.48	0.6	0.74	0.88	42.5	2.86	0.61	0.76	0.91
	3120	51.4	1.84	0.6	0.75	0.89	49.2	2.14	0.62	0.77	0.92	46.7	2.48	0.62	0.79	0.94	43.9	2.86	0.64	0.81	0.97
71°F	2080	49.7	1.85	0.43	0.54	0.64	47.7	2.14	0.43	0.54	0.65	45.5	2.48	0.44	0.55	0.66	43	2.86	0.44	0.56	0.68
	2600	52.3	1.83	0.44	0.56	0.68	50.4	2.13	0.44	0.58	0.7	47.9	2.47	0.45	0.58	0.71	45.2	2.85	0.45	0.6	0.74
	3120	54.4	1.82	0.45	0.59	0.73	52.2	2.12	0.45	0.6	0.75	49.6	2.47	0.46	0.62	0.77	46.7	2.84	0.46	0.63	0.79

EL120XCSD + EL120XASD - 2 COMPRESSORS - PART LOAD / PART LOAD

Entering Wet Bulb Temperature	Total Air Volume	Outdoor Air Temperature Entering Outdoor Coil																			
		85°F					95°F					105°F					115°F				
		Total Cool Cap.	Comp. Motor Input	Sensible To Total Ratio (S/T)			Total Cool Cap.	Comp. Motor Input	Sensible To Total Ratio (S/T)			Total Cool Cap.	Comp. Motor Input	Sensible To Total Ratio (S/T)			Total Cool Cap.	Comp. Motor Input	Sensible To Total Ratio (S/T)		
				Dry Bulb					Dry Bulb					Dry Bulb					Dry Bulb		
cfm	kBtuh	kW	75°F	80°F	85°F	kBtuh	kW	75°F	80°F	85°F	kBtuh	kW	75°F	80°F	85°F	kBtuh	kW	75°F	80°F	85°F	
63°F	2400	95.8	3.69	0.72	0.85	0.97	92	4.27	0.73	0.87	0.99	87.5	4.93	0.74	0.89	1	82.4	5.68	0.77	0.92	1
	3000	100.9	3.67	0.77	0.92	1	96.8	4.25	0.78	0.94	1	91.9	4.92	0.8	0.96	1	86.4	5.66	0.82	0.99	1
	3600	104.9	3.65	0.82	0.98	1	100.2	4.24	0.83	0.99	1	95.6	4.90	0.85	1	1	90.9	5.65	0.88	1	1
67°F	2400	102.2	3.66	0.57	0.7	0.81	97.9	4.25	0.58	0.7	0.83	93.2	4.91	0.59	0.72	0.85	87.9	5.66	0.6	0.74	0.88
	3000	107	3.64	0.6	0.74	0.88	102.7	4.23	0.61	0.76	0.9	97.7	4.89	0.62	0.78	0.93	91.9	5.64	0.63	0.8	0.96
	3600	111	3.62	0.63	0.79	0.95	106.2	4.21	0.64	0.81	0.97	100.9	4.88	0.65	0.83	0.99	94.8	5.63	0.67	0.86	1
71°F	2400	108.3	3.63	0.44	0.55	0.67	103.9	4.22	0.44	0.56	0.68	98.9	4.89	0.44	0.57	0.7	93.2	5.64	0.45	0.58	0.71
	3000	113.5	3.61	0.45	0.59	0.72	108.7	4.20	0.45	0.59	0.73	103.4	4.87	0.46	0.61	0.75	97.3	5.62	0.46	0.62	0.77
	3600	117.2	3.59	0.46	0.62	0.77	112.4	4.19	0.46	0.63	0.79	106.5	4.86	0.47	0.64	0.81	100.2	5.61	0.48	0.66	0.83

EL120XCSD + EL120XASD - 2 COMPRESSORS - FULL LOAD

Entering Wet Bulb Temperature	Total Air Volume	Outdoor Air Temperature Entering Outdoor Coil																			
		85°F					95°F					105°F					115°F				
		Total Cool Cap.	Comp. Motor Input	Sensible To Total Ratio (S/T)			Total Cool Cap.	Comp. Motor Input	Sensible To Total Ratio (S/T)			Total Cool Cap.	Comp. Motor Input	Sensible To Total Ratio (S/T)			Total Cool Cap.	Comp. Motor Input	Sensible To Total Ratio (S/T)		
				Dry Bulb					Dry Bulb					Dry Bulb					Dry Bulb		
cfm	kBtuh	kW	75°F	80°F	85°F	kBtuh	kW	75°F	80°F	85°F	kBtuh	kW	75°F	80°F	85°F	kBtuh	kW	75°F	80°F	85°F	
63°F	3200	118.1	7.24	0.74	0.87	0.99	112.9	8.08	0.75	0.89	1	107.5	9.09	0.77	0.91	1	101.6	10.23	0.79	0.94	1
	4000	124	7.31	0.79	0.94	1	118.4	8.16	0.8	0.96	1	112.5	9.15	0.82	0.98	1	106.3	10.30	0.85	1	1
	4800	128.2	7.37	0.84	1	1	122.6	8.22	0.86	1	1	117.2	9.22	0.88	1	1	111.4	10.38	0.9	1	1
67°F	3200	125.4	7.33	0.58	0.71	0.84	119.7	8.18	0.59	0.72	0.85	114	9.18	0.6	0.74	0.88	107.7	10.32	0.61	0.76	0.9
	4000	131	7.41	0.61	0.76	0.91	125	8.26	0.63	0.78	0.93	118.6	9.25	0.64	0.8	0.96	112	10.39	0.65	0.82	0.98
	4800	135.3	7.48	0.64	0.82	0.97	128.9	8.32	0.66	0.83	0.99	122.1	9.30	0.67	0.86	1	114.9	10.44	0.68	0.89	1
71°F	3200	132.6	7.44	0.44	0.57	0.69	126.7	8.29	0.44	0.57	0.7	120.5	9.28	0.45	0.58	0.72	113.6	10.42	0.45	0.6	0.73
	4000	138.4	7.52	0.46	0.6	0.74	131.9	8.37	0.46	0.61	0.76	125.2	9.35	0.46	0.62	0.78	118	10.49	0.47	0.64	0.8
	4800	142.5	7.59	0.46	0.63	0.79	135.9	8.43	0.47	0.65	0.81	128.6	9.41	0.48	0.66	0.84	121	10.55	0.49	0.68	0.86

RATINGS

ONE OUTDOOR UNIT + ONE INDOOR UNIT

NOTE - For Temperatures and Capacities not shown in tables, see bulletin - Cooling Unit Rating Table Correction Factor Data in Miscellaneous Engineering Data section.

EL150XCSD + EL150XASD - PART LOAD (1 COMPRESSOR)

Entering Wet Bulb Temperature	Total Air Volume	Outdoor Air Temperature Entering Outdoor Coil																			
		65°F					75°F					85°F					95°F				
		Total Cool Cap.	Comp. Motor Input	Sensible To Total Ratio (S/T)			Total Cool Cap.	Comp. Motor Input	Sensible To Total Ratio (S/T)			Total Cool Cap.	Comp. Motor Input	Sensible To Total Ratio (S/T)			Total Cool Cap.	Comp. Motor Input	Sensible To Total Ratio (S/T)		
				Dry Bulb					Dry Bulb					Dry Bulb					Dry Bulb		
cfm	kBtuh	kW	75°F	80°F	85°F	kBtuh	kW	75°F	80°F	85°F	kBtuh	kW	75°F	80°F	85°F	kBtuh	kW	75°F	80°F	85°F	
63°F	2640	52.2	2.29	0.71	0.83	0.95	50.5	2.65	0.72	0.84	0.97	48.3	3.06	0.73	0.86	0.98	46	3.54	0.74	0.88	1
	3300	55.2	2.28	0.75	0.89	1	53.2	2.64	0.76	0.91	1	50.9	3.05	0.78	0.93	1	48.4	3.53	0.8	0.95	1
	3960	57.5	2.27	0.79	0.95	1	55.3	2.63	0.81	0.97	1	52.9	3.05	0.83	0.99	1	50.4	3.52	0.85	1	1
67°F	2640	55.9	2.27	0.56	0.68	0.79	53.9	2.64	0.57	0.69	0.81	51.6	3.05	0.57	0.7	0.82	49.2	3.53	0.58	0.71	0.84
	3300	59	2.26	0.59	0.72	0.86	56.8	2.62	0.6	0.74	0.87	54.3	3.04	0.6	0.75	0.89	51.7	3.52	0.62	0.77	0.92
	3960	61.2	2.25	0.62	0.77	0.92	58.9	2.61	0.62	0.78	0.93	56.2	3.03	0.63	0.8	0.96	53.4	3.51	0.65	0.83	0.98
71°F	2640	59.4	2.26	0.43	0.54	0.65	57.5	2.62	0.44	0.55	0.66	55.1	3.03	0.44	0.56	0.67	52.4	3.51	0.44	0.57	0.69
	3300	62.6	2.24	0.44	0.57	0.7	60.4	2.60	0.45	0.58	0.71	57.8	3.02	0.45	0.59	0.72	55	3.50	0.45	0.6	0.74
	3960	65	2.22	0.45	0.6	0.74	62.5	2.59	0.46	0.61	0.76	59.8	3.01	0.46	0.62	0.78	56.8	3.49	0.47	0.63	0.8

EL150XCSD + EL150XASD - 2 COMPRESSORS - PART LOAD / PART LOAD

Entering Wet Bulb Temperature	Total Air Volume	Outdoor Air Temperature Entering Outdoor Coil																			
		85°F					95°F					105°F					115°F				
		Total Cool Cap.	Comp. Motor Input	Sensible To Total Ratio (S/T)			Total Cool Cap.	Comp. Motor Input	Sensible To Total Ratio (S/T)			Total Cool Cap.	Comp. Motor Input	Sensible To Total Ratio (S/T)			Total Cool Cap.	Comp. Motor Input	Sensible To Total Ratio (S/T)		
				Dry Bulb					Dry Bulb					Dry Bulb					Dry Bulb		
cfm	kBtuh	kW	75°F	80°F	85°F	kBtuh	kW	75°F	80°F	85°F	kBtuh	kW	75°F	80°F	85°F	kBtuh	kW	75°F	80°F	85°F	
63°F	3000	115.3	4.32	0.73	0.86	0.99	111.3	5.01	0.74	0.88	1	106.7	5.80	0.75	0.89	1	101.6	6.70	0.77	0.92	1
	3750	121.5	4.30	0.78	0.93	1	117	4.99	0.79	0.95	1	112	5.77	0.81	0.97	1	106.6	6.67	0.83	0.99	1
	4500	126.1	4.28	0.83	0.99	1	121.4	4.96	0.85	1	1	116.8	5.76	0.86	1	1	111.8	6.65	0.89	1	1
67°F	3000	123.2	4.29	0.58	0.7	0.83	118.9	4.98	0.58	0.72	0.84	113.9	5.77	0.59	0.73	0.86	108.2	6.66	0.6	0.74	0.88
	3750	129.3	4.27	0.61	0.75	0.9	124.6	4.95	0.61	0.77	0.92	119.3	5.75	0.63	0.78	0.94	113.2	6.65	0.64	0.81	0.96
	4500	133.8	4.24	0.64	0.81	0.96	128.6	4.93	0.65	0.82	0.98	123	5.73	0.66	0.84	1	116.8	6.63	0.67	0.86	1
71°F	3000	131	4.26	0.44	0.56	0.68	126.3	4.95	0.44	0.57	0.69	121.3	5.73	0.44	0.58	0.7	115.2	6.63	0.45	0.58	0.72
	3750	137.4	4.22	0.45	0.59	0.73	132.2	4.91	0.45	0.6	0.74	126.8	5.71	0.45	0.61	0.76	120.5	6.61	0.46	0.62	0.78
	4500	142.1	4.19	0.46	0.63	0.78	136.8	4.89	0.47	0.64	0.79	130.8	5.68	0.47	0.65	0.82	124.1	6.59	0.48	0.66	0.84

EL150XCSD + EL150XASD - 2 COMPRESSORS - FULL LOAD

Entering Wet Bulb Temperature	Total Air Volume	Outdoor Air Temperature Entering Outdoor Coil																			
		85°F					95°F					105°F					115°F				
		Total Cool Cap.	Comp. Motor Input	Sensible To Total Ratio (S/T)			Total Cool Cap.	Comp. Motor Input	Sensible To Total Ratio (S/T)			Total Cool Cap.	Comp. Motor Input	Sensible To Total Ratio (S/T)			Total Cool Cap.	Comp. Motor Input	Sensible To Total Ratio (S/T)		
				Dry Bulb					Dry Bulb					Dry Bulb					Dry Bulb		
cfm	kBtuh	kW	75°F	80°F	85°F	kBtuh	kW	75°F	80°F	85°F	kBtuh	kW	75°F	80°F	85°F	kBtuh	kW	75°F	80°F	85°F	
63°F	4000	139	8.31	0.75	0.89	1	132.3	9.45	0.76	0.91	1	125.4	10.76	0.78	0.94	1	117.7	12.29	0.81	0.97	1
	5000	145.1	8.35	0.8	0.96	1	138	9.48	0.83	0.98	1	130.6	10.80	0.85	1	1	123.7	12.32	0.87	1	1
	6000	150.2	8.39	0.86	1	1	143.8	9.53	0.88	1	1	136.7	10.85	0.91	1	1	128.9	12.35	0.94	1	1
67°F	4000	147.4	8.37	0.59	0.73	0.86	140.3	9.51	0.6	0.74	0.88	133	10.82	0.61	0.76	0.91	124.7	12.32	0.62	0.78	0.94
	5000	153.5	8.42	0.62	0.78	0.93	145.9	9.55	0.63	0.8	0.96	137.9	10.85	0.65	0.83	0.98	129	12.35	0.67	0.85	1
	6000	157.8	8.46	0.66	0.84	0.99	149.7	9.58	0.67	0.86	1	141.4	10.89	0.69	0.89	1	132.2	12.38	0.71	0.92	1
71°F	4000	155.7	8.44	0.44	0.58	0.7	148.3	9.58	0.44	0.59	0.72	140.5	10.87	0.45	0.6	0.74	131.9	12.38	0.46	0.61	0.76
	5000	162	8.49	0.46	0.61	0.76	154	9.63	0.46	0.62	0.78	145.6	10.92	0.46	0.64	0.8	136.6	12.42	0.47	0.66	0.83
	6000	166.4	8.54	0.47	0.65	0.82	158.1	9.67	0.48	0.66	0.84	149.5	10.96	0.48	0.68	0.87	139.8	12.44	0.49	0.7	0.9

RATINGS

ONE OUTDOOR UNIT + ONE INDOOR UNIT

NOTE - For Temperatures and Capacities not shown in tables, see bulletin - Cooling Unit Rating Table Correction Factor Data in Miscellaneous Engineering Data section.

EL150XCSD + EL180XASD - 1 COMPRESSOR - PART LOAD

Entering Wet Bulb Temperature	Total Air Volume	Outdoor Air Temperature Entering Outdoor Coil																				
		65°F						75°F					85°F					95°F				
		Total Cool Cap.	Comp. Motor Input	Sensible To Total Ratio (S/T)			Total Cool Cap.	Comp. Motor Input	Sensible To Total Ratio (S/T)			Total Cool Cap.	Comp. Motor Input	Sensible To Total Ratio (S/T)			Total Cool Cap.	Comp. Motor Input	Sensible To Total Ratio (S/T)			
				Dry Bulb					Dry Bulb					Dry Bulb					Dry Bulb			
cfm	kBtuh	kW	75°F	80°F	85°F	kBtuh	kW	75°F	80°F	85°F	kBtuh	kW	75°F	80°F	85°F	kBtuh	kW	75°F	80°F	85°F		
63°F	2640	52.3	2.29	0.7	0.82	0.94	50.6	2.65	0.71	0.84	0.96	48.5	3.06	0.72	0.85	0.98	46.2	3.54	0.74	0.87	1	
	3300	55.5	2.28	0.74	0.88	1	53.5	2.64	0.75	0.9	1	51.2	3.05	0.77	0.92	1	48.6	3.53	0.79	0.94	1	
	3960	57.7	2.26	0.78	0.94	1	55.6	2.63	0.8	0.96	1	53.1	3.05	0.81	0.98	1	50.5	3.52	0.84	1	1	
67°F	2640	55.7	2.28	0.56	0.68	0.79	53.8	2.64	0.57	0.69	0.8	51.7	3.06	0.58	0.7	0.82	49.2	3.53	0.58	0.71	0.83	
	3300	59	2.26	0.59	0.72	0.85	56.8	2.62	0.59	0.73	0.86	54.5	3.03	0.6	0.74	0.88	51.8	3.52	0.61	0.76	0.9	
	3960	61.4	2.24	0.61	0.76	0.9	59.1	2.61	0.62	0.77	0.92	56.7	3.03	0.63	0.79	0.95	53.7	3.51	0.64	0.81	0.97	
71°F	2640	59	2.26	0.44	0.54	0.65	56.8	2.62	0.44	0.55	0.66	54.6	3.04	0.44	0.56	0.67	52.1	3.51	0.44	0.57	0.68	
	3300	62.4	2.24	0.45	0.57	0.69	60.2	2.60	0.45	0.58	0.7	57.7	3.02	0.45	0.59	0.72	55	3.50	0.46	0.6	0.73	
	3960	65	2.22	0.45	0.6	0.73	62.6	2.59	0.45	0.6	0.75	60	3.01	0.45	0.62	0.76	57.1	3.49	0.46	0.63	0.78	

EL150XCSD + EL180XASD - 2 COMPRESSORS - PART LOAD / PART LOAD

Entering Wet Bulb Temperature	Total Air Volume	Outdoor Air Temperature Entering Outdoor Coil																				
		85°F						95°F					105°F					115°F				
		Total Cool Cap.	Comp. Motor Input	Sensible To Total Ratio (S/T)			Total Cool Cap.	Comp. Motor Input	Sensible To Total Ratio (S/T)			Total Cool Cap.	Comp. Motor Input	Sensible To Total Ratio (S/T)			Total Cool Cap.	Comp. Motor Input	Sensible To Total Ratio (S/T)			
				Dry Bulb					Dry Bulb					Dry Bulb					Dry Bulb			
cfm	kBtuh	kW	75°F	80°F	85°F	kBtuh	kW	75°F	80°F	85°F	kBtuh	kW	75°F	80°F	85°F	kBtuh	kW	75°F	80°F	85°F		
63°F	3000	115.2	4.33	0.72	0.85	0.98	111.1	5.01	0.73	0.87	0.99	106.6	5.80	0.75	0.89	1	101.4	6.70	0.76	0.91	1	
	3750	121.3	4.30	0.77	0.92	1	116.9	4.99	0.78	0.94	1	112	5.78	0.8	0.96	1	106.5	6.68	0.82	0.98	1	
	4500	126	4.28	0.82	0.98	1	121.4	4.97	0.83	0.99	1	116.3	5.75	0.85	1	1	111.4	6.66	0.87	1	1	
67°F	3000	122.4	4.29	0.57	0.7	0.82	118.1	4.98	0.58	0.71	0.83	113.5	5.77	0.59	0.72	0.85	108	6.66	0.6	0.74	0.87	
	3750	128.9	4.26	0.6	0.74	0.88	124.3	4.96	0.61	0.76	0.9	119.2	5.75	0.62	0.77	0.92	113.3	6.65	0.63	0.79	0.95	
	4500	133.8	4.24	0.63	0.79	0.94	128.8	4.93	0.64	0.81	0.96	123	5.73	0.65	0.82	0.98	117	6.63	0.67	0.85	1	
71°F	3000	129.6	4.26	0.43	0.56	0.67	125	4.95	0.44	0.56	0.68	120.3	5.74	0.43	0.57	0.7	114.6	6.64	0.43	0.58	0.71	
	3750	136.5	4.22	0.45	0.58	0.72	131.5	4.92	0.44	0.59	0.73	126.1	5.71	0.44	0.6	0.75	120	6.61	0.46	0.62	0.77	
	4500	141.7	4.20	0.44	0.62	0.77	136.5	4.89	0.45	0.62	0.78	130.4	5.68	0.46	0.64	0.8	124	6.59	0.47	0.65	0.82	

EL150XCSD + EL180XASD - 2 COMPRESSORS - FULL LOAD

Entering Wet Bulb Temperature	Total Air Volume	Outdoor Air Temperature Entering Outdoor Coil																				
		85°F						95°F					105°F					115°F				
		Total Cool Cap.	Comp. Motor Input	Sensible To Total Ratio (S/T)			Total Cool Cap.	Comp. Motor Input	Sensible To Total Ratio (S/T)			Total Cool Cap.	Comp. Motor Input	Sensible To Total Ratio (S/T)			Total Cool Cap.	Comp. Motor Input	Sensible To Total Ratio (S/T)			
				Dry Bulb					Dry Bulb					Dry Bulb					Dry Bulb			
cfm	kBtuh	kW	75°F	80°F	85°F	kBtuh	kW	75°F	80°F	85°F	kBtuh	kW	75°F	80°F	85°F	kBtuh	kW	75°F	80°F	85°F		
63°F	4000	139.6	8.31	0.74	0.88	1	133	9.45	0.75	0.9	1	126.1	10.77	0.77	0.92	1	118.3	12.28	0.79	0.95	1	
	5000	145.7	8.36	0.79	0.95	1	138.8	9.50	0.81	0.97	1	131.5	10.81	0.83	0.99	1	123.7	12.30	0.86	1	1	
	6000	150.8	8.40	0.84	1	1	143.9	9.54	0.86	1	1	136.9	10.85	0.89	1	1	129.5	12.36	0.92	1	1	
67°F	4000	147.6	8.37	0.59	0.72	0.84	140.8	9.51	0.59	0.73	0.86	133.5	10.82	0.6	0.75	0.89	125.2	12.32	0.62	0.77	0.92	
	5000	154	8.42	0.62	0.77	0.92	146.6	9.55	0.63	0.79	0.94	138.9	10.86	0.64	0.81	0.97	130.3	12.36	0.66	0.83	0.99	
	6000	158.7	8.47	0.65	0.82	0.97	150.9	9.60	0.66	0.84	1	142.8	10.90	0.67	0.87	1	133.4	12.39	0.7	0.9	1	
71°F	4000	155.2	8.43	0.44	0.57	0.69	148.2	9.57	0.44	0.58	0.71	140.5	10.88	0.44	0.59	0.73	132.1	12.38	0.45	0.6	0.75	
	5000	162.2	8.50	0.45	0.6	0.74	154.3	9.63	0.45	0.61	0.76	146.1	10.93	0.47	0.63	0.79	137.2	12.43	0.47	0.65	0.81	
	6000	167.3	8.55	0.45	0.63	0.8	159.2	9.68	0.47	0.65	0.82	150.5	10.97	0.48	0.67	0.84	140.7	12.45	0.49	0.69	0.88	

RATINGS

ONE OUTDOOR UNIT + ONE INDOOR UNIT

NOTE - For Temperatures and Capacities not shown in tables, see bulletin - Cooling Unit Rating Table Correction Factor Data in Miscellaneous Engineering Data section.

EL180XCSD + EL180XASD - 1 COMPRESSOR - PART LOAD

Entering Wet Bulb Temperature	Total Air Volume	Outdoor Air Temperature Entering Outdoor Coil																			
		65°F					75°F					85°F					95°F				
		Total Cool Cap.	Comp. Motor Input	Sensible To Total Ratio (S/T)			Total Cool Cap.	Comp. Motor Input	Sensible To Total Ratio (S/T)			Total Cool Cap.	Comp. Motor Input	Sensible To Total Ratio (S/T)			Total Cool Cap.	Comp. Motor Input	Sensible To Total Ratio (S/T)		
				Dry Bulb					Dry Bulb					Dry Bulb					Dry Bulb		
cfm	kBtuh	kW	75°F	80°F	85°F	kBtuh	kW	75°F	80°F	85°F	kBtuh	kW	75°F	80°F	85°F	kBtuh	kW	75°F	80°F	85°F	
63°F	3200	67.0	2.60	0.7	0.82	0.94	63.8	3.06	0.71	0.84	0.96	60.4	3.57	0.73	0.86	0.98	56.7	4.14	0.75	0.89	1
	4000	71.0	2.57	0.74	0.88	1	67.5	3.03	0.75	0.9	1	63.8	3.54	0.77	0.92	1	59.8	4.12	0.8	0.96	1
	4800	73.9	2.54	0.78	0.93	1	70.2	3.01	0.8	0.96	1	66.3	3.53	0.82	0.98	1	62.2	4.10	0.85	1	1
67°F	3200	71.4	2.56	0.56	0.67	0.78	68.1	3.02	0.57	0.69	0.8	64.5	3.54	0.58	0.7	0.82	60.7	4.11	0.59	0.72	0.85
	4000	75.6	2.53	0.58	0.71	0.84	72.0	3.00	0.59	0.73	0.86	68.2	3.51	0.6	0.75	0.89	64.0	4.09	0.62	0.77	0.92
	4800	78.7	2.50	0.61	0.75	0.89	74.9	2.97	0.62	0.77	0.92	70.8	3.49	0.63	0.79	0.95	66.4	4.07	0.65	0.82	0.98
71°F	3200	75.5	2.53	0.44	0.54	0.65	72.1	2.99	0.44	0.55	0.66	68.5	3.51	0.44	0.56	0.67	64.5	4.08	0.44	0.57	0.69
	4000	79.9	2.49	0.44	0.57	0.69	76.4	2.96	0.44	0.57	0.7	72.4	3.48	0.45	0.59	0.72	68.0	4.06	0.45	0.6	0.74
	4800	83.3	2.46	0.46	0.59	0.73	79.6	2.93	0.45	0.6	0.74	75.2	3.46	0.46	0.62	0.77	70.7	4.04	0.47	0.63	0.79

EL180XCSD + EL180XASD - 2 COMPRESSORS - PART LOAD / PART LOAD

Entering Wet Bulb Temperature	Total Air Volume	Outdoor Air Temperature Entering Outdoor Coil																			
		85°F					95°F					105°F					115°F				
		Total Cool Cap.	Comp. Motor Input	Sensible To Total Ratio (S/T)			Total Cool Cap.	Comp. Motor Input	Sensible To Total Ratio (S/T)			Total Cool Cap.	Comp. Motor Input	Sensible To Total Ratio (S/T)			Total Cool Cap.	Comp. Motor Input	Sensible To Total Ratio (S/T)		
				Dry Bulb					Dry Bulb					Dry Bulb					Dry Bulb		
cfm	kBtuh	kW	75°F	80°F	85°F	kBtuh	kW	75°F	80°F	85°F	kBtuh	kW	75°F	80°F	85°F	kBtuh	kW	75°F	80°F	85°F	
63°F	3600	139.0	5.38	0.71	0.84	0.96	132.8	6.31	0.73	0.86	0.98	125.8	7.37	0.74	0.88	1	118.2	8.61	0.76	0.91	1
	4500	146.4	5.31	0.75	0.9	1	139.9	6.25	0.77	0.92	1	132.5	7.32	0.79	0.95	1	124.4	8.52	0.82	0.98	1
	5400	152.6	5.25	0.79	0.95	1	145.5	6.20	0.81	0.97	1	137.9	7.25	0.84	1	1	130.4	8.47	0.87	1	1
67°F	3600	147.7	5.30	0.56	0.69	0.8	141.4	6.24	0.57	0.7	0.82	134.5	7.30	0.59	0.72	0.84	126.7	8.52	0.6	0.73	0.87
	4500	155.0	5.21	0.59	0.73	0.86	148.9	6.15	0.6	0.75	0.88	141.4	7.23	0.61	0.76	0.91	133.2	8.43	0.63	0.79	0.94
	5400	160.7	5.15	0.62	0.77	0.91	154.0	6.10	0.63	0.79	0.94	146.5	7.17	0.64	0.81	0.97	137.9	8.39	0.66	0.84	1
71°F	3600	156.0	5.19	0.42	0.55	0.66	150.6	6.14	0.43	0.55	0.67	142.8	7.22	0.44	0.57	0.69	134.8	8.41	0.45	0.58	0.71
	4500	162.8	5.14	0.45	0.57	0.7	157.5	6.07	0.44	0.58	0.72	150.4	7.15	0.44	0.6	0.74	141.7	8.35	0.45	0.61	0.76
	5400	168.0	5.08	0.43	0.61	0.74	162.4	6.03	0.45	0.62	0.76	155.4	7.09	0.45	0.63	0.78	146.8	8.31	0.47	0.65	0.81

EL180XCSD + EL180XASD - 2 COMPRESSORS - FULL LOAD

Entering Wet Bulb Temperature	Total Air Volume	Outdoor Air Temperature Entering Outdoor Coil																			
		85°F					95°F					105°F					115°F				
		Total Cool Cap.	Comp. Motor Input	Sensible To Total Ratio (S/T)			Total Cool Cap.	Comp. Motor Input	Sensible To Total Ratio (S/T)			Total Cool Cap.	Comp. Motor Input	Sensible To Total Ratio (S/T)			Total Cool Cap.	Comp. Motor Input	Sensible To Total Ratio (S/T)		
				Dry Bulb					Dry Bulb					Dry Bulb					Dry Bulb		
cfm	kBtuh	kW	75°F	80°F	85°F	kBtuh	kW	75°F	80°F	85°F	kBtuh	kW	75°F	80°F	85°F	kBtuh	kW	75°F	80°F	85°F	
63°F	4800	176.4	11.18	0.72	0.85	0.97	167.3	12.56	0.73	0.87	0.99	157.6	14.14	0.75	0.89	1	147.1	15.95	0.77	0.93	1
	6000	185.5	11.25	0.76	0.91	1	175.7	12.63	0.78	0.93	1	165.1	14.19	0.8	0.96	1	153.8	16.00	0.83	0.99	1
	7200	192.0	11.32	0.8	0.96	1	181.9	12.67	0.83	0.98	1	171.4	14.26	0.85	1	1	160.9	16.05	0.89	1	1
67°F	4800	187.1	11.26	0.57	0.69	0.81	178.0	12.66	0.58	0.71	0.83	168.0	14.22	0.59	0.73	0.86	157.1	16.03	0.6	0.75	0.89
	6000	196.7	11.35	0.6	0.74	0.87	186.8	12.73	0.61	0.76	0.9	175.8	14.29	0.62	0.78	0.93	164.0	16.09	0.64	0.81	0.96
	7200	203.6	11.42	0.62	0.78	0.93	193.2	12.79	0.64	0.8	0.95	181.7	14.35	0.65	0.83	0.98	168.9	16.12	0.67	0.86	1
71°F	4800	197.7	11.36	0.43	0.55	0.67	187.9	12.73	0.45	0.57	0.68	177.9	14.31	0.45	0.57	0.7	166.6	16.11	0.45	0.59	0.72
	6000	207.9	11.47	0.43	0.58	0.71	197.2	12.83	0.45	0.59	0.73	186.3	14.39	0.46	0.61	0.75	174.0	16.17	0.47	0.62	0.78
	7200	215.2	11.55	0.44	0.61	0.75	204.0	12.90	0.46	0.62	0.78	192.2	14.43	0.47	0.64	0.8	179.4	16.24	0.48	0.66	0.84

RATINGS

ONE OUTDOOR UNIT + ONE INDOOR UNIT

NOTE - For Temperatures and Capacities not shown in tables, see bulletin - Cooling Unit Rating Table Correction Factor Data in Miscellaneous Engineering Data section.

EL180XCSD + EL240XASD - 1 COMPRESSOR - PART LOAD

Entering Wet Bulb Temperature	Total Air Volume	Outdoor Air Temperature Entering Outdoor Coil																				
		65°F						75°F					85°F					95°F				
		Total Cool Cap.	Comp. Motor Input	Sensible To Total Ratio (S/T)			Total Cool Cap.	Comp. Motor Input	Sensible To Total Ratio (S/T)			Total Cool Cap.	Comp. Motor Input	Sensible To Total Ratio (S/T)			Total Cool Cap.	Comp. Motor Input	Sensible To Total Ratio (S/T)			
				Dry Bulb					Dry Bulb					Dry Bulb					Dry Bulb			
cfm	kBtuh	kW	75°F	80°F	85°F	kBtuh	kW	75°F	80°F	85°F	kBtuh	kW	75°F	80°F	85°F	kBtuh	kW	75°F	80°F	85°F		
63°F	3200	69.5	2.58	0.7	0.82	0.94	66.2	3.04	0.71	0.84	0.96	62.6	3.55	0.73	0.86	0.99	58.7	4.13	0.74	0.89	1	
	4000	73.8	2.55	0.74	0.88	1	70.0	3.01	0.76	0.9	1	66.2	3.52	0.77	0.93	1	62.0	4.11	0.8	0.96	1	
	4800	76.6	2.52	0.78	0.94	1	72.9	2.99	0.8	0.96	1	68.8	3.50	0.82	0.99	1	64.9	4.08	0.85	1	1	
67°F	3200	74.5	2.54	0.56	0.67	0.78	70.9	3.00	0.57	0.68	0.8	67.1	3.52	0.57	0.7	0.82	63.2	4.09	0.58	0.72	0.85	
	4000	78.9	2.50	0.58	0.71	0.84	75.0	2.97	0.59	0.73	0.86	71.0	3.49	0.6	0.75	0.89	66.6	4.07	0.61	0.77	0.92	
	4800	81.9	2.48	0.61	0.75	0.9	78.0	2.95	0.62	0.77	0.93	73.6	3.47	0.63	0.8	0.96	69.0	4.05	0.65	0.82	0.99	
71°F	3200	79.2	2.50	0.43	0.54	0.65	76.0	2.96	0.43	0.54	0.66	71.7	3.48	0.44	0.56	0.67	67.7	4.06	0.44	0.57	0.69	
	4000	83.7	2.46	0.44	0.56	0.68	80.1	2.93	0.44	0.57	0.7	75.7	3.45	0.45	0.58	0.72	71.2	4.04	0.45	0.6	0.74	
	4800	87.1	2.43	0.45	0.59	0.73	83.2	2.90	0.45	0.6	0.74	78.7	3.43	0.46	0.62	0.77	73.7	4.01	0.47	0.63	0.8	

EL180XCSS + EL240XASD - 2 COMPRESSORS - PART LOAD / PART LOAD

Entering Wet Bulb Temperature	Total Air Volume	Outdoor Air Temperature Entering Outdoor Coil																				
		85°F						95°F					105°F					115°F				
		Total Cool Cap.	Comp. Motor Input	Sensible To Total Ratio (S/T)			Total Cool Cap.	Comp. Motor Input	Sensible To Total Ratio (S/T)			Total Cool Cap.	Comp. Motor Input	Sensible To Total Ratio (S/T)			Total Cool Cap.	Comp. Motor Input	Sensible To Total Ratio (S/T)			
				Dry Bulb					Dry Bulb					Dry Bulb					Dry Bulb			
cfm	kBtuh	kW	75°F	80°F	85°F	kBtuh	kW	75°F	80°F	85°F	kBtuh	kW	75°F	80°F	85°F	kBtuh	kW	75°F	80°F	85°F		
63°F	3600	145.2	5.32	0.71	0.84	0.96	138.5	6.27	0.73	0.86	0.99	131.4	7.34	0.74	0.88	1	123.4	8.54	0.76	0.92	1	
	4500	153.4	5.23	0.76	0.9	1	146.3	6.19	0.78	0.93	1	138.4	7.26	0.8	0.96	1	129.9	8.48	0.82	0.99	1	
	5400	159.4	5.17	0.8	0.96	1	151.9	6.13	0.82	0.99	1	144.3	7.20	0.85	1	1	136.9	8.42	0.88	1	1	
67°F	3600	154.6	5.22	0.56	0.68	0.8	148.2	6.17	0.57	0.7	0.82	141.1	7.25	0.59	0.72	0.84	132.9	8.45	0.6	0.74	0.87	
	4500	163.1	5.14	0.59	0.73	0.86	156.1	6.09	0.61	0.75	0.89	148.3	7.17	0.61	0.77	0.92	139.5	8.38	0.63	0.8	0.95	
	5400	169.0	5.07	0.61	0.77	0.92	161.5	6.05	0.63	0.79	0.95	153.0	7.10	0.64	0.82	0.98	144.0	8.32	0.66	0.85	1	
71°F	3600	164.3	5.12	0.44	0.56	0.66	158.0	6.07	0.44	0.55	0.67	150.1	7.14	0.44	0.57	0.69	142.0	8.36	0.45	0.58	0.71	
	4500	171.4	5.05	0.42	0.58	0.71	165.3	6.01	0.43	0.59	0.72	158.1	7.08	0.45	0.6	0.74	148.9	8.28	0.46	0.61	0.77	
	5400	176.4	4.99	0.42	0.59	0.75	170.4	5.95	0.45	0.61	0.77	162.8	7.02	0.45	0.63	0.79	153.7	8.24	0.47	0.65	0.82	

EL180XCSS + EL240XASD - 2 COMPRESSORS - FULL LOAD

Entering Wet Bulb Temperature	Total Air Volume	Outdoor Air Temperature Entering Outdoor Coil																				
		85°F						95°F					105°F					115°F				
		Total Cool Cap.	Comp. Motor Input	Sensible To Total Ratio (S/T)			Total Cool Cap.	Comp. Motor Input	Sensible To Total Ratio (S/T)			Total Cool Cap.	Comp. Motor Input	Sensible To Total Ratio (S/T)			Total Cool Cap.	Comp. Motor Input	Sensible To Total Ratio (S/T)			
				Dry Bulb					Dry Bulb					Dry Bulb					Dry Bulb			
cfm	kBtuh	kW	75°F	80°F	85°F	kBtuh	kW	75°F	80°F	85°F	kBtuh	kW	75°F	80°F	85°F	kBtuh	kW	75°F	80°F	85°F		
63°F	4800	187.8	11.28	0.72	0.85	0.97	178.2	12.65	0.73	0.87	0.99	167.5	14.21	0.75	0.89	1	156.3	15.99	0.77	0.93	1	
	6000	197.2	11.36	0.76	0.91	1	186.9	12.73	0.78	0.94	1	175.5	14.28	0.8	0.97	1	163.7	16.06	0.83	1	1	
	7200	204.4	11.43	0.8	0.97	1	193.5	12.79	0.83	0.99	1	183.3	14.37	0.86	1	1	172.4	16.16	0.89	1	1	
67°F	4800	199.6	11.38	0.57	0.69	0.81	190.0	12.76	0.58	0.7	0.83	179.1	14.32	0.58	0.72	0.86	167.5	16.11	0.6	0.75	0.89	
	6000	209.8	11.49	0.59	0.73	0.87	199.5	12.85	0.61	0.76	0.9	187.6	14.41	0.62	0.78	0.93	174.6	16.15	0.64	0.8	0.97	
	7200	217.2	11.56	0.62	0.78	0.93	206.1	12.92	0.64	0.81	0.97	193.9	14.48	0.65	0.84	0.99	180.2	16.23	0.67	0.87	1	
71°F	4800	212.4	11.51	0.43	0.55	0.66	201.4	12.86	0.44	0.56	0.68	190.6	14.44	0.44	0.57	0.7	178.4	16.23	0.44	0.58	0.72	
	6000	222.5	11.62	0.43	0.58	0.71	211.4	12.98	0.44	0.59	0.73	199.1	14.53	0.46	0.61	0.75	186.0	16.28	0.46	0.62	0.78	
	7200	230.3	11.71	0.45	0.61	0.76	218.4	13.05	0.45	0.63	0.78	205.6	14.60	0.47	0.64	0.81	192.0	16.35	0.48	0.66	0.84	

RATINGS

ONE OUTDOOR UNIT + ONE INDOOR UNIT

NOTE - For Temperatures and Capacities not shown in tables, see bulletin - Cooling Unit Rating Table Correction Factor Data in Miscellaneous Engineering Data section.

EL240XCSD + EL240XASD - 1 COMPRESSOR - PART LOAD

Entering Wet Bulb Temperature	Total Air Volume	Outdoor Air Temperature Entering Outdoor Coil																			
		65°F					75°F					85°F					95°F				
		Total Cool Cap.	Comp. Motor Input	Sensible To Total Ratio (S/T)			Total Cool Cap.	Comp. Motor Input	Sensible To Total Ratio (S/T)			Total Cool Cap.	Comp. Motor Input	Sensible To Total Ratio (S/T)			Total Cool Cap.	Comp. Motor Input	Sensible To Total Ratio (S/T)		
				Dry Bulb					Dry Bulb					Dry Bulb					Dry Bulb		
cfm	kBtuh	kW	75°F	80°F	85°F	kBtuh	kW	75°F	80°F	85°F	kBtuh	kW	75°F	80°F	85°F	kBtuh	kW	75°F	80°F	85°F	
63°F	4240	85	3.41	0.72	0.84	0.96	81.5	3.97	0.72	0.86	0.98	77.4	4.59	0.74	0.88	1	72.8	5.29	0.76	0.9	1
	5300	89.4	3.4	0.76	0.9	1	85.7	3.95	0.77	0.93	1	81.4	4.58	0.79	0.95	1	76.4	5.28	0.82	0.98	1
	6360	92.7	3.4	0.81	0.97	1	88.8	3.95	0.82	0.99	1	84.4	4.57	0.84	1	1	80.2	5.27	0.87	1	1
67°F	4240	90.5	3.4	0.57	0.69	0.81	86.9	3.95	0.57	0.7	0.82	82.8	4.57	0.58	0.71	0.84	78.1	5.27	0.59	0.73	0.87
	5300	95.2	3.39	0.6	0.73	0.87	91.4	3.94	0.6	0.75	0.89	86.8	4.56	0.61	0.76	0.92	81.9	5.26	0.63	0.79	0.94
	6360	98.5	3.39	0.62	0.78	0.93	94.6	3.93	0.64	0.8	0.96	89.9	4.55	0.65	0.82	0.98	84.6	5.25	0.66	0.85	1
71°F	4240	95.7	3.39	0.43	0.55	0.66	92.3	3.94	0.44	0.57	0.67	88	4.56	0.44	0.56	0.68	83.2	5.25	0.44	0.57	0.7
	5300	100.7	3.39	0.45	0.58	0.71	96.9	3.93	0.45	0.59	0.72	92.3	4.55	0.45	0.6	0.74	87.4	5.24	0.46	0.61	0.76
	6360	103.9	3.39	0.46	0.61	0.75	100	3.92	0.46	0.62	0.78	95.5	4.54	0.47	0.64	0.79	90.1	5.24	0.47	0.65	0.82

EL240XCSD + EL240XASD - 2 COMPRESSORS - PART LOAD / PART LOAD

Entering Wet Bulb Temperature	Total Air Volume	Outdoor Air Temperature Entering Outdoor Coil																			
		85°F					95°F					105°F					115°F				
		Total Cool Cap.	Comp. Motor Input	Sensible To Total Ratio (S/T)			Total Cool Cap.	Comp. Motor Input	Sensible To Total Ratio (S/T)			Total Cool Cap.	Comp. Motor Input	Sensible To Total Ratio (S/T)			Total Cool Cap.	Comp. Motor Input	Sensible To Total Ratio (S/T)		
				Dry Bulb					Dry Bulb					Dry Bulb					Dry Bulb		
cfm	kBtuh	kW	75°F	80°F	85°F	kBtuh	kW	75°F	80°F	85°F	kBtuh	kW	75°F	80°F	85°F	kBtuh	kW	75°F	80°F	85°F	
63°F	4800	177	6.82	0.73	0.87	1	170	7.93	0.75	0.89	1	161.4	9.18	0.77	0.92	1	151.9	10.58	0.79	0.95	1
	6000	185.6	6.81	0.78	0.94	1	178.1	7.91	0.81	0.97	1	169.1	9.15	0.83	0.99	1	159.7	10.56	0.85	1	1
	7200	191.9	6.79	0.84	1	1	184.9	7.89	0.86	1	1	177.1	9.13	0.88	1	1	168.5	10.53	0.91	1	1
67°F	4800	188.4	6.8	0.58	0.71	0.84	181.4	7.9	0.59	0.72	0.85	172.7	9.14	0.6	0.74	0.88	162.6	10.54	0.61	0.76	0.91
	6000	197	6.79	0.61	0.76	0.91	189.7	7.88	0.62	0.78	0.93	180.5	9.12	0.64	0.8	0.96	169.8	10.52	0.65	0.83	0.99
	7200	203.4	6.79	0.64	0.82	0.98	195.3	7.87	0.65	0.83	0.99	185.4	9.11	0.66	0.85	1	174.6	10.5	0.69	0.89	1
71°F	4800	199.4	6.79	0.43	0.56	0.68	192	7.88	0.44	0.57	0.69	183.5	9.11	0.45	0.59	0.71	173.3	10.51	0.45	0.59	0.73
	6000	209	6.78	0.44	0.6	0.74	200.9	7.86	0.46	0.61	0.75	191.1	9.09	0.46	0.62	0.78	180.7	10.49	0.47	0.64	0.8
	7200	215.1	6.78	0.46	0.63	0.8	207	7.86	0.45	0.64	0.81	196.8	9.08	0.47	0.65	0.83	186.1	10.48	0.48	0.68	0.86

EL240XCSD + EL240XASD - 2 COMPRESSORS - FULL LOAD

Entering Wet Bulb Temperature	Total Air Volume	Outdoor Air Temperature Entering Outdoor Coil																			
		85°F					95°F					105°F					115°F				
		Total Cool Cap.	Comp. Motor Input	Sensible To Total Ratio (S/T)			Total Cool Cap.	Comp. Motor Input	Sensible To Total Ratio (S/T)			Total Cool Cap.	Comp. Motor Input	Sensible To Total Ratio (S/T)			Total Cool Cap.	Comp. Motor Input	Sensible To Total Ratio (S/T)		
				Dry Bulb					Dry Bulb					Dry Bulb					Dry Bulb		
cfm	kBtuh	kW	75°F	80°F	85°F	kBtuh	kW	75°F	80°F	85°F	kBtuh	kW	75°F	80°F	85°F	kBtuh	kW	75°F	80°F	85°F	
63°F	6400	235	14.42	0.73	0.86	0.99	224.3	15.98	0.74	0.89	1	212.6	17.75	0.76	0.91	1	199.9	19.74	0.78	0.94	1
	8000	246	14.6	0.78	0.93	1	234.1	16.14	0.8	0.96	1	221.9	17.91	0.82	0.98	1	208.4	19.88	0.85	1	1
	9600	254.1	14.74	0.83	0.99	1	241.9	16.26	0.85	1	1	230.2	18.04	0.87	1	1	218	20.06	0.9	1	1
67°F	6400	249.6	14.66	0.58	0.71	0.83	238.2	16.21	0.59	0.72	0.85	225.8	17.98	0.6	0.74	0.87	212.9	19.97	0.61	0.76	0.9
	8000	260.8	14.85	0.6	0.75	0.9	248.7	16.38	0.62	0.78	0.92	235	18.13	0.63	0.8	0.95	221	20.11	0.65	0.82	0.98
	9600	268.3	14.98	0.63	0.8	0.96	255.7	16.49	0.65	0.83	0.99	242.1	18.23	0.67	0.85	1	226.8	20.2	0.68	0.88	1
71°F	6400	263.7	14.9	0.43	0.56	0.68	251.2	16.42	0.43	0.57	0.7	238.5	18.18	0.45	0.58	0.71	225.1	20.17	0.45	0.59	0.73
	8000	274.8	15.08	0.43	0.59	0.73	262.8	16.61	0.44	0.6	0.75	248.1	18.34	0.46	0.62	0.77	234.1	20.32	0.47	0.64	0.8
	9600	283.6	15.23	0.44	0.62	0.79	270	16.73	0.46	0.64	0.8	255.8	18.46	0.47	0.66	0.83	240.3	20.42	0.47	0.67	0.86

RATINGS

ONE OUTDOOR UNIT + TWO INDOOR UNITS

NOTE - For Temperatures and Capacities not shown in tables, see bulletin - Cooling Unit Rating Table Correction Factor Data in Miscellaneous Engineering Data section.

EL180XCSD - (2) EL090XASD - 1 COMPRESSOR - PART LOAD

Entering Wet Bulb Temperature	Total Air Volume	Outdoor Air Temperature Entering Outdoor Coil																			
		65°F					75°F					85°F					95°F				
		Total Cool Cap.	Comp. Motor Input	Sensible To Total Ratio (S/T)			Total Cool Cap.	Comp. Motor Input	Sensible To Total Ratio (S/T)			Total Cool Cap.	Comp. Motor Input	Sensible To Total Ratio (S/T)			Total Cool Cap.	Comp. Motor Input	Sensible To Total Ratio (S/T)		
				Dry Bulb					Dry Bulb					Dry Bulb					Dry Bulb		
cfm	kBtuh	kW	75°F	80°F	85°F	kBtuh	kW	75°F	80°F	85°F	kBtuh	kW	75°F	80°F	85°F	kBtuh	kW	75°F	80°F	85°F	
63°F	3200	68.2	2.62	.74	.86	.97	65.1	3.09	.75	.88	1.00	61.9	3.61	.77	.90	1.00	57.8	4.19	.79	.93	1.00
	4000	72.4	2.59	.78	.92	1.00	68.9	3.06	.81	.95	1.00	64.9	3.58	.83	.98	1.00	61.1	4.17	.86	1.00	1.00
	4800	75.6	2.56	.84	.99	1.00	71.9	3.03	.86	1.00	1.00	67.8	3.56	.89	1.00	1.00	64.2	4.14	.92	1.00	1.00
67°F	3200	73.2	2.58	.60	.71	.82	69.9	3.05	.61	.72	.84	66.1	3.57	.62	.74	.87	62.3	4.16	.64	.77	.90
	4000	77.5	2.54	.63	.76	.89	74.0	3.02	.65	.78	.92	69.6	3.55	.66	.81	.95	65.7	4.13	.68	.83	.98
	4800	80.5	2.52	.67	.82	.96	76.2	3.00	.68	.84	.99	72.6	3.53	.70	.86	1.00	68.0	4.11	.72	.90	1.00
71°F	3200	78.0	2.54	.48	.58	.69	74.2	3.01	.48	.59	.70	70.5	3.54	.49	.61	.72	66.5	4.12	.50	.62	.74
	4000	81.8	2.50	.50	.61	.74	78.3	2.98	.50	.63	.76	74.3	3.51	.51	.65	.78	70.0	4.10	.52	.67	.81
	4800	84.7	2.47	.52	.66	.80	81.4	2.95	.53	.67	.82	77.2	3.49	.54	.69	.84	72.6	4.07	.55	.71	.88

EL180XCSD - (2) EL090XASD - 2 COMPRESSORS - PART LOAD / PART LOAD

Entering Wet Bulb Temperature	Total Air Volume	Outdoor Air Temperature Entering Outdoor Coil																			
		85°F					95°F					105°F					115°F				
		Total Cool Cap.	Comp. Motor Input	Sensible To Total Ratio (S/T)			Total Cool Cap.	Comp. Motor Input	Sensible To Total Ratio (S/T)			Total Cool Cap.	Comp. Motor Input	Sensible To Total Ratio (S/T)			Total Cool Cap.	Comp. Motor Input	Sensible To Total Ratio (S/T)		
				Dry Bulb					Dry Bulb					Dry Bulb					Dry Bulb		
cfm	kBtuh	kW	75°F	80°F	85°F	kBtuh	kW	75°F	80°F	85°F	kBtuh	kW	75°F	80°F	85°F	kBtuh	kW	75°F	80°F	85°F	
63°F	3600	140.9	5.21	.76	.89	1.00	134.4	6.14	.78	.91	1.00	126.8	7.19	.80	.94	1.00	118.9	8.36	.82	.98	1.00
	4500	148.8	5.14	.81	.97	1.00	141.7	6.08	.84	.99	1.00	133.6	7.14	.87	1.00	1.00	125.7	8.31	.90	1.00	1.00
	5400	154.9	5.09	.88	1.00	1.00	147.1	6.04	.91	1.00	1.00	140.4	7.09	.94	1.00	1.00	132.8	8.25	.97	1.00	1.00
67°F	3600	150.9	5.12	.62	.74	.86	144.2	6.06	.63	.75	.88	136.0	7.12	.64	.78	.91	128.6	8.28	.66	.80	.94
	4500	158.8	5.05	.66	.80	.93	150.6	6.01	.67	.82	.96	143.2	7.06	.69	.84	1.00	134.7	8.24	.71	.87	1.00
	5400	164.4	4.99	.70	.85	1.00	156.0	5.96	.71	.89	1.00	147.9	7.02	.73	.91	1.00	138.3	8.21	.76	.95	1.00
71°F	3600	160.6	5.03	.48	.60	.71	152.7	5.99	.49	.61	.73	145.7	7.04	.50	.63	.75	136.8	8.22	.51	.64	.77
	4500	167.6	4.96	.51	.65	.78	160.7	5.92	.52	.66	.80	152.5	6.98	.53	.68	.82	143.2	8.16	.54	.70	.85
	5400	172.8	4.91	.54	.69	.84	165.8	5.87	.55	.71	.87	157.5	6.94	.56	.72	.89	148.0	8.11	.57	.75	.93

EL180XCSD - (2) EL090XASD - 2 COMPRESSORS - FULL LOAD

Entering Wet Bulb Temperature	Total Air Volume	Outdoor Air Temperature Entering Outdoor Coil																			
		85°F					95°F					105°F					115°F				
		Total Cool Cap.	Comp. Motor Input	Sensible To Total Ratio (S/T)			Total Cool Cap.	Comp. Motor Input	Sensible To Total Ratio (S/T)			Total Cool Cap.	Comp. Motor Input	Sensible To Total Ratio (S/T)			Total Cool Cap.	Comp. Motor Input	Sensible To Total Ratio (S/T)		
				Dry Bulb					Dry Bulb					Dry Bulb					Dry Bulb		
cfm	kBtuh	kW	75°F	80°F	85°F	kBtuh	kW	75°F	80°F	85°F	kBtuh	kW	75°F	80°F	85°F	kBtuh	kW	75°F	80°F	85°F	
63°F	4800	180.1	11.31	.77	.90	1.00	171.3	12.66	.79	.93	1.00	160.1	14.17	.81	.96	1.00	150.5	15.89	.84	.99	1.00
	6000	190.2	11.43	.83	.98	1.00	179.7	12.75	.85	1.00	1.00	168.8	14.24	.88	1.00	1.00	157.9	15.96	.92	1.00	1.00
	7200	196.6	11.49	.89	1.00	1.00	186.0	12.83	.92	1.00	1.00	176.5	14.33	.95	1.00	1.00	165.5	16.05	.99	1.00	1.00
67°F	4800	192.1	11.44	.62	.75	.87	182.0	12.78	.63	.77	.89	171.8	14.28	.65	.79	.93	161.0	15.99	.67	.81	.96
	6000	202.0	11.56	.66	.81	.95	191.3	12.88	.68	.83	.98	178.2	14.35	.70	.86	1.00	166.5	16.06	.72	.90	1.00
	7200	208.0	11.62	.71	.87	1.00	196.5	12.94	.72	.90	1.00	184.1	14.42	.74	.94	1.00	171.9	16.11	.78	.97	1.00
71°F	4800	204.1	11.58	.49	.61	.72	193.2	12.91	.50	.63	.74	182.2	14.40	.51	.64	.77	170.8	16.10	.52	.66	.79
	6000	214.0	11.69	.52	.65	.79	202.8	13.02	.53	.67	.81	190.7	14.50	.54	.69	.84	177.9	16.17	.55	.72	.88
	7200	220.5	11.78	.54	.70	.85	208.7	13.09	.56	.72	.88	196.3	14.56	.57	.74	.92	183.3	16.23	.59	.77	.96

RATINGS

ONE OUTDOOR UNIT + TWO INDOOR UNITS

NOTE - For Temperatures and Capacities not shown in tables, see bulletin - Cooling Unit Rating Table Correction Factor Data in Miscellaneous Engineering Data section.

EL240XCSD - (2) EL120XASD - 1 COMPRESSOR - PART LOAD

Entering Wet Bulb Temperature	Total Air Volume	Outdoor Air Temperature Entering Outdoor Coil																			
		65°F					75°F					85°F					95°F				
		Total Cool Cap.	Comp. Motor Input	Sensible To Total Ratio (S/T)			Total Cool Cap.	Comp. Motor Input	Sensible To Total Ratio (S/T)			Total Cool Cap.	Comp. Motor Input	Sensible To Total Ratio (S/T)			Total Cool Cap.	Comp. Motor Input	Sensible To Total Ratio (S/T)		
				Dry Bulb					Dry Bulb					Dry Bulb					Dry Bulb		
cfm	kBtuh	kW	75°F	80°F	85°F	kBtuh	kW	75°F	80°F	85°F	kBtuh	kW	75°F	80°F	85°F	kBtuh	kW	75°F	80°F	85°F	
63°F	4240	85.1	3.44	.76	.88	1.00	81.9	4.00	.77	.90	1.00	77.5	4.64	.78	.92	1.00	73.2	5.35	.80	.95	1.00
	5300	89.8	3.43	.81	.95	1.00	85.9	3.99	.83	.98	1.00	82.0	4.63	.84	1.00	1.00	77.5	5.34	.87	1.00	1.00
	6360	93.1	3.42	.87	1.00	1.00	89.5	3.98	.88	1.00	1.00	85.5	4.62	.92	1.00	1.00	81.1	5.32	.94	1.00	1.00
67°F	4240	90.6	3.42	.61	.73	.85	87.1	3.99	.62	.74	.86	83.2	4.62	.63	.76	.89	78.7	5.33	.64	.78	.91
	5300	94.7	3.42	.65	.79	.93	91.5	3.98	.66	.81	.95	87.5	4.61	.67	.83	.97	82.6	5.32	.69	.85	1.00
	6360	98.0	3.41	.69	.85	1.00	94.4	3.97	.70	.87	1.00	90.3	4.60	.72	.89	1.00	84.9	5.31	.74	.92	1.00
71°F	4240	95.9	3.42	.48	.60	.71	92.4	3.97	.49	.60	.72	88.6	4.61	.49	.62	.74	83.9	5.31	.50	.63	.76
	5300	100.2	3.41	.50	.64	.77	96.9	3.96	.51	.65	.79	92.8	4.60	.52	.66	.80	87.9	5.30	.53	.68	.83
	6360	103.6	3.41	.54	.69	.83	100.1	3.96	.54	.70	.85	96.0	4.59	.56	.71	.88	90.3	5.29	.56	.73	.90

EL240XCSD - (2) EL120XASD - 2 COMPRESSORS - PART LOAD / PART LOAD

Entering Wet Bulb Temperature	Total Air Volume	Outdoor Air Temperature Entering Outdoor Coil																			
		85°F					95°F					105°F					115°F				
		Total Cool Cap.	Comp. Motor Input	Sensible To Total Ratio (S/T)			Total Cool Cap.	Comp. Motor Input	Sensible To Total Ratio (S/T)			Total Cool Cap.	Comp. Motor Input	Sensible To Total Ratio (S/T)			Total Cool Cap.	Comp. Motor Input	Sensible To Total Ratio (S/T)		
				Dry Bulb					Dry Bulb					Dry Bulb					Dry Bulb		
cfm	kBtuh	kW	75°F	80°F	85°F	kBtuh	kW	75°F	80°F	85°F	kBtuh	kW	75°F	80°F	85°F	kBtuh	kW	75°F	80°F	85°F	
63°F	4800	178.1	6.88	.78	.92	1.00	171.6	8.01	.80	.94	1.00	162.3	9.28	.82	.97	1.00	153.0	10.72	.84	1.00	1.00
	6000	186.6	6.86	.85	1.00	1.00	178.8	7.99	.87	1.00	1.00	170.5	9.26	.89	1.00	1.00	161.9	10.67	.92	1.00	1.00
	7200	193.4	6.85	.91	1.00	1.00	186.8	7.97	.93	1.00	1.00	179.3	9.24	.96	1.00	1.00	170.4	10.64	.99	1.00	1.00
67°F	4800	189.5	6.85	.64	.77	.89	181.8	7.98	.64	.78	.91	173.8	9.25	.65	.79	.93	164.0	10.67	.67	.82	.96
	6000	196.7	6.84	.67	.83	.97	189.7	7.96	.69	.85	1.00	181.4	9.23	.70	.87	1.00	170.9	10.64	.72	.90	1.00
	7200	202.9	6.84	.72	.89	1.00	195.6	7.95	.73	.91	1.00	186.4	9.22	.75	.94	1.00	175.9	10.62	.78	.98	1.00
71°F	4800	199.6	6.84	.50	.62	.74	192.5	7.95	.50	.63	.76	185.6	9.22	.51	.64	.77	174.6	10.63	.52	.66	.80
	6000	207.9	6.84	.52	.66	.81	200.9	7.94	.53	.67	.83	193.1	9.20	.54	.70	.85	182.7	10.60	.54	.72	.88
	7200	213.8	6.84	.55	.72	.88	206.4	7.92	.56	.73	.90	198.6	9.19	.55	.75	.92	187.1	10.58	.58	.79	.96

EL240XCSD - (2) EL120XASD - 2 COMPRESSORS - FULL LOAD

Entering Wet Bulb Temperature	Total Air Volume	Outdoor Air Temperature Entering Outdoor Coil																			
		85°F					95°F					105°F					115°F				
		Total Cool Cap.	Comp. Motor Input	Sensible To Total Ratio (S/T)			Total Cool Cap.	Comp. Motor Input	Sensible To Total Ratio (S/T)			Total Cool Cap.	Comp. Motor Input	Sensible To Total Ratio (S/T)			Total Cool Cap.	Comp. Motor Input	Sensible To Total Ratio (S/T)		
				Dry Bulb					Dry Bulb					Dry Bulb					Dry Bulb		
cfm	kBtuh	kW	75°F	80°F	85°F	kBtuh	kW	75°F	80°F	85°F	kBtuh	kW	75°F	80°F	85°F	kBtuh	kW	75°F	80°F	85°F	
63°F	6400	232.9	14.59	.79	.92	1.00	220.4	16.11	.80	.95	1.00	210.2	17.85	.82	.97	1.00	198.2	19.80	.85	1.00	1.00
	8000	242.6	14.77	.85	1.00	1.00	230.2	16.27	.87	1.00	1.00	218.3	17.99	.90	1.00	1.00	207.0	19.95	.93	1.00	1.00
	9600	250.5	14.91	.91	1.00	1.00	240.0	16.43	.94	1.00	1.00	229.3	18.17	.96	1.00	1.00	217.8	20.12	1.00	1.00	1.00
67°F	6400	245.4	14.82	.63	.76	.89	234.0	16.34	.64	.78	.92	221.7	18.05	.66	.80	.94	209.4	20.00	.68	.83	.97
	8000	256.1	14.98	.68	.83	.98	244.3	16.51	.69	.85	1.00	230.6	18.19	.71	.88	1.00	216.7	20.11	.73	.91	1.00
	9600	263.0	15.12	.72	.90	1.00	250.6	16.61	.75	.92	1.00	237.1	18.30	.76	.95	1.00	223.4	20.21	.79	.99	1.00
71°F	6400	258.6	15.05	.49	.62	.74	249.3	16.58	.50	.63	.76	234.9	18.26	.51	.65	.78	222.3	20.19	.53	.67	.81
	8000	270.6	15.26	.52	.67	.82	258.5	16.74	.53	.69	.84	245.6	18.42	.54	.71	.86	229.8	20.31	.55	.73	.89
	9600	278.1	15.38	.55	.72	.88	264.5	16.82	.56	.73	.91	250.9	18.51	.58	.76	.94	235.9	20.40	.59	.78	.98

RATINGS

ONE OUTDOOR UNIT + TWO INDOOR UNITS

NOTE - For Temperatures and Capacities not shown in tables, see bulletin - Cooling Unit Rating Table Correction Factor Data in Miscellaneous Engineering Data section.

EL120XCSS + (2) CX35-60D + (2) EL296UH135XE60D - 1 COMPRESSOR - PART LOAD

Entering Wet Bulb Temperature	Total Air Volume	Outdoor Air Temperature Entering Outdoor Coil																							
		65°F						75°F						85°F						95°F					
		Total Cool Cap.	Comp. Motor Input	Sensible To Total Ratio (S/T)			Total Cool Cap.	Comp. Motor Input	Sensible To Total Ratio (S/T)			Total Cool Cap.	Comp. Motor Input	Sensible To Total Ratio (S/T)			Total Cool Cap.	Comp. Motor Input	Sensible To Total Ratio (S/T)						
				Dry Bulb					Dry Bulb					Dry Bulb					Dry Bulb						
cfm	kBtuh	kW	75°F	80°F	85°F	kBtuh	kW	75°F	80°F	85°F	kBtuh	kW	75°F	80°F	85°F	kBtuh	kW	75°F	80°F	85°F					
63°F	2080	81.0	3.50	.71	.82	.94	78.2	4.07	.72	.84	.96	74.6	4.73	.73	.86	.98	70.6	5.46	.74	.88	1.00				
	2600	85.7	3.49	.74	.88	1.00	82.6	4.05	.75	.89	1.00	78.8	4.70	.77	.92	1.00	74.6	5.43	.79	.95	1.00				
	3120	89.1	3.48	.78	.93	1.00	85.9	4.04	.80	.95	1.00	82.2	4.69	.81	.98	1.00	77.6	5.41	.83	1.00	1.00				
67°F	2080	85.5	3.49	.57	.68	.79	82.5	4.06	.57	.69	.80	79.0	4.70	.58	.70	.82	75.0	5.43	.59	.72	.84				
	2600	90.5	3.48	.59	.72	.84	87.4	4.04	.59	.73	.86	83.5	4.68	.60	.74	.88	79.2	5.41	.62	.77	.91				
	3120	94.1	3.46	.61	.76	.90	90.8	4.03	.62	.77	.92	86.8	4.66	.63	.79	.94	82.3	5.39	.65	.81	.97				
71°F	2080	90.5	3.47	.44	.55	.66	87.5	4.04	.44	.56	.66	83.9	4.68	.44	.56	.67	79.7	5.40	.44	.57	.69				
	2600	95.5	3.46	.45	.57	.70	92.2	4.03	.45	.58	.71	88.3	4.67	.45	.58	.72	83.7	5.39	.46	.60	.74				
	3120	99.0	3.46	.46	.60	.73	95.7	4.02	.46	.61	.75	91.5	4.65	.47	.62	.77	86.8	5.38	.47	.63	.79				

EL120XCSS + (2) CX35-60D + (2) EL296UH135XE60D - 1 COMPRESSOR - FULL LOAD

Entering Wet Bulb Temperature	Total Air Volume	Outdoor Air Temperature Entering Outdoor Coil																							
		85°F						95°F						105°F						115°F					
		Total Cool Cap.	Comp. Motor Input	Sensible To Total Ratio (S/T)			Total Cool Cap.	Comp. Motor Input	Sensible To Total Ratio (S/T)			Total Cool Cap.	Comp. Motor Input	Sensible To Total Ratio (S/T)			Total Cool Cap.	Comp. Motor Input	Sensible To Total Ratio (S/T)						
				Dry Bulb					Dry Bulb					Dry Bulb					Dry Bulb						
cfm	kBtuh	kW	75°F	80°F	85°F	kBtuh	kW	75°F	80°F	85°F	kBtuh	kW	75°F	80°F	85°F	kBtuh	kW	75°F	80°F	85°F					
63°F	3200	113.3	7.41	.72	.85	.97	108.6	8.23	.73	.86	.99	103.6	9.17	.75	.88	1.00	98.0	10.25	.76	.91	1.00				
	4000	119.1	7.52	.76	.91	1.00	113.9	8.32	.78	.93	1.00	108.5	9.26	.80	.95	1.00	102.6	10.34	.82	.98	1.00				
	4800	123.5	7.59	.80	.96	1.00	118.0	8.39	.82	.99	1.00	112.1	9.32	.84	1.00	1.00	106.4	10.40	.87	1.00	1.00				
67°F	3200	119.4	7.52	.58	.70	.81	114.2	8.33	.58	.71	.83	109.0	9.25	.59	.72	.85	103.3	10.34	.60	.74	.87				
	4000	125.5	7.62	.60	.74	.87	120.0	8.43	.61	.75	.89	114.2	9.36	.62	.77	.92	108.0	10.44	.63	.79	.95				
	4800	130.0	7.71	.63	.78	.93	124.3	8.50	.64	.80	.96	118.1	9.42	.65	.82	.98	111.2	10.47	.66	.84	1.00				
71°F	3200	126.4	7.64	.44	.56	.67	121.0	8.45	.44	.57	.69	115.3	9.37	.45	.58	.70	109.2	10.45	.45	.59	.72				
	4000	132.5	7.75	.46	.59	.72	126.6	8.54	.46	.59	.73	120.3	9.46	.46	.61	.75	113.5	10.52	.47	.62	.77				
	4800	136.6	7.82	.46	.62	.76	130.3	8.60	.47	.63	.78	123.9	9.53	.48	.64	.80	116.9	10.59	.48	.66	.82				

REVISIONS

Sections	Description of Change
AHRI System Matches	Updated TXV usage for One Outdoor Unit With Two Indoor Units.



Visit us at www.Lennox.com

For the latest technical information, www.LennoxCommercial.com

Contact us at 1-800-4-LENNOX

NOTE - Due to Lennox' ongoing commitment to quality, Specifications, Ratings and Dimensions subject to change without notice and without incurring liability. Improper installation, adjustment, alteration, service or maintenance can cause property damage or personal injury. Installation and service must be performed by a qualified installer and servicing agency.

©2024 Lennox Industries, Inc.