

INSTALLATION INSTRUCTIONS

**RETAIN THESE INSTRUCTIONS
FOR FUTURE REFERENCE**

LGT/LCT302H (25 TON)

LGT/LCT360H (30 TON)

GAS AND COOLING PACKAGED UNITS

508634-01

6/2024

R-454B

⚠ WARNING
 Improper installation, adjustment, alteration, service, or maintenance can cause property damage, personal injury, or loss of life. Installation and service must be performed by a licensed professional HVAC installer or equivalent, service agency, or the gas supplier.

Table of Contents

Parts Arrangement	4	Refrigerant Leak Detection System	23
Dimensions	4	Cooling Start-Up	23
Shipping and Packing List	5	Diagnostic Sensors	36
General	5	RDS Sensors	38
Requirements	5	Gas Heat Start-Up (Gas Units)	39
Unit Support	7	Heating Operation and Adjustments	40
Duct Connection	8	Electric Heat Start-Up (LCH Units)	41
Rigging Unit for Lifting	8	Variable Air Volume Start-Up	41
Condensate Drains	8	Multi-Staged Air Volume Start-Up	43
Connect Gas Piping (Gas Units)	9	Hot Gas Reheat Start-Up and Operation	46
Pressure Test Gas Piping (Gas Units)	10	Optional Economizer Settings	49
High Altitude Derate	10	Optional Outdoor Air CFM Control	54
Factory-Installed Options	10	Preventative Maintenance / Repair	55
Electrical Connections	12	Decommissioning	63
Mobile Service App	15		
Blower Operation and Adjustments	18		

Attention!

Use this QR code to download the mobile service app. Follow the prompts to pair the app with the Unit Controller. Refer to the “Mobile Service App” section in this manual. The QR code is also available in the unit control area.



The app can be downloaded from the appropriate iOS or Android store. Look for the following icon.



CAUTION

As with any mechanical equipment, contact with sharp sheet metal edges can result in personal injury. Take care while handling this equipment and wear gloves and protective clothing.

WARNING

Only manufacturer approved auxiliary devices are permitted to be installed in this unit.

WARNING

If this appliance is conditioning a space with an area smaller than T_{Amin} or stored in a space with an area smaller than A_{min} as defined by this instruction, then that space must be without continuously operating open flames (e.g. an operating gas appliance) or other potential ignition sources (e.g. an operating electric heater or similar hot surface). A flame-producing device may be installed in the same space if the device is provided with an effective flame arrest system.

CAUTION

Auxiliary devices which may be a potential ignition source shall not be installed in the duct work. Examples of such potential ignition sources are hot surfaces with a temperature exceeding 700°C and electric switching devices.

CAUTION

The appliance is not to be used by persons (including children) with reduced physical, sensory or mental capabilities, or lack of experience and knowledge, unless they have been given supervision or instruction.

CAUTION

Children should be supervised not to play with the appliance.

CAUTION

Any personnel installing, decommissioning, or performing maintenance on the unit must be properly trained with A2L refrigerants.

CAUTION

Servicing shall be performed only as recommended by the manufacturer.

WARNING

•This appliance must be installed in accordance with local and national wiring regulations.

•If the appliance is not fitted with an option for full disconnection from power, a means of disconnection must be incorporated in the fixed wiring in accordance with national and local wiring regulations.

CAUTION

Leak Detection System installed. Unit must be powered except for service.

WARNING

•Do not use means to accelerate the defrosting process or to clean, other than those recommended by the manufacturer.

•The appliance shall be stored in a room without continuously operating ignition sources (for example: open flames, an operating gas appliance, or an operating electric heater).

•Do not pierce or burn.

•Be aware that refrigerants may not contain an odor

WARNING

Ducts connected to an appliance shall not contain a potential ignition source.

IMPORTANT

Pipe work, including piping material, pipe routing, and installation shall include protection from physical damage in operation and service, and be in compliance with national and local codes and standards, such as ASHRAE 15, ASHRAE 15.2, IAPMO Uniform Mechanical Code, ICC International Mechanical Code, or CSA B52. All field joints shall be accessible for inspection prior to being covered or enclosed.

IMPORTANT

Refrigerant sensors for refrigerant detection systems shall only be replaced with sensors specified by the appliance manufacturer.

CAUTION

This unit is equipped with electrically powered safety measures. To be effective, the unit must be electrically powered at all times after installation, other than when servicing.

A2L Refrigerant Considerations

Ensure that the work area is adequately ventilated before breaking into the system or conducting any hot work. A degree of ventilation shall continue during the period that the work is carried out. The ventilation should safely disperse any released refrigerant and preferably expel it externally into the atmosphere.

Check that cabling will not be subject to wear, corrosion, excessive pressure, vibration, sharp edges or any other adverse environmental effects, taking into account the effects of aging or continual vibration from sources such as compressors or fans.

Under no circumstances shall potential sources of ignition be used when searching for or detection of refrigerant leaks. A halide torch (or any other detector using a naked flame) shall not be used. Electronic leak detectors may be used to detect refrigerant leaks but, in the case of flammable refrigerants, the sensitivity may not be adequate, or may need re-calibration. (Detection equipment shall be calibrated in a refrigerant-free area.) Ensure that the detector is not a potential source of ignition and is suitable for the refrigerant used. Leak detection equipment shall be set at a percentage of the LFL of the refrigerant and shall be calibrated to the refrigerant employed, and the appropriate percentage of gas (25 % maximum) is confirmed. Leak detection fluids are also suitable for use with most refrigerants but the use of detergents containing chlorine shall be avoided as the chlorine may react with the refrigerant and corrode the copper pipe-work. If a leak is suspected, all naked flames shall be removed/extinguished. If a leakage of refrigerant is found which requires brazing, all of the refrigerant shall be recovered from the system, or isolated (by means of shut off valves) in a part of the system remote from the leak.

When breaking into the refrigerant circuit to make repairs – or for any other purpose – conventional procedures shall be used. However, for flammable refrigerants it is important that best practices be followed since flammability is a consideration. The following procedure shall be adhered to:

- Safely remove refrigerant following local and national regulations.

- Evacuate the circuit.

- Purge the circuit with inert gas.

- Evacuate.

- Purge the circuit with inert gas.

- Open the circuit

The refrigerant charge shall be recovered into the correct recovery cylinders if venting is not allowed by local and national codes. For appliances containing flammable refrigerants, the system shall be purged with oxygen-free nitrogen to render the appliance safe for flammable refrigerants. This process might need to be repeated several times. Compressed air or oxygen shall not be used for purging refrigerant systems. Refrigerants purging shall be achieved by breaking the vacuum in the system with oxygen-free nitrogen and continuing to fill until the working pressure is achieved, then venting to atmosphere, and finally pulling down to a vacuum. This process shall be vented down to atmospheric pressure to enable work to take place. Ensure that the outlet for the vacuum pump is not close to any potential ignition sources and that ventilation is available.

LGT/LCT302, 360

Parts Arrangement

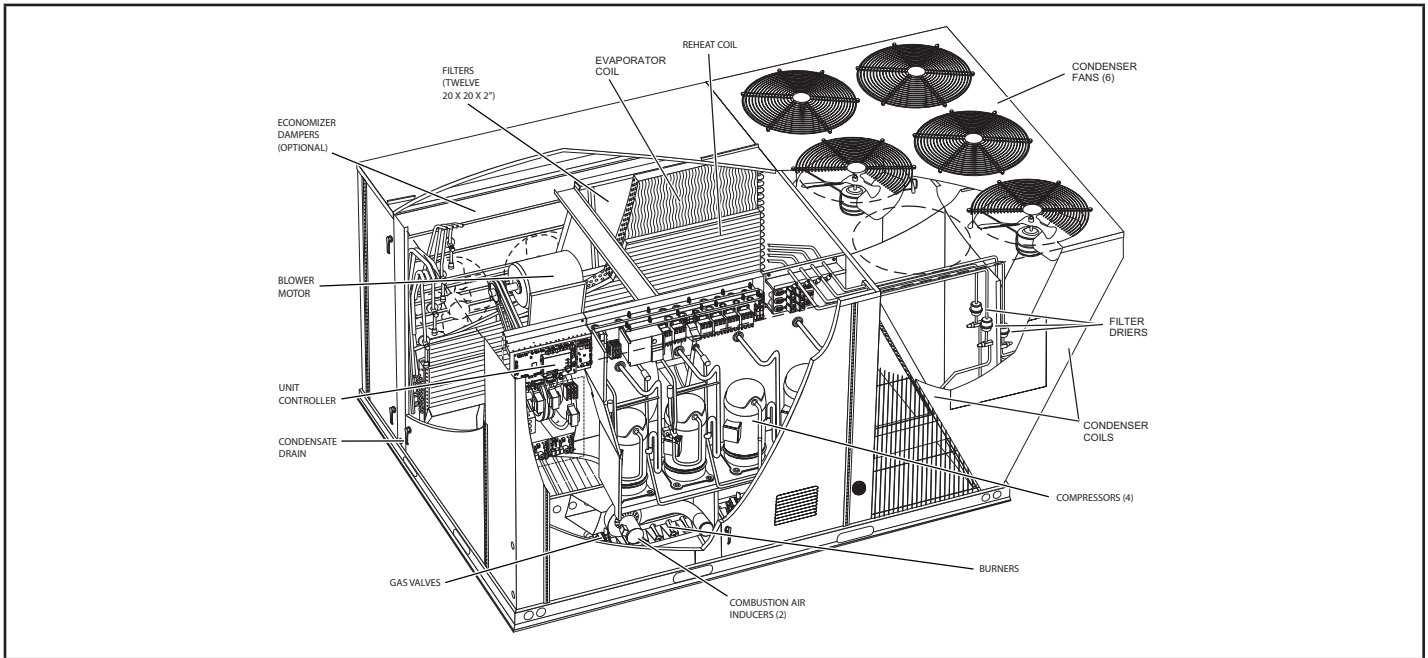

LGT/LCT302, 360

Dimensions - LGT Heat Section Shown

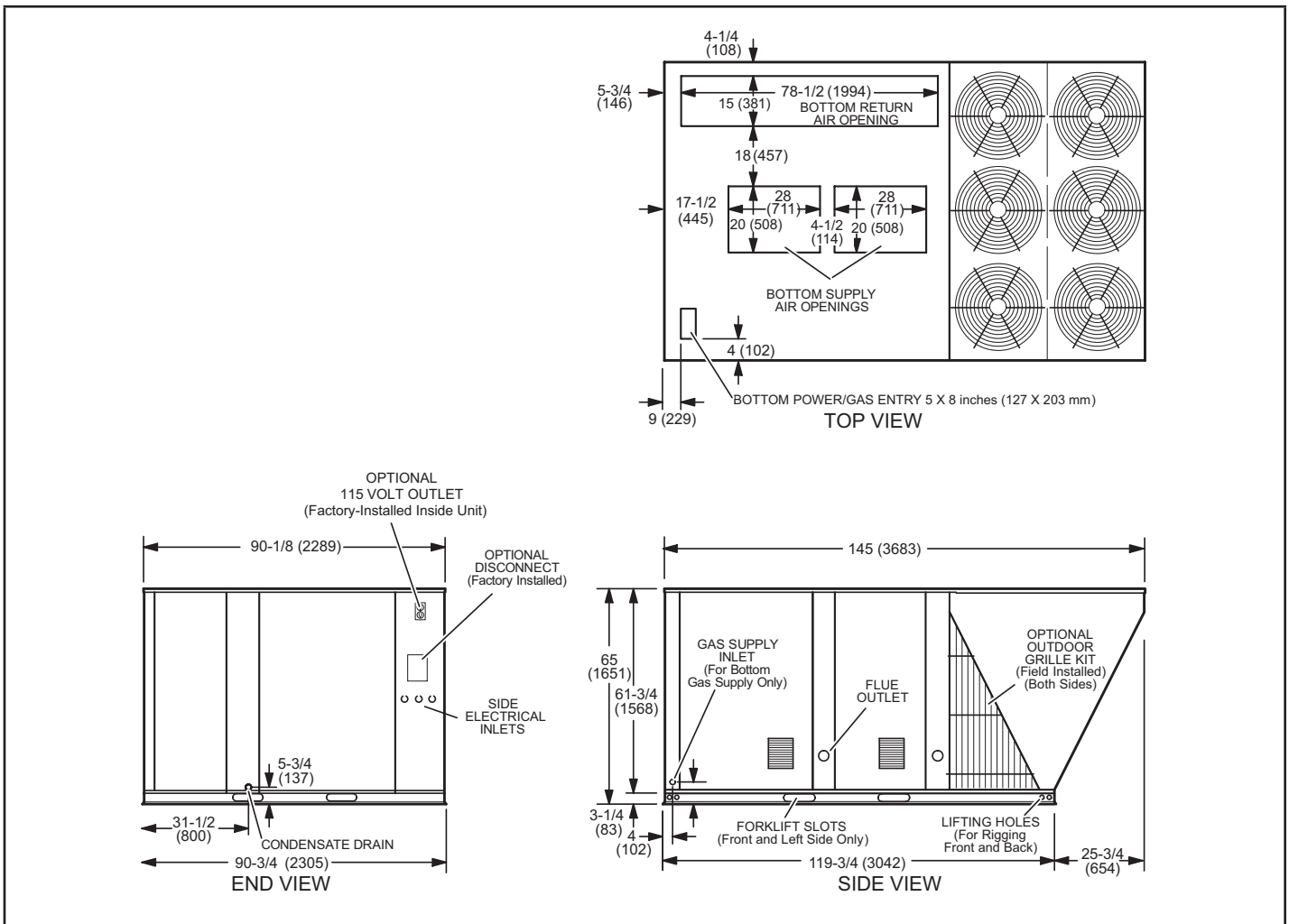

Shipping and Packing List

Package 1 of 1 contains:

- 1 - Assembled unit.

Check unit for shipping damage. Receiving party should contact last carrier immediately if shipping damage is found.

General

These instructions are intended as a general guide and do not supersede local codes in any way. Authorities having jurisdiction should be consulted before installation.

Units are available in 25 and 30 ton cooling capacities. The gas/electric units are available in 260,000, 360,000, or 480,000-Btuh heating inputs. Optional electric heat is factory or field-installed in electric/electric units. All units contain four compressors.

LGT/LCT302 and 360 are available in constant air volume, variable air volume, or multi-staged air volume. Refer to the 9th character of the model number to determine type of blower:

V - Variable Air Volume

M - Multi-Stage Air Volume

Units are available using R454-B, an ozone-friendly HFC refrigerant. Refer to the Cooling Start-Up section for precautions when installing unit.

! IMPORTANT

Supply air VFD motor rotation is controlled independently from scroll compressor rotation. See Blower Operation and Adjustments section for correct compressor rotation. Compressor damage due to improper rotation is the responsibility of the installer.

Requirements

Use of this unit as a construction heater or air conditioner is not recommended during any phase of construction. Very low return air temperatures, harmful vapors and operation of the unit with clogged or misplaced filters will damage the unit.

If this unit has been used for heating or cooling of buildings or structures under construction, the following conditions must be met or the warranty will be void:

- The vent hood must be installed per these installation instructions.
- A room thermostat must control the unit. The use of fixed jumpers that will provide continuous heating or cooling is not allowed.
- A pre-filter must be installed at the entry to the return air duct.
- The return air duct must be provided and sealed to the unit.
- Return air temperature range between 55°F (13°C) and 80°F (27°C) must be maintained.

- Air filters must be replaced and pre-filters must be removed upon construction completion.
- The input rate and temperature rise must be set per the unit rating plate.
- The heat exchanger, components, duct system, air filters, and evaporator coil must be thoroughly cleaned following final construction clean-up.
- The unit operating conditions (including airflow, cooling operation, ignition, input rate, temperature rise, and venting) must be verified according to these installation instructions.

See FIGURE 1 and TABLE 1 for unit clearances.

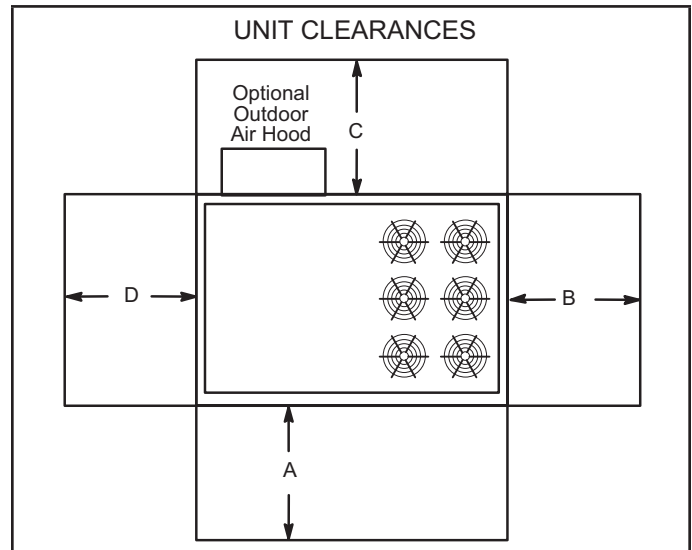

FIGURE 1

Minimum R454B Space and CFM Requirements

Minimum Airflow		
Unit	Q_{min} (CFM)	Q_{min} (m ³ h)
LCT/LGT302	178	303
LCT/LGT360	169	286

¹ **NOTE** - The minimum airflow is the lowest CFM allowed during venting operation (leak mitigation).

Minimum Room Area of Conditioned Space		
Unit	TA_{min} (ft ²)	TA_{min} (m ²)
LCT/LGT302	99	9.19
LCT/LGT360	94	8.68

² **NOTE** - The minimum room area of conditioned space is the smallest area the unit can service.

Refrigerant Charge R-454B		
Unit	M_c (lbs)	M_c (kg)
LGT/LCT302 RH & No RH Stage 1	6.75	3.06
LGT/LCT302 RH & No RH Stage 2	6.50	2.95
LGT/LCT302 RH & No RH Stage 3	6.69	3.03
LGT/LCT302 RH & No RH Stage 4	6.81	3.09
LGT/LCT360 No RH Stage 1	6.38	2.89
LGT/LCT360 No RH Stage 2	6.81	3.09
LGT/LCT360 No RH Stage 3	6.63	3.01
LGT/LCT360 No RH Stage 4	6.38	2.89
LGT/LCT360 RH Stage 1	7.75	3.52
LGT/LCT360 RH Stage 2	7.50	3.40
LGT/LCT360 RH Stage 3	6.88	3.12
LGT/LCT360 RH Stage 4	6.75	3.06

Altitude Adjustment Factor									
Halt	0	200	400	600	800	1000	1200	1400	1600
AF	1	1	1	1	1.02	1.05	1.04	1.1	1.12
Halt	1600	1800	2000	2200	2400	2600	2800	3000	3200
AF	1.12	1.15	1.18	1.21	1.25	1.28	1.32	1.36	1.4

³ **NOTE** - Use the Altitude Adjustment Factor to adjust the values in the tables above to different altitudes. Find the relevant altitude above sea level in the two "Halt" rows and then multiply the value needed from the tables above by the altitude factor number. Example: For the minimum airflow in CFM for an LCT/LGT302 at 1000 ft. above sea level, multiply 178 by 1.05 to get 186.9 CFM as the new Q_{min} .

**TABLE 1
UNIT CLEARANCES**

¹ Unit Clearance	A in. (mm)	B in. (mm)	C in. (mm)	D* in. (mm)	Top Clearance
Service Clearance	60 (1524)	36 (914)	36 (914)	66 (1676)	Unobstructed
Service Clearance - Units With High Static Exhaust Fans	60 (1524)	36 (914)	80 (2032)	66 (1676)	Unobstructed
Clearance to Combustibles - LGH Units	36 (914)	1 (25)	1 (25)	1 (25)	Unobstructed
Minimum Operation Clearance	45 (1143)	36 (914)	36 (914)	41 (1041)	Unobstructed
Minimum Operation Clearance - Units With High Static Exhaust Fans	45 (1143)	36 (914)	80 (2032)	41 (1041)	Unobstructed

NOTE - Entire perimeter of unit base requires support when elevated above mounting surface.

*Not applicable on units equipped with horizontal barometric relief dampers.

¹**Service Clearance** - Required for removal of serviceable parts.

Clearance to Combustibles - Required clearance to combustible material (gas units).

Minimum Operation Clearance - Required for proper unit operation.

⚠ WARNING



Electric shock hazard and danger of explosion. Can cause injury, death or product or property damage. Turn off gas and electrical power to unit before performing any maintenance or servicing operations on the unit. Follow lighting instructions attached to unit when putting unit back into operation and after service or maintenance.

⚠ IMPORTANT

The Clean Air Act of 1990 bans the intentional venting of refrigerant (CFC's and HFC's) as of July 1, 1992. Approved methods of recovery, recycling, or reclaiming must be followed. Fines and/or incarceration may be levied for non compliance.

⚠ CAUTION

As with any mechanical equipment, contact with sharp sheet metal edges can result in personal injury. Take care while handling this equipment and wear gloves and protective clothing.

⚠ NOTICE

Roof Damage!
This system contains both refrigerant and oil. Some rubber roofing material may absorb oil, causing the rubber to swell. Bubbles in the rubber roofing material can cause leaks. Protect the roof surface to avoid exposure to refrigerant and oil during service and installation. Failure to follow this notice could result in damage to roof surface.

Unit Support

In downflow discharge installations, install the unit on a non-combustible surface only. Unit may be installed on combustible surfaces when used in horizontal discharge applications or in downflow discharge applications when installed on an S6CURB roof mounting frame.

NOTE - Securely fasten roof frame to roof per local codes.

⚠ CAUTION

To reduce the likelihood of supply / return air bypass and promote a proper seal with the RTU, duct work / duct drops / diffuser assemblies must be supported independently to the building structure.

A-Downflow Discharge Application

Roof Mounting with S6CURB

- 1 - The roof mounting frame must be installed, flashed, and sealed in accordance with the instructions provided with the frame.
- 2 - The roof mounting frame should be square and level to 1/16 inch per linear foot (5 mm per linear meter) in any direction.
- 3 - Dust must be attached to the roof mounting frame and not to the unit; supply and return plenums must be installed before setting the unit.

Installer's Roof Mounting Frame

Many types of roof frames can be used to install the unit depending upon different roof structures. Items to keep in mind when using the building frame or supports are:

- 1 - The base is fully enclosed and insulated, so an enclosed frame is not required.
- 2 - The frames or supports must be constructed with non-combustible materials and should be square and level to 1/16 inch per linear foot (5 mm per linear meter) in any direction.
- 3 - Frame or supports must be high enough to prevent any form of moisture from entering unit.

Recommended minimum frame height is 14 inch (356 mm).

- 4 - Dust must be attached to the roof mounting frame and not to the unit. Supply and return plenums must be installed before setting the unit.
- 5 - Units require support along all four sides of unit base. Supports must be constructed of steel or suitably treated wood materials.

NOTE - When installing a unit on a combustible surface for downflow discharge applications, an S6CURB roof mounting frame is required.

B-Horizontal Discharge Applications.

- 1 - Units installed in horizontal airflow applications must use an LARMFH30/36 horizontal roof mounting frame. The supply air duct connects to the horizontal supply air opening to the LARMFH30/36. The return air duct connects to the unit horizontal return air opening. Refer to unit dimensions.
- 2 - Specified installation clearances must be maintained when installing units. Refer to FIGURE 1.
- 3 - Top of support slab should be approximately 4 inch (102 mm) above the finished grade and located so no run-off water from higher ground can collect around the unit.
- 4 - Units require support along all four sides of unit base. Supports must be constructed of steel or suitably treated wood materials.

Duct Connection

All exterior ducts, joints and openings in roof or building walls must be insulated and weather-proofed with flashing and sealing compounds in accordance with applicable codes. Any duct passing through an unconditioned space must be insulated.

⚠ CAUTION

In downflow applications, do not drill or punch holes in base of unit. Leaking in roof may occur if unit base is punctured.

Rigging Unit for Lifting

Rig unit for lifting by attaching four cables to holes in unit base rail. See FIGURE 2.

- 1 - Detach wooden base protection before rigging.
- 2 - Connect rigging to the unit base using both holes in each corner.
- 3 - All panels must be in for rigging.
- 4 - Place field-provided H-style pick in place just above top edge of unit. Frame must be of adequate strength and length (H-style pick prevents damage to unit).

RIGGING

Unit	*Weight	
	Lbs.	Kg.
LGT/LCT 302, 360	3585	1626

*Maximum weight with all available factory-installed accessories.

LIFTING POINT SHOULD BE DIRECTLY ABOVE CENTER OF GRAVITY

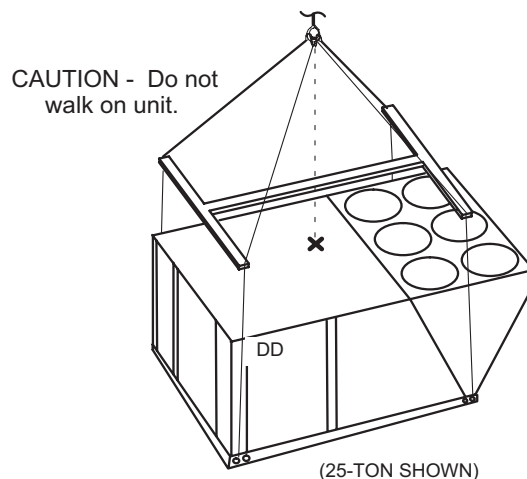

IMPORTANT - ALL PANELS MUST BE IN PLACE FOR RIGGING.

FIGURE 2

Condensate Drains

Remove cap and make drain connection to the 1 inch N.P.T. drain coupling provided on unit. A trap must be installed between drain connection and an open vent for proper condensate removal. See FIGURE 3. It is sometimes acceptable to drain condensate onto the roof or grade; however, a tee should be fitted to the trap to direct condensate downward. The condensate line must be vented. Check local codes concerning condensate disposal. Refer to page 4 for condensate drain location.

NOTE - The drain pan is made with a glass reinforced engineered plastic capable of withstanding typical joint torque but can be damaged with excessive force. Tighten pipe nipple hand tight and turn an additional quarter turn.

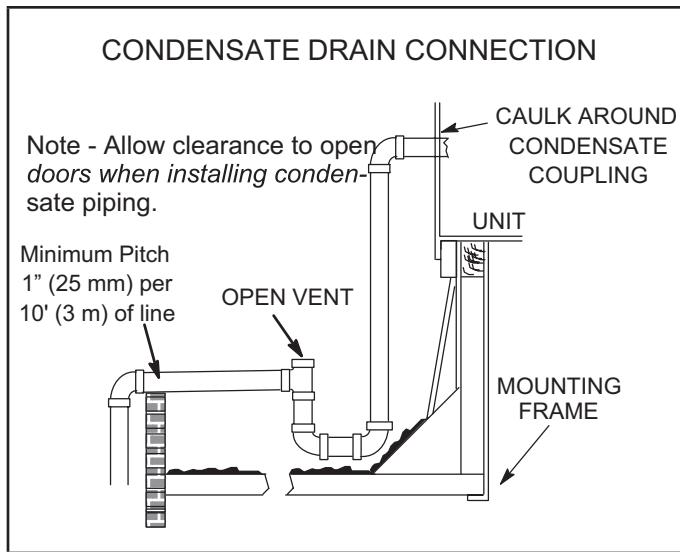

FIGURE 3

Connect Gas Piping (Gas Units)

Before connecting piping, check with gas company or authorities having jurisdiction for local code requirements. When installing gas supply piping, length of run from gas meter must be considered in determining pipe size for 0.5 inch w.c. (0.12 kPa) maximum pressure drop. Do not use supply pipe smaller than unit gas connection. For natural gas units, operating pressure at the unit gas connection must be a minimum of 4.7 inch w.c. (1.17 kPa) and a maximum of 10.5 inch w.c. (2.60 kPa). For LP/propane gas units, operating pressure at the unit gas connection must be a minimum of 11 inch w.c. (2.74 kPa) and a maximum of 13.5 inch w.c. (3.36 kPa).

When making piping connections a drip leg should be installed on vertical pipe runs to serve as a trap for sediment or condensate. A 1/8 inch N.P.T. plugged tap is located on gas valve for test gauge connection. Refer to Heating Start-Up section for tap location. Install a ground joint union between the gas control manifold and the main manual shut-off valve. See FIGURE 4 for gas supply piping entering outside the unit. FIGURE 5 shows complete bottom gas entry piping.

Compounds used on threaded joints of gas piping shall be resistant to the action of liquefied petroleum gases.

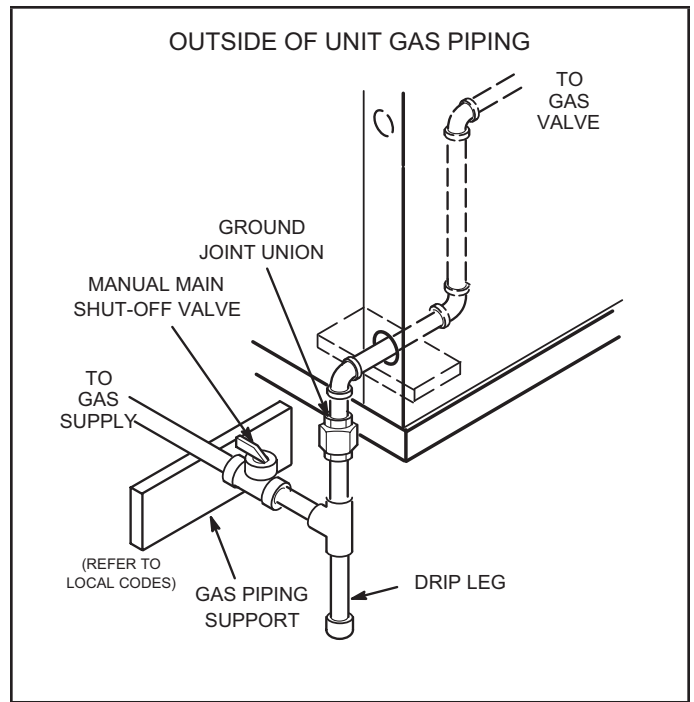

FIGURE 4

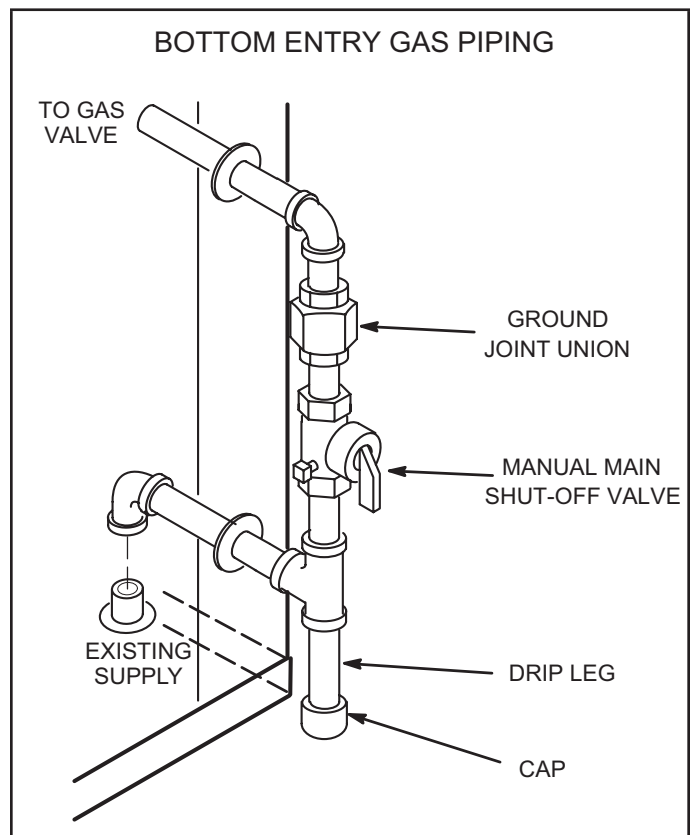

FIGURE 5

Pressure Test Gas Piping (Gas Units)

When pressure testing gas lines, the gas valve must be disconnected and isolated. Gas valves can be damaged if subjected to more than 0.5 psig (3.5 kPa). See FIGURE 6.

NOTE - Codes may require that manual main shut-off valve and union (furnished by installer) be installed in gas line external to unit. Union must be of the ground joint type.

After all connections have been made, check all piping connections for gas leaks. Also check existing unit gas connections up to the gas valve; loosening may occur during installation. Use a leak detection solution or other preferred means. Do not use matches candles or other sources of ignition to check for gas leaks.

⚠ CAUTION

Some soaps used for leak detection are corrosive to certain metals. Carefully rinse piping thoroughly after leak test has been completed. Do not use matches, candles, flame or other sources of ignition to check for gas leaks.

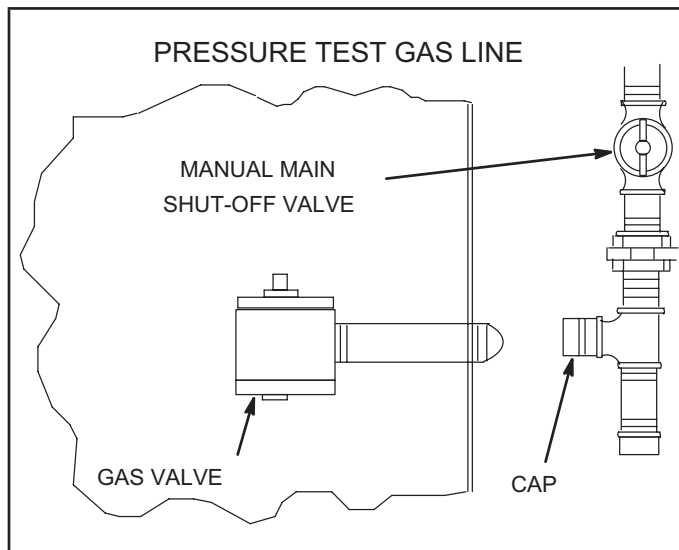

FIGURE 6

⚠ WARNING



Danger of explosion. Can cause injury or product or property damage. Do not use matches, candles, flame or other sources of ignition to check for leaks.

NOTE - In case emergency shut down is required, turn off the main manual shut-off valve and disconnect main power to unit. These devices should be properly labeled by the installer.

High Altitude Derate

Locate the high altitude conversion sticker in the unit literature bag. Fill out the conversion sticker and affix next to the unit nameplate.

Refer to TABLE 2 for high altitude adjustments.

TABLE 2
HIGH ALTITUDE DERATE

Altitude Ft.*	Gas Manifold Pressure
2000-4500	See unit nameplate
4500 and above	Derate 2% / 1000 ft. above sea level

*Units installed at 0-2000 ft. do not need to be modified.

NOTE - This is the only permissible derate for these units.

Factory-Installed Options

A-Economizer

The Unit Controller A55 controls economizer operation and provides potentiometers to control minimum damper position and enthalpy control adjustments. See the economizer control settings section.

B-Intake Hood

Outdoor air hood is shipped folded down over the horizontal supply air opening. The intake hood filters and support brackets are shipped unassembled in the blower compartment. Install as follows:

- 1 - Remove left side from hood top panel. See FIGURE 7.

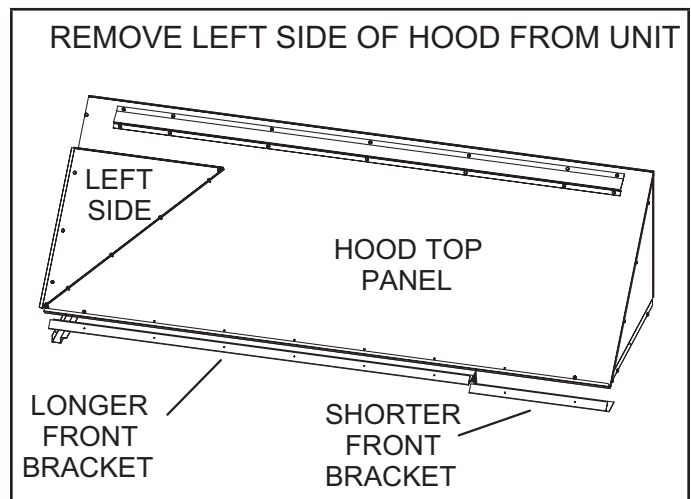

FIGURE 7

- 2 - Remove and retain screws securing hood to unit.
- 3 - Lift (rotate) the bottom of the hood top panel and attach left side to hood top panel. See FIGURE 8.
- 4 - Secure sides of hood to unit mullions with retained screws.
- 5 - Caulk hinge opening on each end of air hood.
- 6 - Install back filter bracket on unit division panel as shown in FIGURE 9.

- 7 - Secure side seals to the hood sides as shown in FIGURE 10.
- 8 - Install longer front filter bracket on hood top as shown in FIGURE 7 and FIGURE 9. Insert four filters.
- 9 - Slide fifth filter into back filter bracket and hold in place at the top of the opening with the shorter front bracket. Align holes on hood with bracket holes and secure filter bracket with sheet metal screws.

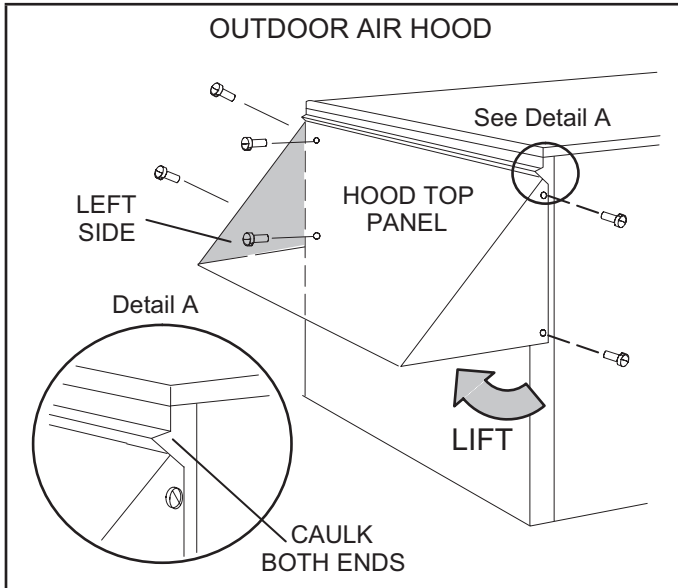

FIGURE 8

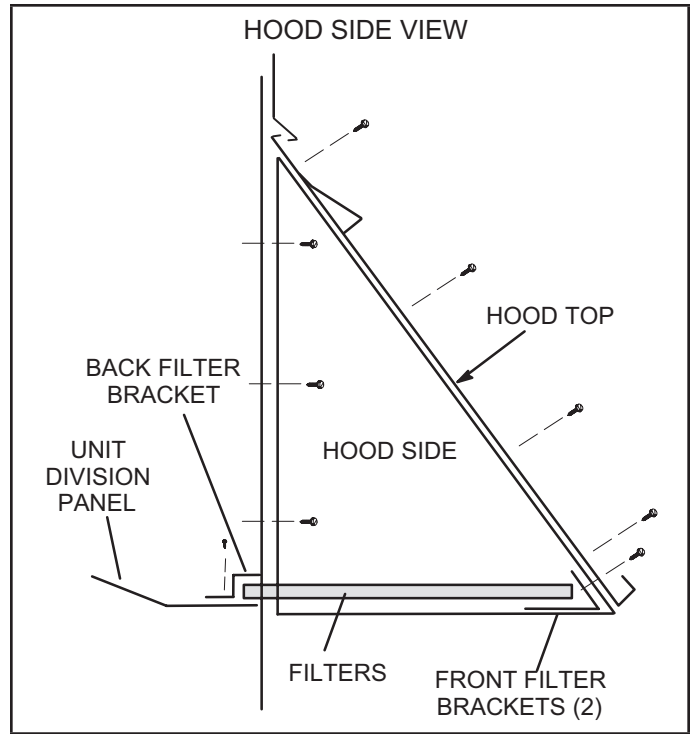

FIGURE 9

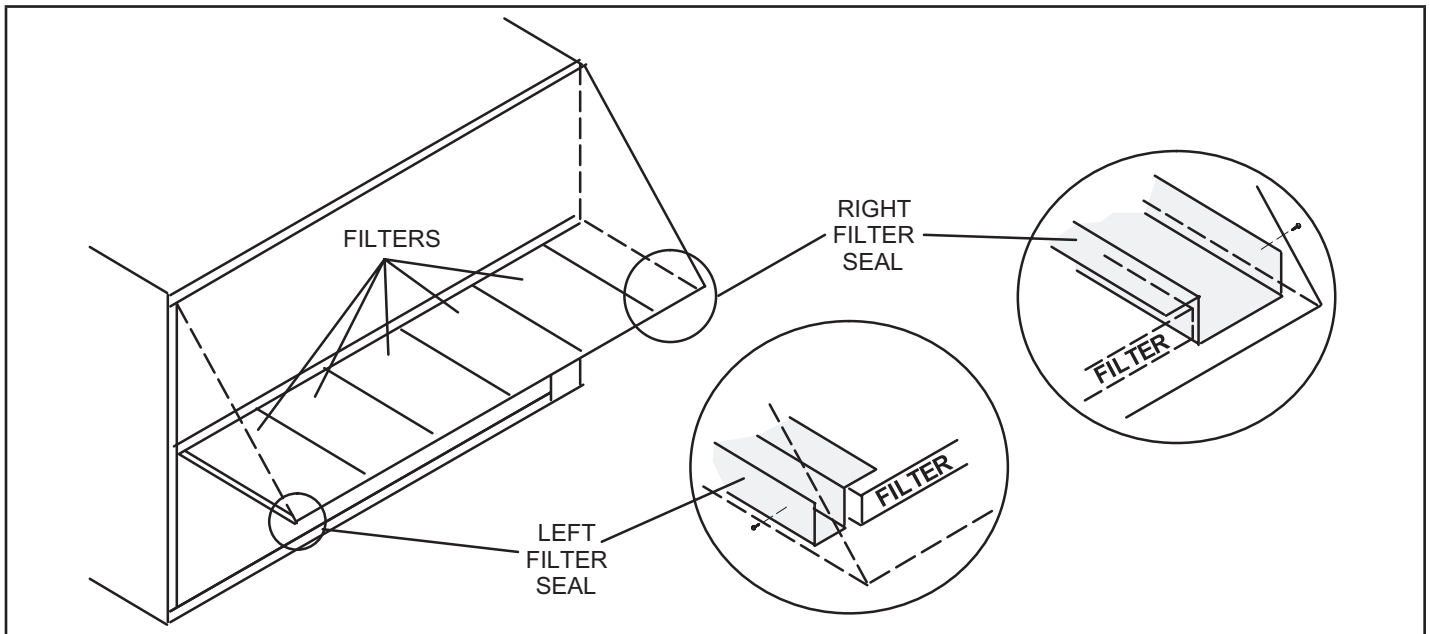

FIGURE 10

Electrical Connections

POWER SUPPLY

A-Wiring

Route field wiring in conduit between bottom power entry disconnect. See FIGURE 11. This does not supersede local codes or authorities having jurisdiction.

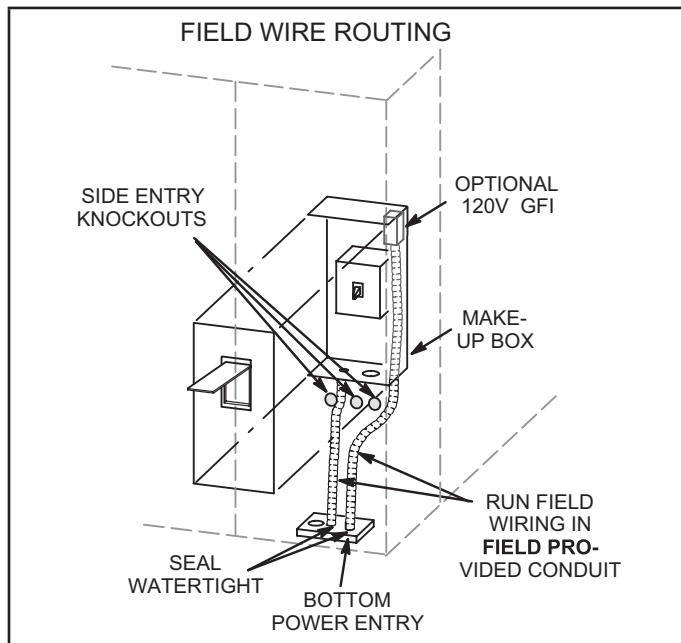

FIGURE 11

⚠ WARNING

Do not apply power or close disconnect switch until installation is complete. Refer to start-up directions. Refer closely to unit wiring diagram.

Refer to unit nameplate for minimum circuit ampacity and maximum fuse size.

- 1 - Units are factory-wired for 230/460/575V supply. For 208V supply, remove the insulated terminal cover from the 208V terminal on the control transformer. Move the wire from the transformer 230V terminal to the 208V terminal. Place the insulated terminal cover on the unused 230V terminal.
- 2 - Route power through the bottom power entry area and connect to line side of unit disconnect, circuit breaker or terminal block. See unit wiring diagram.
- 3 - *Units with optional 120V GFCI Outlet* - Route and connect separate 120V wiring to GFCI outlets which do not have factory-installed wiring. Route field wiring in conduit between bottom power entry and GFCI. See FIGURE 11.

B-Unbalanced Three-Phase Voltage - VFD Units Only

Units equipped with an optional inverter (VFD) are designed to operate on balanced, three-phase power. Operating units on unbalanced three-phase power will reduce

the reliability of all electrical components in the unit. Unbalanced power is a result of the power delivery system supplied by the local utility company.

Factory-installed inverters are sized to drive blower motors with an equivalent current rating using balanced three-phase power. When unbalanced three-phase power is supplied; the installer must replace the existing factory-installed inverter with an inverter that has a higher current rating to allow for the imbalance. Use TABLE 3 to determine the appropriate replacement inverter.

TABLE 3
INVERTER UP-SIZING

Factory-Installed Inverter HP	Replacement Inverter HP
2	5
3	7-1/2
5	10
7-1/2	15*
10	20*

*Replace the existing mounting plate.

CONTROL WIRING

A-Thermostat Location

Room thermostat mounts vertically on a standard 2" X 4" handy box or on any non-conductive flat surface.

Locate thermostat approximately 5 feet (1524 mm) above the floor in an area with good air circulation at average temperature. Avoid locating the room thermostat where it might be affected by:

- Drafts or dead spots behind doors and in corners
- Hot or cold air from ducts
- Radiant heat from sun or appliances
- Concealed pipes and chimneys

B-Wire Routing

Route thermostat cable or wires from subbase through knockout provided in unit. For thermostat wire runs up to 60 feet, use 18 gauge wire. For 60 to 90 feet runs, use 16 gauge wire.

IMPORTANT - Unless field thermostat wires are rated for maximum unit voltage, they must be routed away from line voltage wiring.

C-Wiring Connections

The Unit Controller will operate the unit from a thermostat or zone sensor based on the System Mode. The default System Mode is the thermostat mode. Refer to the Unit Controller Setup Guide to change the System Mode.

- 1 - Default Thermostat Mode - The Unit Controller will operate two stages of heating and cooling based on thermostat demands. Install thermostat assembly in accordance with instructions provided with thermostat. See FIGURE 12 for field wiring and wiring diagrams on unit.

IMPORTANT - Terminal connections at the wall plate or subbase must be made securely. Loose control wire connections may result in intermittent operation.

2 - Zone Sensor Mode - The Unit Controller will operate heating and cooling based on the Unit Controller internal setpoints and the temperature for the A2 zone sensor. An optional Network

Control Panel (NCP) can also be used to provide setpoints. A thermostat or return air sensor can be used as a back-up mode. Make zone sensor wiring connections as shown in FIGURE 13.

NOTE - Install sensor and make communication wiring connections as shown in literature provided with sensor.

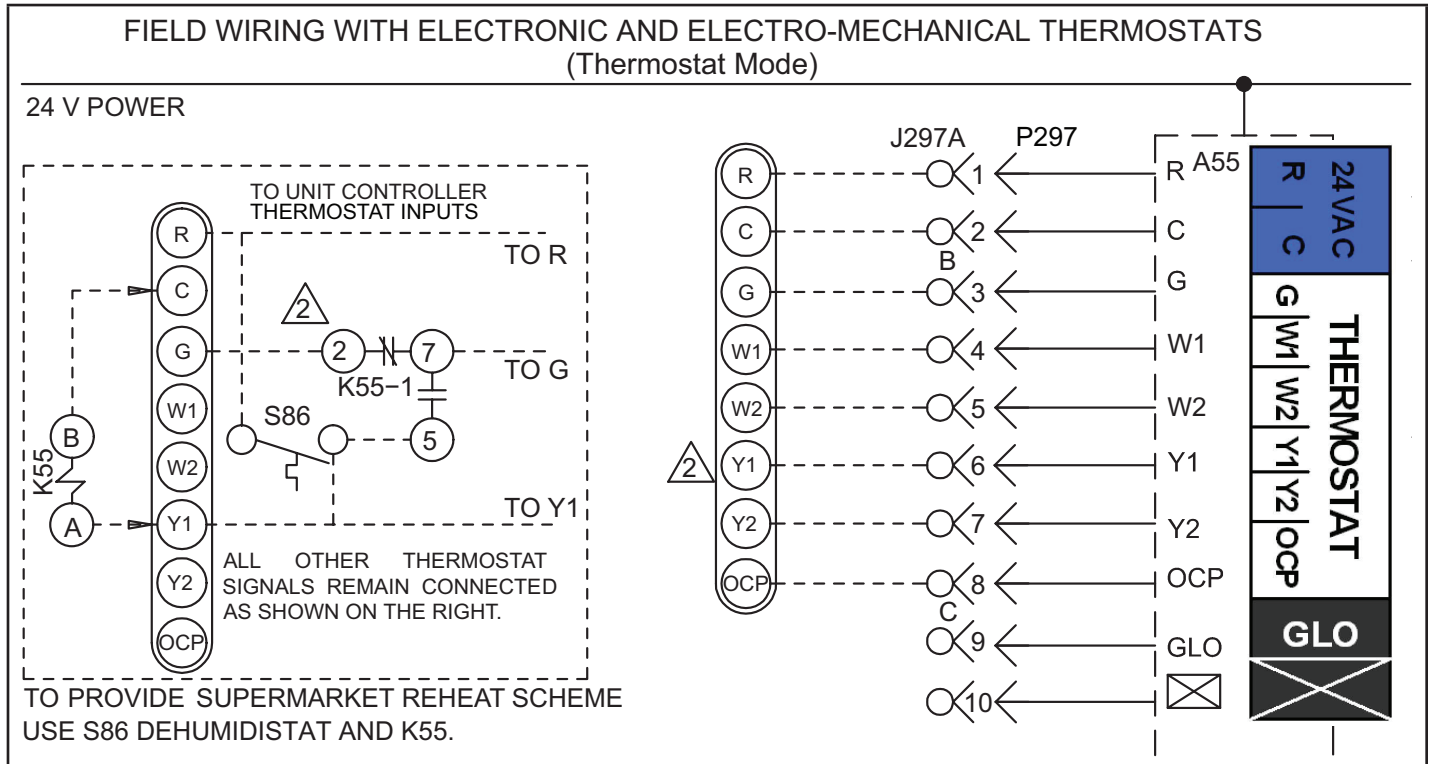

FIGURE 12

CONTROL WIRING (continued)

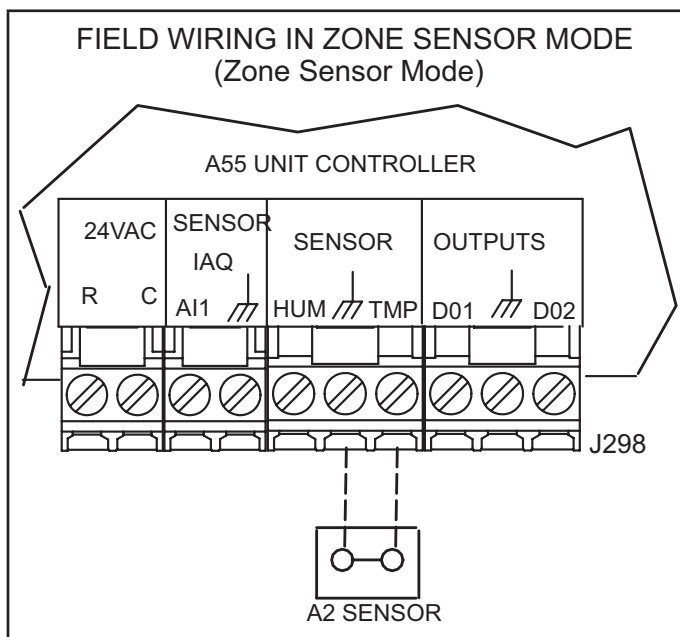

FIGURE 13

3 - Third Party Zoning - The Unit Controlling will operate up to four stages of heating and cooling

based on a third-party zoning system. Only 4 inputs are required to control the rooftop unit: G (blower enable), OCP (occupied), Y1 (enables discharge cooling) and W1 (enables discharge heating). Make wiring connections as shown in FIGURE 14.

D-Hot Gas Reheat

- 1 - Install humidity sensor in accordance with instructions provided with sensor. A DCC input may be used to initiate dehumidification instead of a sensor.
- 2 - Make wiring connections as shown in FIGURE 12 for Thermostat Mode or FIGURE 13 for Zone Sensor Mode. In addition, connect either a humidity sensor or a dehumidification input. See FIGURE 15 or FIGURE 16 for humidity sensor wiring or FIGURE 17 for dehumidification input wiring.

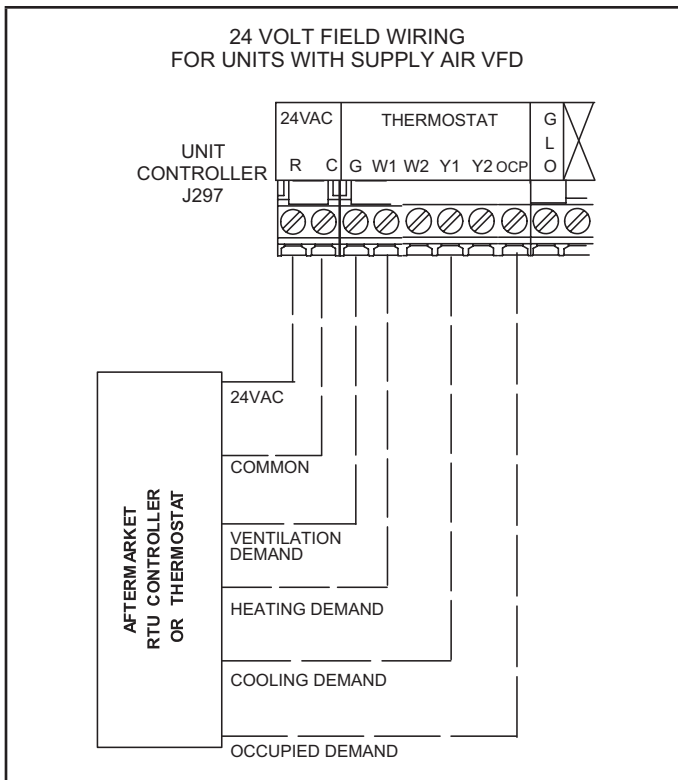

FIGURE 14

Humidity Sensor Cable Applications

Wire runs of 50 feet (15240 mm) or less:

Use two separate shielded cables containing 20AWG minimum, twisted pair conductors with overall shield. Belden type 8762 or 88760 (plenum) or equivalent. Connect both cable shield drain wires to the Unit Controller as shown in FIGURE 15.

Wire runs of 150 feet (45720 mm) or less:

Use two separate shielded cables containing 18AWG minimum, twisted pair conductors with overall shield. Belden type 8760 or 88760 (plenum) or equivalent. Connect both cable shield drain wires to the Unit Controller as shown in FIGURE 15.

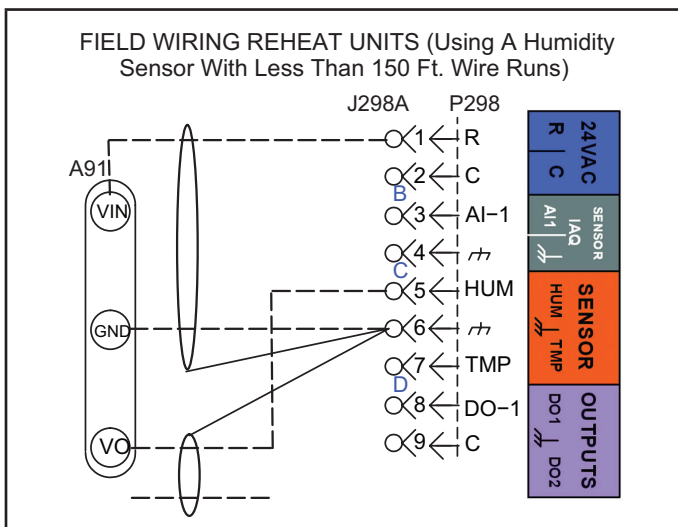

FIGURE 15

Wire runs over 150 feet (45720 mm):

Use a local, isolated 24VAC transformer such as Lennox cat #18M13 (20VA minimum) to supply power to RH sensor as shown in FIGURE 16. Use two shielded cables containing 20AWG minimum, twisted pair conductors with overall shield. Belden type 8762 or 88760 (plenum) or equivalent.

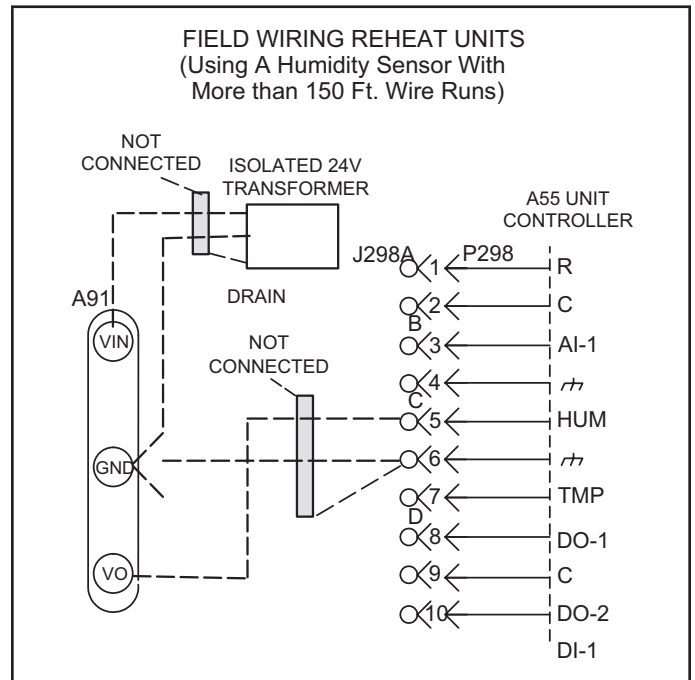
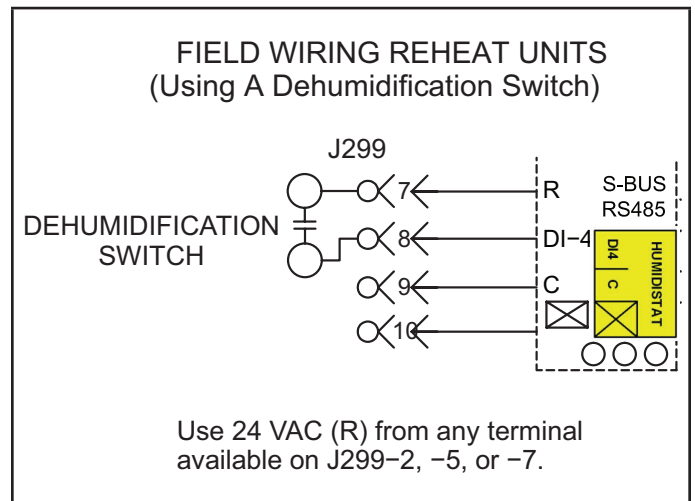

FIGURE 16



Use 24 VAC (R) from any terminal available on J299-2, -5, or -7.

FIGURE 17

Mobile Service App

Setup and configure each rooftop unit using the mobile service app (Android or iOS devices supported).

A-Mobile Device Requirements

- Bluetooth connection.
- Android hardware requires 2GB RAM and a 2Ghz core processor. Tablets are supported.
- The app is available for both iOS 11.0 or higher (App Store) and Android 9.0 or higher (Google Play).

B-Download the App

Use your mobile device to scan the QR code from the cover page and download the mobile service app to your mobile device.

C-Pair the App to the Unit Controller

- 1 - Apply power to the unit and wait until the Unit Controller has booted-up (approximately two minutes).
- 2 - Press and hold the pair button for five seconds. See FIGURE 19.
- 3 - The unit (or list of units) will appear; select the appropriate unit. When the app code matches the four-character code on the Unit Controller display, the unit is paired (within 10 seconds). Note the following:
 - The app will list the units by signal strength; the RTU name will be displayed.
 - Once paired, the RTU name, model number, serial number and firmware version will be displayed.

Please refer to the manufacturer's website for additional technical information and self-help support.

D-App Menus

See FIGURE 18 for the menu overview. Follow the app prompts in the Install, Network Integration, and Test and Balance menus. Verify the app is setup properly for the unit application (including the date and time). Refer to FIGURE 20, FIGURE 21, and FIGURE 22.

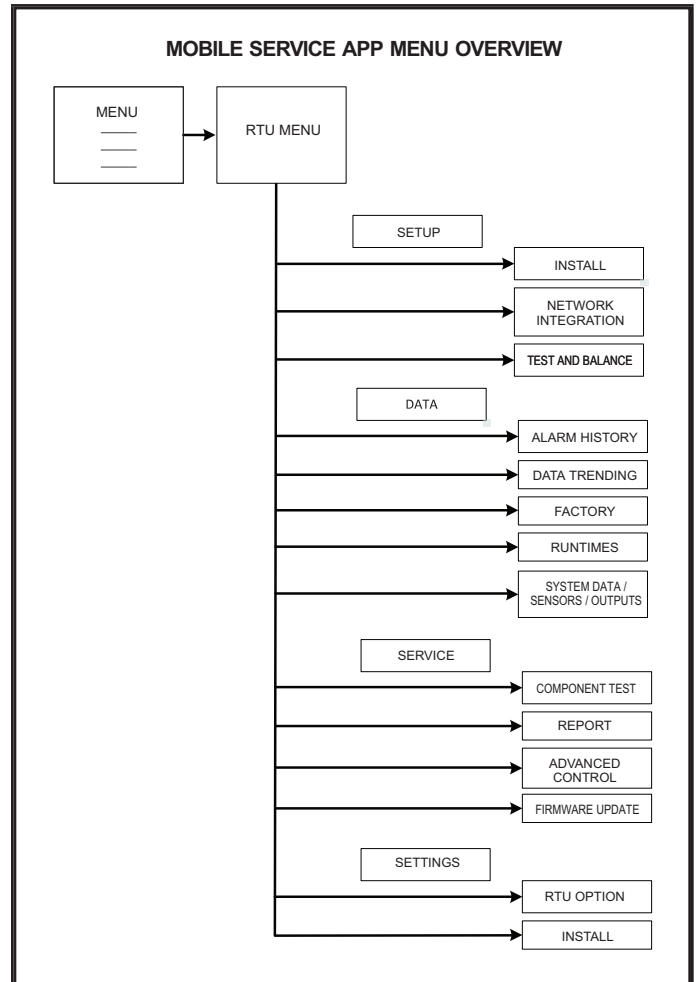

FIGURE 18

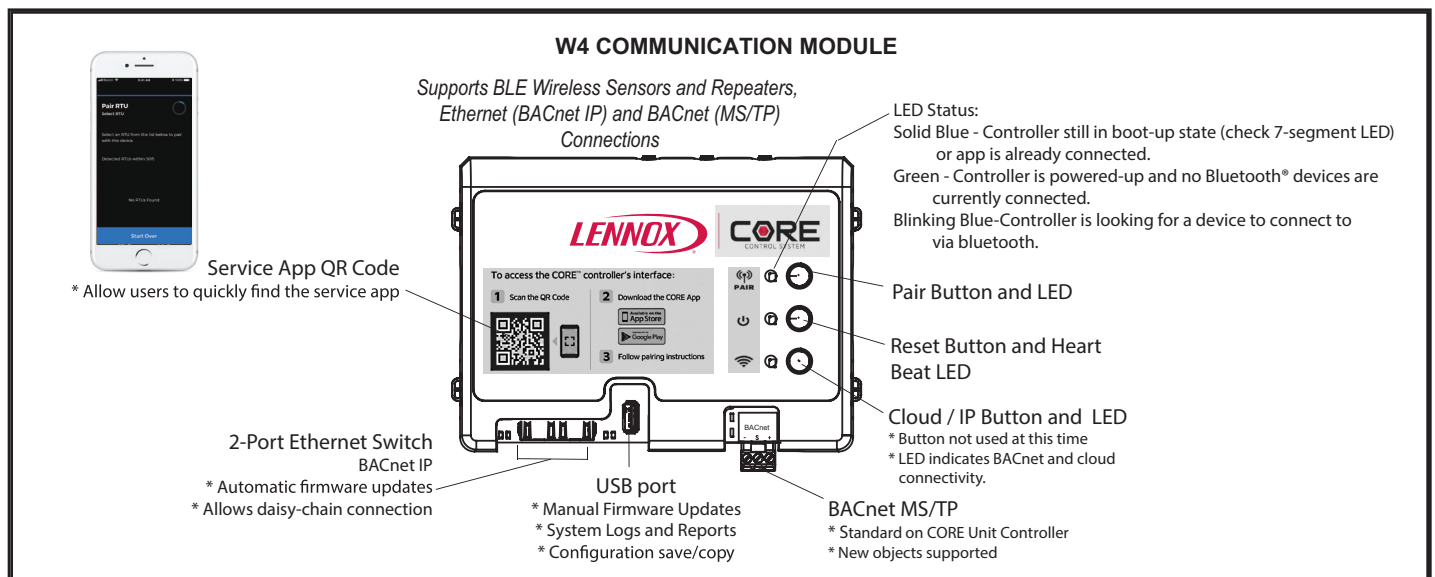

FIGURE 19

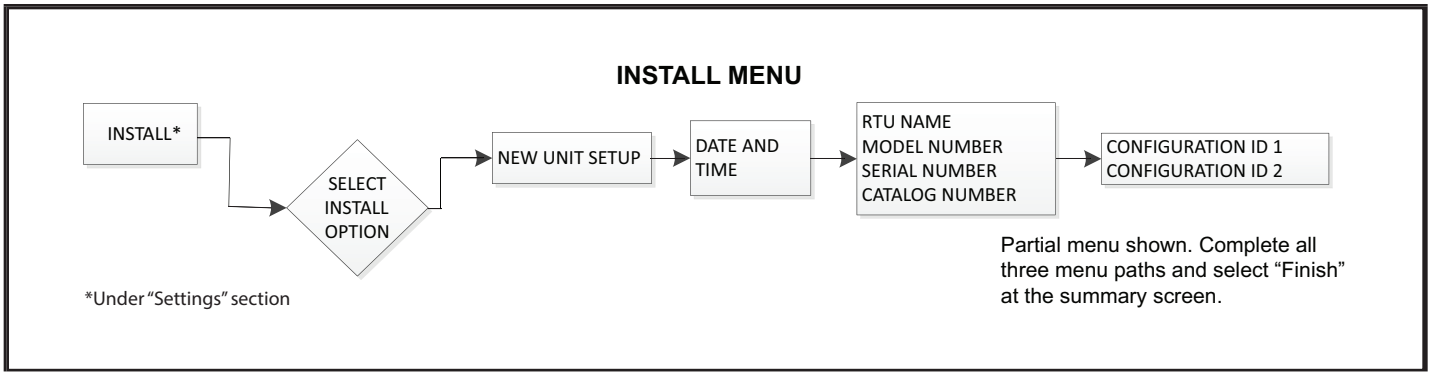

FIGURE 20

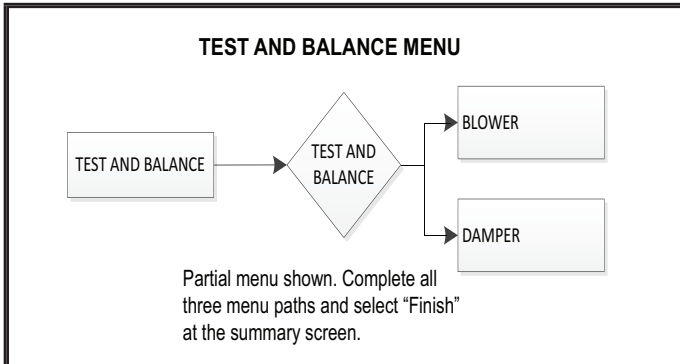

FIGURE 21

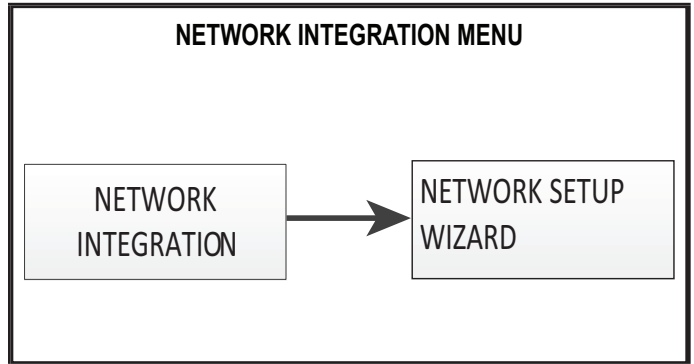

FIGURE 22

E-Unit Controller Components

See FIGURE 23 for Unit Controller components. See FIGURE 24 and TABLE 4 for pushbutton and LED functions.

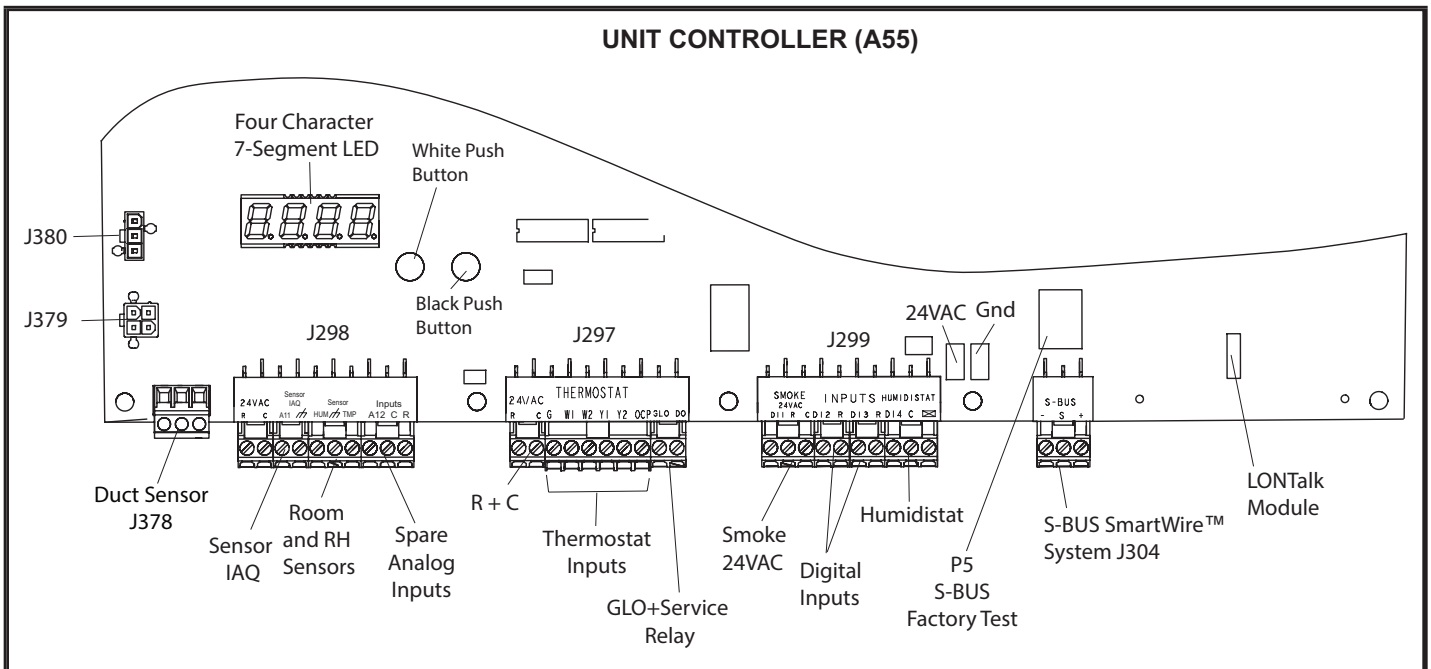

FIGURE 23

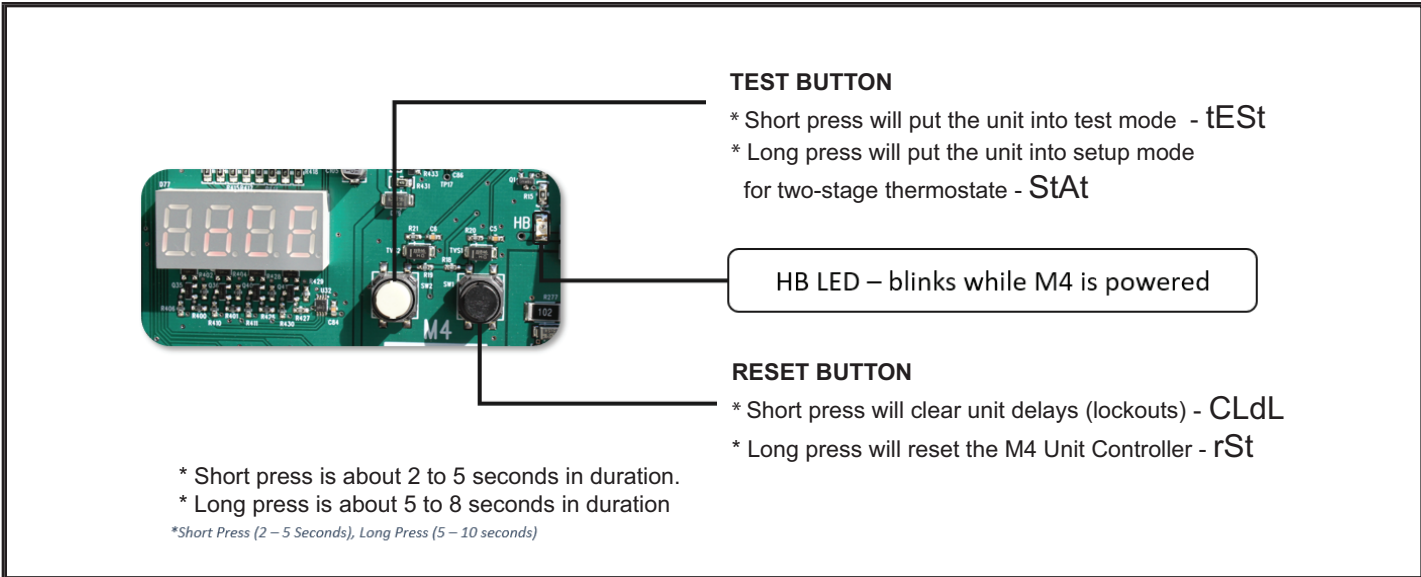

FIGURE 24

TABLE 4

UNIT CONTROLLER PUSHBUTTON CODES		
Code	Cause	Action
CLdL	Black Button: Short Press	Clear Delays
rSt	Black Button: Long Press	Reset
tEst	White Button: Short Press	TSTAT Test
StAt	White Button: Long Press (In Pre-Install state)	TSTAT Override
tEst	White Button: Long Press (NOT in Pre-Install State)	TSTAT Test

Short Press : 2 to 5 seconds.
 Long Press : 5 to 8 seconds.

Blower Operation and Adjustments

Supply Air Staged Units - The blower rotation will always be correct on units equipped with an inverter. Checking blower rotation is not a valid method of determining voltage phasing for incoming power.

Supply Air Staged Units and Units Equipped With Optional Voltage or Phase Detection - The Unit Controller checks the incoming power during start-up. If the voltage or phase is incorrect, the Unit Controller will display an alarm and the unit will not start.

A-Blower Operation

Refer to the Unit Controller Setup Guide to energize blower. Use this mobile service app menu:

SERVICE > TEST > BLOWER

Instructions provided with the thermostat may also be used to initiate blower only (G) demand. Unit will cycle on thermostat demand. The following steps apply to applications using a typical electro-mechanical thermostat.

- 1 - Blower operation is manually set at the thermostat subbase fan switch. With fan switch in **ON** position, blowers will operate continuously.
- 2 - With fan switch in **AUTO** position, the blowers will cycle with demand. Blowers and entire unit will be off when system switch is in **OFF** position.

⚠ IMPORTANT

Three Phase Scroll Compressor Voltage Phasing

Three phase scroll compressors must be phased sequentially to ensure correct compressor and blower* rotation and operation. Compressor and blower are wired in phase at the factory. Power wires are color-coded as follows: line 1-red, line 2-yellow, line 3-blue.

- 1- Observe suction and discharge pressures and blower* rotation on unit start-up.
- 2- Suction pressure must drop, discharge pressure must rise, and blower* rotation must match rotation marking.

If pressure differential is not observed or blower* rotation is not correct:

- 3- Disconnect all remote electrical power supplies.
- 4- Reverse any two field-installed wires connected to the line side of S48 disconnect or TB13 terminal strip. Do not reverse wires at blower contactor.
- 5- Make sure the connections are tight.

Discharge and suction pressures should operate at their normal start-up ranges.

*Supply air VFD motors should rotate in the correct direction; verify scroll compressor rotation separately. Contact technical support if the VFD blower is rotating incorrectly.

⚠ WARNING

- 1- Make sure that unit is installed in accordance with the installation instructions and applicable codes.
- 2- Inspect all electrical wiring, both field and factory-installed, for loose connections. Tighten as required.
- 3- Check to ensure that refrigerant lines do not rub against the cabinet or against other refrigerant lines.
- 4- Check voltage at disconnect switch. Voltage must be within range listed on nameplate. If not, consult power company and have voltage condition corrected before starting unit.
- 5- Make sure filters are new and in place before start-up.

B-Blower Access

- 1 - Disconnect jack/plug connector to blower motor. Also disconnect jack/plug connector heating limit switches on gas units.
- 2 - Remove screws on either side of blower assembly sliding base. See FIGURE 26.
- 3 - Pull base toward outside of unit.

C-Determining Unit CFM

IMPORTANT - Multi-staged supply air units are factory-set to run the blower at full speed when there is a blower (G) demand without a heating or cooling demand. Refer to the field-provided, design specified CFM for all modes of operation. Use the following procedure to adjust motor pulley to deliver the highest CFM called for in the design spec. See Inverter Start-Up section to set blower CFM for all modes once the motor pulley is set.

Variable Air Volume Units - Refer to the Variable Air Volume Start-Up section.

- 1 - The following measurements must be made with a dry indoor coil. Run blower (G demand) without a cooling demand. Measure the indoor blower shaft RPM. Air filters must be in place when measurements are taken.
- 2 - With all access panels in place, measure static pressure external to unit (from supply to return). Blower performance data is based on static pressure readings taken in locations shown in FIGURE 25.

NOTE - Static pressure readings can vary if not taken where shown.

- 3 - Referring to page 21, use static pressure and RPM readings to determine unit CFM. Use page 22 when installing units with any of the optional accessories listed.
- 4 - The blower RPM can be adjusted at the motor pulley. Loosen Allen screw and turn adjustable pulley clockwise to increase CFM. Turn counterclockwise to decrease CFM. See FIGURE 26. Do not exceed minimum and maximum number of pulley turns as shown in TABLE 5.

TABLE 5

MINIMUM AND MAXIMUM PULLEY ADJUSTMENT

Belt	Min. Turns Open	Max. Turns Open
A Section	No minimum	5
B Section	1*	6

*No minimum number of turns open when B belt is used on pulleys 6" O.D. or larger.

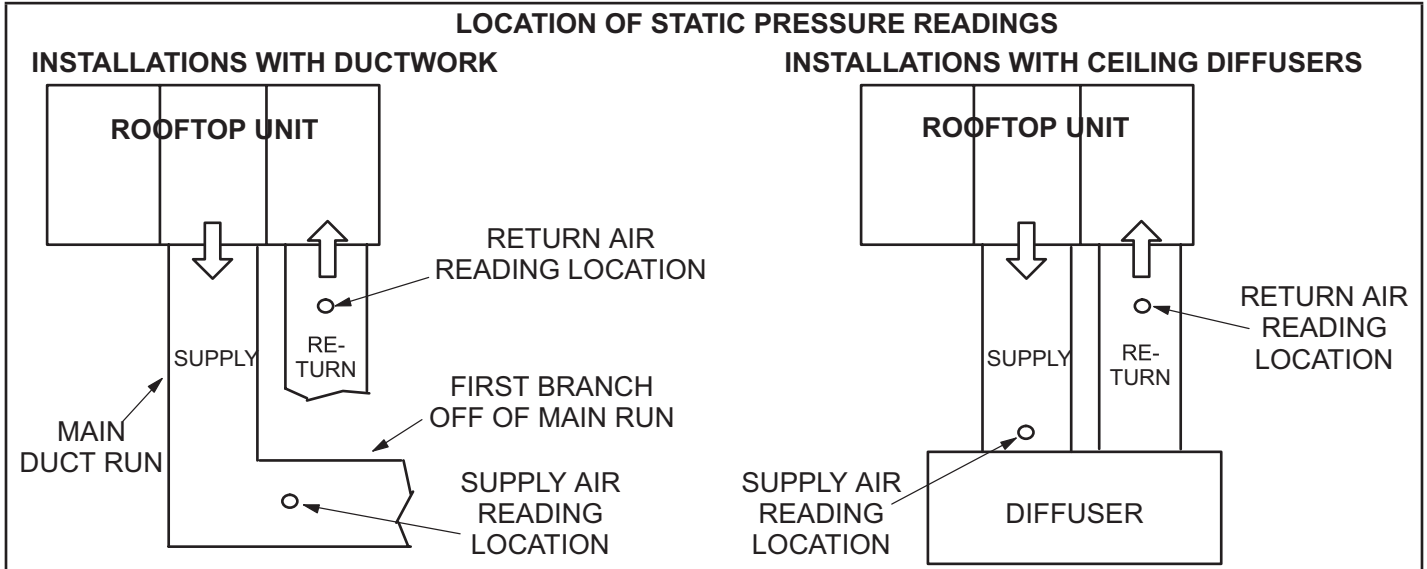

FIGURE 25

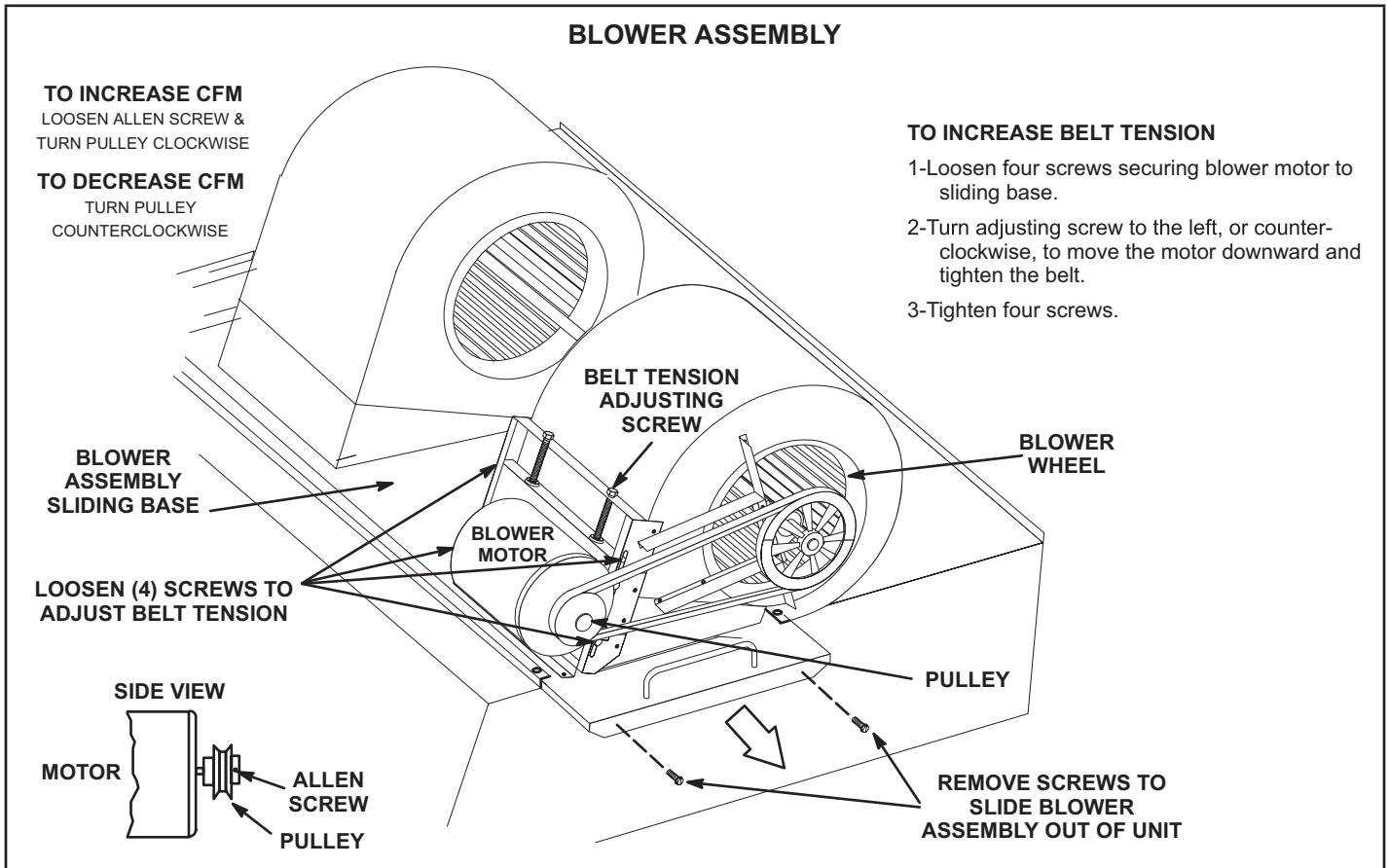

FIGURE 26

D-Blower Belt Adjustment

Maximum life and wear can be obtained from belts only if proper pulley alignment and belt tension are maintained. Tension new belts after a 24-48 hour period of operation. This will allow belt to stretch and seat into pulley grooves. Make sure blower and motor pulley are aligned. See FIGURE 27.

- 1 - Loosen four screws securing blower motor to sliding base. See FIGURE 26.
- 2 - To increase belt tension -
Turn belt tension adjusting screw to the left, or counterclockwise, to tighten the belt. This increases the distance between the blower motor and the blower housing.
To loosen belt tension -
Turn the adjusting screw to the right, or clockwise to loosen belt tension.
- 3 - Tighten four screws securing blower motor to sliding base once adjustments have been made.

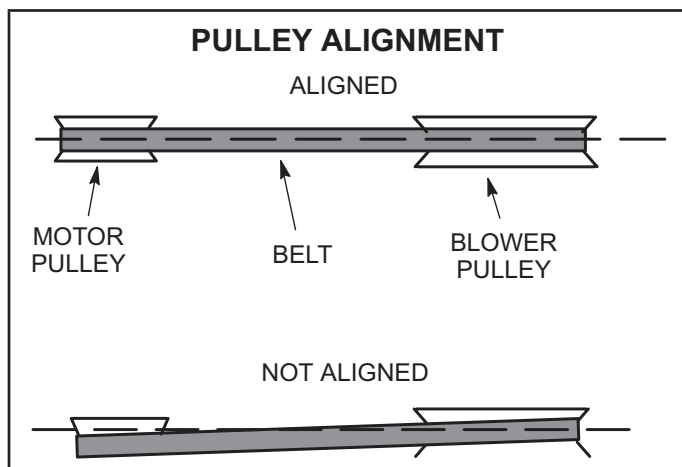

FIGURE 27

E-Check Belt Tension

Overtensioning belts shortens belt and bearing life. Check belt tension as follows:

- 1 - Measure span length X. See FIGURE 28.

- 2 - Apply perpendicular force to center of span (X) with enough pressure to deflect belt 1/64" for every inch of span length or 1.5mm per 100mm of span length.

Example: Deflection distance of a 40" span would be 40/64" or 5/8".

Example: Deflection distance of a 400mm span would be 6mm.

- 3 - Measure belt deflection force. For a used belt, the deflection force should be 5 lbs. (35kPa). A new belt deflection force should be 7 lbs. (48kPa).

A force below these values indicates an undertensioned belt. A force above these values indicates an overtensioned belt.

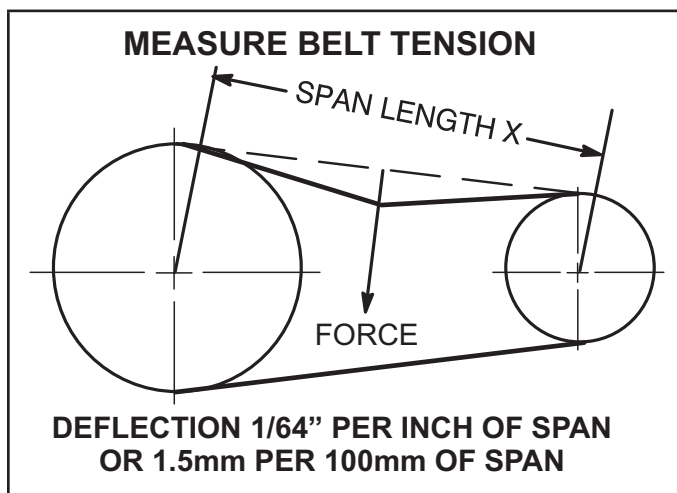

FIGURE 28

F-Field-Furnished Blower Drives

For field-furnished blower drives, use page 21 to determine BHP and RPM required. Reference page 23 to determine the manufacturer's model number.

G-Minimum Airflow For Optional Electric Heat

Electric Heat kW	Minimum CFM
30	8000
45	8000
60	8000
90	8000

BLOWER DATA

BLOWER TABLE INCLUDES RESISTANCE FOR BASE UNIT ONLY WITH DRY INDOOR COIL & AIR FILTERS IN PLACE

FOR ALL UNITS ADD:

- 1 - Wet indoor coil air resistance of selected unit.
- 2 - Any factory installed options air resistance (electric heat, economizer, etc.)
- 3 - Any field installed accessories air resistance (electric heat, duct resistance, diffuser, etc.)

Then determine from blower table blower motor output and drive required.

See page 21 for wet coil and option/accessory air resistance data.

See page 21 for factory installed drive kit specifications.

MINIMUM AIR VOLUME REQUIRED FOR USE WITH OPTIONAL ELECTRIC HEAT

All units require 8,000 cfm minimum air with electric heat.

Air Volume cfm	TOTAL STATIC PRESSURE - Ln. w.g.																											
	0.20		0.40		0.60		0.80		1.00		1.20		1.40		1.60		1.80		2.00		2.20		2.40		2.60			
	RPM	BHP	RPM	BHP	RPM	BHP	RPM	BHP	RPM	BHP	RPM	BHP	RPM	BHP	RPM	BHP	RPM	BHP	RPM	BHP	RPM	BHP	RPM	BHP	RPM	BHP	RPM	BHP
4000	372	0.26	433	0.65	497	0.99	565	1.27	630	1.54	687	1.79	738	2.04	784	2.3	824	2.56	861	2.82	897	3.1	932	3.4	968	3.66	974	4.01
4500	382	0.41	441	0.79	506	1.12	574	1.41	638	1.69	694	1.95	744	2.22	790	2.5	831	2.77	868	3.05	903	3.35	938	3.66	974	3.93	980	4.3
5000	392	0.56	451	0.93	516	1.25	584	1.55	646	1.85	702	2.12	751	2.41	796	2.7	837	3	874	3.3	909	3.61	944	3.93	980	4.22	987	4.6
5500	402	0.73	462	1.08	527	1.4	594	1.72	655	2.02	710	2.31	758	2.61	802	2.92	843	3.24	880	3.56	916	3.88	951	4.22	987	4.52	994	4.91
6000	414	0.89	473	1.24	539	1.56	605	1.9	665	2.21	718	2.51	766	2.83	809	3.16	850	3.51	887	3.84	922	4.18	957	4.52	994	4.85	1001	5.24
6500	426	1.07	486	1.41	551	1.74	616	2.1	675	2.42	727	2.73	774	3.07	817	3.43	857	3.8	894	4.15	929	4.49	964	4.85	1001	5.19	1008	5.59
7000	439	1.26	499	1.6	565	1.93	628	2.31	685	2.64	737	2.97	782	3.34	825	3.72	864	4.11	901	4.48	937	4.83	971	5.19	1008	5.56	1016	5.97
7500	453	1.46	513	1.79	579	2.14	641	2.55	696	2.88	747	3.24	792	3.63	833	4.04	872	4.45	909	4.83	945	5.2	979	5.56	1016	5.96	1025	6.37
8000	467	1.66	528	2	593	2.38	653	2.81	708	3.15	757	3.53	801	3.95	843	4.39	881	4.82	918	5.22	953	5.59	988	5.96	1025	6.39	1034	6.81
8500	483	1.88	544	2.22	608	2.65	667	3.1	720	3.44	768	3.85	812	4.3	852	4.78	890	5.22	927	5.63	962	6.01	997	6.39	1034	6.85	1044	7.28
9000	499	2.11	561	2.47	624	2.95	681	3.41	733	3.76	780	4.2	823	4.69	862	5.19	900	5.65	936	6.07	972	6.46	1007	6.85	1044	7.34	1055	7.78
9500	516	2.36	578	2.75	640	3.26	696	3.73	746	4.1	792	4.58	834	5.11	873	5.64	910	6.12	946	6.54	982	6.93	1018	7.34	1055	7.86	1066	8.32
10,000	534	2.64	596	3.06	657	3.6	711	4.07	760	4.48	805	5	845	5.57	884	6.12	921	6.61	957	7.03	992	7.43	1028	7.86	1066	8.4	1077	8.89
10,500	553	2.93	615	3.39	674	3.95	727	4.44	775	4.9	817	5.46	857	6.06	895	6.62	932	7.12	967	7.55	1003	7.96	1039	8.4	1077	8.98	1089	9.49
11,000	572	3.24	634	3.74	692	4.31	744	4.83	789	5.35	830	5.95	869	6.58	907	7.16	943	7.65	978	8.09	1013	8.51	1050	8.98	1089	9.59	1101	10.12
11,500	592	3.58	653	4.12	711	4.7	760	5.27	803	5.85	843	6.49	881	7.13	918	7.71	954	8.21	989	8.65	1025	9.1	1062	9.59	1101	10.22	1111	11.26
12,000	613	3.95	674	4.53	729	5.14	776	5.75	818	6.39	857	7.06	894	7.71	930	8.3	965	8.8	1000	9.25	1036	9.71	1073	10.22	1111	11.36	1121	12.41
12,500	635	4.37	695	4.98	748	5.62	792	6.29	832	6.98	870	7.67	906	8.33	941	8.91	976	9.42	1011	9.87	1048	10.35	1084	10.84	1121	11.94	1131	13.56
13,000	657	4.83	715	5.5	766	6.18	808	6.89	847	7.61	883	8.32	918	8.98	953	9.56	988	10.06	1023	10.36	1060	10.84	1096	11.36	1131	12.52	1141	14.71
13,500	680	5.35	736	6.06	784	6.78	824	7.53	861	8.29	896	9	930	9.66	965	10.24	1000	10.72	1035	11.06	1072	11.56	1108	12.06	1141	13.10	1151	16.06
14,000	704	5.92	757	6.67	801	7.44	839	8.23	875	9	909	9.72	943	10.38	978	10.92	1013	11.48	1048	11.96	1084	12.46	1120	12.96	1151	13.70	1161	17.56
14,500	727	6.55	777	7.34	818	8.16	854	8.97	889	9.75	922	10.48	956	11.06	990	11.66	1025	12.12	1060	12.56	1096	13.06	1134	13.56	1161	14.30	1171	19.06
15,000	750	7.23	797	8.07	834	8.92	868	9.75	902	10.54	935	11.26	968	12.12	1000	12.86	1035	13.62	1070	14.06	1106	14.56	1144	15.06	1171	15.90	1181	20.56

BLOWER DATA

FACTORY INSTALLED BELT DRIVE KIT SPECIFICATIONS

Motor Efficiency	Nominal hp	Maximum hp	Drive Kit Number	RPM Range
Standard	5	5.75	5	660 - 810
Standard	5	5.75	6	770 - 965
Standard	5	5.75	7	570 - 720
Standard	5	5.75	8	480 - 630
Standard	5	5.75	9	410 - 535
Standard	7.5	8.63	3	715 - 880
Standard	7.5	8.63	4	770 - 965
Standard	10	11.50	1	740 - 895
Standard	10	11.50	2	870 - 1045

NOTES

Using total air volume and system static pressure requirements determine from blower performance tables rpm and motor output required. Maximum usable output of motors furnished are shown. In Canada, nominal motor output is also maximum usable motor output. If motors of comparable output are used, be sure to keep within the service factor limitations outlined on the motor nameplate.

For VFD applications, nominal motor output is also maximum usable motor output.

FACTORY INSTALLED OPTIONS/FIELD INSTALLED ACCESSORY AIR RESISTANCE

Air Volume cfm	Wet Indoor Coil in. w.g.	Gas Heat Exchanger			Electric Heat in. w.g.	Economizer in. w.g.	Filters		Horizontal Roof Curb in. w.g.
		Standard Heat	Medium Heat	High Heat			MERV 8	MERV 13	
		in. w.g.	in. w.g.	in. w.g.			in. w.g.	in. w.g.	
4000	0.07	0.08	0.08	0.11	0.01	0.00	0.00	0.00	0.04
4500	0.09	0.09	0.10	0.13	0.01	0.00	0.00	0.00	0.05
5000	0.10	0.10	0.12	0.15	0.01	0.00	0.00	0.00	0.06
5500	0.13	0.11	0.14	0.17	0.02	0.01	0.00	0.01	0.07
6000	0.14	0.12	0.16	0.19	0.02	0.01	0.00	0.02	0.08
6500	0.16	0.13	0.18	0.21	0.02	0.01	0.01	0.02	0.09
7000	0.18	0.14	0.20	0.24	0.03	0.02	0.01	0.03	0.10
7500	0.20	0.15	0.21	0.25	0.03	0.02	0.01	0.04	0.11
8000	0.22	0.17	0.24	0.28	0.03	0.02	0.01	0.04	0.13
8500	0.24	0.20	0.27	0.31	0.04	0.03	0.01	0.04	0.15
9000	0.27	0.22	0.29	0.34	0.04	0.04	0.01	0.04	0.17
9500	0.29	0.24	0.32	0.38	0.05	0.04	0.02	0.06	0.19
10000	0.31	0.27	0.36	0.42	0.05	0.05	0.02	0.06	0.21
10500	0.33	0.30	0.40	0.46	0.06	0.06	0.02	0.06	0.24
11000	0.36	0.33	0.43	0.50	0.06	0.07	0.02	0.07	0.27
11500	0.39	0.37	0.48	0.55	0.07	0.08	0.02	0.08	0.30
12000	0.41	0.40	0.52	0.60	0.07	0.10	0.02	0.08	0.33
12500	0.44	0.44	0.57	0.65	0.08	0.11	0.03	0.10	0.37
13000	0.47	0.48	0.61	0.70	0.08	0.13	0.03	0.10	0.40
13500	0.49	0.53	0.67	0.76	0.09	0.14	0.03	0.11	0.44
14000	0.52	0.57	0.72	0.82	0.10	0.16	0.03	0.12	0.49
14500	0.55	0.62	0.78	0.89	0.10	0.18	0.04	0.13	0.53
15000	0.58	0.68	0.84	0.95	0.11	0.21	0.04	0.13	0.58

**TABLE 6
MANUFACTURER'S NUMBERS (60 HZ)**

Drive No.	DRIVE COMPONENTS							
	ADJUSTABLE SHEAVE		FIXED SHEAVE		BELTS		SPLIT BUSHING	
	Supplier No.	OEM Part No.	Supplier No.	OEM Part No.	Supplier No.	OEM Part No.	Supplier No.	OEM Part No.
1	1VP71x1-3/8	100239-06	BK140H	100788-13	BX78	100245-44	H - 1-3/16	105616-02
2	1VP71x1-1/8	100239-06	BK120H	100788-07	BX75	31K9801	H - 1-3/16	105616-02
3	1VP65x1-3/8	78M7101	BK130H	100788-08	BX75	31K9801	H - 1-3/16	105616-02
4	1VP60x1-3/8	78L5501	BK110H	100788-06	BX71	31K9701	H - 1-3/16	105616-02
5	1VP56x1-1/8	P-8-1492	BK120H	100788-07	BX71	31K9701	H - 1-3/16	105616-02
6	1VP60x1-1/8	41C1301	BK110H	100788-06	BX70	31K9601	H - 1-3/16	105616-02
7	1VP50x1-1/8	P-8-1977	BK120H	100788-07	BX70	31K9601	H - 1-3/16	105616-02
8	1VP44x1-1/8	36C0701	BK120H	100788-07	BX70	31K9601	H - 1-3/16	105616-02
9	1VP44x1-1/8	36C0701	BK140H	100788-13	BX73	100245-41	H - 1-3/16	105616-02

Refrigerant Leak Detection System

A-System Test

- 1 - Initiate Refrigerant Leak Detection System Test by using the following mobile service app menu path:

RTU MENU > COMPONENT TEST > LEAK DETECTION > START TEST

- 2 - Ensure that indoor blower, outdoor fan, and combustion air blower (LGT only) are energized.

Cooling Start-Up

IMPORTANT

Three Phase Scroll Compressor Voltage Phasing

Three phase scroll compressors must be phased sequentially to ensure correct compressor and blower* rotation. Compressor and blower are wires in phase at the factory. Power wires are color-coded as follows: line 1-red, line 2-yellow, line 3-blue.

- 1 - Observe suction and discharge pressures and blower* rotation on unit start-up.
- 2 - Suction pressure must drop, discharge pressure must rise, and blower* rotation must match rotation marking.

If pressure differential is not observed or blower* rotation is not correct:

- 3 - Disconnect all remote electrical power supplies.
- 4 - Reverse any two field-installed wires connected to the line side of S48 disconnect or TB13 terminal strip. Do not reverse wires at blower contactor.
- 5 - Make sure the connections are tight.

Discharge and suction pressures should operate at their normal start-up ranges.

*Supply air VFD motors should rotate in the correct direction; verify scroll compressor rotation separately. Contact technical support if the VFD blower is rotating incorrectly.

IMPORTANT - The crankcase heater must be energized for 24 hours before attempting to start compressor. Set thermostat so there is no demand to prevent compressors from cycling.

VFD Units - The blower rotation will always be correct on VFD units. Checking blower rotation is not a valid method of determining voltage phasing for incoming power.

VFD Units and Units Equipped with Optional Voltage or Phase Detection - The Unit Controller checks the incoming power during start-up. If the voltage or phase is incorrect, the Unit Controller will display an alarm and the unit will not start.

A-Preliminary Checks

- 1 - Make sure the unit is installed in accordance with the installation instructions and applicable codes.
- 2 - Inspect all electrical wiring, both field and factory-installed, for loose connections. Tighten as required.
- 3 - Check to ensure that refrigerant lines do not rub against the cabinet or against other refrigerant lines.
- 4 - Check voltage at disconnect switch. Voltage must be within range listed on nameplate. If not, consult power company and have voltage condition corrected before starting unit.
- 5 - Make sure filters are in place before start-up.

B-Start-Up

VFD Units - Refer to the Optional VFD Start-Up section.

- 1 - Initiate first and second stage cooling demands according to instructions provided with thermostat.
- 2 - First-stage thermostat demand will energize compressors 1 and 2. Second-stage thermostat demand will energize compressors 3 and 4. On units with an economizer, when outdoor air is acceptable, a first-stage demand will energize the economizer; a second-stage demand will energize compressors 1 and 2.

3 - Units contain four refrigerant circuits or systems. Evaporator and condenser coil refrigerant circuits 1 and 2 make up stage 1 cooling. Evaporator and condenser refrigerant circuits 3 and 4 make up stage 2 cooling. See FIGURE 29.

4 - Each refrigerant circuit is separately charged with R-454B refrigerant. See unit rating plate for correct amount of charge.

5 - Refer to Cooling Operation and Adjustment section for proper method to check refrigerant charge.

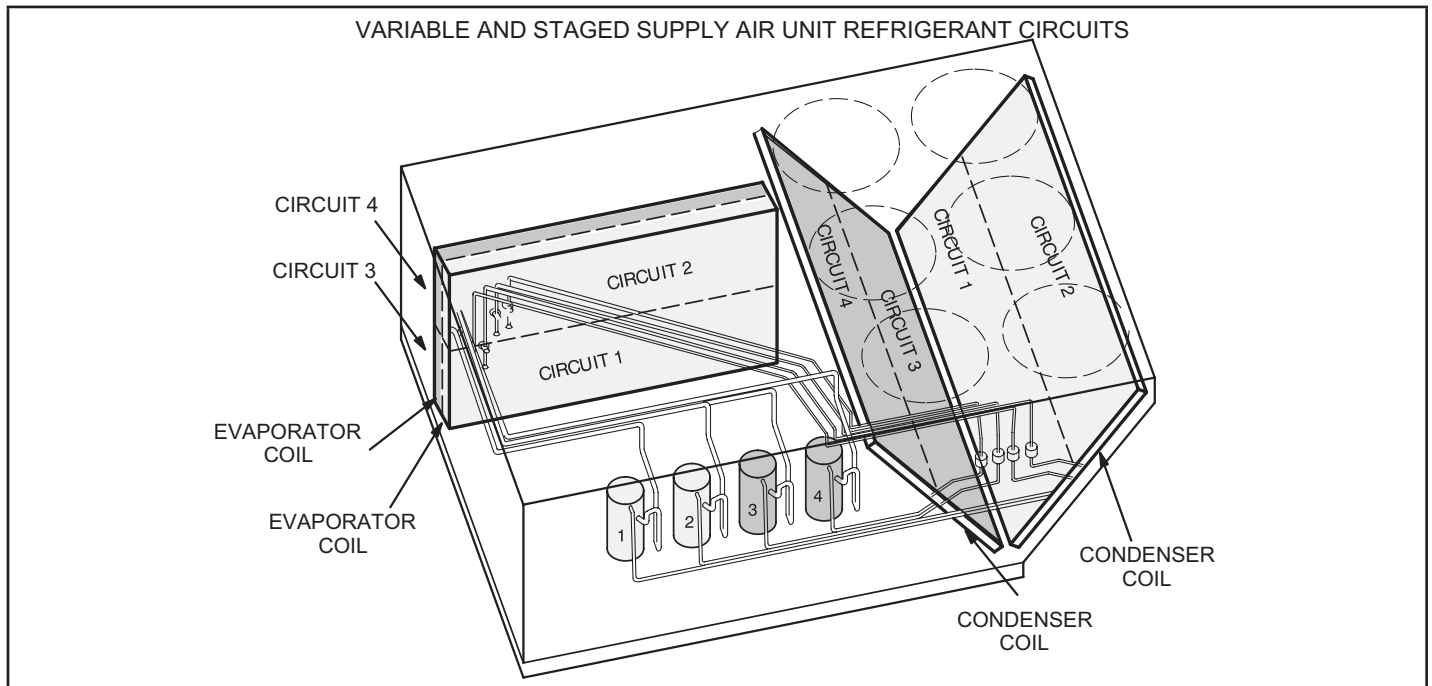

FIGURE 29

C-Refrigerant Charge and Check

WARNING - Do not exceed nameplate charge under any condition.

This unit is factory charged and should require no further adjustment. If the system requires additional refrigerant, reclaim the charge, evacuate the system, and add required nameplate charge.

NOTE - System charging is not recommended below 60°F (15°C). In temperatures below 60°F (15°C), the charge must be weighed into the system.

If weighing facilities are not available, or to check the charge, use the following procedure:

IMPORTANT - Charge unit in standard cooling mode.

- 1 - Make sure outdoor coil is clean. Attach gauge manifolds and operate unit at full CFM in cooling mode with economizer disabled until system stabilizes (approximately five minutes). Make sure all outdoor air dampers are closed.
- 2 - Check each system separately with all stages operating. Compare the normal operating pressures (see TABLE 7 through TABLE 8) to the pressures obtained from the gauges. Check unit components if there are significant differences.
- 3 - Measure the outdoor ambient temperature and the suction pressure. Refer to the appropriate circuit charging curve to determine the target liquid temperature.

NOTE - Pressures are listed for sea level applications.

- 4 - Use the same thermometer to accurately measure the liquid temperature (near the liquid service tap).
 - If measured liquid temperature is higher than the target liquid temperature, add refrigerant to the system.
 - If measured liquid temperature is lower than the target liquid temperature, recover some refrigerant from the system.
- 5 - Add or remove charge in increments. Allow the system to stabilize each time refrigerant is added or removed.
- 6 - Continue the process until measured liquid temperature agrees with the target liquid temperature. Do not go below the target liquid temperature when adjusting charge. Note that suction pressure can change as charge is adjusted.
- 7 - Example LGT/LCT302H Circuit 1: At 95°F outdoor ambient and a measured suction pressure of 128 psig, the target liquid temperature is 100°F. For a measured liquid temperature of 106°F, add charge in increments until measured liquid temperature agrees with the target liquid temperature.

Refrigerant Charge R-454B		
Unit	M _c (lbs)	M _c (kg)
LGT/LCT302 RH & No RH Stage 1	6.75	3.06
LGT/LCT302 RH & No RH Stage 2	6.50	2.95
LGT/LCT302 RH & No RH Stage 3	6.69	3.03
LGT/LCT302 RH & No RH Stage 4	6.81	3.09
LGT/LCT360 No RH Stage 1	6.38	2.89
LGT/LCT360 No RH Stage 2	6.81	3.09
LGT/LCT360 No RH Stage 3	6.63	3.01
LGT/LCT360 No RH Stage 4	6.38	2.89
LGT/LCT360 RH Stage 1	7.75	3.52
LGT/LCT360 RH Stage 2	7.50	3.40
LGT/LCT360 RH Stage 3	6.88	3.12
LGT/LCT360 RH Stage 4	6.75	3.06

In addition to conventional charging procedures, the following requirements shall be followed.

- Ensure that contamination of different refrigerants does not occur when using charging equipment. Hoses or lines shall be as short as possible to minimize the amount of refrigerant contained in them.
- Cylinders shall be kept in an appropriate position according to the instructions.
- Ensure that the unit is earth grounded prior to charging the system with refrigerant.
- Label the system when charging is complete (if not already).
- Extreme care shall be taken not to overfill the unit.

Prior to recharging the system, it shall be pressure-tested with the appropriate purging gas. The system shall be leak-tested on completion of charging but prior to commissioning. A follow up leak test shall be carried out prior to leaving the site.

- When removing refrigerant from a system, either for servicing or decommissioning, it is recommended good practice that all refrigerants are removed safely.
- When transferring refrigerant into cylinders, ensure that only appropriate refrigerant recovery cylinders are employed. Ensure that the correct number of cylinders for holding the total system charge is available. All cylinders to be used are designated for the recovered refrigerant and labelled for that

refrigerant (i. e. special cylinders for the recovery of refrigerant). Cylinders shall be complete with pressure-relief valve and associated shut-off valves in good working order. Empty recovery cylinders are evacuated and, if possible, cooled before recovery

- The recovery equipment shall be in good working order with a set of instructions concerning the equipment that is at hand and shall be suitable for the recovery of all appropriate refrigerants including, when applicable, flammable refrigerants. In addition, a set of calibrated weighing scales shall be available and in good working order. Hoses shall be complete with leak-free disconnect couplings and in good condition. Before using the recovery machine, check that it is in satisfactory working order, has been properly maintained and that any associated electrical components are sealed to prevent ignition in the event of a refrigerant release. Consult manufacturer if in doubt.
- The recovered refrigerant shall be returned to the refrigerant supplier in the correct recovery cylinder, and the relevant waste transfer note arranged. Do not mix refrigerants in recovery units and especially
- If compressors or compressor oils are to be removed, ensure that they have been evacuated to an acceptable level to make certain that flammable refrigerant does not remain within the lubricant. The evacuation process shall be carried out prior to returning the compressor to the suppliers. Only electric heating to the compressor body shall be employed to accelerate this process. When oil is drained from a system, it shall be carried out safely.

NOTE - *System charging is not recommended below 60°F (15°C). In temperatures below 60°F (15°C), the charge must be weighed into the system.*

TABLE 7
LGT/LCT302H No Reheat & Reheat Normal Operating Pressures

	Outdoor Coil Entering Air Temperature											
	65°F		75°F		85°F		95°F		105°F		115°F	
	Suct (psig)	Disc (Psig)	Suct (psig)	Disc (Psig)	Suct (psig)	Disc (Psig)	Suct (psig)	Disc (Psig)	Suct (psig)	Disc (Psig)	Suct (psig)	Disc (Psig)
Circuit 1	87	227	90	264	93	306	97	352	100	404	104	459
	94	229	97	266	100	308	104	355	107	406	111	462
	110	235	113	272	117	314	120	360	124	412	128	467
	131	244	134	280	137	322	141	368	145	419	149	475
Circuit 2	97	220	98	256	100	297	102	345	104	398	107	458
	103	221	105	256	107	298	109	345	112	398	114	457
	119	227	121	261	123	302	126	348	129	400	131	458
	138	237	141	271	143	310	146	355	149	406	152	463
Circuit 3	105	238	107	276	110	319	113	366	116	418	119	475
	113	241	115	279	118	321	120	368	123	420	127	477
	130	249	133	286	135	327	138	374	141	425	145	481
	151	259	153	295	156	336	159	382	162	432	166	488
Circuit 4	110	237	111	275	113	319	115	369	117	425	120	488
	117	240	119	277	121	320	123	370	125	425	128	487
	134	247	136	283	138	325	140	373	143	427	146	487
	154	257	156	292	158	332	161	379	163	432	167	491

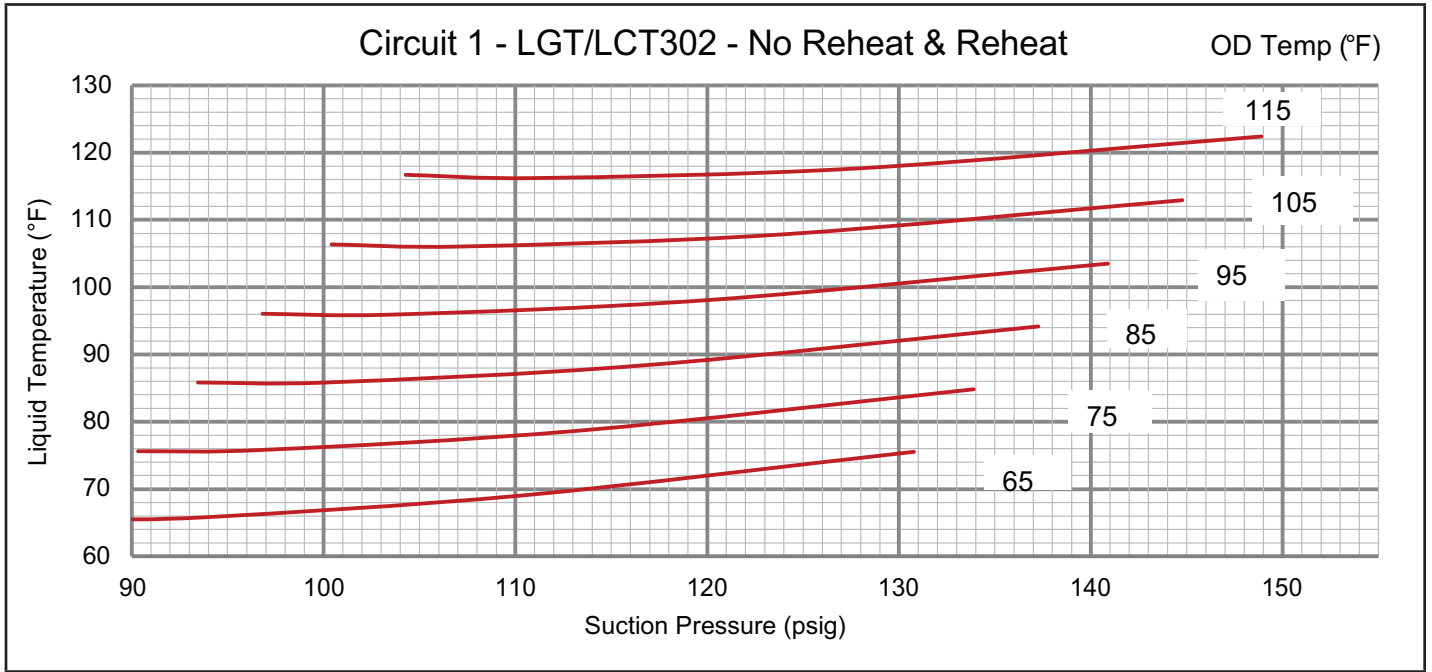

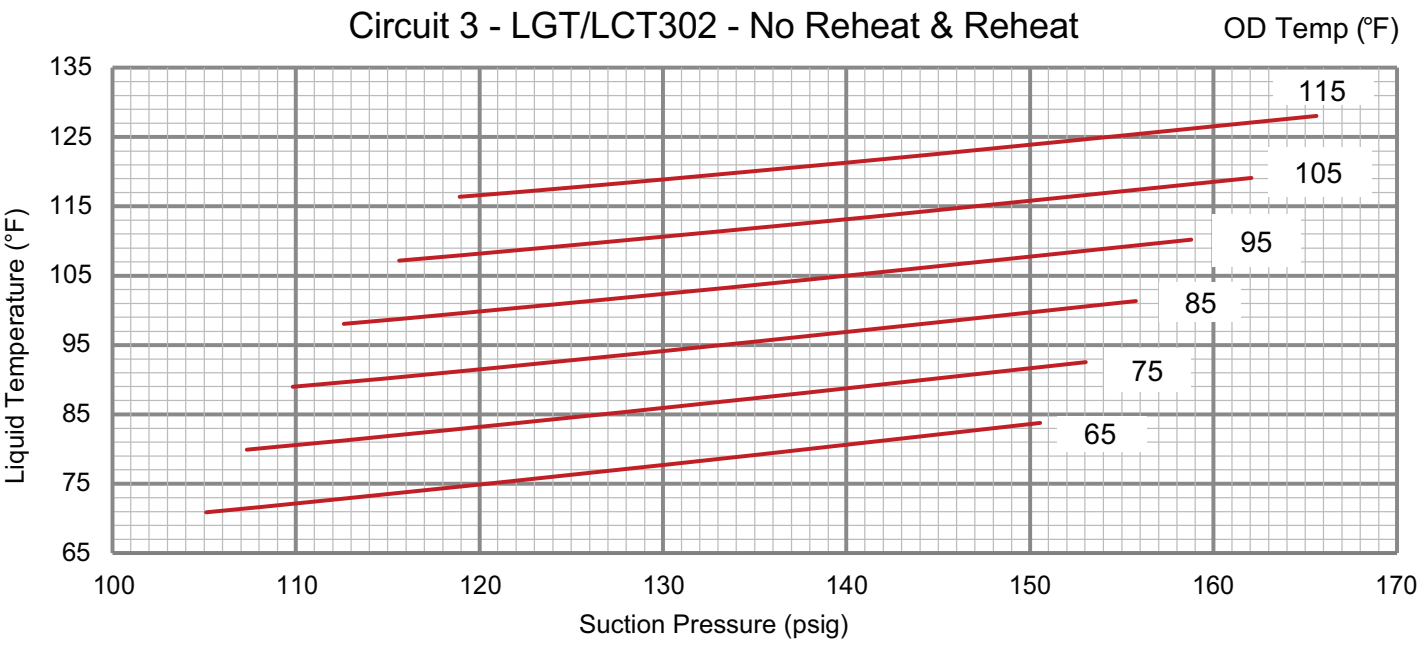
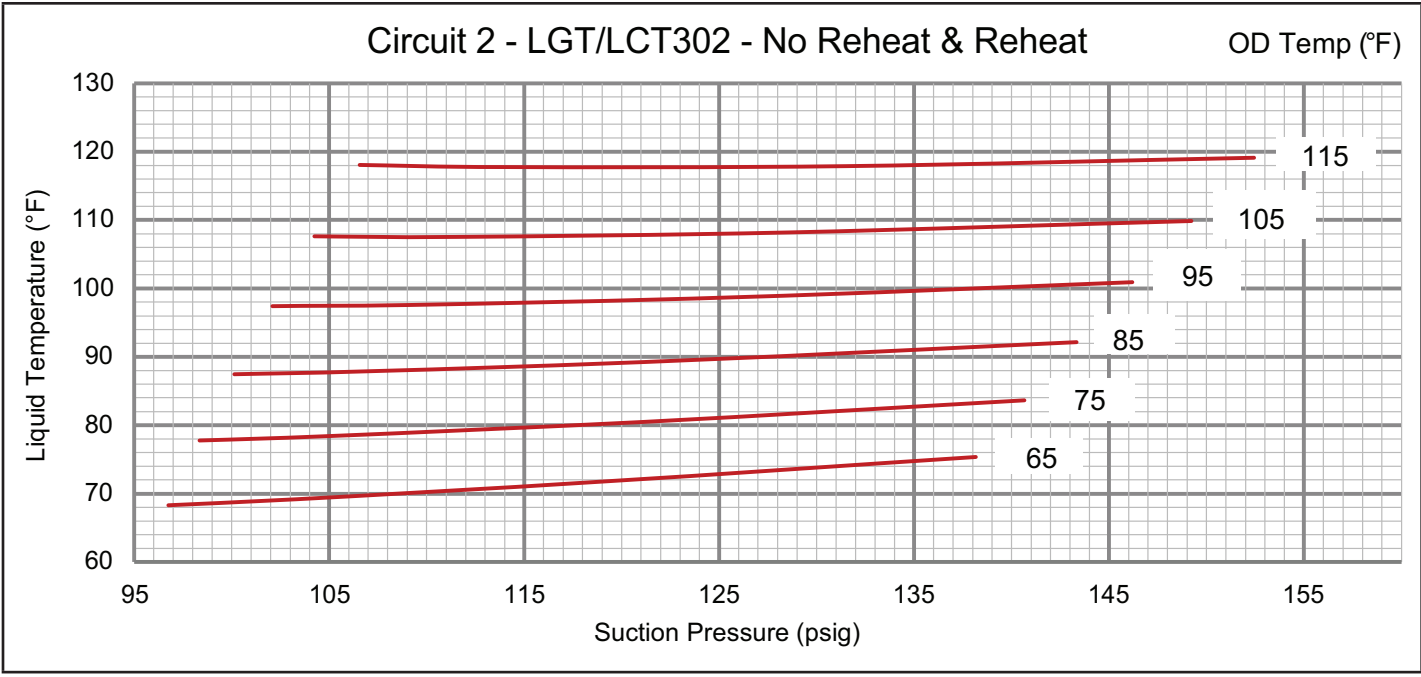

Circuit 4 - LGT/LCT302 - No Reheat & Reheat

OD Temp (°F)

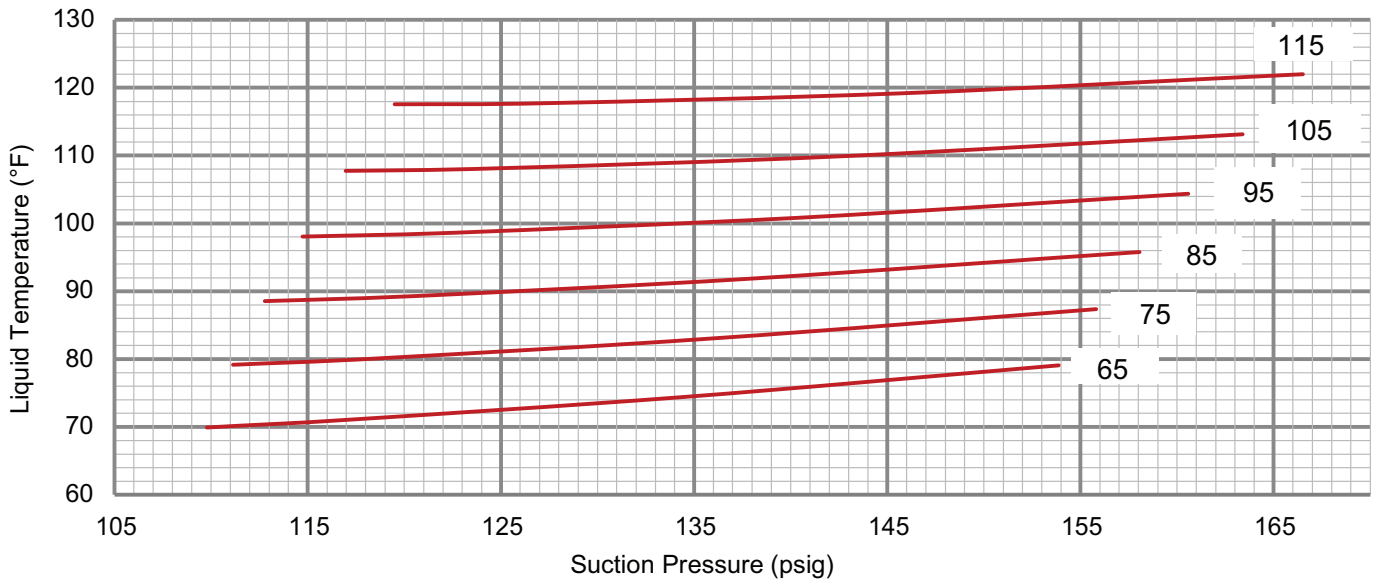
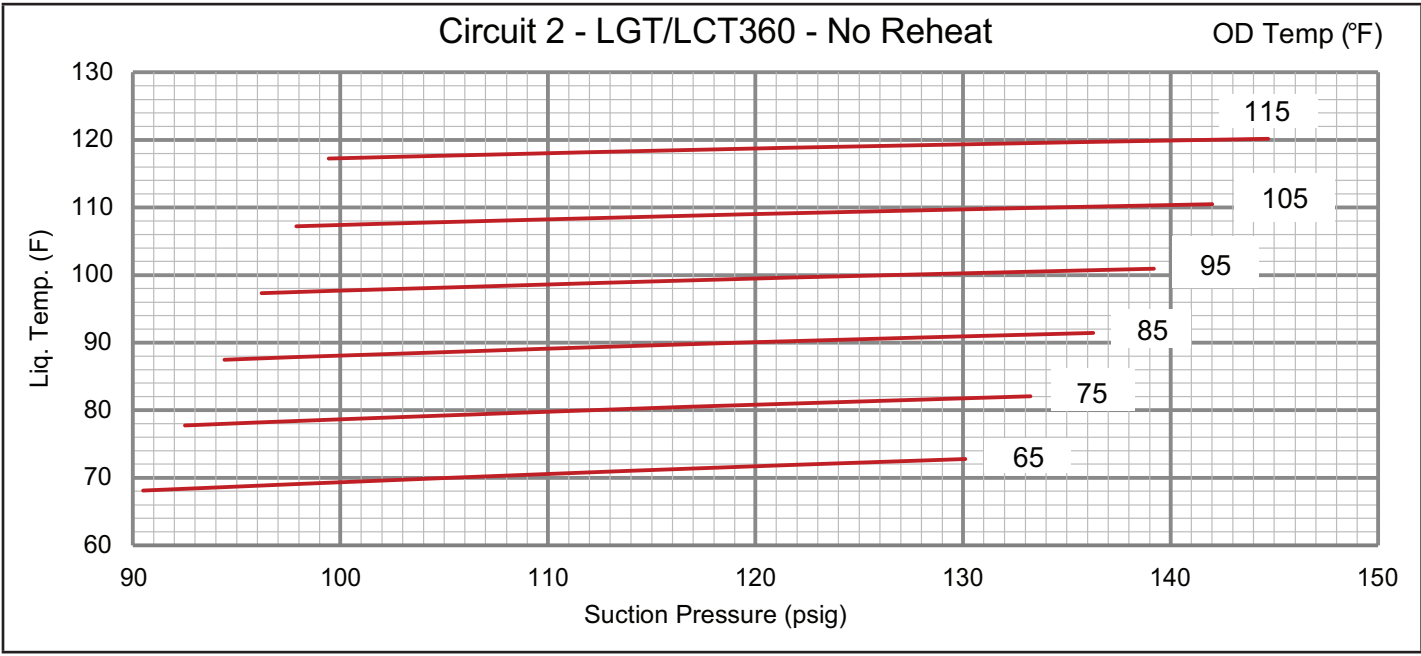
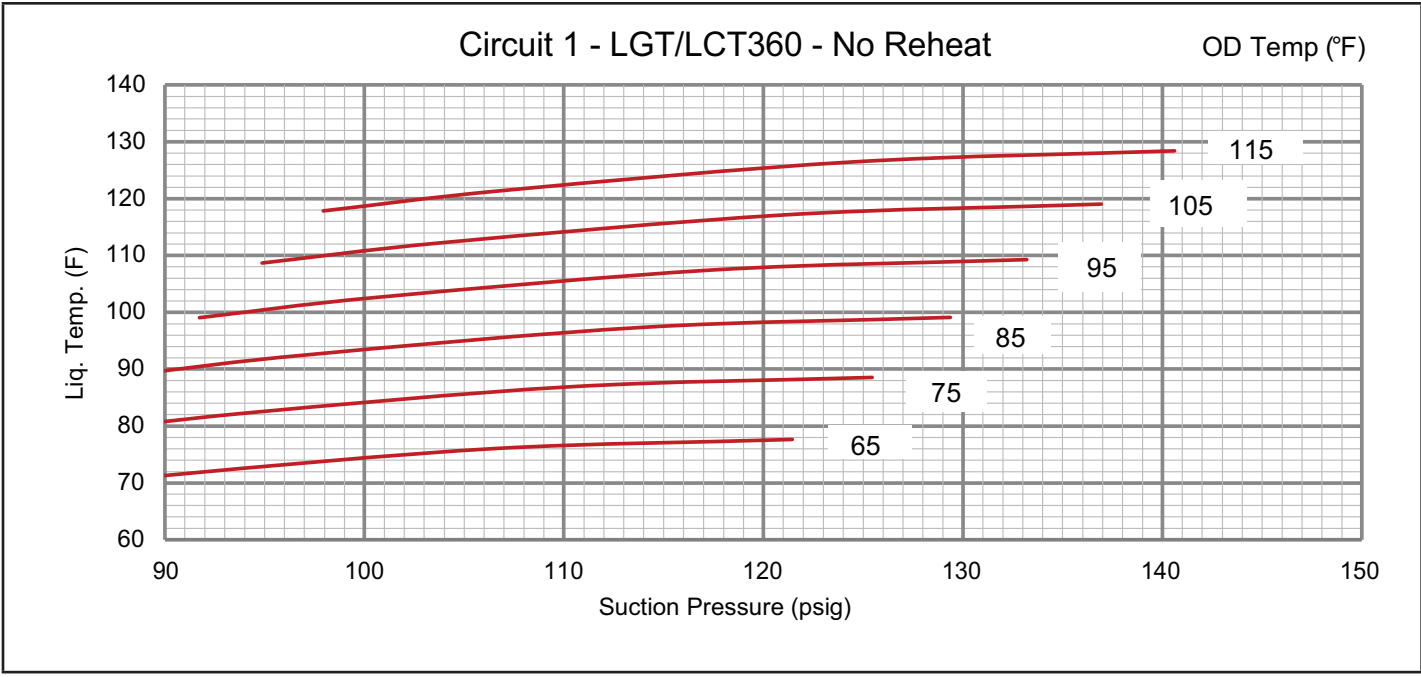

TABLE 8
LG/LCT360H No Reheat Normal Operating Pressures

	Outdoor Coil Entering Air Temperature											
	65°F		75°F		85°F		95°F		105°F		115°F	
	Suct (psig)	Disc (Psig)	Suct (psig)	Disc (Psig)	Suct (psig)	Disc (Psig)	Suct (psig)	Disc (Psig)	Suct (psig)	Disc (Psig)	Suct (psig)	Disc (Psig)
Circuit 1	82	232	85	269	89	309	92	355	95	404	98	457
	90	237	94	274	97	315	101	360	104	410	107	463
	107	247	110	284	114	325	118	370	121	420	125	473
	121	254	125	291	129	333	133	378	137	428	141	481
Circuit 2	91	228	93	265	94	307	96	354	98	406	99	463
	98	232	100	269	103	311	105	358	106	410	108	467
	114	240	117	276	119	318	122	364	124	415	126	472
	130	247	133	282	136	323	139	369	142	420	145	476
Circuit 3	99	254	101	293	103	337	105	386	107	439	109	497
	108	258	111	297	113	341	115	389	117	442	119	500
	126	268	129	306	131	350	134	398	136	450	138	508
	144	280	147	318	150	361	152	409	155	461	157	518
Circuit 4	105	245	106	283	107	325	109	372	110	425	111	482
	113	248	114	285	116	327	118	374	119	426	121	483
	128	256	131	293	134	334	136	381	138	432	141	489
	144	269	148	305	151	346	154	392	157	443	160	499



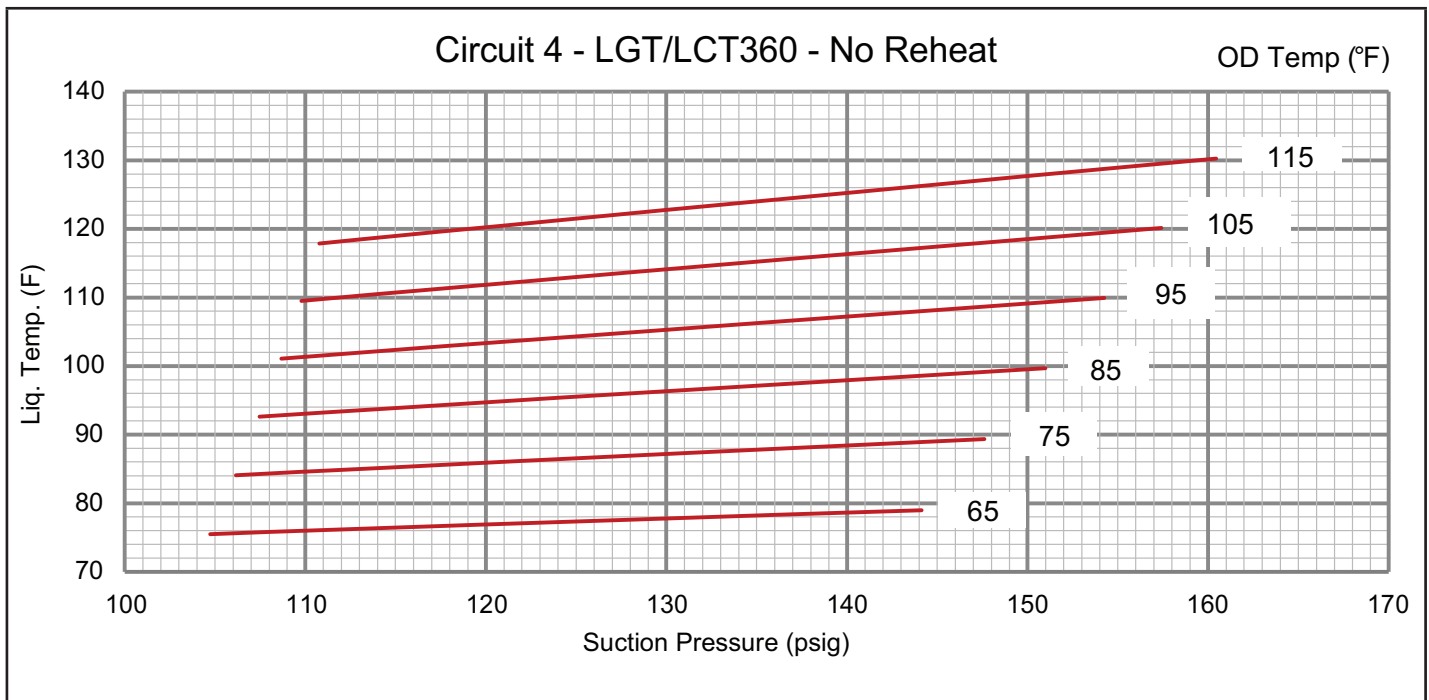
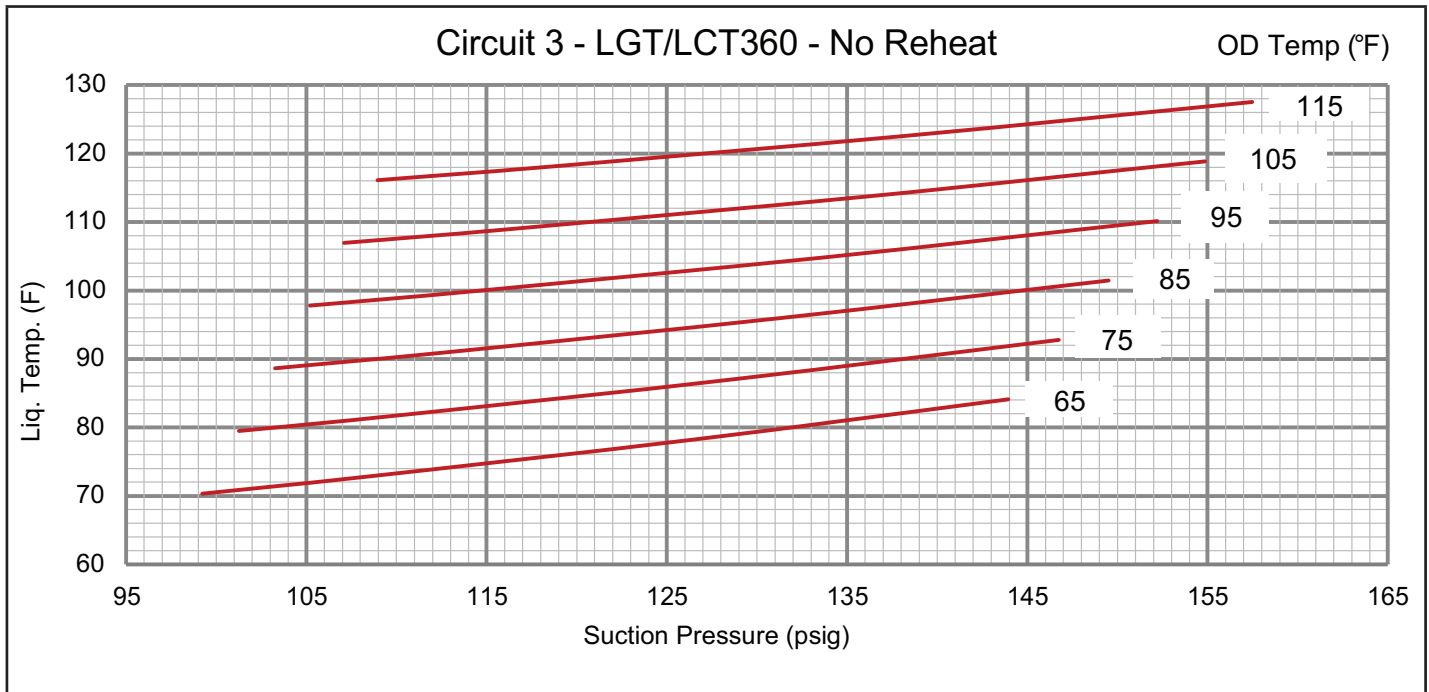
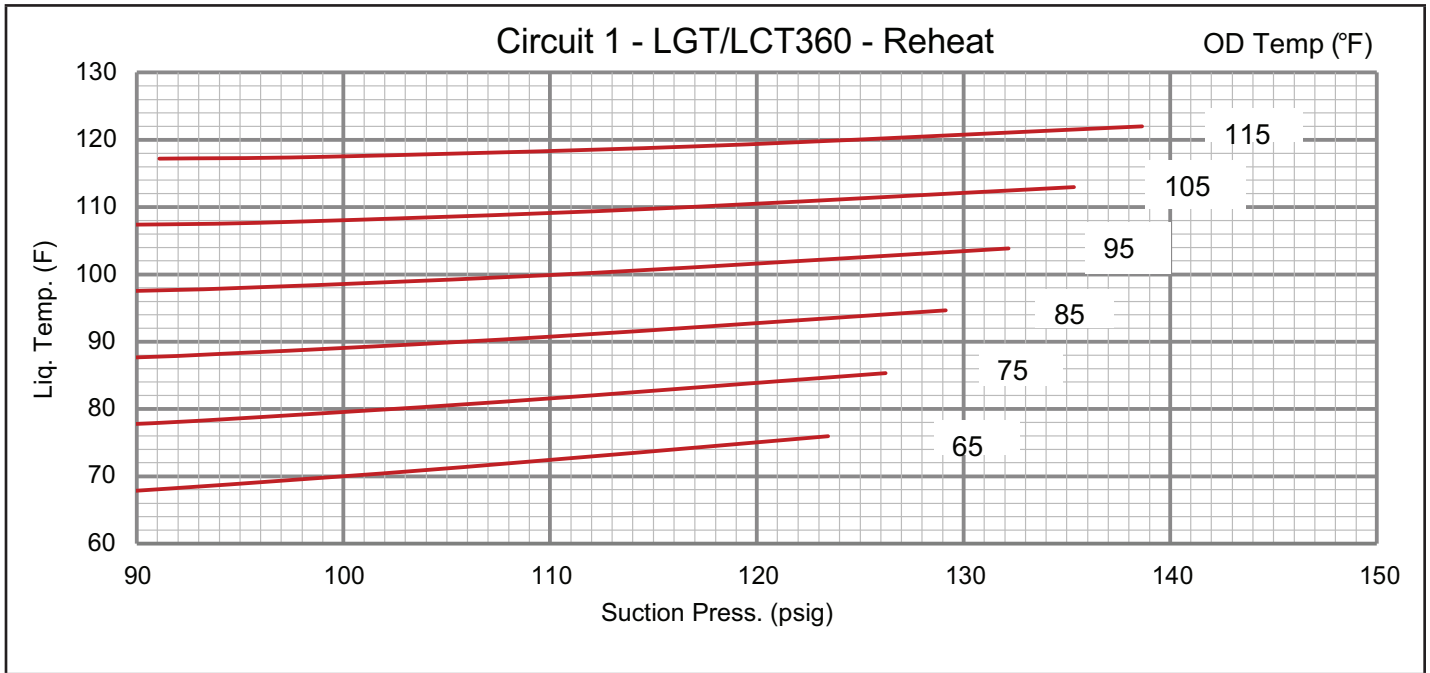
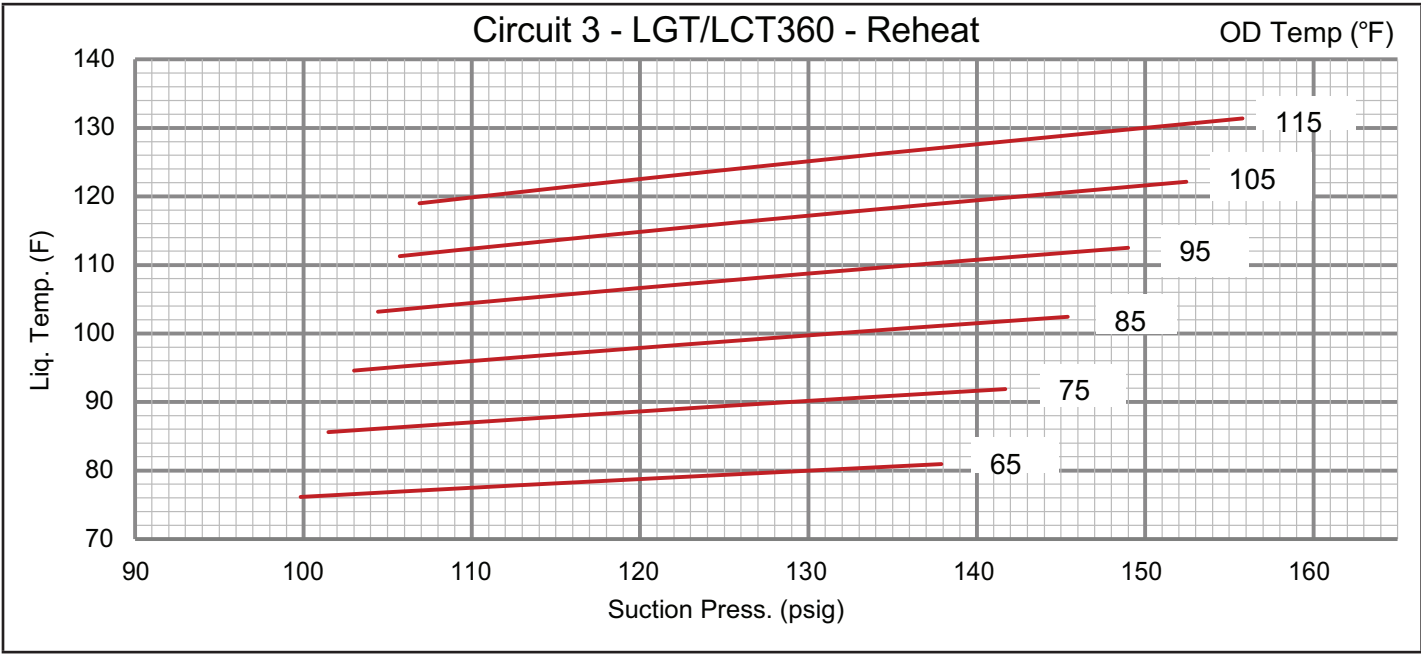
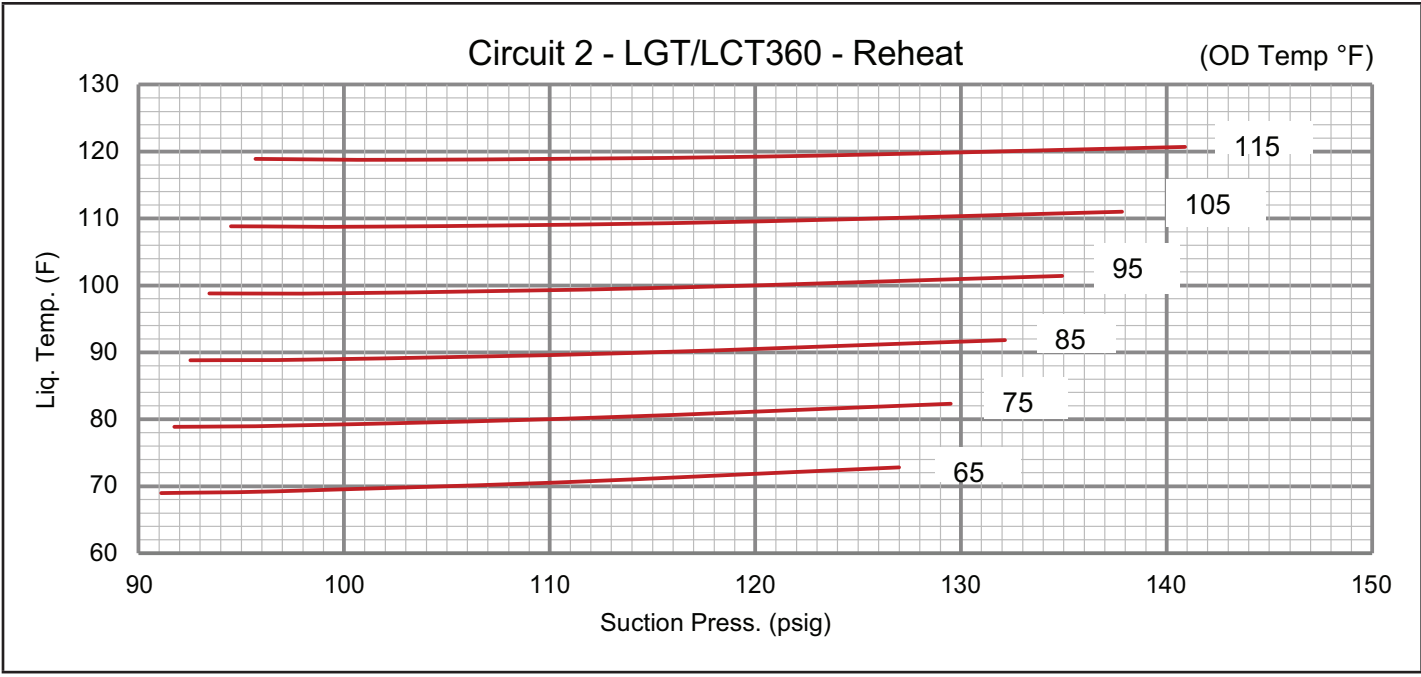

TABLE 9
LGT/LCT360H Reheat Normal Operating Pressures

	Outdoor Coil Entering Air Temperature											
	65°F		75°F		85°F		95°F		105°F		115°F	
	Suct (psig)	Disc (Psig)	Suct (psig)	Disc (Psig)	Suct (psig)	Disc (Psig)	Suct (psig)	Disc (Psig)	Suct (psig)	Disc (Psig)	Suct (psig)	Disc (Psig)
Circuit 1	86	254	87	289	88	330	89	376	90	427	91	484
	92	257	93	292	94	332	96	378	97	429	99	486
	106	268	108	302	110	341	112	386	115	437	117	493
	123	284	126	318	129	356	132	401	135	451	139	507
Circuit 2	91	248	92	281	93	319	93	363	95	412	96	467
	97	251	98	284	99	322	100	365	102	414	103	469
	110	261	112	293	114	331	116	374	118	423	120	477
	127	276	130	307	132	345	135	387	138	436	141	490
Circuit 3	100	244	101	282	103	324	104	370	106	420	107	475
	106	248	108	286	110	328	112	374	114	424	116	479
	121	258	124	296	127	338	130	384	132	434	135	488
	138	269	142	307	145	349	149	395	152	445	156	499
Circuit 4	104	237	104	274	105	316	106	362	107	413	108	467
	110	240	112	277	113	319	114	365	116	415	117	469
	126	248	128	285	130	326	133	371	135	421	137	475
	143	258	146	294	149	335	153	380	156	429	160	483





Circuit 4 - LGT/LCT360 - Reheat

OD Temp (°F)

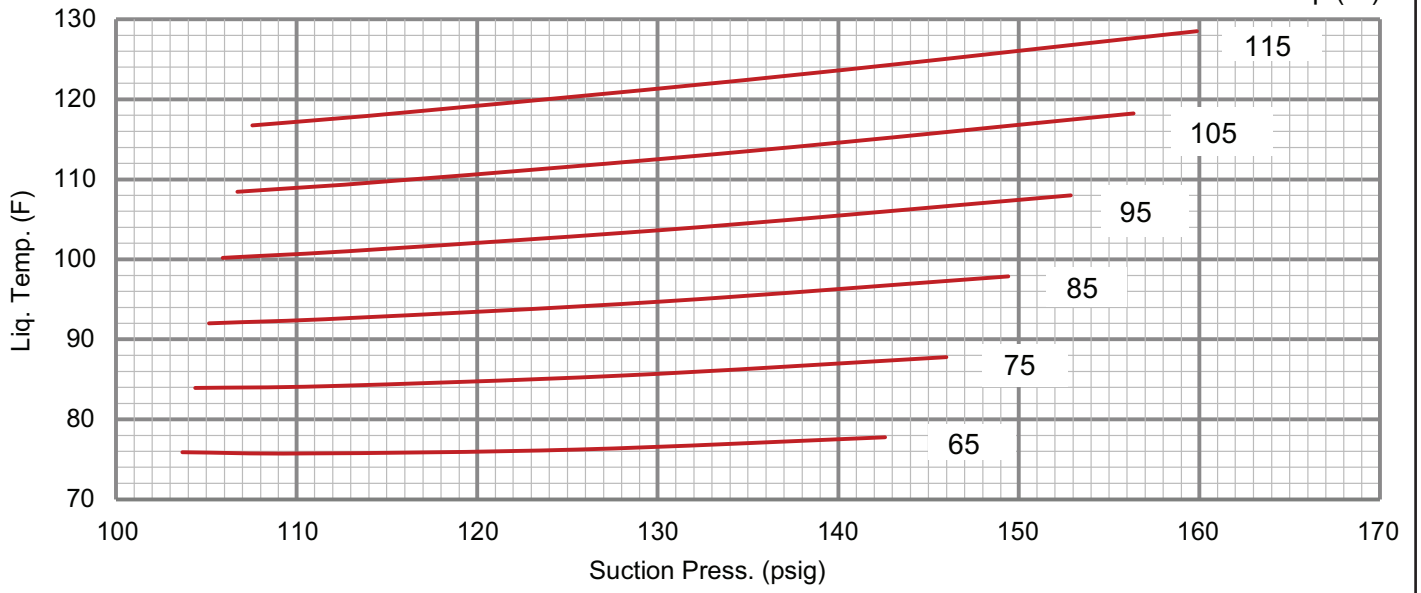

D-Compressor Controls

See unit wiring diagram to determine which controls are used on each unit.

- 1 - High Pressure Switch (S4, S7, S28, S96) - The compressor circuit is protected by a high pressure switch which opens at 610 psig \pm 15 psig (4206 kPa \pm 103 kPa) and automatically resets at 475 psig \pm 15 psig (3275 kPa \pm 103 kPa).
- 2 - Low Pressure Switch (S87, S88, S97, S98) - The compressor circuit is protected by a loss of charge switch. Switch opens at 40 psig \pm 5 psig (276 kPa \pm 34 kPa) and automatically resets at 90 psig \pm 5 psig (621 kPa \pm 34 kPa).
- 3 - Crankcase Heater (HR1, HR2, HR5, HR11) - Units have compressors which contain a belly band compressor oil heater which must be on 24 hours before running compressors. Energize by setting thermostat so that there is no cooling demand, to prevent compressor from cycling, and apply power to unit.
- 4 - Thermal Protector (S5) - Each fixed-speed compressor is protected by an internal thermal protector switch.

Condenser Fan Operation

Condenser fans 1, 2, and 3 are energized when compressor 1 or 2 are energized. As cooling demand increases, all six condenser fans are energized.

Condenser fans 1, 2, 5, and 6 are de-energized when outdoor temperature drops below 62°F (17°C).

Condenser fans 3 and 4 cycle to maintain target liquid temperatures when outdoor temperature drops below 62°F (17°C).

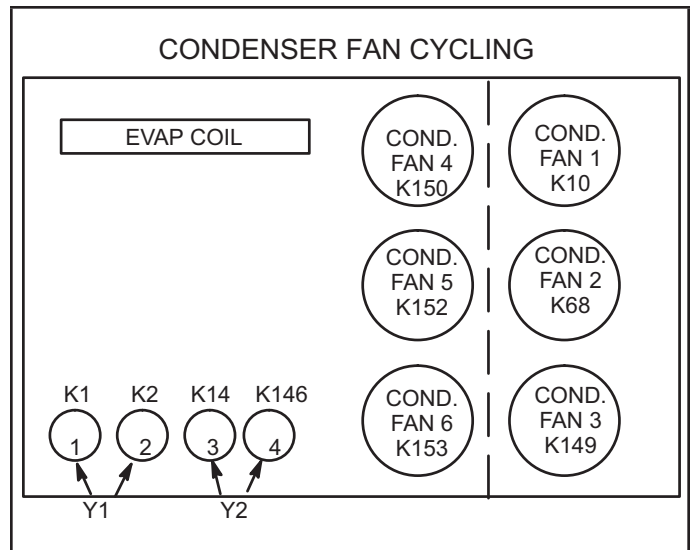

FIGURE 30

Diagnostic Sensors

Units are equipped with factory-installed thermistors located in different points on the refrigerant circuit.

The thermistors provide the Unit Controller with constant temperature readings of two specific locations on the refrigeration circuit. These temperatures are used as feedback in certain modes of unit operation. In addition, the Unit Controller uses these temperatures to initiate alarms such as loss of condenser or evaporator airflow and loss of charge.

Each thermistor must be specifically placed for proper unit operation and to initiate valid alarms. See TABLE 10 for proper locations.

TABLE 10

THERMISTOR LOCATION		
Unit	Sensor	Figure
Indoor Coil	RT46, 47, 50, 51	FIGURE 31
Outdoor Coil	RT48, 49, 52, 53	FIGURE 32

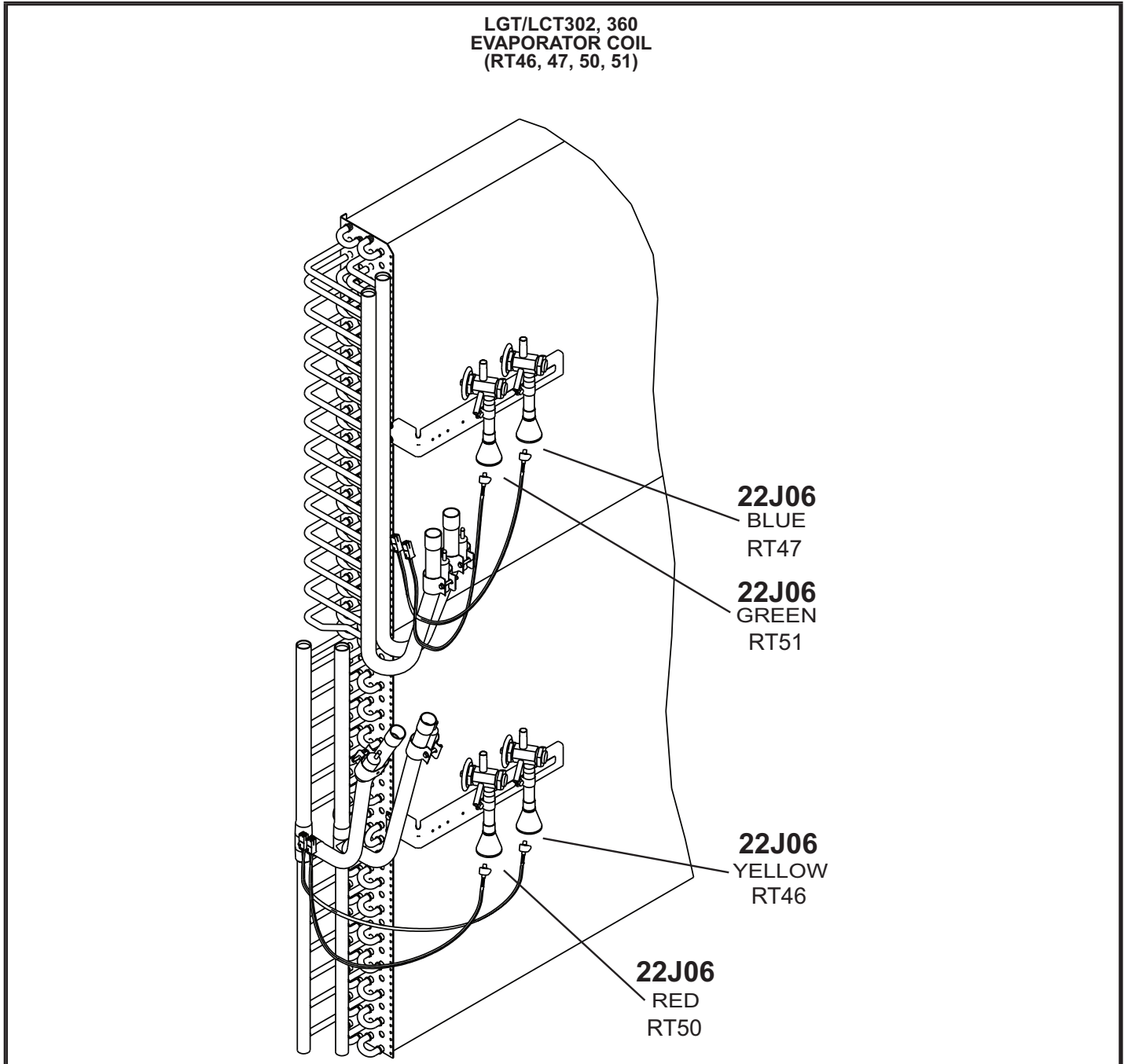

FIGURE 31

LGT/LCT302, 360
 CONDENSER COIL
 RT48, 49, 52, 53

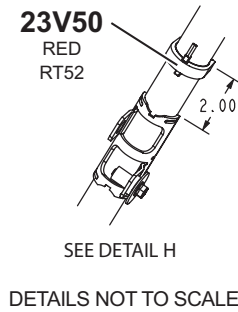
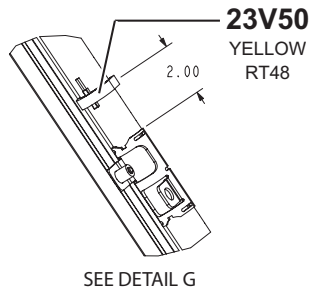
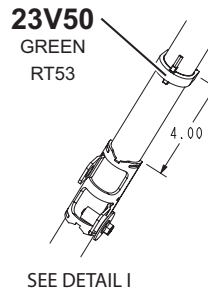
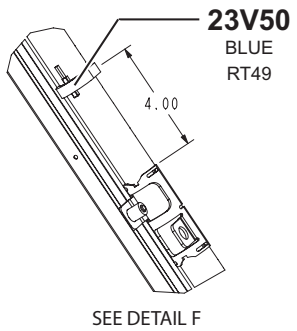
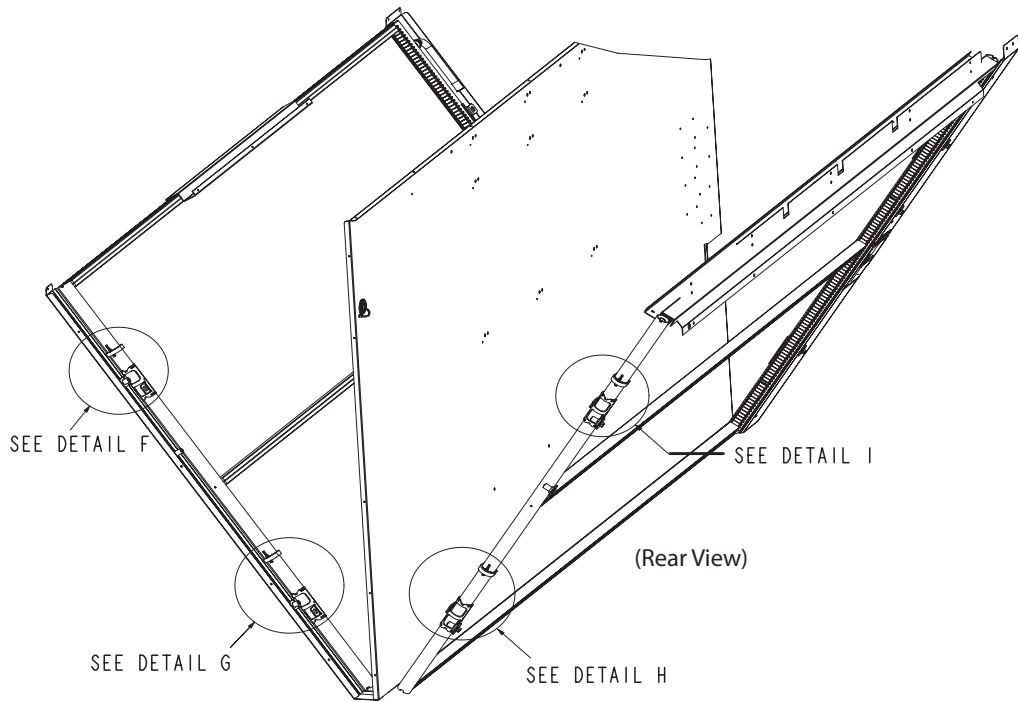

FIGURE 32

RDS Sensors

Units are equipped with factory-installed RDS Sensors located on different points on the unit. The RDS sensors provide the Unit Controller with continuous readings for leaked refrigerant concentration levels and sensor health status (Good or Fault). These readings are used to modify unit operation to disperse the leaked refrigerant and to remove possible ignition sources. In addition, the Unit Controller uses these readings to initiate alarms to alert the operator of a refrigerant leak or faulty sensor(s).

Each sensor must be specifically placed for proper unit operation and to initiate valid alarms. To identify sensor locations see TABLE 11.

TABLE 11
RDS Sensor Figures

Model	Qty.	Type	Figure
LGT/LCT302-360	2 sensors	INDOOR SENSOR	FIGURE 33
		COMPRESSOR SENSOR	FIGURE 34

LGT/LCT302-360
INDOOR COMPARTMENT RDS SENSOR

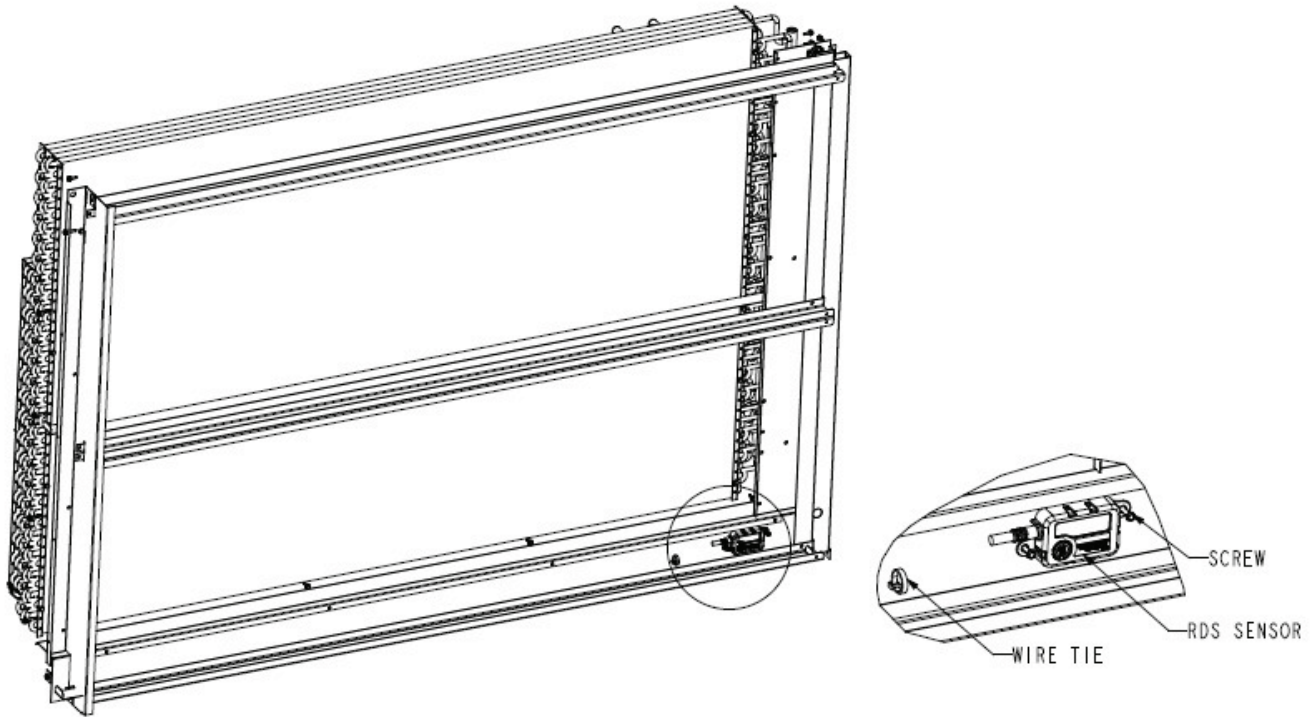

FIGURE 33

LGT/LCT 302-360
COMPRESSOR RDS SENSOR

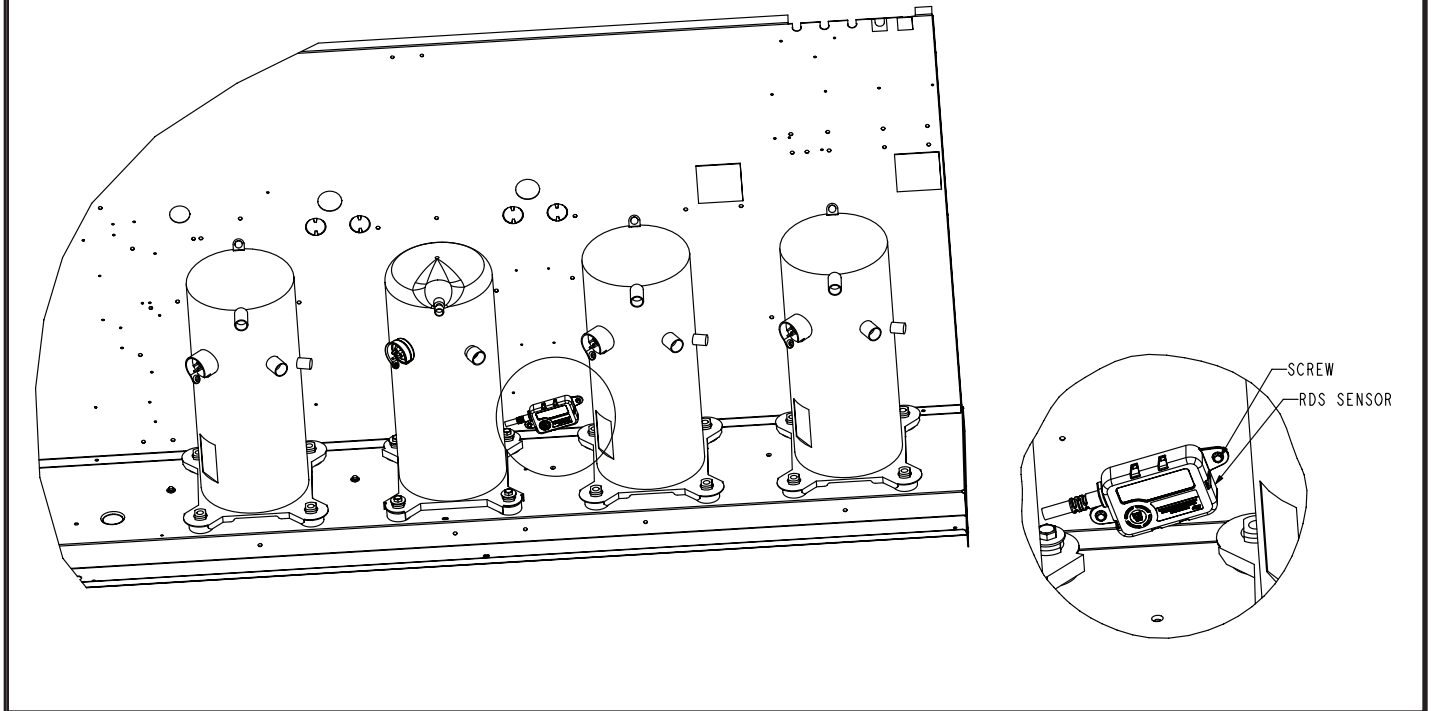

FIGURE 34

Gas Heat Start-Up (Gas Units)

FOR YOUR SAFETY, READ BEFORE LIGHTING

BEFORE LIGHTING smell all around the appliance area for gas. Be sure to smell next to the floor because some gas is heavier than air and will settle on the floor.

Use only your hand to push in or turn the gas control knob. Never use tools. If the knob will not push in or turn by hand, do not try to repair it, call a qualified service technician. Force or attempted repair may result in a fire or explosion.

This unit is equipped with an automatic spark ignition system. There is no pilot. In case of a safety shutdown, move thermostat switch to **OFF** and return the thermostat switch to **HEAT** to reset ignition control.

⚠ WARNING



Danger of explosion. Can cause injury or death. Do not attempt to light manually. Unit has a direct spark ignition system.

⚠ WARNING



Electric shock hazard. Can cause injury or death. Do not use this unit if any part has been under water. Immediately call a qualified service technician to inspect the unit and to replace any part of the control system and any gas control which has been under water.

⚠ WARNING



Danger of explosion. Can cause injury or product or property damage. If over heating occurs or if gas supply fails to shut off, shut off the manual gas valve to the appliance before shutting off electrical supply.

⚠ WARNING

SMOKE POTENTIAL

The heat exchanger in this unit could be a source of smoke on initial firing. Take precautions with respect to building occupants and property. Vent initial supply air outside when possible.

⚠ WARNING



Electric shock hazard. Can cause injury or death. Before attempting to perform any service or maintenance, turn the electrical power to unit **OFF** at disconnect switch(es). Unit may have multiple power supplies.

A-Placing Unit in Operation

⚠ WARNING



Danger of explosion and fire. Can cause injury or product or property damage. You must follow these instructions exactly.

Gas Valve Operation for White Rodgers 36H54 (FIGURE 35) Series Gas Valve

- 1 - Set thermostat to lowest setting.
- 2 - Turn off all electrical power to appliance.
- 3 - This appliance is equipped with an ignition device which automatically lights the burner. Do **not** try to light the burner by hand.
- 4 - Open or remove the heat section access panel.

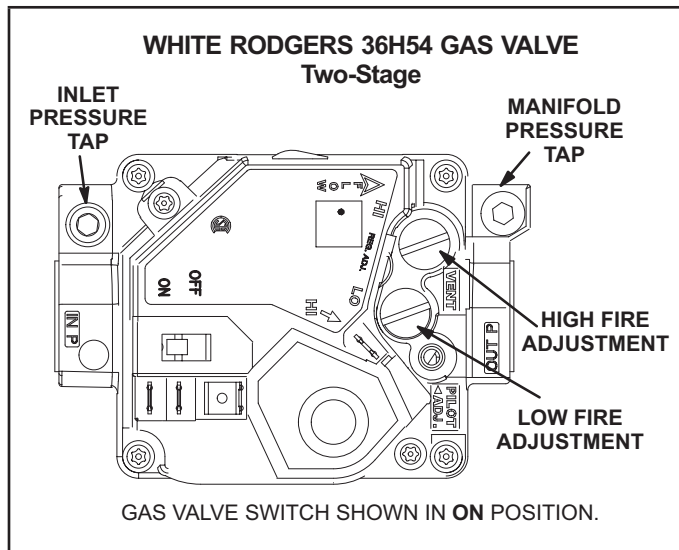

FIGURE 35

- 5 - Turn the knob on the gas valve clockwise to **OFF**. Do not force.
- 6 - Wait five minute to clear out any gas. If you then smell gas, **STOP!** Immediately call your gas supplier from a neighbors phone. Follow the gas supplier's instructions. If you do not smell gas, go to the next step.
- 7 - Turn on the knob on the gas valve counterclockwise to **ON**. Do not force.
- 8 - Close or replace the heat section access panel.
- 9 - Turn on all electrical power to unit.

- 10 - Set thermostat to desired setting.
- 11 - The ignition sequence will start.
- 12 - If the appliance does not light the first time (gas line not fully purged), it will attempt up to two more ignitions before locking out.
- 13 - If lockout occurs, repeat steps 1 through 10.
- 14 - If the appliance will not operate, follow the instructions "Turning Off Gas to Appliance" and call your service technician or gas supplier.

Turning Off Gas to Unit

- 1 - If using an electromechanical thermostat, set to the lowest setting.
- 2 - Before performing any service, turn off all electrical power to the unit.
- 3 - Open or remove the heat section access panel.
- 4 - Turn the knob on the gas valve clockwise to **OFF**. Do not force.
- 5 - Close or replace the heat section access panel.

Heating Operation and Adjustments

(Gas Units)

A-Heating Sequence of Operation

- 1 - On a heating demand the combustion air inducer starts immediately.
- 2 - Combustion air pressure switch proves inducer operation. After a 30 second pre-purge, power is allowed to ignition control. Switch is factory set and requires no adjustment.
- 3 - Spark ignitor energizes and gas valve solenoid opens.
- 4 - Spark ignites gas, ignition sensor proves the flame and combustion continues.
- 5 - If flame is not detected after first ignition trial, ignition control will repeat steps 3 and 4 two more times before locking out the gas valve.
- 6 - For troubleshooting purposes, an ignition attempt after lock out may be re-established manually. Move thermostat to **OFF** and return thermostat switch to **HEAT** position.

B-Limit Controls

Limit controls are factory-set and are not adjustable. Two limits are located on the drip shield in the blower compartment. See FIGURE 36.

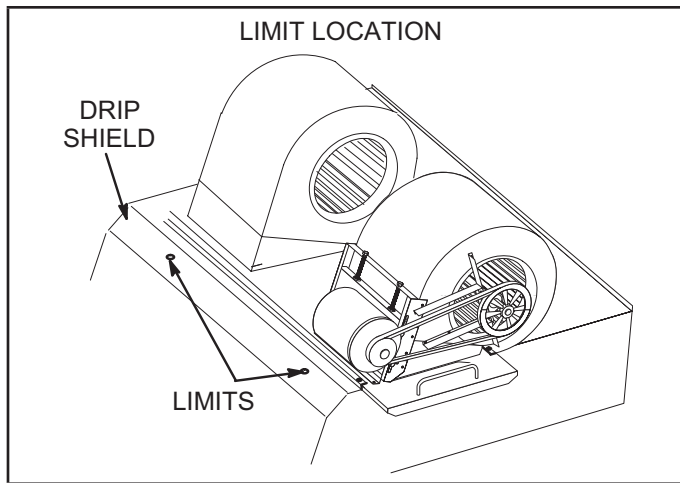

FIGURE 36

C-Heating Adjustment

Main burners are factory-set and do not require adjustment. Gas manifold pressures should match pressures shown in TABLE 12.

TABLE 12

Natural Gas		Propane (LP) Gas	
1st Stage ± 0.2	2nd Stage ± 0.3	1st Stage ± 0.2	2nd Stage ± 0.3
1.6	3.7	5.5	10.5

Electric Heat Start-Up (LCH Units)

Factory or Field-Installed Option

Electric heat will stage on and cycle with thermostat demand. Number of stages of electric heat will vary depending on electric heat assembly. See electric heat wiring diagram on unit for sequence of operation.

Variable Air Volume Start-Up

Units may contain an optional supply air blower equipped with a variable frequency drive A96 (VFD) which varies supply air CFM.

The supply air VFD (A96) is located near the compressors. See FIGURE 37.

A-Start-Up

- 1 - A pressure transducer (A30) is shipped in a box in the blower compartment. Install the transducer according to manufacturer's instructions.

NOTE - Make sure the transducer is installed in the main duct at least 2/3 of the distance away from the unit.

- 2 - Two twisted pairs of shielded cable must be used to connect the pressure transducer. See FIGURE 38.
- 3 - Open all zone dampers and/or boxes.
- 4 - Locate the A55 Unit Controller. Refer to FIGURE 37.

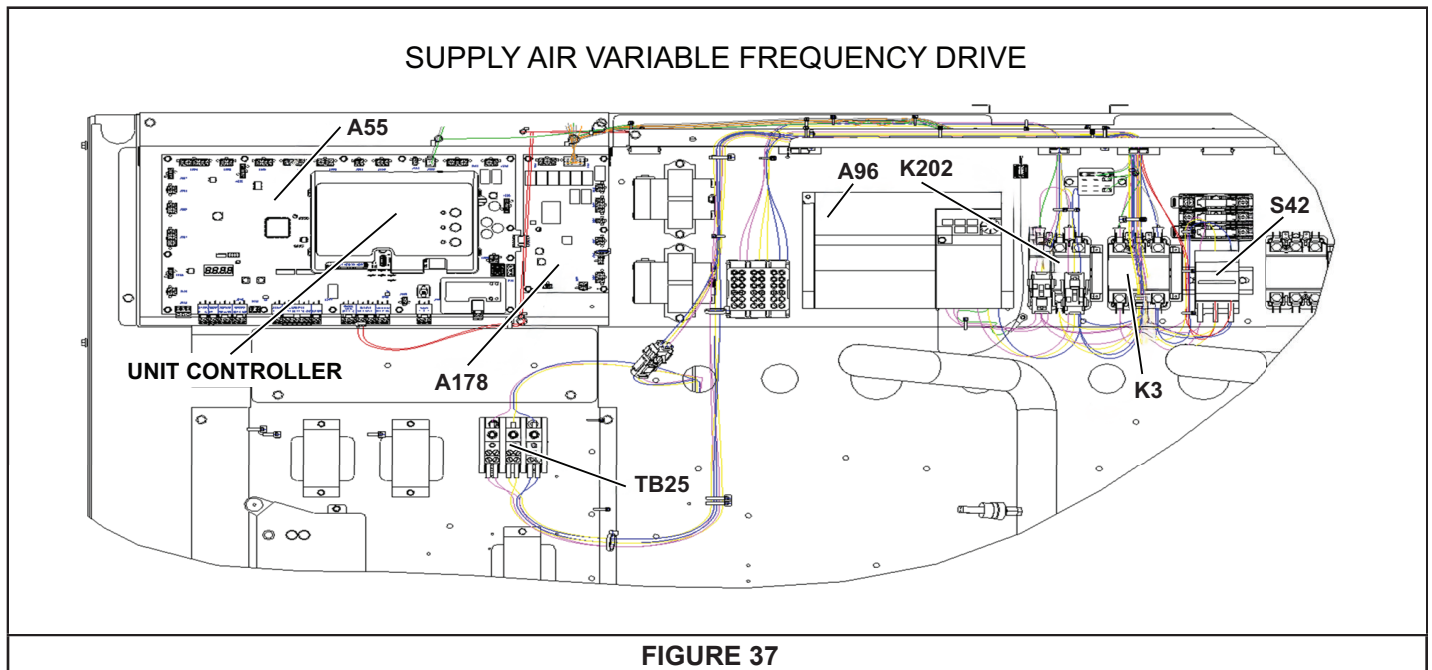

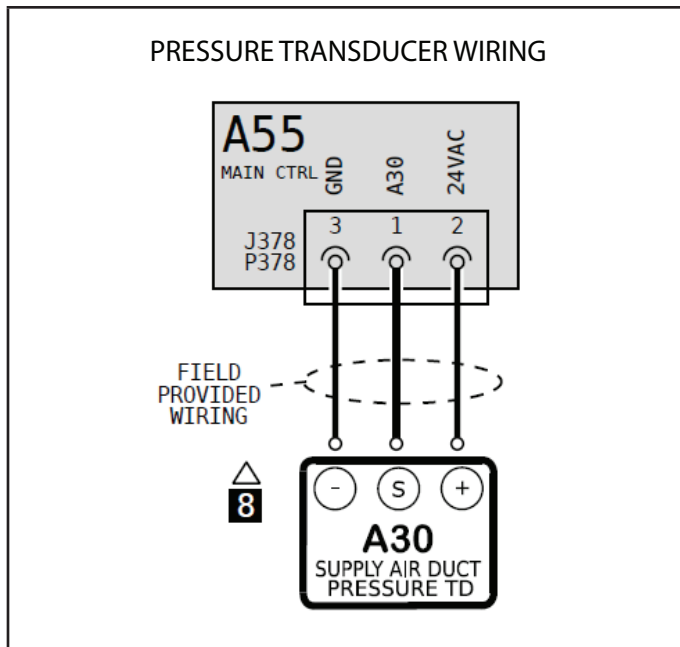

FIGURE 38

- 5 - Use the Unit Controller to calibrate the blower CFM. Select the **RTU MENU** → **TEST & BALANCE** → **BLOWER** menu to start the blower. The Unit Controller will display the percent of blower speed. Adjust the blower speed percentage to meet design airflow specifications. Allow blower speed to stabilize.
- 6 - Press **SAVE** to display the current static pressure. If the static pressure meets the design specification, press **SAVE** again to set the setpoint. If the static pressure does not meet the design specification, adjust the pressure and press **SAVE** to set the setpoint.
- 7 - Record new setpoints in TABLE 13.

NOTE - The Unit Controller will lock-out the unit for 5 minutes if static pressure exceeds 2.0 inc w.c. for 20 seconds, The Unit Controller will permanently shut down the unit after three occurrences. See Unit Controller parameters 110, 42, and 43 to adjust default values.

- 8 - If the desired CFM cannot be met with the current pulley setup, refer to the *Blower Operation and Adjustments* section to adjust CFM.

B-Unit Operation

Use the Unit Controller to check unit mechanical operation. See the *Service - Test* section of the Unit Controller manual.

**TABLE 13
RECORD ADJUSTED SETPOINTS**

Parameter	Setpoint Description	Setpoint "w.c."	Display Setting
386	Smoke		
387	Ventilation		
388	Heating		
389	Cooling		

D-Set Damper Minimum Position

To maintain required minimum ventilation air volumes when the unit is in the occupied mode, two minimum damper positions must be set.

The Unit Controller will open the damper to "Min OCP Blwr High" when blower CFM is at or ABOVE the "midpoint" CFM.

The Unit Controller will open the dampers to "Min OCP Blwr Low" when blower CFM is BELOW a "midpoint" CFM.

The Unit Controller will calculate the "midpoint" CFM.

**TABLE 14
Blower CFM Design Specifications**

Unit	T'Stat or Zone Control Stages	Blower Speed	Design Specified CFM
302	2	Htg.	
		Clg. High	
		Clg. Low	
		Ventilation	
360	2	Htg.	
		Clg. High	
		Clg. Low	
		Ventilation	

*Available blower speed vary by unit and thermostat stages.

Set Minimum Position 1

Use the following mobile service app menu to set "Min OCP Blwr High" for the blower CFM above the "midpoint" CFM. When navigating into this menu, the Unit Controller will run damper calibration and allow damper position adjustment.

RTU MENU > SETTINGS > RTU OPTIONS > DAMPER

Tap "Next" to skip tabs and complete damper position calibration until "Damper Calibration Blower Speed High" tab appears.

Measure the intake air CFM. If the CFM is lower than the design specified CFM for ventilation air, use the Unit Controller to increase the damper percent open. If the CFM is higher than specified, decrease the damper percent open.

NOTE - Intake air CFM can also be determined using the outdoor air temperature, return air temperature and mixed air temperature. Refer to the economizer or outdoor air damper installation instructions.

**TABLE 15
HEATING, VENTILATION, & SMOKE MINIMUM AND MAXIMUM CFM**

Model	Speed	Heat Code	Heating CFM			Vent CFM			Smoke CFM		
			Default	Min.	Max.	Default	Min.	Max.	Default	Min.	Max.
LGT302H5M	Medium	S, M	10500	5925	12000	10500	3750	12000	10500	3750	12000
	High	H		7125							
LCT302H5M	All	N, J, K, L, P, S		10500							
LGT360H5M	Medium	S, M	12000	5925	14400	12000	4500	14400	12000	4500	14400
	High	H		7125							
LCT360H5M	All	N, J, K, L, P, S		10500							

*Use highest value between Heating and Cooling High CFM Max.

**TABLE 16
COOLING MINIMUM AND MAXIMUM CFM**

LGT/ LCT Unit	Cool 1 CFM Cooling Low CFM			Cool 4 CFM Cooling High CFM		
	Default	Min.	Max.	Default	Min.	Max.
302H	6500	4000	12000	9000	7000	12000
360H	7800	4800	14400	10800	8400	14400

*Use Cooling High CFM Max

Set Minimum Position 2

Use the following mobile service app menu in the Unit Controller to set “Min OCP Blwr Low” for the blower CFM below the “midpoint” CFM. When navigating into this menu, the Unit Controller will run damper calibration and allow damper position adjustment.

RTU MENU > SETTINGS > RTU OPTIONS > DAMPER

Tap “Next” to skip tabs and complete damper position calibration until “Damper Calibration Blower Speed High” tab appears.

Measure the intake air CFM. If the CFM is lower than the design specified CFM for ventilation air, use the Unit Controller to increase the damper percent open. If the CFM is higher than specified, decrease the damper percent open.

NOTE - Intake air CFM can also be determined using the outdoor air temperature, return air temperature and mixed air temperature. Refer to the economizer or outdoor air damper installation instructions.

E-Inverter Bypass Option

To configure the unit to by-pass the inverter automatically, use the following Unit Controller menu.

SETUP > INSTALL

Press SAVE until the menu reads:

CONFIGURATION ID 1

Change the 6th character position to A for automatic bypass option.

Press SAVE

CAUTION - Units not equipped with an inverter will have the 6th character set to N, indicating the inverter is not bypassed. The blower motor could be damaged and/or result in product or property damage if the setting is changed to automatic or manual.

Multi-Staged Air Volume Start-Up

A-Design Specifications

Use TABLE 17 to fill in field-provided, design specified blower CFM for appropriate unit.

If only high and low cooling design specifications are provided, set the medium cooling CFM at the high or low cooling design spec or any CFM between.

B-Set Maximum CFM

Use TABLE 15 to determine highest blower CFM for appropriate unit. Adjust the blower pulley to deliver that amount of CFM with only the blower operating. See the Blower Operation and Adjustment section.

C-Set Blower Speeds

- 1 - Use the following menu to enter the blower design specified CFM into the Unit Controller. Make sure blower CFM is within limitations shown in TABLE 18. Refer to the Unit Controller manual provided with unit.

RTU MENU → TEST & BALANCE → BLOWER

- 2 - Enter the following design specifications as shown in TABLE 17.

Blower / Heat CFM

Cooling High CFM¹

Cooling Low CFM¹

Vent CFM

¹The Unit Controller will prompt when more cooling stages are available depending on the number of compressors and the control mode.

- 3 - Adjust the blower RPM to deliver the target CFM based on the measured static pressure using the blower table.
- 4 - Measure the static pressure again and apply the static pressure and RPM to the blower tables to determine adjusted CFM.
- 5 - Repeat adjustments until design CFM is reached.

D-Inverter Bypass Option

The supply air inverter is factory-set to bypass the inverter manually. To bypass the inverter and operate the blower in the constant air volume mode, use the following Unit Controller menu and set to “engaged”:

SETTINGS → RTU OPTIONS → BLOWER → VFD BYPASS

To configure the unit to bypass the inverter automatically, use the following Unit Controller menu.

SETUP → INSTALL

Press SAVE until the menu reads:

CONFIGURATION 1D 1

Change the 6th character position to A for automatic bypass option.

Press SAVE.

CAUTION - Units not equipped with an inverter will have the 6th character set to N, indication the inverter is not bypassed. The blower motor could be damaged and/or result in product or property damage if the setting is changed to automatic or manual.

**TABLE 17
CFM DESIGN SPECIFICATIONS -
300 & 360 UNITS WITH STAGED BLOWER**

No. of Stages / Control Type	Blower Speed ¹	Design Specified CFM
2 Stages / T'stat	Htg.	
	Clg. High	
	Clg. Low	
	Ventilation	
3 Stages / T'stat ²	Htg.	
	Clg. High	
	Clg. Med.	
	Clg. Low	
	Ventilation	
4 Stages / Room Sensor OR Discharge Air Control	Htg.	
	Clg. High	
	Clg. Med. High	
	Clg. Med. Low	
	Clg. Low	
	Ventilation	

¹Available blower speeds vary by unit and thermostat stages.

²Requires a transfer relay (K27) and three-stage thermostat.

**TABLE 18
MINIMUM AND MAXIMUM CFM -
302 & 360 UNITS WITH STAGED BLOWERS**

Unit	Gas Heat Size	Airflow CFM
Gas Heat Minimum CFM		
LGT302	Std., Med.	5950
LGT302	High	7125
LGT360	Std., Med.	5950
LGT360	High	7125
Electric Heat Minimum CFM		
Unit	Heat Size (kW)	Airflow CFM
LCT302, 360	All	10,500
Cooling Minimum CFM		
Unit	Blower Speed	Airflow CFM
LGT/LCT302	Cool 1; Clg. Low	4000
LGT/LCT302	Cool 2; Clg. Med. Low	4000
LGT/LCT302	Cool 3; Clg. Med. High	4000
LGT/LCT302	Cool 4; Clg. High	7000
Cooling Minimum CFM		
Unit	Blower Speed	Airflow CFM
LGT/LCT360	Cool 1; Clg. Low	4800
LGT/LCT360	Cool 2; Clg. Med. Low	4800
LGT/LCT360	Cool 3; Clg. Med. High	4800
LGT/LCT360	Cool 4; Clg. High	8400
Smoke and Ventilation Minimum CFM		
Unit	Not Applicable	Airflow CFM
LGT/LCT302	NA	3750
LGT/LCT360	NA	4500
Heating and Cooling Maximum CFM		
Unit	Blower Speed	Airflow CFM
LGT/LCT302	High	12000
LGT/LCT360	High	14400

Hot Gas Reheat Start-Up and Operation

General

Hot gas reheat units provide a dehumidifying mode of operation. These units contain a reheat coil adjacent to and downstream of the evaporator coil. Reheat coil solenoid valves, L14 and L30, route hot discharge gas from the compressor to the reheat coil. Return air pulled across the evaporator coil is cooled and dehumidified; the reheat coil adds heat to supply air.

See FIGURE 39 for reheat refrigerant routing. See FIGURE 40 for cooling only refrigerant routing.

L14/L30 Reheat Coil Solenoid Valve

When Unit Controller input (Unit Controller J298-5 or J299-8) indicates room conditions require dehumidification, L14/L30 reheat valve is energized (Unit Controller P269-3 or P269-4) and refrigerant is routed to the reheat coil.

Reheat Setpoint

Reheat is factory-set to energize when indoor relative humidity rises above 60% (default). The reheat setpoint can be adjusted by changing Unit Controller Settings - Control menu. A setting of 100% will operate reheat from an energy management system digital output.

Reheat will terminate when the indoor relative humidity falls 3% (57% default) or the digital output de-energizes. The reheat deadband can be adjusted at *Settings - Control* menu.

A91 Humidity Sensor

Relative humidity should correspond to the sensor (A91) output voltage listed in TABLE 19. For example: if indoor air relative humidity is $80\% \pm 3\%$, the humidity sensor output should read 8.00VDC.

Check the sensor output annually for accuracy. Keep the air intake openings on the sensor clean and free of obstructions and debris

TABLE 19

Relative Humidity (%RH $\pm 3\%$)	Sensor Output (VDC)
20	2.00
30	3.00
40	4.00
50	5.00
60	6.00
70	7.00
80	8.00
90	9.00

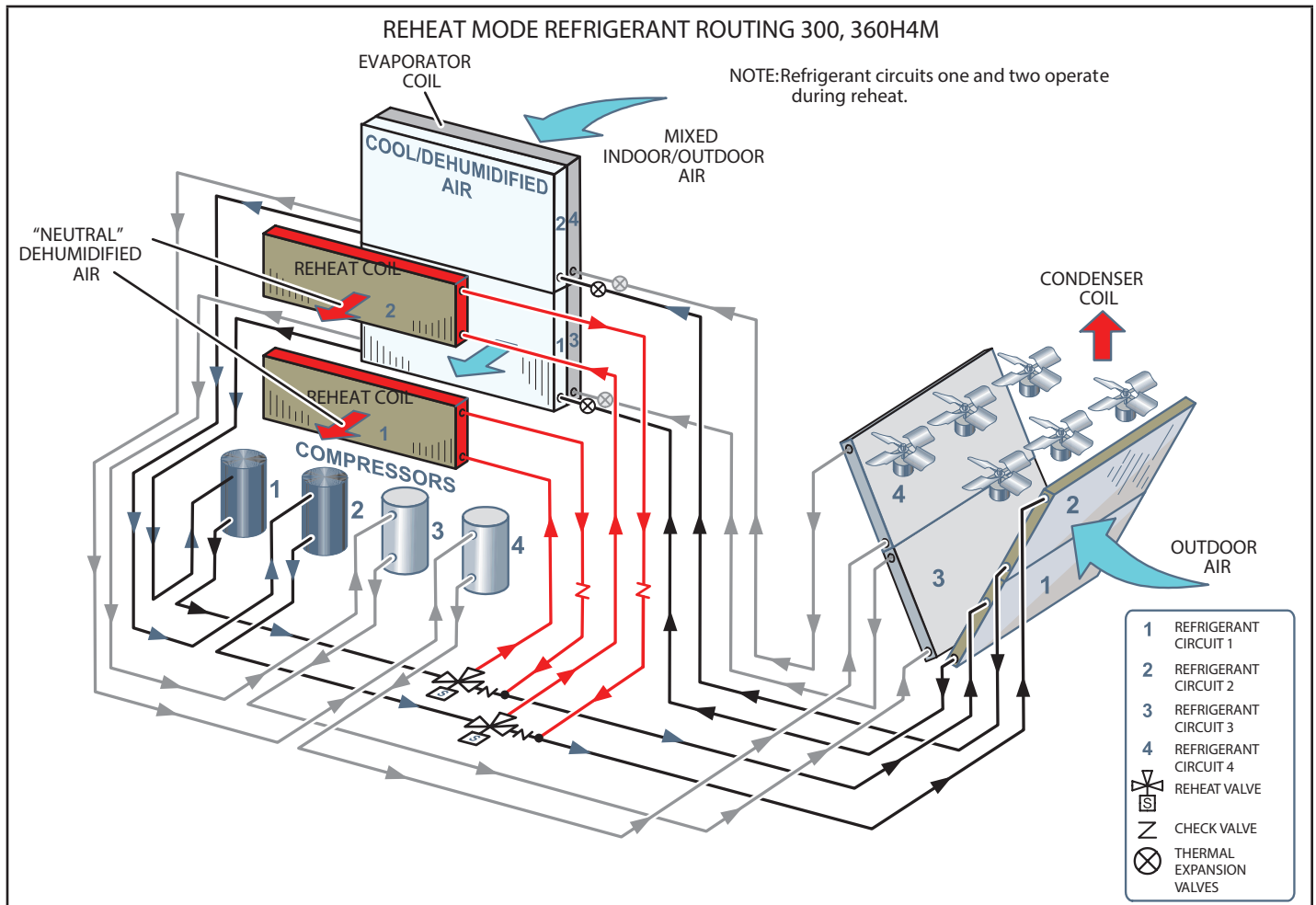
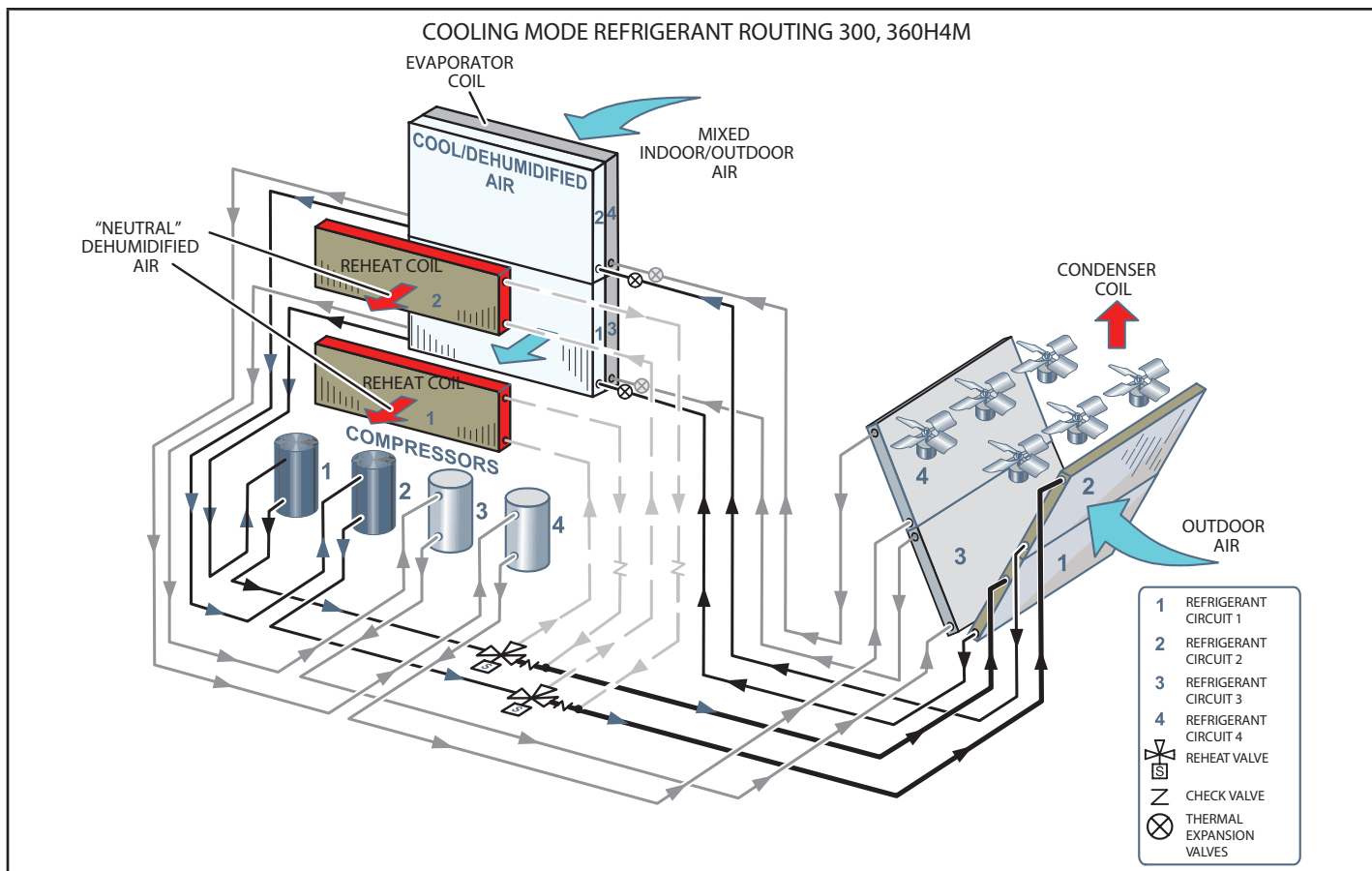

FIGURE 39



Check-Out

Test reheat operation using the following procedure.

- 1 - Make sure reheat is wired as shown in wiring section.
- 2 - Make sure unit is in local thermostat mode.
- 3 - Use the Unit Controller key pad to elect **SERVICE** → **TEST** → **DEHUMIDIFIER**

300, 360 - The blower, compressor 1, and compressor 2 (reheat) should be operating. L14 and L30 LEDs on the Unit Controller should also be ON, indicating the reheat valves are energized, REHEAT MODE will appear on the Unit Controller display.

- 4 - Press **BACK** on the Unit Controller display to stop the testing mode.

Default Reheat Operation

Reheat will operate as shown in TABLE 20 once three conditions are met.

- 1 - Blower must be operating.
- 2 - System must be in occupied mode.
- 3 - System must NOT be operating in heating mode.

IMPORTANT - Free cooling does not operate during reheat.

For other reheat control options, refer to the Unit Controller manual.

Additional Cooling Stages (3-Stage)

Units are shipped from the factory to provide two stages of cooling.

Three stages of cooling is available in zone sensor mode. Three stages of cooling is also available by installing a transfer relay and a three-stage thermostat. Refer to the Main Control Operation section in the Unit Controller manual when using the transfer relay.

Additional Cooling Stages (4-Stage)

Four stages of cooling is available in zone sensor mode on units with four compressors.

Compressors are not de-energized when unit operation changes from cooling to reheat or from reheat to cooling. Instead, L14 and L30 reheat valves are energized (reheat) or de-energized (cooling).

NOTE - Another thermostat staging option is available which allows both compressors to be energized during free cooling. See Unit Controller manual for details.

**TABLE 20
REHEAT OPERATION**

Two-Stage Thermostat - Default	
T'stat and Humidity Demands	Operation
	300, 360 (4-Compressors)
Reheat Only	Compressor 1 & 2 Reheat
Reheat & Y1	Compressor 1 & 2 Reheat Compressor 3 Cooling ¹
Reheat & Y1 & Y2	Compressor 1, 2, 3, & 4 Cooling ³
Three-Stage Thermostat (Transfer relay required)	
T'stat and Humidity Demands	Operation
	300, 360 (4-Compressors)
Reheat Only	Compressor 1 & 2 Reheat
Reheat & Y1	Compressor 1 & 2 Reheat Compressor 3 Cooling ¹
Reheat & Y1 & Y2	Compressor 1 & 2 Reheat Compressor 3 & 4 Cooling ³
Reheat & Y1 & Y2 & Y3	Compressor 1, 2, 3, & 4 Cooling ⁴
Four-Stage Zone Sensor Mode	
Cooling* and Humidity** Demands	Operation
	300, 360 (4-Compressors)
Reheat Only	Compressor 1 & 2 Reheat
Reheat & Y1	Compressor 1 & 2 Reheat Compressor 3 Cooling ¹
Reheat & Y1 & Y2	Compressor 1 & 2 Reheat Compressor 3 & 4 Cooling ²
Reheat & Y1 & Y2 & Y3	Compressor 1 Reheat, Compressor 2, 3, & 4 Cooling ³
Reheat & Y1 & Y2 & Y3 & Y4	Compressor 1, 2, 3, & 4 Cooling ⁵

*Cooling stage is initiated when zone temperature is higher than the cooling setpoint plus the appropriate stage differential.

**Reheat demand is initiated when relative humidity is higher than relative humidity setpoint.

¹If there is no reheat demand and outdoor air is suitable, free cooling will operate.

²If there is no reheat demand and outdoor air is suitable, free cooling and compressor 1 will operate.

³If there is no reheat demand and outdoor air is suitable, free cooling and compressor 1 and 2 will operate.

⁴If there is no reheat demand and outdoor air is suitable, free cooling and compressor 1, 2, and 3 will operate.

⁵If there is no reheat demand and outdoor air is suitable, free cooling and compressor 1, 2, 3, and 4 will operate.

The following conditions must be met before reheat will be energized:
(factory-default; see Unit Controller manual for other options)

- 1 - Blower must be operation.
- 2 - System must be in occupied mode.
- 3 - System must NOT be operating in heating mode.

Optional Economizer Settings

A-Control Settings

The economizer, when configured, controls:

- Damper position, which determines how much outdoor air is used to meet free cooling or indoor air quality requirements.
- Can be used to control optional power exhaust fans.

On a cooling demand, outdoor air is used for free cooling instead of first-stage compressor(s) when outdoor air is suitable.

To enable the economizer, if installed, go to **SETUP** → **INSTALL** and go through the wizard. When reaching **Configuration ID 1**, position **2** will need to be set to the applicable type of economizer. Valid types are as indicated below:

- **M** = Motorized Outdoor Air Damper Only
- **T** = Economizer - Temperature (NOTE - Used for both set point and offset temperature control).
- **G** = Economizer - Global
- **S** = Economizer - Single Enthalpy
- **D** = Economizer - Dual Enthalpy

The following options are available depending on economizer set above. These settings are available through the main menu at **SETUP** → **TEST & BALANCE** → **DAMP-ER**.

B-Damper Minimum Position Setting

Use the following menu path to modified the minimum damper positions for both high and low operations.

SETUP → **TEST & BALANCE** → **DAMP-ER** → **MIN DAMPER POSITION BLOWER ON HIGH = %**

SETUP → **TEST & BALANCE** → **DAMP-ER** → **MIN DAMPER POSITION BLOWER ON LOW = %**

C-Economizer Operation

NOTE - Use indicating lights on Unit Controller to determine thermostat demand.

See TABLE 25 for economizer operation with a standard two-stage thermostat.

TABLE 26 shows economizer operation with an energy management system which uses a global sensor.

Both tables show the occupied and unoccupied time period. The occupied time period is determined by the thermostat or energy management system.

TABLE 27 shows economizer operation in zone sensor mode.

D-IAQ Damper Operation

The Unit Controller has a 0-10VDC IAQ input for a standard 0-2000ppm CO2 sensor. The economizer starts opening at a CO2 level of 500 ppm (default) and reaches full open at a CO2 level of 1000ppm. Adjustments may be made to the indoor air quality parameters to alter operation or meet required specifications. Use the user interface to change Parameter 117 through 119. Go to **SETTINGS** → **RTU OPTIONS** → **EDIT PARAMETER**.

If the economizer is operating in the free cooling mode and the IAQ sensor demands more fresh air, the IAQ demand will override the free cooling demand to open the dampers further or to keep them open.

The IAQ function is not energized during the unoccupied or night time period.

TABLE 21
MENU INTERFACE (LEVEL 1 - SETTINGS) - M (MOTORIZED OUTDOOR AIR DAMPER ONLY)

Level 2	Level 3	Level 4	Level 5	Use the ADJUST and SET VALUES arrows to scroll up or down for selection of options.
RTU OPTION	DAMP-ER	MINI DAMPER POSITION BLOWER ON HIGH = X.X%		
		MINI DAMPER POSITION BLOWER ON LOW = X.X%		
		DEMAND CONTROL VENT DAMPER START OPEN = XXXX.X PPM		
		DEMAND CONTROL VENT DAMPER FULL OPEN = XXXX.X PPM		
		DEMAND CONTROL VENT DAMPER MAX OPENING = XXXX.X PPM		
		FRESH AIR HEATING ENABLE FAH = YES or NO	FRESH AIR HEATING FAH SETPOINT = XXF	
		FRESH AIR HEATING ENABLE FAH = YES or NO	FRESH AIR COOLING AFC SETPOINT = XXF	

TABLE 22
MENU INTERFACE (LEVEL 1 - SETTINGS) - T (TEMPERATURE ECONOMIZER)

Level 2	Level 3	Level 4	Level 5	Use the ADJUST and SET VALUES arrows to scroll up or down for selection of options.	
RTU OPTION	DAMPER	ECONOMIZER TEMP ECON TYPE = TEMPERATURE OFFSET OR TEMPERATURE SETPOINT			
		ECONOMIZER OAT SETPOINT = XX.X F			
		FREE COOLING SUPPLY AIR SETPOINT = XX F			
		MINI DAMPER POSITION BLOWER ON HIGH = X.X%			
		MINI DAMPER POSITION BLOWER ON LOW = X.X%			
		DEMAND CONTROL VENT DAMPER START OPEN = XXXX.X PPM			
		DEMAND CONTROL VENT DAMPER FULL OPEN = XXXX.X PPM			
		DEMAND CONTROL VENT DAMPER MAX OPENING = XXX.X%			
		FRESH AIR HEATING ENABLE FAH = YES or NO	FRESH AIR HEATING FAH SETPOINT = XXF		
		FRESH AIR HEATING ENABLE FAH = YES or NO	FRESH AIR COOLING AFC SETPOINT = XXF		

TABLE 23
MENU INTERFACE (LEVEL 1 - SETTINGS) - G (GLOBAL ECONOMIZER)

Level 2	Level 3	Level 4	Level 5	Use the ADJUST and SET VALUES arrows to scroll up or down for selection of options.	
RTU OPTION	DAMPER	FREE COOLING SUPPLY AIR SETPOINT = XX F			
		MINI DAMPER POSITION BLOWER ON HIGH = X.X%			
		MINI DAMPER POSITION BLOWER ON LOW = X.X%			
		DEMAND CONTROL VENT DAMPER START OPEN = XXXX.X PPM			
		DEMAND CONTROL VENT DAMPER FULL OPEN = XXXX.X PPM			
		DEMAND CONTROL VENT DAMPER MAX OPENING = XXXX.X PPM			
		FRESH AIR HEATING ENABLE FAH = YES or NO	FRESH AIR HEATING FAH SETPOINT = XXF		
		FRESH AIR HEATING ENABLE FAH = YES or NO	FRESH AIR COOLING AFC SETPOINT = XXF		

**TABLE 24
DEMAND CONTROL VENTILATION PARAMETERS**

Control Parameter			Control Value			Units	Description
No.	Screen Name	Parameter Short Description	Min.	Default	Max.		
117	DCV MAX DAMPER OPEN	Demand Control Ventilation Maximum Damper Open	0	100	100	%	Maximum allowed demand control ventilation damper open position.
118	DCV DAMP START OPEN	Demand Control Ventilation Dampe Start Open	0	700	2000	PPM	<ul style="list-style-type: none"> Damper "start open" CO₂ set point for Demand Control Ventilation. Level where fresh air damper begins to open.
119	DCV DAMP FULL OPEN	Demand Control Ventilation Maximum Damper Full Open Set Point	0	1200	2000	PPM	<ul style="list-style-type: none"> Damper "start open" CO₂ set point for Demand Control Ventilation. Level where fresh air damper is opened to maximum.
120	DCV HI TMP OV FL CL	Demand Control Ventilation Outdoor Air Control High Temperature Override Full Closed	-31.0	105.0	132.0	°F	High outdoor air temp. where fresh air damper is closed to minimum position.
121	DCV HI TEMP OV ST CL	Demand Control Ventilation Outdoor Air Control High Temperature Override Start Closing	-31.0	75.0	132.0	°F	High outdoor air temp. where fresh air damper begins to close.
122	DCV LO TEMP OV FL CL	Demand Control Ventilation Outdoor Air Control Low Temperature Override Full Closed	-31.0	10.0	132.0	°F	Low outdoor air temp. where fresh air damper is closed to minimum position.
123	DCV LO TMP OV ST CL	Demand Control Ventilation Outdoor Air Control Low Temperature Override Start Closing	-31.0	40.0	132.0	°F	Low outdoor air temp. where fresh air damper begins to close.
134	IAQ INPUT MODE	Indoor Air Quality Input Mode	0	1	6	Option	<p>IAQ input source and mode (0-3 operate only when blower is on).</p> <p>0 - Demand Control Ventilation System Indoor Air Quality. Either P298-3 or network indoor air quality.</p> <p>1 - Demand Control Ventilation System Indoor Air Quality. Either P298-3 or network Indoor Air Quality with no outdoor air temperature limits.</p> <p>2 - Outdoor Air Control Sensor A24 (A133_P194-6)(TB22-6)</p> <p>3 - Outdoor Air Control Sensor A24 (A133_P194-6)(TB22-6) with no outdoor air temperature limits.</p> <p>4 - Demand Control Ventilation System Indoor Air Quality. Either P298-3 or network Indoor Air Quality with blower on/auto operation.</p> <p>5 - Demand Control Ventilation System Indoor Air Quality. Either P298-3 or network Indoor Air Quality with blower on/auto operation with no outdoor air temperature limits.</p>



AA **BB** **CC** **DD**

01

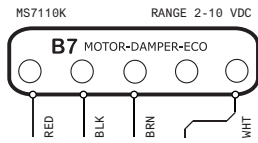

02

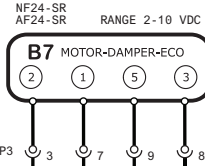

03

04

05

06

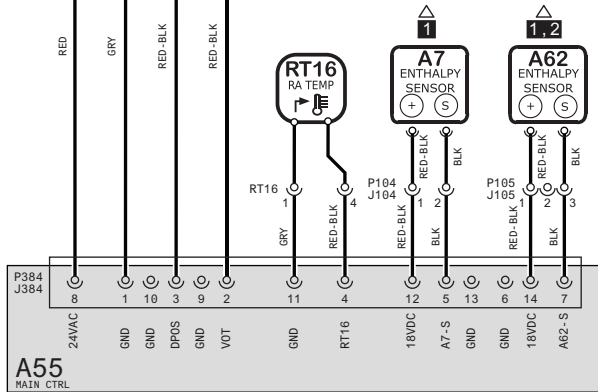

07

NOTES	
1	A7 AND A62 NOT USED FOR SENSIBLE TEMPERATURE CONTROL
2	FOR UNIT DIFFERENTIAL ENTHALPY CONTROL, ADD A62 RETURN AIR ENTHALPY SENSOR

08

KEY LIST		
LOCATION		COMPONENT DESCRIPTION
CC05	A7	SENSOR, SOLID STATE ENTHALPY
AA06	A55	CONTROL BOARD, MAIN
DD05	A62	SENSOR, ENTHALPY INDOOR
BB02	B7	MOTOR, DAMPER ECONOMIZER
CC05	RT16	SENSOR, RETURN AIR TEMP

09

10

Model: LC, LG, LH, LD, SC, SG Series Economizer & Motorized OAD
 Voltage: All Voltages
 Supersedes: N/A

© 2019

HTG SEC A	CLG SEC B	CLG SEC B3	ACCS SEC C	ACCS SEC D
-----------------	-----------------	------------------	------------------	------------------

WIRING DIAGRAM FLOW

Form No: **538072-01** Rev: 2

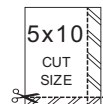

REV	EC NO.	DATE	BY	APVD	REVISION NOTE
---	CN-008594	10/15/2020	RV	MXR6	ORIGINATED AT PD&R CARROLLTON, TX
001	CN-010356B	03/24/2022	MXR6	JAL21	UPDATED APPLICABLE MODEL NUMBERS.
002	CN-012457P	03/06/2024	AXL	AAH	A) ADDED SC, SG TO MODELS

**TABLE 25
ECONOMIZER OPERATION - Standard Two-Stage Thermostat (Default Option)**

THERMOSTAT DEMAND	DAMPER POSITION UNOCC.	DAMPER POSITION OCCUPIED	MECHANICAL COOLING
OUTDOOR AIR IS NOT SUITABLE FOR FREE COOLING			
OFF	CLOSED	CLOSED	NO
G	CLOSED	MINIMUM	NO
Y1	CLOSED	MINIMUM	STAGE 1
Y2	CLOSED	MINIMUM	STAGES 1 AND 2
OUTDOOR AIR IS SUITABLE FOR FREE COOLING			
OFF	CLOSED	CLOSED	NO
G	CLOSED	MINIMUM	NO
Y1	MODULATING	MODULATING	NO
Y2	MODULATING	MODULATION (1)	STAGE 1

NOTE - modulating dampers adjust to control supply air (RT6) to 55°F (13°C). (1) the unit controller goes into a “cool down” or “warm-up” mode when the occupied time period starts. (2) Units with two-stage compressor operation will operate only stage 1 with a Y2 demand.

**TABLE 26
ECONOMIZER OPERATION WITH GLOBAL SENSING - Energy Management System (Default Option)**

THERMOSTAT DEMAND	DAMPER POSITION UNOCC.	DAMPER POSITION OCCUPIED	MECHANICAL COOLING
GLOBAL INPUT OFF			
OFF	CLOSED	CLOSED	NO
G	CLOSED	MINIMUM	NO
Y1	CLOSED	MINIMUM	STAGE 1
Y2	CLOSED	MINIMUM	STAGES 1 AND 2
GLOBAL INPUT ON			
OFF	MODULATING	MODULATING	NO
G	MODULATING	MODULATING	NO
Y1	MODULATING	MODULATING	STAGE 1
Y2	MODULATING	MODULATING (1)	STAGES 1 AND 2 (2)

NOTE - modulating dampers adjust to control supply air (RT6) to 55°F (13°C). (1) the unit controller goes into a “cool down” or “warm-up” mode when the occupied time period starts. (2) Units with two-stage compressor operation will operate only stage 1 with a Y2 demand.

**TABLE 27
ECONOMIZER OPERATION WITH GLOBAL SENSING - Zone Sensor Mode**

THERMOSTAT DEMAND	DAMPER POSITION UNOCC.	DAMPER POSITION OCCUPIED	MECHANICAL COOLING
OUTDOOR AIR IS NOT SUITABLE FOR FREE COOLING			
OFF	CLOSED	CLOSED	NO
G	CLOSED	MINIMUM	NO
Cooling Stage 1	CLOSED	MINIMUM	COMPRESSOR 1
Cooling Stage 2	CLOSED	MINIMUM	COMPRESSOR 1 & 2
Cooling Stage 3	CLOSED	MINIMUM	COMPRESSOR 1, 2, & 3
Cooling Stage 4	CLOSED	MINIMUM	COMPRESSOR 1, 2, 3, & 4
OUTDOOR AIR IS SUITABLE FOR FREE COOLING			
OFF	CLOSED	CLOSED	NO
G	CLOSED	MINIMUM	NO
Cooling Stage 1	MODLUATING	MODULATING	NO
Cooling Stage 2	FULL OPEN*	FULL OPEN*	COMPRESSOR 1
Cooling Stage 3	FULL OPEN*	FULL OPEN*	COMPRESSOR 1 & 2
Cooling Stage 4	FULL OPEN*	FULL OPEN*	COMPRESSOR 1, 2, & 3

*Damper will modulate to maintain 55°F (13°C) supply air when parameter 164 is changed to setting “0”.

NOTE - Modulating damper adjust to control supply air (RTG) to 55°F (13°C).

Optional Outdoor Air CFM Control

Outdoor Air CFM Control is a factory-installed option available on units equipped with a supply air variable frequency drive (VFD) and economizer.

The Unit Controller modulates outdoor air dampers to maintain a constant amount of outdoor air regardless of blower speed. This ensures minimum ventilation requirements are met at lower supply air speeds.

The Unit Controller uses a velocity sensor (A24) to modulate dampers. The sensor is located in the outdoor air stream. See FIGURE 41.

Set Damper Minimum Position

- 1 - Enable the Outdoor Air Control feature and set the velocity sensor range using the M3 Unit Controller **SETUP** → **INSTALL** menu. Navigate to Configuration ID 1. Set position **8** to:

H - Outdoor air control installed with A24 control set for low range (0 - 1968-ft/min).

NOTE - The configuration ID setting (H) must be paired with the "low" jumper position on the A24 control (see FIGURE 42). The jumper is factory-set at low range (0 - 1968-ft/min).

- 2 - Operate the blower in high speed and adjust the minimum damper position. Use **SETUP** → **TEST & BALANCE** → **DAMPER** → **MIN DAMPER POSITION** menu. Adjust minimum damper position and press **SAVE**. The Unit Controller will automatically save and display the velocity setpoint. Press **SAVE** again to confirm.

NOTE - The minimum damper position setting **MUST** be set lower than the OAC max damper position setting (50% default). To modify the max damper position setting, navigate to **SETTING** → **EDIT PARAMETERS** and select parameter 117 (DCV MAX DAMPER OPEN).

Additional outdoor air CFM control settings are available. See parameters 117 and 134 in the Unit Controller manual. Make adjustments through the **SETTINGS** → **EDIT** → **PARAMETERS** menu; select the required parameter.

- 3 - Replace A24 control cover.

NOTE - Refer to local codes or authorities having jurisdiction when determining design minimum outdoor air requirements.

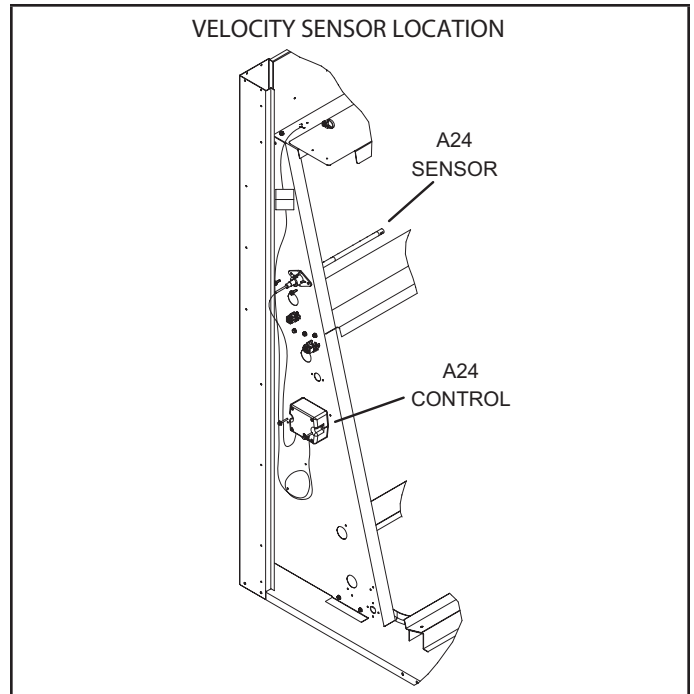

FIGURE 41

Velocity Sensor Settings

The A24 control is factory-set for 0-10-m/s (0-1968-ft/min).

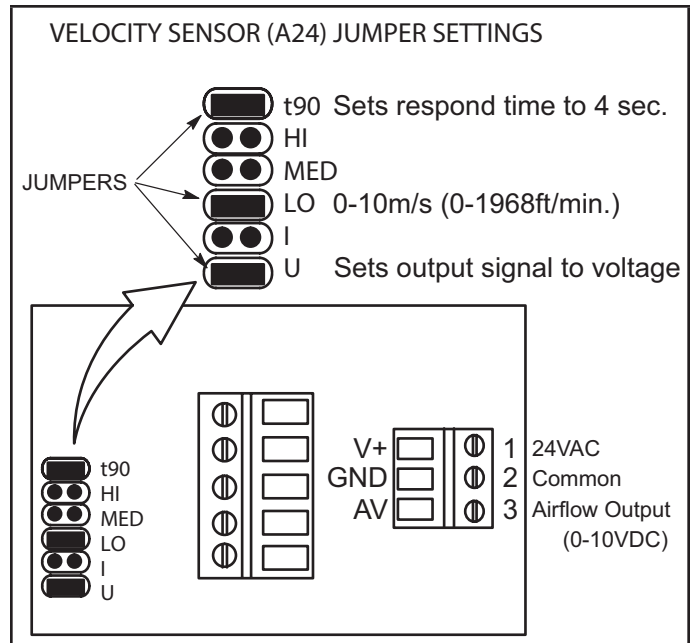

FIGURE 42

Preventative Maintenance / Repair

IMPORTANT MAINTENANCE / REPAIR SAFETY INSTRUCTIONS

Prior to beginning work on systems containing FLAMMABLE REFRIGERANTS, safety checks are necessary to ensure that the risk of ignition is minimized.

Work shall be undertaken under a controlled procedure to minimize the risk of a flammable gas or vapor being present while the work is being performed.

All maintenance staff and others working in the local area shall be instructed on the nature of work being carried out. Work in confined spaces shall be avoided.

The area shall be checked with an appropriate refrigerant detector prior to and during work, to ensure the technician is aware of potentially toxic or flammable atmospheres. Ensure that the leak detection equipment being used is suitable for use with all applicable refrigerants, i.e. non-sparking, adequately sealed or intrinsically safe.

If any hot work is to be conducted on the refrigerating equipment or any associated parts, appropriate fire extinguishing equipment shall be available to hand. Have a dry powder or CO2 fire extinguisher adjacent to the charging area.

No person carrying out work in relation to a REFRIGERATING SYSTEM which involves exposing any pipe work shall use any sources of ignition in such a manner that it may lead to the risk of fire or explosion. All possible ignition sources, including cigarette smoking, should be kept sufficiently far away from the site of installation, repairing, removing and disposal, during which refrigerant can possibly be released to the surrounding space. Prior to work taking place, the area around the equipment is to be surveyed to make sure that there are no flammable hazards or ignition risks. "No Smoking" signs shall be displayed.

Where electrical components are being changed, they shall be fit for the purpose and to the correct specification. At all times, the manufacturer's maintenance and service guidelines shall be followed. If in doubt, consult the manufacturer's technical department for assistance.

Repair and maintenance to electrical components shall include initial safety checks and component inspection procedures. If a fault exists that could compromise safety, then no electrical supply shall be connected to the circuit until it is satisfactorily dealt with. If the fault cannot be corrected immediately but it is necessary to continue operation, an adequate temporary solution shall be used. This shall be reported to the owner of the equipment so all parties are advised.

Initial safety checks shall include:

- that capacitors are discharged: this shall be done in a safe manner to avoid possibility of sparking
- that no live electrical components and wiring are exposed while charging, recovering or purging the system
- that there is continuity of earth bonding

The following checks shall be applied to installations using FLAMMABLE REFRIGERANTS:

- the actual REFRIGERANT CHARGE is in accordance with the room size within which the refrigerant containing parts are installed;
- the ventilation machinery and outlets are operating adequately and are not obstructed;
- if an indirect refrigerating circuit is being used, the secondary circuit shall be checked for the presence of refrigerant;
- marking to the equipment continues to be visible and legible. Markings and signs that are illegible shall be corrected;
- refrigerating pipe or components are installed in a position where they are unlikely to be exposed to any substance which may corrode refrigerant containing components, unless the components are constructed of materials which are inherently resistant to being corroded or are suitably protected against being so corroded.

During repairs to sealed electrical components, the components shall be replaced. Replacement parts shall be in accordance with the manufacturer's specifications.

During repairs to intrinsically safe components, the components must be replaced. Replace components only with parts specified by the manufacturer. Other parts may result in the ignition of refrigerant in the atmosphere from a leak.

The unit should be inspected once a year by a qualified service technician.

CAUTION

Label all wired prior to disconnection when servicing controls. Wiring errors can cause improper and dangerous operation. Verify proper operation after servicing.

A-Filters

Units are equipped with twelve 20 X 20 X 2" (508 X 508 X 51mm) filters. Filters should be checked monthly and replaced when necessary with filters of like kind and size. Take note of air flow direction marking on filter frame when reinstalling filters. See FIGURE 43.

NOTE - Filters must be U.L.C. certified or equivalent for use in Canada.

B-Lubrication

All motors are lubricated at the factory. No further lubrication is required.

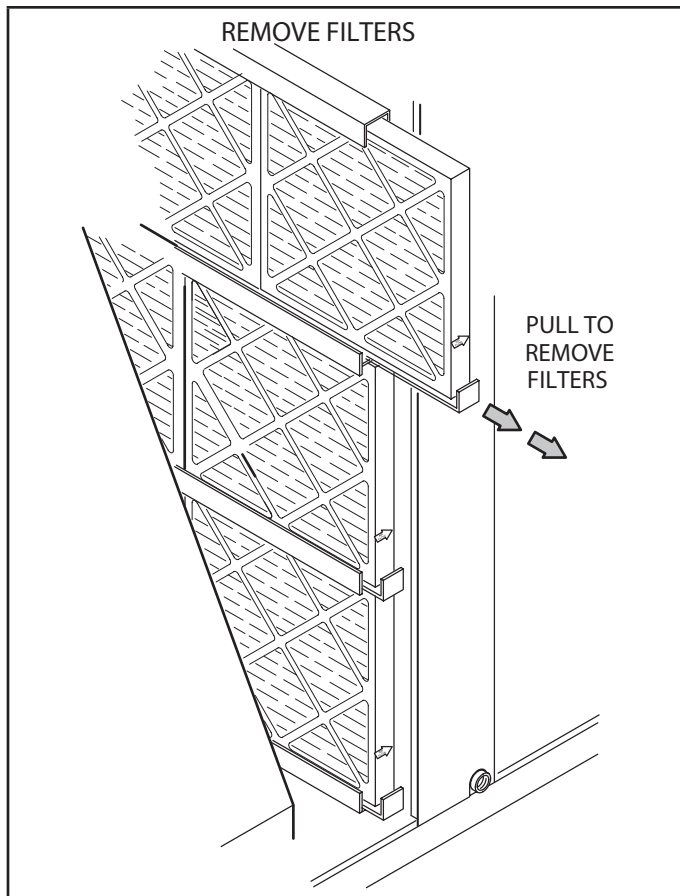

FIGURE 43

Blower shaft bearings are prelubricated. For extended bearing life, relubricate at least once every two years with a lithium base grease, such as Alvania 3 (Shell Oil), Chevron BRB2 (Standard Oil) or Regal AFB2 (Texas Oil). Use a hand grease gun for relubrication. Add only enough grease to purge through the bearings so that a bead of grease appears at the seal lip contacts.

C-Burners (Gas Units)

Periodically examine burner flames for proper appearance during the heating season. Before each heating season examine the burners for any deposits or blockage which may have occurred.

Clean burners as follows:

- 1 - Turn off both electrical power and gas supply to unit.
- 2 - Open burner compartment access panel.
- 3 - Remove screws securing burner assembly to burner support and remove assembly. See FIGURE 44. Clean as necessary.

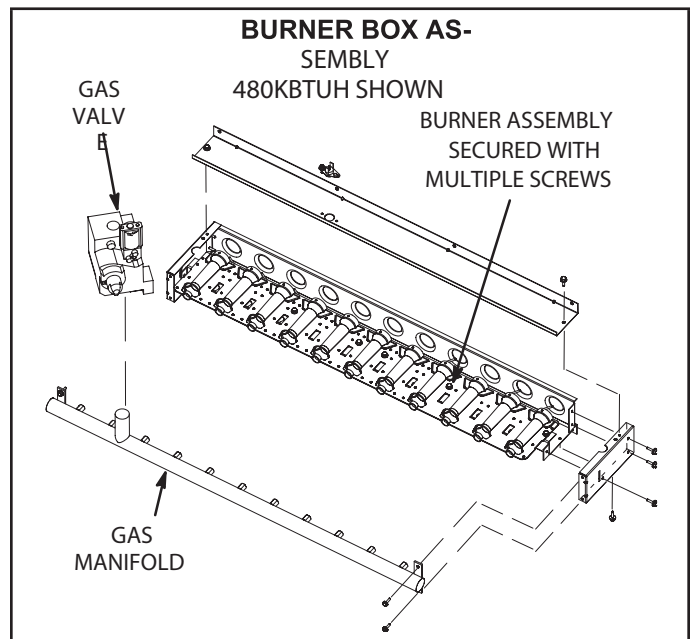

FIGURE 44

- 4 - Locate the ignitor under the left burners. Check ignitor spark gap with appropriately sized twist drills or feeler gauges. See FIGURE 45.
- 5 - Check the alignment of the ignitor and the sensor as shown in FIGURE 45 and TABLE 28.
- 6 - Replace burners and screws securing burner.

⚠ WARNING



Danger of explosion. Can cause injury or product or property damage. Do not use matches, candles, flame or other sources of ignition to check for leaks.

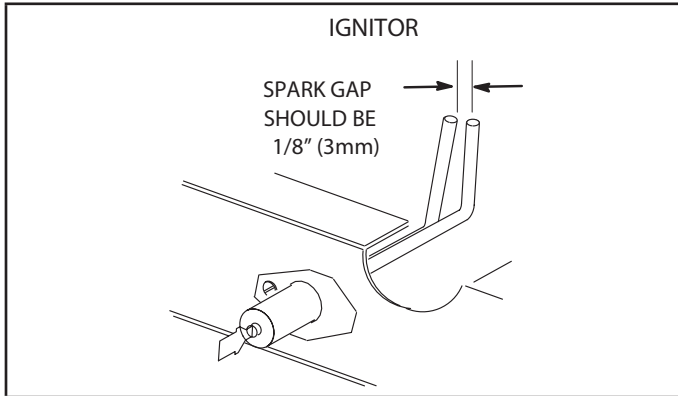

FIGURE 45

TABLE 28

Dimension	Unit Btuh Input	Length - in. (mm)	
		Ignitor	Sensor
A	260K	7-3/4 (197)	11 (279)
B	360K	5 (127)	5-1/2 (140)
C	480K	2-1/4 (57)	2-3/4 (70)

7 - Replace access panel.

8 - Restore electrical power and gas supply. Follow lighting instructions attached to unit and use inspection port in access panel to check flame.

D-Combustion Air Inducer (Gas Units)

A combustion air blower proving switch checks combustion air inducer operation before allowing power to the gas controller. Gas controller will not operate if inducer is obstructed.

Under normal operating conditions, the combustion air inducer wheel should be checked and cleaned prior to the heating season. However, it should be examined periodically during the heating season to establish an ideal cleaning schedule. With power supply disconnected, the condition of the inducer wheel can be determined by looking through the vent opening.

Clean combustion air inducer as follows:

- 1 - Shut off power supply and gas to unit.
- 2 - Disconnect pressure switch air tubing from combustion air inducer port.
- 3 - Remove and retain screws securing combustion air inducer to flue box. Remove and retain two screws from bracket supporting vent connector. See FIGURE 47.
- 4 - Clean inducer wheel blades with a small brush and wipe off any dust from housing. Clean accumulated dust from front of flue box cover.

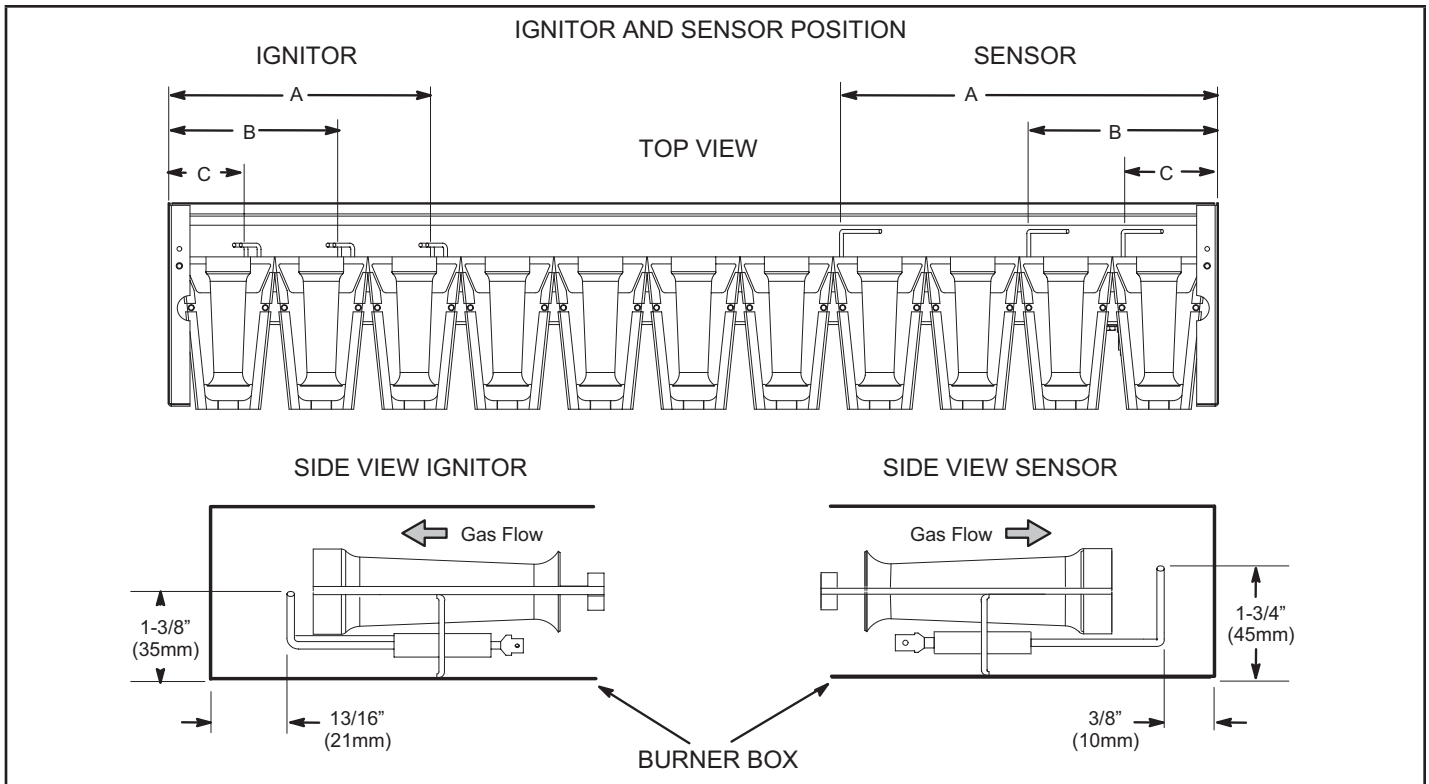

FIGURE 46

- 5 - Return combustion air inducer motor and vent connector to original location and secure with retained screws. It is recommended that the combustion air inducer gasket be replaced during reassembly.
- 6 - Clean combustion air inlet louvers on heat access panel using a small brush.

E-Flue Passageway and Flue Box (Gas Units)

- 1 - Remove combustion air inducer assembly as described in section D.
- 2 - Remove flue box cover. Clean with a wire brush as required.
- 3 - Clean tubes with a wire brush.
- 4 - Reassemble the unit. The flue box cover gasket and combustion air inducer gasket should also be replaced during reassembly.

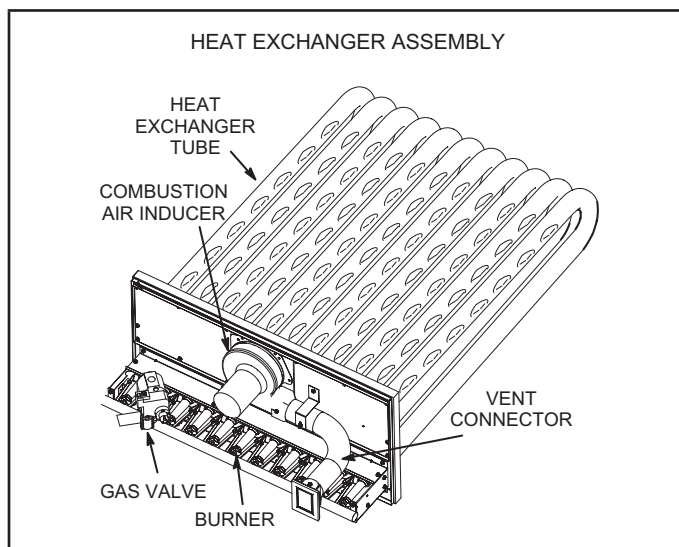

FIGURE 47

F-Evaporator Coil

Inspect and clean coil at beginning of each cooling season. Clean using mild detergent or commercial coil cleaner. Flush coil and condensate drain with water taking care not to get insulation, filters and return air ducts wet.

G-Supply Air Blower Wheel

Annually inspect supply air blower wheel for accumulated dirt or dust. Turn off power before attempting to remove access panel or to clean blower wheel.

H-Condenser Coil

Clean condenser coil annually with water and inspect monthly during the cooling season. Access panels are provided on front and back of condenser section.

Clean the all-aluminum coil by spraying the coil steadily and uniformly from top to bottom. Do not exceed 900 psi or a 45° angle; nozzle must be at least 12 inches from the coil face. Take care not to fracture the braze between the fins and refrigerant tubes. Reduce pressure and work cautiously to prevent damage.

M-Replacement Fuses

See the following tables for the proper replacement fuse sizes.

ELECTRIC HEAT REPLACEMENT FUSES				
	Electric Heat	Qty.	Rating	
			Amp	Volt
1	EHA240-7.5-1Y,2Y	3	50	250
2	EHA360-15-,1Y2Y	6	60	250
3	EHA360-22.5-1Y,2Y	3 EA.	25 & 50	250
4	EHA360-45-1Y,2Y	3/6	50 & 60	250
5	EHA240-7.5-1G,2G	3	25	600
6	EHB240-10-1G	3	35	600
7	EHB240-20-1G	6	15	600
8	EHB240-40-1G	6	35	600
9	EHA360-15-1G,2G	3	50	600
10	EHA360-22.5-1G,2G	3 EA.	15 & 25	600
11	EHA360-45-1G,2G	3 EA.	25 & 50	600
12	EHA240-7.5-1J,2J	3	20	600
13	EHA360-15-1J,2J	3	40	600
14	EHA360-22.5-1J,2J	3 EA.	10 & 20	600
15	EHA360-45-1J,2J	3 EA.	20 & 40	600

TABLE 29

LGT MODELS FUSE TABLE									
Unit Voltage				208/230V - 3 Ph		460V - 3Ph		575V - 3Ph	
Power Exhaust Option				W / P.E.	W / O P.E.	W / P.E.	W / O P.E.	W / P.E.	W / O P.E.
Diagram Key	Class	Model	Blower HP	Amps					
CB10 ³	-	LGT302	5	150	150	70	70	50	50
CB10 ³	-	LGT302	7.5	150	150	70	70	60	50
CB10 ³	-	LGT302	10	175	150	80	80	60	60
CB10 ³	-	LGT360	5	150	150	80	70	60	60
CB10 ³	-	LGT360	7.5	175	150	80	80	60	60
CB10 ³	-	LGT360	10	175	175	90	80	60	60
F61 ¹	J	LGT302	5	150	150	70	70	50	50
F61 ¹	J	LGT302	7.5	150	150	70	70	60	50
F61 ¹	J	LGT302	10	175	150	80	80	60	60
F61 ¹	J	LGT360	5	150	150	80	70	60	60
F61 ¹	J	LGT360	7.5	175	150	80	80	60	60
F61 ¹	J	LGT360	10	175	175	90	80	60	60
F10 ¹	CC	ALL	ALL	8					

² Fuses F10 and F61 are only used on units with SCCR installed.

³ Units using Circuit Breakers will use CB10 option.

TABLE 30

LCT MODELS FUSE TABLE																	
Electric Heat Size				0 KW						30 KW							
Unit Voltage				208/230V - 3 Ph		460V - 3 Ph		575V - 3 Ph		208V - 3 Ph		240V - 3 Ph		460V - 3 Ph		575V - 3 Ph	
Power Exhaust Option				W / P.E.	W / O P.E.	W / P.E.	W / O P.E.	W / P.E.	W / O P.E.	W / P.E.	W / O P.E.	W / P.E.	W / O P.E.	W / P.E.	W / O P.E.	W / P.E.	W / O P.E.
Diagram Key	Model	Class	Blower HP	Amps													
F4	LCT302	RK or K ¹	5	150	150	70	70	50	50	150	150	150	150	70	70	50	50
F4	LCT302	RK or K ¹	7.5	150	150	70	70	60	50	150	150	150	150	70	70	60	50
F4	LCT302	RK or K ¹	10	175	150	80	80	60	60	175	150	175	150	80	80	60	60
F4	LCT360	RK or K ¹	5	150	150	80	70	60	60	150	150	150	150	80	70	60	60
F4	LCT360	RK or K ¹	7.5	175	150	80	80	60	60	175	150	175	150	80	80	60	60
F4	LCT360	RK or K ¹	10	175	175	90	80	60	60	175	175	175	175	90	80	60	60
F10 ²	ALL	CC	ALL	8													
CB10 ³	LCT302	-	5	150	150	70	70	50	50	150	150	150	150	70	70	50	50
CB10 ³	LCT302	-	7.5	150	150	70	70	60	50	150	150	150	150	70	70	60	50
CB10 ³	LCT302	-	10	175	150	80	80	60	60	175	150	175	150	80	80	60	60
CB10 ³	LCT360	-	5	150	150	80	70	60	60	150	150	150	150	80	70	60	60
CB10 ³	LCT360	-	7.5	175	150	80	80	60	60	175	150	175	150	80	80	60	60
CB10 ³	LCT360	-	10	175	175	90	80	60	60	175	175	175	175	90	80	60	60
F61 ²	LCT302	J	5	-	-	-	-	-	-	150	150	150	150	70	70	50	50
F61 ²	LCT302	J	7.5	-	-	-	-	-	-	150	150	150	150	70	70	60	50
F61 ²	LCT302	J	10	-	-	-	-	-	-	175	150	175	150	80	80	60	60
F61 ²	LCT360	J	5	-	-	-	-	-	-	150	150	150	150	80	70	60	60
F61 ²	LCT360	J	7.5	-	-	-	-	-	-	175	150	175	150	80	80	60	60
F61 ²	LCT360	J	10	-	-	-	-	-	-	175	175	175	175	90	80	60	60

¹ When SCCR is installed, F4 fuse is Class J.

² Fuses F10 and F61 are only used on units with SCCR installed.

³ Units using Circuit Breakers will use CB10 option.

TABLE 31

LCT MODELS FUSE TABLE (CONTINUED)																			
Electric Heat Size				45 KW								60 KW							
Unit Voltage				208V - 3 Ph		240V - 3 Ph		460V - 3 Ph		575V - 3 Ph		208V - 3 Ph		240V - 3 Ph		460V - 3 Ph		575V - 3 Ph	
Power Exhaust Option				W / P.E.	W / O P.E.	W / P.E.	W / O P.E.	W / P.E.	W / O P.E.	W / P.E.	W / O P.E.	W / P.E.	W / O P.E.	W / P.E.	W / O P.E.	W / P.E.	W / O P.E.	W / P.E.	W / O P.E.
Diagram Key	Model	Class	Blower HP	Amps															
F4	LCT302	RK or K ¹	5	150	150	150	150	70	70	50	50	150	150	150	150	70	70	50	50
F4	LCT302	RK or K ¹	7.5	150	150	150	150	70	70	60	50	150	150	150	150	70	70	60	50
F4	LCT302	RK or K ¹	10	175	150	175	150	80	80	60	60	175	150	175	150	80	80	60	60
F4	LCT360	RK or K ¹	5	150	150	150	150	80	70	60	60	150	150	150	150	80	70	60	60
F4	LCT360	RK or K ¹	7.5	175	150	175	150	80	80	60	60	175	150	175	150	80	80	60	60
F4	LCT360	RK or K ¹	10	175	175	175	175	90	80	60	60	175	175	175	175	90	80	60	60
F10 ²	ALL	CC	ALL	8															
CB10 ³	LCT302	-	5	150	150	175	175	90	800	70	70	175	150	175	175	90	90	70	70
CB10 ³	LCT302	-	7.5	175	150	175	175	90	90	70	70	175	175	200	175	100	90	80	70
CB10 ³	LCT302	-	10	175	175	200	175	100	90	80	70	175	175	200	200	100	90	80	80
CB10 ³	LCT360	-	5	150	150	175	175	90	80	70	70	175	150	175	175	90	90	70	70
CB10 ³	LCT360	-	7.5	175	150	175	175	90	90	70	70	175	175	200	175	100	90	80	70
CB10 ³	LCT360	-	10	175	175	200	175	100	90	80	70	175	175	200	200	100	90	80	80
F61 ²	LCT302	J	5	150	150	175	175	90	800	70	70	175	150	175	175	90	90	70	70
F61 ²	LCT302	J	7.5	175	150	175	175	90	90	70	70	175	175	200	175	100	90	80	70
F61 ²	LCT302	J	10	175	175	200	175	100	90	80	70	175	175	200	200	100	90	80	80
F61 ²	LCT360	J	5	150	150	175	175	90	80	70	70	175	150	175	175	90	90	70	70
F61 ²	LCT360	J	7.5	175	150	175	175	90	90	70	70	175	175	200	175	100	90	80	70
F61 ²	LCT360	J	10	175	175	200	175	100	90	80	70	175	175	200	200	100	90	80	80

¹ When SCCR is installed, F4 fuse is Class J.
² Fuses F10 and F61 are only used on units with SCCR installed.
³ Units using Circuit Breakers will use CB10 option.

TABLE 32

LCT MODELS FUSE TABLE (CONTINUED)																			
Electric Heat Size				90 KW								120 KW							
Unit Voltage				208V - 3 Ph		240V - 3 Ph		460V - 3 Ph		575V - 3 Ph		208V - 3 Ph		240V - 3 Ph		460V - 3 Ph		575V - 3 Ph	
Power Exhaust Option				W / P.E.	W / O P.E.	W / P.E.	W / O P.E.	W / P.E.	W / O P.E.	W / P.E.	W / O P.E.	W / P.E.	W / O P.E.	W / P.E.	W / O P.E.	W / P.E.	W / O P.E.	W / P.E.	W / O P.E.
Diagram Key	Model	Class	Blower HP	Amps															
F4	LCT302	RK or K ¹	5	150	150	150	150	70	70	50	50	150	150	150	150	70	70	50	50
F4	LCT302	RK or K ¹	7.5	150	150	150	150	70	70	60	50	150	150	150	150	70	70	60	50
F4	LCT302	RK or K ¹	10	175	150	175	150	80	80	60	60	175	150	175	150	80	80	60	60
F4	LCT360	RK or K ¹	5	150	150	150	150	80	70	60	60	150	150	150	150	80	70	60	60
F4	LCT360	RK or K ¹	7.5	175	150	175	150	80	80	60	60	175	150	175	150	80	80	60	60
F4	LCT360	RK or K ¹	10	175	175	175	175	90	80	60	60	175	175	175	175	90	80	60	60
F10 ²	ALL	CC	ALL	8															
CB10 ³	LCT302	-	5	225	225	250	250	125	125	100	100	300	300	350	350	175	175	150	125
CB10 ³	LCT302	-	7.5	250	225	300	250	150	125	110	100	300	300	350	350	175	175	150	150
CB10 ³	LCT302	-	10	250	250	300	300	150	150	110	110	300	300	350	350	175	175	150	150
CB10 ³	LCT360	-	5	225	225	250	250	125	125	100	100	300	300	350	350	175	175	150	125
CB10 ³	LCT360	-	7.5	250	225	300	250	150	125	110	100	300	300	350	350	175	175	150	150
CB10 ³	LCT360	-	10	250	250	300	300	150	150	110	110	300	300	350	350	175	175	150	150
F61 ²	LCT302	J	5	225	225	250	250	125	125	100	100	300	300	350	350	175	175	150	125
F61 ²	LCT302	J	7.5	250	225	300	250	150	125	110	100	300	300	350	350	175	175	150	150
F61 ²	LCT302	J	10	250	250	300	300	150	150	110	110	300	300	350	350	175	175	150	150
F61 ²	LCT360	J	5	225	225	250	250	125	125	100	100	300	300	350	350	175	175	150	125
F61 ²	LCT360	J	7.5	250	225	300	250	150	125	110	100	300	300	350	350	175	175	150	150
F61 ²	LCT360	J	10	250	250	300	300	150	150	110	110	300	300	350	350	175	175	150	150

¹ When SCCR is installed, F4 fuse is Class J.
² Fuses F10 and F61 are only used on units with SCCR installed.
³ Units using Circuit Breakers will use CB10 option.

Decommissioning

Before carrying out this procedure, it is essential that the technician is completely familiar with the equipment and all its detail. It is recommended good practice that all refrigerants are recovered safely.

Prior to the task being carried out, an oil and refrigerant sample shall be taken in case analysis is required prior to re-use of recovered refrigerant. It is essential that electrical power is available before starting decommissioning.

- a) Become familiar with the equipment and its operation.
- b) Isolate system electrically.
- c) Before attempting the procedure, ensure that:
 - mechanical handling equipment is available, if required, for handling refrigerant cylinders;
 - all personal protective equipment is available and being used correctly;
 - the recovery process is supervised at all times by a competent person;
 - recovery equipment and cylinders conform to the appropriate standards.
- d) Pump down refrigerant system, if possible.
- e) If a vacuum is not possible, make a manifold so that refrigerant can be removed from various parts of the system.
- f) Make sure that cylinder is situated on the scales before recovery takes place.

g) Start the recovery machine and operate in accordance with instructions.

h) Do not overfill cylinders (no more than 80% volume liquid charge).

i) Do not exceed the maximum working pressure of the cylinder, even temporarily.

j) When the cylinders have been filled correctly and the process completed, make sure that the cylinders and the equipment are removed from site promptly and all isolation valves on the equipment are closed off.

k) Recovered refrigerant shall not be charged into another REFRIGERATING SYSTEM unless it has been cleaned and checked.

IMPORTANT

Equipment shall be labelled stating that it has been decommissioned and emptied of refrigerant. The label shall be signed and dated. Ensure that there are labels on the equipment that state the flammability of the refrigerant used.

START-UP REPORT

Job Name: _____
 Store No. _____ Start-Up Date: _____
 Address: _____
 City: _____ State: _____
 Start-Up Contractor: _____
 Technician: _____
 Model No.: _____
 Serial No.: _____
 RTU No.: _____ Catalog No.: _____

Inspections and Checks			
Damage?	Yes	No	R454B <input type="checkbox"/>
If yes, reported to: _____			
Verify factory and field-installed accessories.			
Check electrical connections. Tighten if necessary.			
Supply voltage: L1-L2 _____ L1-L3 _____ L2-L3 _____			
If unit contains a 208-230/240 volt transformer:			
Check primary transformer tap <input type="checkbox"/>			
Transformer secondary voltage: _____			

Cooling Checks												
Compressor Rotation <input type="checkbox"/> Ambient Temp. _____ Return Air Temp. _____ Supply Air Temp. _____												
	Compressor Amps			Compressor Volts			Pressures		Condenser Fan Amps			CC Heater Amps
	L1	L2	L3	L1-L2	L1-L3	L2-L3	Disch.	Suct.	L1	L2	L3	L1
1												
2												
3												
4												

Blower Checks			
Pulley/Belt Alignment <input type="checkbox"/>	Blower Rotation <input type="checkbox"/>		
Set Screws Tight <input type="checkbox"/>	Belt Tension <input type="checkbox"/>		
Nameplate Amps: _____		Volts: _____	
Motor	Amps	Volts	
	L1 _____	L1-L2 _____	
	L2 _____	L1-L3 _____	
	L3 _____	L2-L3 _____	

Heating Checks - Electric							
Return Air Temp.: _____ Supply Air Temp.: _____							
Limits Operate: <input type="checkbox"/>							
	Amps						
	L1	L2	L3		L1	L2	L3
1				10			
2				11			
3				12			
4				13			
5				14			
6				15			
7				16			
8				17			
9				18			

Heating Checks - Gas		
Fuel type: Nat. <input type="checkbox"/> LP <input type="checkbox"/> Inlet Pressure: _____ in. w.c.		
Return Air Temp.: _____ Supply Air Temp.: _____		
Altitude: _____ Primary Limits Operate: <input type="checkbox"/>		
CO ₂ %: _____		
Gas Valve	Manifold Pressure	
	Low Fire	High Fire
GV1		
GV2		

Accessory Checks	
Power Exhaust Amps	
1 _____	2 _____ None <input type="checkbox"/>
Economizer Operation	
Min. Pos. <input type="checkbox"/>	Motor travel full open/close <input type="checkbox"/>

Control Type